

Stony Brook University



OFFICIAL COPY

The official electronic file of this thesis or dissertation is maintained by the University Libraries on behalf of The Graduate School at Stony Brook University.

© All Rights Reserved by Author.

On (Non)Factivity, Clausal Complementation and the CP-Field

A Dissertation Presented

by

Carlos Francisco de Cuba

to

The Graduate School

in Partial Fulfillment of the

Requirements for the Degree of

Doctor of Philosophy

in

Linguistics

Stony Brook University

August 2007

Stony Brook University

The Graduate School

Carlos Francisco de Cuba

We, the dissertation committee for the above candidate for the

Doctor of Philosophy degree, Hereby recommend

acceptance of this dissertation

Daniel L. Finer - Advisor
Professor, Department of Linguistics

Richard K. Larson - Chairperson of Defense
Professor, Department of Linguistics

John F. Bailyn
Associate Professor, Department of Linguistics

Marcel den Dikken
Professor, Department of Linguistics
CUNY Graduate Center

This dissertation is accepted by the Graduate School

Lawrence Martin
Dean of the Graduate School

Abstract of the Dissertation

On (Non)Factivity, Clausal Complementation and the CP-Field

by

Carlos Francisco de Cuba

Doctor of Philosophy

in

Linguistics

Stony Brook University

2007

This dissertation examines the syntactic and semantic behavior of sentential complement clauses under *factive* vs. *non-factive* verbs. These classes of verbs, while superficially similar, behave very differently both in the syntactic structures they allow and in the semantic interpretation of their complements. Kiparsky & Kiparsky 1971 provides the classic analysis, where factive verbs like *regret* are said to be associated with more complex syntactic structure than non-factive verbs like *believe*.

The main claim I make is that the classic analysis has it wrong - essentially backwards. I propose instead that it is actually *non-factives* that have a syntactic projection that *factives* lack. I provide cross-linguistic syntactic evidence for a more articulated non-factive structure, showing numerous cases where more complex syntactic structure is associated with non-factives, and not factives. I also show that the extra projection opens an escape hatch that allows for the freer *wh*-extraction pattern found in non-factive constructions.

I argue further that the extra syntactic projection contains a semantic operator that is responsible for non-factive interpretation. In the absence of this projection, a default factive interpretation results. This is a relatively recent semantic view of factivity, as in the past it has been widely assumed that factives were the special case in need of explanation. The view may be new, but it is well supported. In addition, I show that traditional ‘factivity’ classification is actually the wrong one to use to divide the verb classes. I argue that verbs should be classed as to whether they take ‘familiar’ or ‘novel’ complements, along the lines of Hegarty 1992. This semantic classification matches the syntactic data much better than a factive/non-factive distinction.

I exploit the extra structure and operator to provide an account for long-distance Negative Polarity Item licensing, which is available only under what are traditionally called non-factives. Finally, I show that in addition to covering the new data I present, my analysis covers the same empirical ground as Kiparsky and Kiparsky’s original proposal.

Table of Contents

Acknowledgements

vi

Chapter 1. Introduction

1. Factive vs. non-factive asymmetries.....	1
1.1. <i>Kiparsky & Kiparsky: The Classical Analysis</i>	4
1.2. <i>A new proposal</i>	4
1.3. <i>Non-factives as special, factives as the default</i>	5
2. Organization of the Thesis.....	9

Chapter 2. Embedded Verb-Second in MSc and cP

1. Introduction.....	13
2. The Proposal.....	15
3. Limited Embedded V2 in Swedish.....	18
3.1. <i>The Standard Cases: Matrix V2 and Factive Verbs (No EV2)</i>	19
3.2. <i>Non-factive Verbs (With or without EV2)</i>	21
3.3. <i>Positional and Phonological Optionality of the Complementizer</i>	24
3.4. <i>Negative Verbs, Negated Non-factive Verbs and Irrealis Verbs</i>	28
3.5. <i>Summary</i>	30
4. Hungarian.....	30
4.1. <i>Hungarian ‘Azt’</i>	30
4.2. <i>Summary</i>	32
5. What Verbs License EV2?.....	32
5.1. <i>Factivity and Assertion</i>	33
5.2. <i>Stance Verbs and Familiar Complements</i>	37
6. Icelandic and German.....	43
7. Summary.....	47

Appendix: Occupants of cP.....	49
--------------------------------	----

Chapter 3. Factive FCP Islands

1. Introduction.....	53
2. Subject Auxiliary Inversion and The Adjunction Prohibition.....	55
3. Adjunction and Inversion – McCloskey's Connection.....	58
4. FCP Islands and the Adjunction Prohibition.....	64
5. Adjunct Movement Restrictions in Serbian.....	67
6. Previous Analyses of Factive Islands.....	75
6.1. <i>Rizzi 1990, Cinque 1990, Melvold 1986</i>	75
6.2. <i>Nichols 2001</i>	77
7. Summary.....	84

Chapter 4. Long-distance NPI Licensing

1. Introduction.....	85
1.1. <i>The Proposal</i>	86
2. Laka's Negative Complementizer Analysis.....	87

3. Motivation for the Extra Structure and Operator.....	89
4. Optional Extra Structure.....	93
4.1. <i>Basque</i>	94
4.2. <i>English</i>	95
4.3. <i>Hungarian</i>	95
4.4. <i>NPI Licensing in Optional Cases</i>	98
5. Factive Cases in Basque.....	99
6. Tense and Long-distance NPI Licensing.....	102
6.1. <i>Uribe-Echevarria 1994</i>	102
6.2. <i>Uribe-Echevarria's First Argument Against a Neg-Comp Analysis</i>	104
7. Summary.....	107
Chapter 5. More on Selection: Other CP Clauses and Clauses Other than CP	
1. Introduction.....	109
2. ECM, Raising verbs and <i>tP</i>	111
3. Control.....	113
4. Small Clauses.....	114
4.1. <i>Uribe-Echevarria's Second Argument Against a Neg C Analysis</i>	117
5. More Selectional Differences Between FCPs and NCPs.....	121
5.1. <i>Nominal and non-nominal selection</i>	121
5.2. <i>Predicates with selectional options</i>	124
6. Attitude Nominals.....	125
7. Summary.....	128
References	130

Acknowledgements

There are many people who helped me along the way to finally finishing this dissertation. Hopefully I'll remember to mention everyone, but given the final deadline of my graduate career is today, and the fact that for one last time I've left something to the last minute, the possibility exists that I may omit someone. If so, please feel free to pencil in your name with appropriate commentary, and accept my apologies.

I start with my advisor, Dan Finer, who has tolerated my erratic progress, and always managed to get me back on track. Our Friday afternoon meetings over the years have been a source of great enjoyment to me, and I learned a great deal along the way. I couldn't imagine a better advisor for me. My committee members were also extremely influential in my graduate career. Richard Larson has been a great support to me, and throughout the years has regularly dropped relevant papers on my desk that have been important to the final product here. His tough criticism along the way has been a great help, and is much appreciated. John Bailyn has also been a great support to me, encouraging me to believe in myself and my ideas. He's also a great passing midfielder, and an excellent tour guide for Eastern Europe. I look forward to sharing a glass of 7-0 rakija soon. Last but certainly not least, Marcel den Dikken has been extremely generous with his time. He could easily be mistaken for a Stony Brook faculty member with all the support he has given to students here over the years. His ability to read and comment extensively on drafts is legendary, both for the speed in which he does it and for the depth and quality of the comments. No 'eel in a bucket of snot' is safe from his grasp, though I tried my best.

I would also like to thank the rest of the faculty of the Linguistics Department at Stony Brook for all their help. It is always easier to work in a place where there is a pleasant, friendly atmosphere to go along with the hard work, and I'm glad I was able to study in such a place. Many thanks also to the Turner Fellowship for providing financial and social support, without which graduate life would have been much more difficult, if not impossible.

I feel fortunate that I was able to meet and make friends with so many people in my time at Stony Brook, and I owe these people a debt of gratitude for helping to make life more enjoyable. Sandra Brennan had been my guardian angel since entering the

program, always making my life easier despite my best efforts to screw things up. Jason Brenier and Margo Dellicarpini kept me going in the early days when I sometimes felt like throwing in the towel. Barbara Ürögdi helped get many of the ideas in this dissertation off the ground, between spilled beers at the Velvet Lounge. Marianne Borroff, Susana Huidobro, Jon MacDonald and Lanko Marušič also contributed greatly to my knowledge of linguistics, life, and libations, not necessarily in that order. Yukiko Asano and Tomoko Kawamura kept me going on many late nights, somehow making Roth quad food seem edible. OK, I now realize that if I continue to write sentences for everyone I will miss the deadline - so thanks to Andrei Antonenko, Michele Tedesco, Jiwon Hwang, Xu Zheng, Riquin Miao, Hiroko Yamakido, Diane Abraham, Tanja Scott, Yiya Chen, Edith Aldrige, Yunju Suh, Miran Kim, Jackson Achinya, Jon Robinson, Julie Weisenberg, Yu-an Lu, Mark Lindsay, Hisako Takahashi, Hijo Kang, Hyun-ju Kim, Jisung Sun, Svitlana Antonyuk, Roksolana Mykhaylyk, Irina Tarabac, Anne Miller, Mark Volpe, Jang-il Kim, Chih-hsiang Shu, Young-ran An, Michael Helten, Rok Žaucer, Hedde Zeijlstra, Erika Troseth, Alison Gabriele, Tom Leu, Lisa Levinson, Oana Ciucivara, Eytan Zweig and Aldrige Football Club for many good times. Thanks also to Tanja Milićev, Nataša Milićević, Dragana Šurkalović, Svetozar Milićević, Ivana Mitrović, Radmila Šević and Boban Arsenijević for more life, linguistics, libations...

I owe a great debt of gratitude to my family for love and support (and patience) on the road to the dissertation. My parents, Myrna and Pedro de Cuba, have provided financial and emotional support throughout my life and education – it is a great feeling knowing I've made them proud. My sister Natalia has also always been a great support, especially in entertaining my family during my often prolonged stays at Stony Brook while writing this dissertation.

Finally, to my wife Annika, all the thanks in the world for your patience and love. Without you, none of this would be possible. I am truly a lucky man. And to my daughter Sofia, thanks for being so damn cute. Now we can finally go to the zoo.

Chapter 1: Introduction

1. Factive vs. non-factive asymmetries

In this dissertation I examine the syntactic and semantic behavior of sentential complement clauses under what have traditionally been called *factive* and *non-factive* predicates in the literature. In the classic paper, “Fact”, Kiparsky & Kiparsky (1971) (K&K henceforth) examine the syntax-semantics interface in the English complement system. They note that there are two classes of predicates, those that presuppose the truth of their sentential complements (factives) and those that do not (non-factives).

- (1) **Factives:** regret, resent, hate, comprehend, forget, grasp, make clear, like...
- (2) **Non-factives:** believe, claim, say, assert, is likely, is possible, conjecture...

Factives and non-factives differ in their semantic properties. In factive (3a), the truth of the sentential complement is presupposed, while in non-factive (3b) it is not. This remains the case if the matrix clause is negated, as in (4).

- (3) (a) I **regret** [that it is raining]
(b) I **believe** [that it is raining]
- (4) (a) I **don't regret** [that it is raining]
(b) I **don't believe** [that it is raining]

In other words, (3b) and (4b) can be true statements regardless of whether or not it is actually raining, while in (3a) and (4a) *that it is raining* must be true in order for the whole sentence to be true.

K&K also note that there are several syntactic differences between the verb classes, some of which are illustrated in (5) through (10).

- (5) Only factive predicates can have as their objects the noun *fact* with a *that*-clause:
- (a) I want to make clear the fact that I don't intend to participate.
 - (b) *I assert the fact that I don't intend to participate.
- (6) Only factive predicates can have as their objects the pronoun *it* with a *that*-clause:
- (a) Bill resents it that people are always comparing him to Mozart.
 - (b) *Bill claims it that people are always comparing him to Mozart.
- (7) Gerunds can be objects of factive predicates, but not freely of non-factive predicates:
- (a) I regret having agreed to the proposal.
 - (b) *I believe having agreed to the proposal.
- (8) Only non-factive predicates allow ECM constructions:
- (a) *I resent Mary to have been the one who did it.
 - (b) I believe Mary to have been the one who did it.
- (9) Factive complements can appear in subject position non-factive complements cannot:
- (a) [That there are porcupines in our basement] makes sense to me
 - (b) It makes sense to me [that there are porcupines in our basement]
 - (c) *[That there are porcupines in our basement] seems to me
 - (d) It seems to me [that there are porcupines in our basement]
- (10) Factive complements cannot be substituted with the pro-form *so*, non-factive complements can:
- (a) *John regretted that Bill had done it, and Mary regretted so too.
 - (b) John supposed that Bill had done it, and Mary supposed so too.

Several other asymmetries have been noted in the literature, in addition to those discussed by K&K. Factive complements do not allow embedded root phenomena (Emonds 1969; Hooper & Thompson 1973; Andersson 1975; Heycock 2000/2006), non-factives do, as in (11) and (12).

- (11) Factive complements do not allow Negative Adverb Preposing, non-factive complements do:
- (a) Prices never before have been so high
 - (b) Never before have prices been so high
 - (c) *Lou Dobbs resents that never before have prices been so high
 - (d) Lou Dobbs says that never before have prices been so high
- (12) Factive complements do not allow embedded verb second in Swedish, non-factive complements do:
- (a) Rickard ångrade att han inte var hemma
Rickard regretted that he not was home
 - (b) *Rickard ångrade att han var inte hemma
Rickard regretted that he was not home
“Rickard regretted that he was not home.”
 - (c) Rickard sa att han inte var hemma
Rickard said that he not was home
 - (d) Rickard sa att han var inte hemma
Rickard said that he was not home
“Rickard said that he was not home.”

There is also a difference in non-local Negative Polarity Item (NPI) licensing between factives and non-factives (13), and in adjunct extraction (14)..

- (13) Factive complements do not allow long-distance NPI licensing, non-factive complements do:
- (a) *I don't regret [that Jim *slept a wink* last night]
 - (b) I don't believe [that Jim *slept a wink* last night]
- (14) Factive complements are islands for adjunct extraction, non-factive complements are not:
- (a) *How do you **regret** that you behaved *t* ?
 - (b) How do you **think** that you behaved *t* ?

The semantic and syntactic differences between factives and non-factives in the examples above are at the core of this dissertation. I propose a novel analysis of these facts that

goes directly against the traditional K&K idea that there is extra structure associated with factive complements.

1.1. *Kiparsky & Kiparsky: The Classical Analysis*

In order to account for the asymmetries in (3) through (10), K&K hypothesize that the semantic difference is reflected in the syntactic deep structure, as in (15).

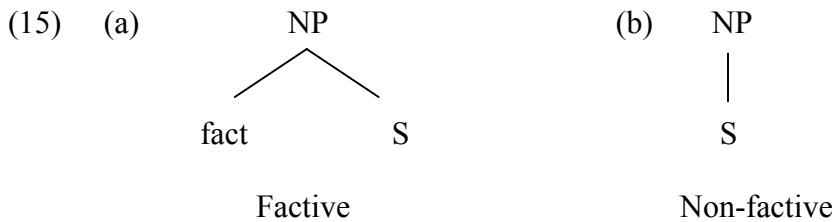

Factive complements contain the head noun *fact*, and non-factive complements do not. Semantic presupposition in factives (3a), (4a), is derived by the presence of the *fact*. The lack of *fact* in non-factives (3b), (4b), explains the lack of presupposition in these cases. Syntactically, the presence or absence of *fact* is exploited to account for the asymmetries in (5) through (10). K&K analyzed these differences using *fact* and a series of transformations (in the transformational framework being used at the time) to derive the different behavior of factives and non-factives.

The K&K solution, proposing extra syntactic structure, in the complements to factive predicates, has been the generally accepted solution in the literature since the 70's, and has been appealed to for over 35 years in countless analyses involving factive/non-factive asymmetries. While I agree with the K&K view that there is an inescapable link between syntax and semantics in factive and non-factive constructions, I explore the possibility that they had things backwards: that it in non-factive constructions that are associated with a more articulated syntactic structure than factives.

1.2. *A new proposal*

Updating the K&K structures in (15) to more recent versions of the theory gives us the basic structures in (16). Factive verbs select the NP (or DP) containing the head *fact*, and *fact* selects CP, as in (16a), while non-factives select CP directly (16b).

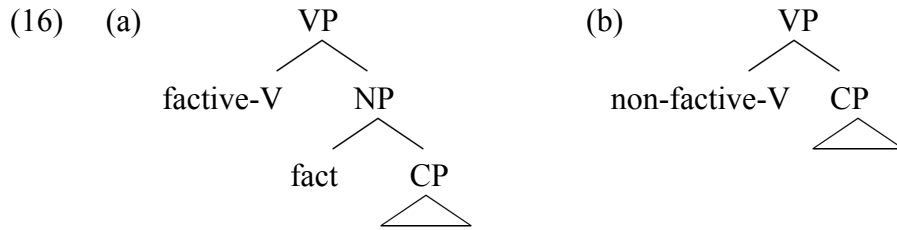

The core idea of this thesis is that the structures in (15) and (16) are incorrect. The main proposal is that the correct structures are instead the ones in (17). Factives directly select CP (17a), while non-factives select an intermediate projection headed by a semantic operator, which in turn selects CP (17b).

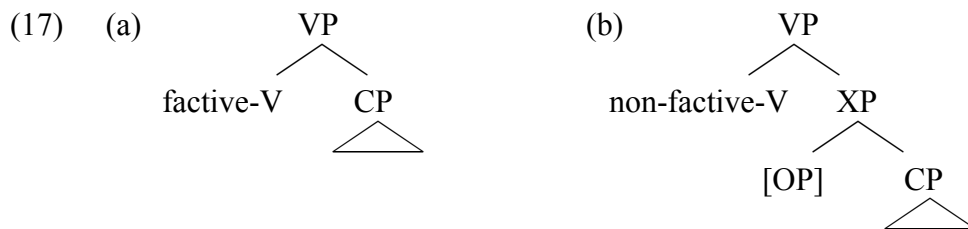

The proposal is that the classical analysis has things essentially backwards. It is non-factives that select a more complex complement, not factives. It is a relatively simple idea with many consequences to be discussed in detail throughout this work. It results from a recent view of the semantics of factivity, where a switch in the viewpoint of which class of verbs is the ‘special’ class has brought about a switch in where an extra syntactic projection is hypothesized to appear.

1.3. *Non-factives as special, factives as the default*

In K&K’s view of the semantics of factivity, factives are considered to be special, in need of some explanation for the presupposed status of their complements (3a), (4a). For them, presupposition comes from the head noun *fact* in (15a) and (16a). The view to be presented in this work, as mentioned, is opposite from the classical story. I argue that the presupposed status of factive complements is nothing special at all, but instead the default interpretation that factive main clauses also receive. Nichols 2001 articulates this relatively recent view of the semantics of factivity.

“The proposition in a factive complement clause...the complement of an attitude predicate like ‘regret’...is evaluated using a world set that includes the actual world. Accordingly, factive subordinate clauses simply make use of the default evaluation context...Factive complement propositions and factive main clause propositions therefore make use of the same (default) basic evaluation context. Consequently we have missed an important generalization if we consider factive complements somehow special...In contrast, the proposition in a non-factive complement clause is not evaluated in the default context; some interpretive element has been added by the selecting attitude predicate...that changes the composition of the evaluation set of worlds. Subordinate non-factive propositions therefore have an evaluation context that is special with respect to the conversational common ground. If factive evaluation contexts are not in need of special explanation, i.e. if their semantic properties are not special, then we might hypothesize that neither are the syntactic properties of factive complementation special...On the other hand, if the semantic (evaluation) contexts of non-factive clauses are special, then we might hypothesize that the syntactic properties of these non-factive clauses are special as well.”
(Nichols 2001:126)

In other words, the classical analysis is based on a mistaken assumption, that something extra is needed in the semantics to account for presupposition in factive complements. Taking the Nichols view, the semantic motivation for the head noun *fact* disappears, and is instead replaced by a need to somehow account for the special status of non-factives (3b), (4b).¹ The semantic motivation for an extra syntactic projection thus shifts from factive complements to non-factive complements. Along these lines, Nichols proposes that a semantic operator is needed in order to account for the special interpretation of non-factives. I follow Nichols in arguing for an operator, and additionally propose that the operator heads the syntactic projection XP in non-factive complement constructions (17b).

Haegeman (2006) shares the view that non-factive complements are structurally more complex than factive complements. For her, there is a CP-layer for speaker deixis, a functional layer that anchors a proposition to a speaker. This layer is absent in factive complements and present in non-factive complements. She argues against the need for an

¹ K&K also give syntactic motivations for the head noun *fact*; I return to these below.

operator in factive cases, contra Zubizarreta 2001. She shares a similar view of presupposition with Nichols: factive complements receive a default interpretation.

“Rather than containing an additional layer of structure hosting the assertion operator, complements of factive verbs can be argued to lack speaker deixis and hence to be structurally impoverished. In contrast with Zubizarreta’s analysis I propose that clauses introduced by ‘that’ and embedded under factive predicates be considered as reduced finite structures, characterized by the lack of speaker deixis (and TopP and FocP, the projections which are, by hypothesis licensed by speaker deixis.)... ‘Presupposition’ would thus not result from an extra operation on the proposition but rather from the lack of it: presupposed complements are those propositions that do not encode anchoring to a speaker. The ‘factive’ interpretation of such clauses could be seen as a default reading: their content, not being asserted, or related to the speaker, is, as it were, ‘taken for granted.’” (Haegeman 2006:1665)

More support for the special status of non-factives comes from work on acquisition. de Villiers 1998 shows that children under the age of four consistently answer with “reality” to questions with mental state or communication verbs. They have difficulty with questions like *What did she say she bought?* in a case where someone says she bought something other than she really bought. They consistently answer with what she really bought, as opposed to what she *said* she bought.² de Villiers concludes that these children have not yet acquired a feature in CP that allows for the representation of “false” propositions.

“The claim is that children have an ‘underarticulated’ CP that lacks some crucial feature, namely, whatever it is that allows the representation of ‘falsity’ for the embedded proposition...that only complements of mental and communication verbs can be ‘false’ propositions (vis a vis the ‘real world’, i.e. our point of view) and not upset the truth of the entire sentence. There must be some feature in CP to distinguish these cases from adjuncts, matrix clauses etc. whose truth must be judged independently with respect to ‘the real world’. Interestingly, such a feature is usually proposed to distinguish factive complements, but it is the non-factive complements of mental and communicative verbs that have the more distinctive characteristic. I am proposing some feature

² de Villiers (1998:126) notes that children can understand negation and deny falsehoods by around age 2 (Bloom 1970), so it is not a matter of the children being unable to handle statements of non-reality.

subcategorized for a particular verb that says that the proposition in its complement can be false...this feature is hypothesized to be set to one value in the CP of mental and communicative verbs, and to a different value in the matrix CP, the CP of factive verbs, or in the CP of relative clauses attached to head nouns, which are obligatorily true if the sentence is true.”
(de Villiers 1998:131)

It is increasingly clear that the evidence points to the special semantic status of non-factives as opposed to factives. It seems natural then to propose that the extra semantic machinery (Nichols’ operator, Haegeman’s speaker deixis, de Villiers feature) is represented in the syntax, as in (17b). The logic is the same as K&K, but with a change in the semantic view of factivity comes a change in the view of the syntax. Where for K&K the special semantic property, and thus the extra syntactic structure was with the factives, I argue throughout this work that the special semantic property of non-factivity is represented in extra syntactic structure. McCloskey 2005 draws similar conclusions, proposing that embedded questions and declarative complements with ‘assertoric force’ (both interpreted as non-factive) select a double CP structure, while ‘resolutive predicates’ (factives) select as single CP. He proposes:

“...the idea that a certain class of verbs (the ‘weak assertives’ of Hooper and Thompson (1973), the ‘bridge verbs’ of Erteschik-Shir (1973) and much of the literature on embedded Verb Second phenomena) take, as one option, double CP-complements with assertoric force”
(McCloskey 2005:39)

Haegeman (2006) finds more support in the literature from Grewendorf 2002, which cites Benincá and Poletto 2004 referring to the following idea:

“...that embedded clauses vary as to which portions of the CP-layer may be projected, and that this has to do with the selectional properties of the matrix verb...it may be a property of non-bridge verbs that their complement does not project the whole CP-layer while bridge verbs select a complete CP-layer with all the projections of the left periphery available.”
(Grewendorf 2002:53)

With each of the authors quoted above, the idea of extra structure has been put forward on semantic grounds. Their proposals are distinct, and not necessarily compatible with each other, but they are all exploring analyses opposite to the traditional Kiparskian view of extra structure in factive cases. This dissertation continues along these lines, arguing that the structures in (17) provide the best way to account for all of the factive vs. non-factive asymmetries listed in (3) through (14).

2. Organization of the Thesis

Chapter 2 focuses on the embedded verb second (EV2) phenomenon in Mainland Scandinavian. EV2, as in (12d) is an example of Embedded Root Phenomena, similar to the English negative adverb preposing case in (11b). EV2 and negative adverb preposing have been widely analyzed as involving movement to the CP-field, with the finite verb moving to C and some XP moving to SpecCP. In both (11d) and (12d), this movement occurs in the presence of an overt complementizer, another CP-field element, leading to the widely accepted analysis of CP-recursion. It is crucial to note that EV2 and negative adverb preposing are only possible in non-factive complements, suggesting that CP-recursion is not available under factives, ruling out (11c) and (12c). This is a case where more complex structure is clearly associated with a non-factive complement, and unavailable with a factive complement. I take this as evidence for the superiority of the structures in (17) over the ‘classical’ structures in (16).

The question of the categorial status of XP in (17) is answered in Chapter 2, with XP replaced by the functional category *cP*. *cP* is headed by a semantic operator that removes the speaker from responsibility for the truth-content of the embedded clause. I propose that *cP* inherits properties of the CP it selects, meaning the complementizer can merge into *c* instead of C, leaving CP open for EV2 movement, or negative adverb preposing. Additionally, *cP* inherits the phasal properties of CP, serving as a phase ‘extender’. With the main proposal in place, EV2 in mainland Scandinavian is fully analyzed, including discussions of the effects of negation and irrealis elements, and the optionality of complementizers in certain positions.

The last half of chapter 2 discusses the question of what verb classes license EV2, meaning which verbs can select for the more articulated structure in (17b). Reviewing the literature, it becomes clear that ‘factivity’ turns out to be the wrong notion in separating out the verbs that allow EV2 and the verbs that don’t allow EV2. Instead, the notion of ‘familiar’ vs. ‘novel’ complements, in the sense of Hegarty 1992, which follows the work of Cattell 1978, is adopted. The factive vs. non-factive distinction is replaced by ‘Familiar Complement-taking Predicates’ (FCPs) vs. ‘Novel Complement-taking Predicates’ (NCPs).

Chapter 3 presents an analysis of factive islands, the factive vs. nonfactive asymmetry in (14). Adjunct extraction is prohibited from factive complements (14a), but allowed from non-factive predicates (14b). As Cattell 1978 shows, the factive vs. non-factive distinction is not the crucial one for adjunct extraction, rather a notion of acceptance in the conversational background. The familiar complements of Hegarty 1992 ban adjunct extraction, while his novel complements allow it. An important discovery by Hegarty is that the class of verbs that allow EV2 in Mainland Scandinavian matches the class of verbs that allow adjunct extraction in English. In my terms, this means that both EV2 and adjunct extraction are possible from NCPs, which have the structure in (17b), while neither EV2 nor adjunct extraction are possible from FCPs, which have the structure in (17a). The main claim of the chapter is that it is the extra structure in (17b) facilitates adjunct extraction. This is in stark contrast to a K&K-style analysis, in which extraction is blocked out of factive complements by an extra syntactic projection.

McCloskey 2005, following Chomsky 1986, proposes the ‘Adjunction Prohibition’, which states that adjunction to a lexically selected complement is prohibited. I exploit this prohibition to account for the availability of adjunct extraction from non-factive complements. I claim that adjunct movement proceeds by adjunction to CP, as opposed to argument movement, which proceeds through SpecCP. Only in NCPs, which have the structure in (17b), is the CP not lexically selected by the verb, meaning only in (17b) in CP adjunction allowed, not in FCPs (17a). In this way, the extra projection in (17b) facilitates movement that would otherwise be blocked, allowing adjuncts to escape from NCP complements. The analysis is extended to account for

factive islands and adjunct/argument ordering restrictions in long-distance multiple *wh*-movement in Serbian.

Chapter 4 examines the factive vs. non-factive asymmetry in long-distance negative polarity item (NPI) licensing in (13). Long-distance NPI licensing is unavailable in factive complements (13a), but available in non-factive complements (13b). As in previous chapters, the factive vs. non-factive distinction is replaced with the FCP vs. NCP distinction, and again, the structures in (17) are exploited to explain the asymmetry. An obvious difference in the structures in (17) is the presence or absence of the semantic operator. The presence of the operator is used to remove the speaker from responsibility for the truth-content of the embedded clause. It is notable that the class of verbs that allow long-distance NPI licensing, NCPs, are also the class that take the structure that contains the operator (17b). I propose that a negative feature in *cP* mediates the licensing between matrix negation and the embedded NPI, meaning that the licensing in (13b) is not really long-distance at all.

This analysis is reminiscent of the proposal in Laka 1990, where a negative complementizer mediates long-distance NPI licensing. However, there are important differences in my analysis, the most crucial of which is that the negative feature is separate from the complementizer. This move eliminates the main objections of Uribe-Echevarria 1994 to Laka's negative complementizer analysis.

This chapter also introduces the idea that the extra structure proposed in (17b) is optional with some verbs. In my analysis, this means that these verbs are subcategorized to take either the structure in (17a) or (17b). However, the semantics of the construction will differ depending on whether or not the extra structure is present. If (17a) is selected, a familiar complement reading will result, and if (17b) is selected a novel complement reading will result. In addition, long-distance NPI licensing is unavailable if the verb selects (17a), as there is no operator to mediate between matrix negation and the embedded NPI. If the verb selects the structure in (17b), long-distance NPI licensing is possible.

Chapter 5 examines more cases of selectional differences between FCPs and NCPs, and looks at clauses smaller than CP that receive novel interpretations. To this point all previous novel complements were CP-level, and the novel interpretation was

claimed to come from the operator in *cP*. However, ECM verbs, raising verbs and small clause constructions are all widely analyzed as taking complements that are smaller than CP. The question that is raised then is where does the novel interpretation of these complements come from if there is no CP for *cP* to select? The answer proposed is that *cP* is but one example of a more general functional projection, headed by the operator, which can select different functional complements. Just as the operator phrase inherits properties from the CP it selects, it can also select TP for example and inherit properties from TP, giving us *tP*. I argue that *tP* is what is selected by ECM and raising verbs. In the same way, the operator phrase can select small clauses, giving us a kind of *scP*. The novel interpretation of these complements is thus explained: they are all headed by the operator phrase, and therefore are given a novel interpretation due to the presence of the operator.

The asymmetries noted by K&K in (5) through (10) are explained through selection. FCPs select nominal complements like NP/DP and CP, while NCPs select non-nominal complements like *cP*, *tP* and *scP*. Only FCPs can have as their objects the noun *fact* with a *that*-clause (5), or the pronoun *it* with a *that*-clause (6), because *the fact* is a nominal, which FCPs select and NCPs do not. Only NCPs allow ECM constructions (7) because NCPs can select a non-nominal like *tP*, while FCPs cannot. FCP complements can appear in subject position because nominal CP is compatible with subject position, while non-nominal *cP* selected by NCPs is not. FCP complements cannot be substituted with the pro-form *so*, as *so* is not a nominal pro-form, while non-nominal *cP* can be replaced by *so*.

Finally, I discuss attitude nominals like *belief*, *claim*, *realization* and *fact*. I propose that the structural difference at the VP level in (17) is mirrored at the DP level, with Novel Complement-taking Nominals (NCNs) like *belief*, and *claim* selecting *cP*, and Familiar Complement-taking Nominals (FCNs) like *realization* and *fact* selecting CP. Again, the operator is involved for novel interpretations. The fact that all extraction is blocked from both FCN and NCN complements is shown to result from the presence of DP, a phase, as opposed to VP.

Chapter 2: Embedded Verb-Second in MSc and cP

1. Introduction

It has been widely noted that many languages show an asymmetry in word order in root vs. embedded contexts. Certain constructions that occur in main clauses are not possible in embedded clauses. One such asymmetry is the verb-second (V2) effect in many Germanic languages. Den Besten 1983 provides the classical analysis of the V2 effect: translated into current terms, the finite verb moves to C and a topic fronts to Spec-CP. V2 is then blocked in subordinate contexts because of the presence of a complementizer in the embedded C. The classical analysis accounts for much of the Germanic data, but the pattern of limited embedded V2 in Swedish, exemplified in (1b), presents a problem.³

- (1) (a) Rickard sa att han inte var hemma [Swe]
Rickard said that he not was home
(b) Rickard sa att han var inte hemma
Rickard said that he was not home
“Rickard said that he was not home.”
- (2) (a) Rickard ångrade att han inte var hemma
Rickard regretted that he not was home
(b) *Rickard ångrade att han var inte hemma
Rickard regretted that he was not home
“Rickard regretted that he was not home.”

The (a) examples above show the standard word order for Swedish embedded complement clauses, where the verb *var* ‘was’ is below sentential negation, indicating that V2 movement of the verb from V-to-I-to-C has not taken place. The complementizer *att* ‘that’ is in the head of C, as in (3).⁴

³ For more examples and discussion of EV2 in Germanic, see Heycock 2000/2006, Holmberg & Platzack 1995, Vikner 1995, Iatradou & Kroch 1992, Platzack 1986, Holmberg 1983, Holmberg 1986 and Andersson 1975, among others.

⁴ For arguments against V-to-I movement in Swedish without V-to-I-to-C, see Holmberg & Platzack 1995.

- (3) [CP [C att] [IP han inte var hemma]]
that he not was home

Example (2b) shows that embedded verb-second (EV2) is not generally permitted, while (1b) is an example of limited embedded V2, the restriction being that it is only possible under matrix ‘bridge verbs’. The grammaticality of (1b) presents a problem for the classical analysis, because it predicts that the V2 effect should only be possible in the absence of a complementizer in C. In fact, an EV2 sentence without the complementizer is ungrammatical in Swedish.

The focus of this chapter is to account for the cluster of facts surrounding EV2 in Swedish, using a derivational style analysis in the spirit of Chomsky 2000, 2001. I propose that there is extra syntactic structure (*cP*) selected in the sentential complements of bridge verbs, which allows for EV2 movement in the presence of an overt complementizer in (2b). This extra structure is not available under non-bridge verbs, so (1b) is ruled out in the standard manner. What bridge verbs have in common is that they are all non-factive, and this semantic notion will be crucial in motivating the presence of the extra structure. Factive verbs, which are not bridge verbs, are not associated with the extra structure. My hope is to improve upon the CP-recursion analysis, which has been widely argued for (Vikner 1995, Holmberg & Platzack 1995, Watanabe 1992, Iatridou & Kroch 1992, Heycock 2000/2006, and others).

In addition to accounting for Swedish EV2 syntactic facts, I also argue that a semantic operator [OP] heads the proposed *cP* structure. This operator is responsible, roughly speaking, for “removing the speaker of an utterance from responsibility for the truth content of CP embedded below it.”

The chapter is organized as follows. In section 2, I present my proposal that there is an extra syntactic projection (*cP*) selected by non-factive verbs that is not selected by factives, which directly select CP. This projection is headed by a semantic operator [OP] that affects the evaluation of truth in the embedded CP. In section 3, I implement the proposal to account for limited EV2 in Swedish. I also present an account for complementizer optionality. In section 4, morphological and semantic evidence for the proposed projection is presented from Hungarian. The data points to the conclusion that

extra structure is associated with non-factive readings, as opposed to factive (contra Kiparsky & Kiparsky 1971 and others). Section 5 investigates the classification of verbs that allow embedded root phenomena like EV2, concluding that the factive/non-factive distinction is not the correct one. In the appendix, I provide discussion and speculations on the semantic content of *cP*.

2. The Proposal

To account for the syntactic difference between factive verb and non-factive verb sentential complement clause constructions, I propose that there is extra structure between *V* and *CP* in non-factive sentential complement constructions. This projection, call it *cP*, is headed by a semantic operator [OP].⁵

A non-factive verb selects for *cP* as opposed to a standard *CP*. *c* then selects for *CP*. Factive verbs do not select for *cP*, and therefore can never license the recursive-type *CP* construction⁶. The *cP/CP* construction is strictly limited by selectional properties, as *C* cannot select for *CP* or *cP*, and *c* cannot select for *cP*. Thus the recursive-type construction is limited to non-factive verb complement clauses. The structures are given below, (4) for factive verbs and (5) for non-factive verbs.

⁵ I will continue to refer to the function of the operator in informal terms, as “removing the speaker from responsibility for the truth of the embedded clause”. This is an oversimplification of the matter taken for expository ease, and more importantly because there is not a clear consensus in the literature as to what the exact semantic contribution of such an operator would be. For discussion of the possible contributions of the operator, see the appendix.

⁶ Of course this is not really a recursive structure, as *cP* and *CP* are different categories. I mention recursion as it has been widely used in analyzing EV2 (see references below). All of the previous analyses had difficulty in limiting the recursion, which is not a problem for the present analysis. In addition, straight *CP*-recursion should be ruled out if we assume that a head can not select a projection of its own type (In the spirit of van Riemsdijk 1998, Kayne 1982 and Stowell 1981). In Chapter 5 I claim that *cP* is a non-nominal-type phrase, while *CP* is a nominal-type phrase, and that this difference affects where each type of phrase can appear in the syntax. This difference also allows *cP* to select *CP*.

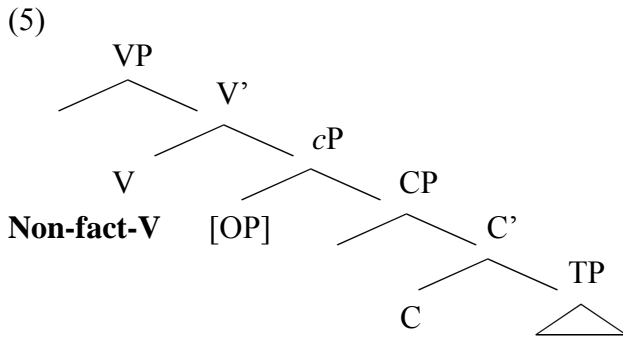
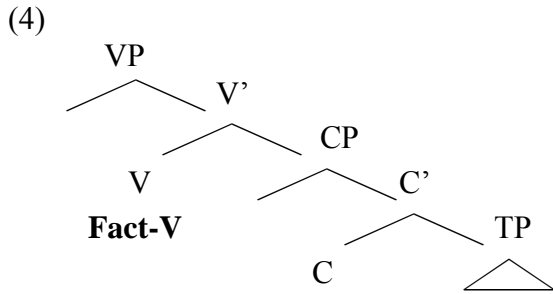

Swedish EV2 facts provide syntactic evidence that an extra position exists in the CP field. In (1b) we saw the presence of the overt complementizer *att* ‘that’ in conjunction with EV2. The classical analysis of V2 is of verb movement to C and topic movement to Spec-CP. Since complementizers presumably occur in C, it is natural to assume another layer of CP structure for (1b). Under the present proposal, the complementizer *att* in (4) is in the head of CP, blocking V2 movement. In (5), *att* is in the head of *cP*, and classical V2 movement takes place below *att* in CP. Various versions of the CP-recursion analysis of EV2 have been proposed, including Vikner 1995, Holmberg & Platzack 1995, Iatridou & Kroch 1992, Watanabe 1992 and Hegarty 1992. Differing from previous accounts, I claim that the extra structure is not actually a second CP, but the functional projection *cP*, selected by non-factive verbs, which in turn selects a CP. This extra level in the CP-field is selected by the verb, not licensed by the semantic content of the lower CP as in other accounts. The semantic interpretation of the CP is the same in (4) and (5), but the speaker is removed from responsibility for the truth content of a CP embedded under *cP*. Looking at data from English applied to (4) and (5), we see that the CPs in both sentences in (6)

are interpreted semantically in the same way, but the *cP* affects the truth-conditions of the non-factive verb complement.⁷

- (6) (a) John forgot [_{CP} that he went to the store]. (*he went to the store* = true)
(b) John thinks [_{cP} [OP] [_{CP} that he went to the store]]. (*he went to the store* may or may not be true)

The presence of *cP* is what changes the interpretation of the CP from factive to non-factive. In (6a), the evaluation of the truth of the entire sentence depends on the truth of the embedded clause. In (6b), the sentence can be true whether or not the embedded sentence clause is true. I locate this semantic difference in a semantic operator [OP] situated in the head of *cP*. The operator functions to remove the speaker from responsibility for the truth content of the embedded clause. Many semantic theories share the need to add extra structure in order to get the correct truth conditions for sentences with non-factive sentential complements.⁸ My proposal fits this need easily by providing an extra syntactic position that houses the [OP] that provides the semantic interpretation of non-factivity to a complement clause.

The [OP] contained in *cP* can affect movement possibilities. Inherently negative matrix verbs, irrealis matrix verbs and matrix negation with non-factive verbs all block EV2 in Swedish. In my proposal, what stops movement in these cases is the negative and/or irrealis licensing of the [OP] in *c*, making the [OP] into a negative [N-OP] or an irrealis [I-OP]. The negative or irrealis status of the operator blocks a merge that would have otherwise allowed for EV2. My analysis has similarities to earlier proposals, but differs from them all in significant respects.

At this point I should make clear that the ‘little *c*’ notation I am using represents a different type of animal than the ‘little *v*’ discussed in various papers by Chomsky.⁹ Chomsky originally introduced ‘little *v*’ as the supplier of an external theta-role, and later

⁷ EV2 is not available in restricted or non-restricted relative clauses in Swedish, in spite of the fact that it has been argued that RRCs are presupposed while NRRCs aren’t. However, the present analysis gives the correct prediction (no EV2 in relative clauses), as I argue that EV2 is a result of verb selection. I have nothing further to say about the semantic differences between RRCs and NRRCs.

⁸ Lambda operators, quotational theories, world theories etc. For a summary, see Larson & Segal 1995.

⁹ Thanks to Marcel den Dikken (p.c.) for helpful comments on this point.

generalized ‘little v ’ to all lexical verbs, including those that do not assign an external theta-role. He did so with an appeal to the Distributed Morphology idea that roots are acategorial and that their categorial status is determined by the ‘little x ’ that merges with the projection of the root. On the ‘generalized v ’ approach of Chomsky’s recent work, v must be merged with VP in order for VP to be well-formed.

The class of ‘little x ’ projections in the present proposal are clearly different from Chomsky’s ‘little v ’, as ‘little c ’ attaches to a functional projection (CP), as opposed to an acategorial lexical root.¹⁰ In addition, the ‘little x ’ class I am proposing does not assign an external theta-role. Finally, there is no well-formedness effect with ‘little c ’, as I am clearly proposing that CP can be independently well-formed as a maximal projection, as in factive complements (see (4)). Since there is no overlap in distribution (Chomsky’s ‘little x ’ projections attach to lexical projections, my ‘little x ’ projections attach to functional projections), it is not surprising that they have different properties, just as in general lexical items differ from functional items. However, both classes share the property of introducing something to the derivation. In the case of v , an external theta-role can be introduced, as well as categorial status. In the case of c , an operator providing non-factivity is introduced. More details on this operator are provided below in Section 6.

3. Limited Embedded V2 in Swedish

In this section I apply the proposal in section 2 to data from Swedish. The distribution of V2 in Swedish is roughly as follows:

- A. EV2 is prohibited under factive verbs.
- B. EV2 is optional under non-factive verbs.¹¹
- C. EV2 is prohibited under negated factives verbs, inherently negative verbs, and irrealis verbs.

¹⁰ I generalize the ‘little x ’ notation in Chapter 5 to tP and rP , in addition to cP in Chapter 5. These three categories are variations of the same phrase for me, and all differ from the role of vP discussed by Chomsky.

¹¹ Actually, bridge verbs are a subset of the non-factives. I will not discuss manner of speaking verbs, which require a different analysis from the one proposed here

The *cP* analysis is implemented to cover the facts in A-C. Additionally, I examine the optionality of the complementizer *att*, and propose an explanation for its distribution. Complementizers are only optional under non-factive verbs.

I make the following assumptions about movement and selection. Feature checking drives syntactic movement. There is an [+EPP] feature and a finite feature [+Fin] in CP in Swedish.¹² The [+EPP] feature is checked by XP movement to the specifier, and the [+Fin] is checked by head movement of a finite verb to C. In embedded clauses, the complementizer checks both the [+Fin] and [+EPP] features, so no XP movement to Spec-CP is needed. Factive verbs select CP, while non-factive verbs select *cP*.¹³

3.1. *The Standard Cases: Matrix V2 and Factive Verbs (No EV2)*

In (7) we see cases in Swedish where no *cP* is generated. (7a) is a standard matrix V2 construction with the finite verb *var* ‘was’ moving from V-to-T-to-C, and the subject *Dan* moving locally from Spec-VP to Spec-TP to Spec-CP. The movement of the verb is needed to check the Finite feature [+Fin] in C.¹⁴ *Dan* moves to Spec-TP, checking Nominative case [+Nom] features, then up to Spec-CP to check the [+EPP] feature.¹⁵ The phrase that moves to Spec-CP does not need to be the subject, as other XPs (objects, adverbials, negation, non-finite verbs) can also move and check [+EPP]. However, subject Spec-*vP* to Spec-TP movement is obligatory for case.

¹² For discussion of non-finite complement clauses and the factive/non-factive distinction, see Chapter 5.

¹³ For arguments that verb second movement is movement to IP in subject initial clauses, and that CP movement only occurs in inversion cases (driven by operators in CP, and possibly focus), see Zwart 1991 (and subsequent works), who follows Travis 1984.

¹⁴ This analysis is based on Holmberg & Platzack 1995.

¹⁵ For me, the [+EPP] is checked by a lexical item that bears syntactic features and is able to participate in a checking relationship. Note that while the verb checks [+Fin] in CP, it does not check [+EPP]. The fact that verbs don’t check [+EPP] is evidenced by obligatory subjects in TP in Swedish embedded clauses.

- (7) (a) Dan var inte hemma. [Swe]
Dan was not home
 “Dan wasn’t home”

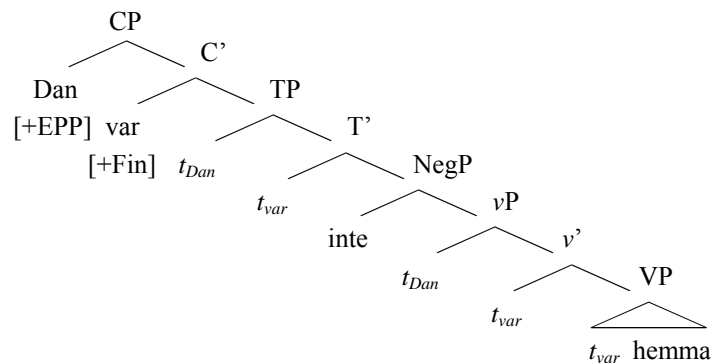

- (b) Rickard ångrade att Dan inte var hemma
Rickard regretted that Dan not was home
 “Rickard regretted that Dan wasn’t home”

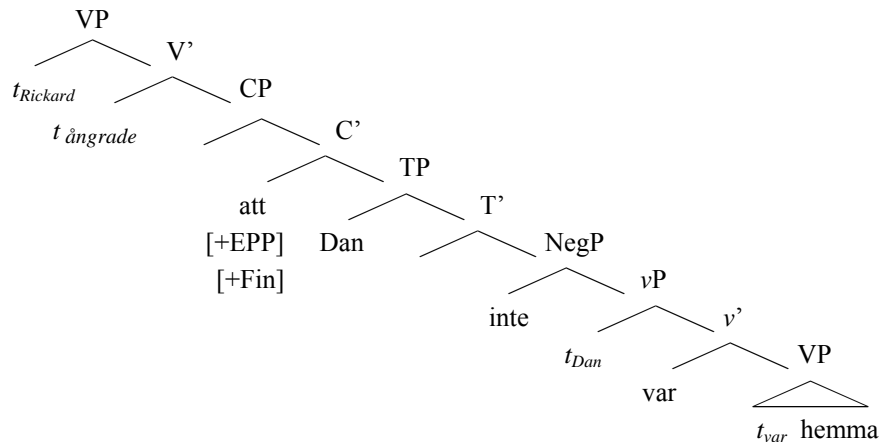

The same clause is shown embedded under a factive verb in (7b).¹⁶ *Dan* moves up to Spec-TP for case, but the verb *var* remains in VP.¹⁷ This is evidenced by the position of sentential negation *inte* above the verb.¹⁸ The [+Fin] and [+EPP] features in C are

¹⁶ For arguments against V-to-T movement in embedded clauses in Mainland Scandinavian, see Holmberg & Platzack 1995.

¹⁷ For reasons of space, the matrix clause above VP has been omitted. The matrix subject *Rickard* actually merges in Spec-vP, as is currently widely assumed. This convention is used for the remainder of the paper.

¹⁸ The placement of sentential negation and adverbs is constant in Swedish, directly above VP. I will not address the question of negation being above or adjoined to VP, as it is not the focus of this chapter.

checked by the overt complementizer *att*. This explains the ungrammaticality of topicalization over the complementizer, as illustrated in (8).

- (8) *Rickard ångrade [CP Dan_i [C att] [TP *t*_i [NegP *inte*] [vP *t*_i var hemma]]]
Rickard regretted Dan that not was home
 “Rickard regretted that Dan wasn’t home”

Semantically, the truth-values are straightforward. In order for (7a) to be true, *Dan was not home* has to be true. For (7b) to be true; (i) *Rickard* has to regret that Dan was not home, and (ii) *Dan* must not have been home. It is impossible to regret an event that did not occur (as opposed, of course, to regretting the fact that an event did not occur, which is entirely plausible). Since there is no [OP] intervening between the matrix clause and the CP at the point when truth conditions are evaluated in (7b), the semantic module has no trigger to cast the truth of the CP in doubt. In other words, there is nothing in the syntax to tell the semantics that the complement should not be interpreted as true. Hence, the CP gets a factive reading. This can be taken as the default interpretation of CPs.

3.2. *Non-factive Verbs (With or without EV2)*

I now turn to cases in which we find EV2 in Swedish. In (9) there is a CP embedded under the non-factive verb *tror* (*think*). EV2 is evidenced by the position of the finite verb *läste* (*read*) above the negation *inte* (*not*) in the embedded clause.

- (9) Dan tror att Rickard läste inte boken i dag.
Dan thinks that Rickard read not book-the today

[Swe]

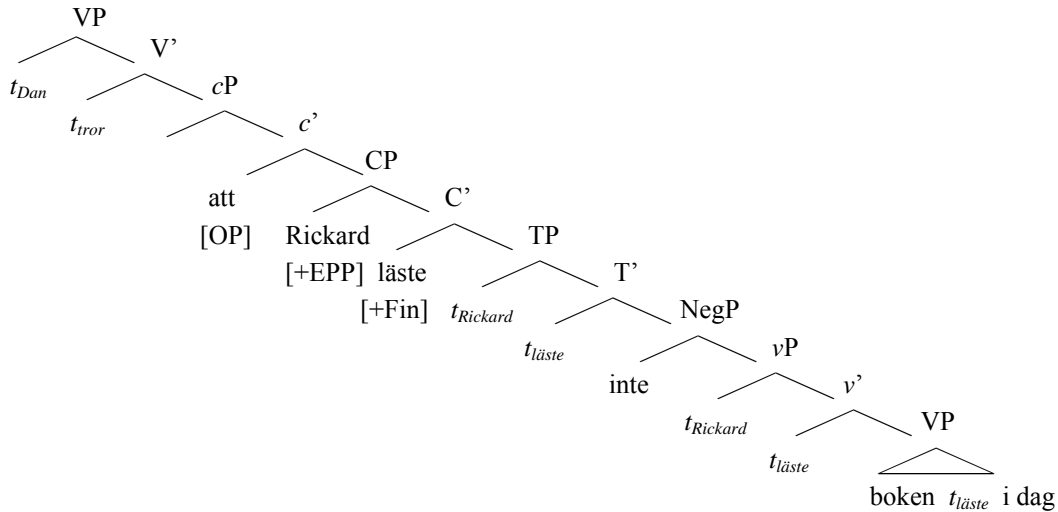

The crucial difference between (9) and (7b) is the presence of *cP*. The verb in (9) selects *cP*, and *c* selects CP (a V2 CP), with the verb *läste* moving to the head of C to check [+Fin] and *Rickard* moving to Spec-CP to check [+EPP].¹⁹ If we think of *cP* as an ‘extender’ of the CP-phase-edge, then the complementizer *att* can merge in *c* instead of C, allowing for V2 movement into CP.²⁰ The details of this extension, or widening of the phase-edge are as follows. When *cP* merges with CP, the specifier and head positions in CP, as well as adjunctions to CP remain active for syntactic processes. The phase-edge of CP is widened to include both the edge of CP and the edge of *cP*. This edge-widening operation is not to be confused with the ‘phase extension’ of den Dikken 2006, 2007, where a phase is extended by head movement, but the original phase loses its phasal status. In my theory, the original phase projection maintains its phase-edge status, leaving C, SpecCP, and adjunctions to CP available for further syntactic operations despite the presence of *cP*. Additionally, I have assigned no [+EPP] feature to *cP*, so no specifier

¹⁹ In (9), non-subject XPs such as *i dag* or *boken* could move to Spec-CP and check [+EPP] instead of *Rickard*.

²⁰ Unlike CP, *cP* has neither a [+Fin] nor an [+EPP] feature. Therefore, it does not attract the finite verb or require lexical material. If we think of *cP* as an extension of CP, then the option of merging *att* in either head position (*c* or C) in the extended projection emerges.

ever projects from *cP*. This lack of a Spec*cP* will play an important role in accounting for *wh*-movement patterns through the *cP/CP* complex.

In (10), we have a non-factive structure without EV2. This must also be possible, given the optionality of EV2 in Swedish.

- (10) Dan tror (att) Rickard inte läste boken i dag. [Swe]
Dan thinks that Rickard not read book-the today

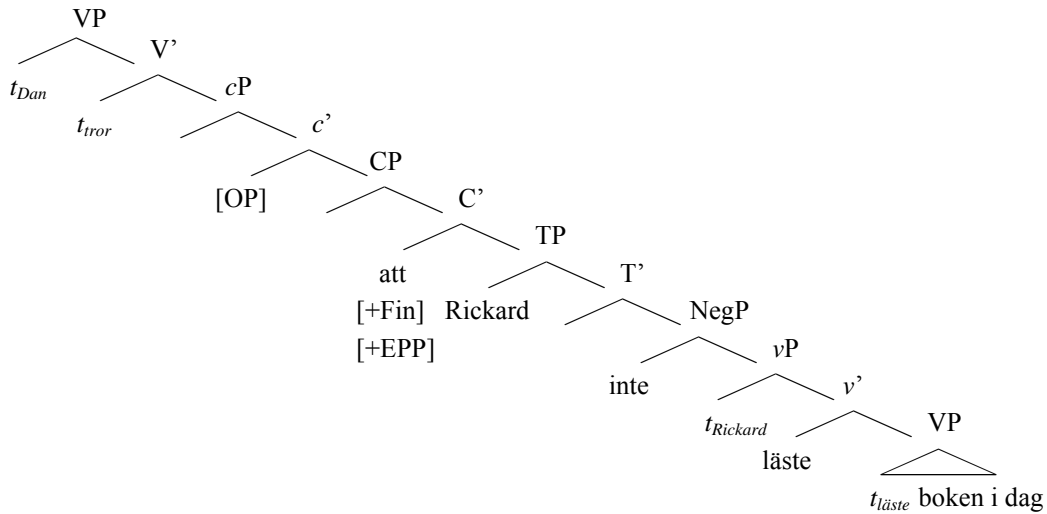

In this case, *att* merges in C (unlike (9), where it merges in *c*), blocking EV2 movement. The merge of *att* satisfies the finite feature, leaving the EPP to be checked. Two possible explanations for EPP checking in (10) are available; the first being that the complementizer checks the EPP feature as well, and the second being that there is no EPP feature in C in these cases. Either case will insure that there is no motivation for XP movement to SpecCP, and that no violation of the ‘Doubly Filled COMP Filter’ is predicted.

The presence of *cP* containing [OP] above CP in (9) and (10) insures that the semantic component will not include the actual world in the evaluation set of worlds when calculating the truth-value of the embedded CP. In a sentence like (9) or (10) for example, the embedded clause would be evaluated as true in the set of all worlds compatible with what Dan believes. Since the [OP] eliminates the actual world from the evaluation set of worlds for the embedded clause, there is a separate evaluation of the

truth of the embedded CP from the evaluation of truth for the matrix clause. Without the intervention of *cP* and the [OP], all CPs are otherwise evaluated as true in the actual world. This explains the presupposition of truth in factive complements, as they do not have a *cP* or [OP], so they must be evaluated as true in the actual world. The details of the semantic contribution of the operator are discussed in the appendix.

Another fact about EV2 in Swedish is that EV2 clauses are islands for *wh*-extraction. This fact is accounted for in the structure in (9). The topicalized V2 constituent *Rickard* moves to Spec-CP, blocking this position for A-bar *wh*-movement. Movement to Spec-*cP* would disobey locality, skipping the A-bar position Spec-CP.

Extraction is possible out of non-EV2 embedded clauses such as (10). Examining the structure in (10), we see that Spec-CP is an available A-bar position for movement. A *wh*-phrase can escape through this position obeying locality conditions and phase construction rules. Once in Spec-CP, a *wh*-phrase reaches the edge of the phase and is available for further movement up the tree. Crucially, I propose that *cP* extends the phase; meaning that CP is still available for syntactic operations after *cP* is merged with the selecting non-factive verb.

3.3. *Positional and Phonological Optionality of the Complementizer*

The idea that *cP* is an extension of the CP projection also gives an explanation for the ability of the complementizer *att* to merge in seemingly different positions (*c* in (9) and C in (10)). I assume that *att* is in the numeration for embedded CPs, but also that *att* is not what projects the CP; it is simply associated with it, so much like an expletive, it is a place holder for a phrase. This expletive-type lexical item serves to give phonological realization to the CP (or CP complex).

As shown in (11), the complementizer *att* is optional under non-factive verbs when there is no EV2. (11) is the same as (10), except that the complementizer is not overt in (11). As we have seen, the complementizer is obligatorily present when there is EV2, as in (9), and also under factives, as in (7b).

- (11) Dan tror Rickard inte läste boken i dag. [Swe]
Dan believes Rickard not read book-the today
 ‘Dan believes that Rickard didn’t read the book today.’

Note that in both (9) and (7b), the complementizer is directly selected by the verb, while in the (10), the optional complementizer is directly selected not by the verb, but by *c*. In a sense, I analyze the ability to drop a complementizer at PF in the opposite way from the classical L-marking story of Iatridou & Kroch 1992, which says that a complementizer can only be dropped when it is L-marked (directly theta-governed).²¹ For me, the opposite holds: the complementizer can only be dropped at PF when it is NOT directly governed by a lexical verb. As the notion ‘government’ has fallen out of favor in the current theory, I replace it here with a selectional account. A complementizer must be phonologically present when selected by a lexical verb. In my account, CP is only directly selected by factive verbs, and complementizers in directly selected CPs may not be dropped. I argue that lexical selection can be disrupted if the contents of a lexically selected head differ from what the selector is subcategorized for.²² Since a factive CP is lexically selected, its contents must match the subcategorization requirements of which select for a lexical complementizer. Non-factive CPs, on the other hand, are selected by the functional head *c*, which has no lexically specified subcategorization requirements. Categorical selection is enough.

Evidence that there are indeed two different merge positions for the complementizer in the CP-field comes from Frisian. Zwart (1993:23) presents complementizer agreement data from Frisian.

- (12) (a) Do kom-st jûn [Fris]
You come-2SG tonight
 (b) ...dat-st do kom-st jûn
...that-2SG you come-2SG tonight

²¹ For a discussion of L-marking, see Chomsky 1986.

²² The idea that selection plays a role in what can appear in the head of a lexically selected complement will be further exploited in Chapter 3, where McCloskey’s (2005) ‘Adjunction Prohibition’ bans head movement to a lexically selected head. Adjunction to a lexically selected phrase also affects selection.

In (12b) the complementizer agrees with the second person singular subject *do*. Frisian, like Swedish, allows EV2 in some embedded clauses. Zwart (1993:25) describes the limitation as being that EV2 only occurs in the complements of the class of verbs Hooper & Thompson identify as allowing root phenomena in their complement clauses. Zwart (2001:42, 2006:67) shows that complementizer agreement is absent in EV2 clauses in Frisian, as in (13).

- (13) (a) Heit sei dat-st do soks net leauwe moa-st [Fris]
Dad said that-2SG you such not believe must-2SG
 “Dad said that you must not believe such things”
 (b) Heit sei dat-(*st) do moa-st soks net leauwe
*Dad said that-(*2SG) you must-2SG such not believe*
 “Dad said that you must not believe such things”

In (13a), the modal *moast* is in sentence final position, so it presumably has not moved up to the CP field.²³ In this case, the complementizer agrees with the subject. In (13b), *moast* has moved to second position in the embedded clause, preceded by the subject *do*, and the complementizer does not agree. I take the difference in complementizer agreement to signal a difference in complementizer positions; in (13a), the case with no verb movement, the complementizer is in C, while in (13b), the verb second case, the complementizer is in *c*. Zwart 1993 analyzes complementizer agreement to be a reflex of AgrS-to-C movement; when AgrS-to-C movement takes place (13a) there is agreement, and when it does not take place (13b) there is no agreement. Translated into my system, this would mean that agreement in C would result from T-to-C movement.²⁴ In (13a) there is no EV2, and I analyze the complementizer *datst* to be in C (as in non-EV2 (10)). Following Holmberg & Platzack 1995, there is no V-to-T movement independent of V-to-T-to-C movement in Germanic EV2 languages, so the finite verb remains in V in

²³ Zwart’s (2001) analysis has *moast* (must) moving to I, not as far as C. C is not included in the F-chain of V in this case, so no agreement occurs. Zwart analyzes the difference between (13a) and (13b) as a difference in F-relatedness. In (13a) the verb’s LEX-features do not move to C, as the complementizer provides LEX-features. However, the F-features of V do move to C, and agreement occurs. In this case, the F-chain is {C, Infl, V}. In (13b), C is not included in the chain of F-related elements. In this case, the F-chain is {Infl, V}. LEX-features must be spelled out at the head of the chain.

²⁴ I follow Zwart’s claim that an AgrS-to-C-type movement occurs (T-to-C for me), but differ in the details of the analysis beyond that.

(13a). In this case, we find complementizer agreement with the 2nd-person subject *do*, so we get the agreeing form *datst*. Following Zwart 1993, I claim that this agreement is down to T-to-C movement (AgrS-to-C in Zwart’s framework). In (13b) we see EV2 movement has taken place, which I analyze as involving movement of the finite verb to C (as in EV2 (9)). I differ from Zwart 1993 in claiming that the finite verb *moast* has moved from V-to-T-to-C, and we find agreement on the verb in C, which agrees with the 2nd-person subject *do*.²⁵ We have an agreeing form in C, and there is no reason to expect the complementizer *dat* in *c* to agree since I have not proposed any C-to-*c* movement.

A similar case from Frisian is presented by deHann & Weerman (1986:85), this time with the availability of clitic subjects. The clitic subject *er* (*he*) is a variant of the non-clitic *hy*. Both options are available after a lexical complementizer, as in (14a), but the clitic cannot appear sentence initially (14b).

- (14) (a) Pyt sei dat hy/er my sjoen hie [Fris]
Pyt said that he me seen had
 “Pyt said that he had seen me”
 (b) hy/*er hie my sjoen
he had me seen
 “He had seen me”

However, when there is EV2 movement, as in (15), the clitic is no longer possible.

- (15) Pyt sei dat hy/*er hie my sjoen [Fris]
Pyt said that he had me seen
 “Pyt said that he had seen me”

I take C to be the clitic hosting position in (14a). The clitic in (14a) cliticizes to the lexical complementizer, which in a non-EV2 clause is in C. In EV2 cases like (15), I analyze the complementizer as being in *c*, and the finite verb in C. Additionally, EV2 movement requires that an XP, in this case the pronoun, move to SpecCP, not a clitic position. This is also the case in the matrix V2 clause in (14b), where the clitic form is also ruled out. Only in (14a), where the complementizer is in C, is the clitic possible. I

²⁵ For Zwart the V moves only to AgrS, so there is no chain of agreement with C and thus no C-agreement.

take the Frisian facts in (12-15) as evidence that the complementizer in EV2 clauses is in a higher structural position (in *cP*) than in non-EV2 clauses (in *CP*).²⁶

3.4. *Negative Verbs, Negated Non-factive Verbs and Irrealis Verbs (No EV2)*

In this section I examine contexts in which EV2 is prohibited under non-factive verbs. I argue that *cP* is still present in these cases, as it is necessary for semantic interpretation. However, movement possibilities are restricted because of a change in the nature of the [OP] under certain syntactic conditions. In her dissertation, Laka (1990) presents arguments for the existence of negative complementizers that are licensed by negative verbs and matrix negation, and shows how they in turn license Negative Polarity Items (NPIs) in complement clauses. I propose that in Swedish, the complementizer is not negative, but that instead the [OP] is. When licensed by matrix negation or inherently negative verbs, the [OP] matches the features of the licenser, much like the Laka 1990 negative complementizer.²⁷ The negative feature I propose is a purely syntactic feature, with no semantic effects. The fact that the [OP] bears a negative feature in these environments explains a pair of syntactic effects.

First, as with non-negated non-factive verbs, negated non-factive verbs can appear with or without a complementizer. This is shown in (16), where the [OP] bearing a negative feature is represented by [N-OP].

²⁶ deHann & Weerman (1986:84) report that in Frisian, unlike Swedish, the complementizer is optional in EV2 clauses. In other words, Frisian can pattern with German, which allows EV2 if the complementizer is not present, but can also pattern with Swedish, which allows EV2 only in the presence of a lexical complementizer. Neither Swedish nor German allow optional complementizers with EV2 – for German the complementizer must be absent, and for Swedish it must be present. At present I have no explanation for the Frisian facts. One possible analysis would be that the PF-licensing conditions on complementizers are different in Frisian. Another possibility is that Frisian allows two different derivations, a German-style with no complementizer in the numeration, and a Swedish-style derivation with the complementizer present and in *c*. I leave a more thorough examination of the Frisian facts to future research.

²⁷ Long distance NPI licensing will be discussed in more detail in Chapter 4.

- (16) Jag tror inte (att) Rickard inte läste boken i dag.
I believe not (that) R. not read book-the today

[Swe]

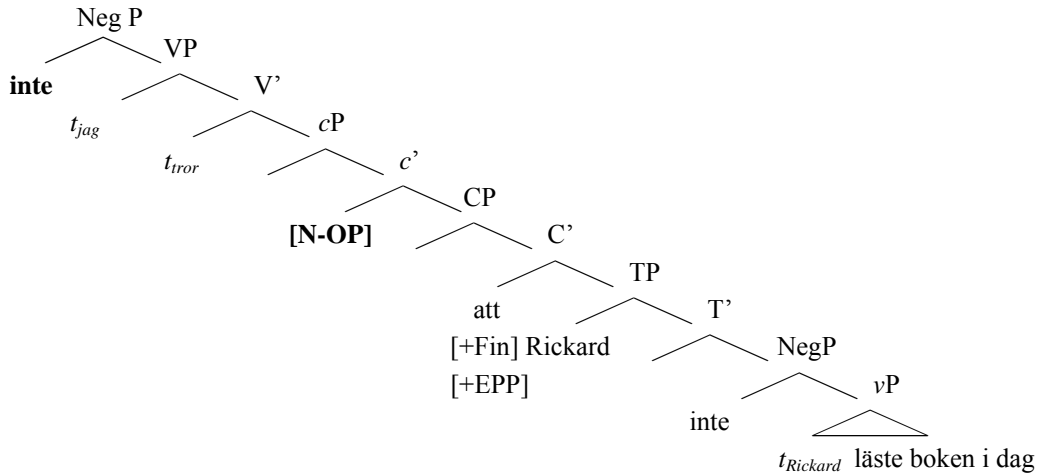

Unlike Basque, Swedish and English lack separate lexical negative and non-negative complementizers; *att/that* appears in both contexts. I take *that* and *att* to be declarative complementizers that bear no negative features. I therefore take the [OP] and the complementizer to be separate entities, and also see them as being non-compatible in the same head.²⁸ If *att/that* were to merge with the [N-OP] in *c*, there would be a feature mismatch, crashing the derivation. Therefore, the only possibility for *att* to merge in (16) is in C, blocking EV2. The analysis is essentially the same for irrealis complements. An irrealis verb like *önska* (*wish*) or *hoppas* (*hope*) licenses an irrealis [I-OP], which also results in a feature mismatch if merged with an indicative complementizer like *att*.²⁹ Modalized non-factive verbs (*skulle* (*would*) + V, *borde* (*should*) + V, etc.) behave like *önska* (*wish*) and *hoppas* (*hope*). EV2 is not allowed in their complements, and *att* is optional. The derivations for these constructions work in the same way as (16).

²⁸ For more discussion of the separation of the [OP] and the Complementizer, see chapter 4.

²⁹ There are some irrealis predicates such as *föredra* (*prefer*) and *insistera på* (*insist (on)*) that require *att* to be present. My proposal predicts that these verbs, which are non-factive, should have the option to omit the complementizer. I leave aside this class of irrealis predicates (*insist*, *prefer*, *demand*, etc.) for future research. A similar problem arises for inherently negative verbs like *betvivla/tvivla på* (*doubt*) and *förneka* (*deny*). These predicates work in the same way as negated non-factive verbs, but they also take obligatory *att*. The English translations of these verbs behave as expected, with *that* being optional. I will also leave these verbs aside now, with the hope that future research will bring a better understanding of what different properties they have in Swedish.

3.5. Summary

In this section I implemented the extra structure proposed in section 2 to account for EV2 facts in Swedish. I showed that extra structure (*cP*) is selected by non-factive verbs, and the *cP* and [OP] can be exploited to explain a number of phenomena, including limited EV2, the optionality of the complementizer *att*, and non-local NPI licensing. Also presented was a principled way to strictly limit CP-recursion, and syntactic and semantic motivation for the extra structure and operators. In the next section I give more evidence for *cP* from Hungarian.

4. Hungarian

In this section I give evidence for the proposed extra structure from a non-Germanic language. Hungarian exhibits extra morphology in non-factive verb contexts, which I interpret as additional evidence for the existence of *cP*. This extra morphology, which appears to be generated in the CP field, is associated with a non-factive interpretation of CP. This morphology, which I analyze as being generated in a separate syntactic position from the complementizer, seems to go against the Kiparsky & Kiparsky 1971 (K&K henceforth) prediction, discussed in Chapter 1, that extra structure (associated with the head noun *fact*) should be associated with a factive interpretation.

4.1. Hungarian ‘Azt’

As in Swedish, Hungarian embedded clauses exhibit two different patterns, one for non-factives and one for factives, as first noted in de Cuba & Ürögdi 2001.

- (17) (a) *Azt hiszem hogy Mari okos.* [Hun]
it-ACC I-think Comp Mary smart-is
'I think that Mary is smart.'
- (b) (**Azt*) *sajnálom hogy Mari okos.*
it-ACC I-regret Comp Mary smart-is
'I'm sorry that Mary is smart.'

In (17a), the pronominal element *azt* originates in complement position, and moves to sentence-initial position, representing the embedded CP.³⁰ This pronoun is only present in cases where the matrix predicate is non-factive, as shown in (17b).³¹ The fact that *azt* bears accusative case provides evidence that it originates as an argument of the matrix verb. I propose that *azt* originates in *cP*, which is present in the non-factive case but missing with factives. When *azt* is not present in a non-factive context, a factive reading results, as shown in (18).

- (18) (a) *Azt mondta Péter, hogy későn kezdődik a meccs.* [Hun]
that-ACC said Peter Comp late begins the match
 ‘Péter said that the match will begin late’ (but we don’t know if this is true)
- (b) *Mondta Péter, hogy későn kezdődik a meccs.*
said Peter Comp late begins the match
 ‘Péter told (me) that the match will begin late’ (and in fact it will)

The semantic effects of pronominal elements in Hungarian can also be seen with some factive verbs. The pronominal *úgy* (*so*) shows similar semantic effects to *azt* in Hungarian (Enikő Tóth, Barbara Ürögdi, p.c.).³² When *úgy* appears with a semi-factive verb like *know*, as in (19b), a non-factive reading results.

- (19) (a) *Tudja János, hogy Mari okos.* [Hun]
knows John that Mary smart-is
 ‘John knows that Mary is smart’
 (factive reading)

³⁰ For an analysis along these lines, see Lipták 1998, as discussed by Kiss (2002:234-5).

³¹ If the sentences have neutral intonation, then factive predicates don’t allow *azt*, while non-factives do. However, if *azt* is in focus position and heavily stressed, it then becomes grammatical, as in (i) (Enikő Tóth, Barbara Ürögdi, p.c.).

(i) *AZT sajnálom, hogy Mari megbukott a vizsgán.*
 ‘It’s that Mari failed the exam that I’m sorry for.’

A detailed discussion of these cases is outside the scope of this work, but I assume that there is an alternative explanation for the presence of *azt* in this specially marked context. The point is still made with the neutral intonation cases in (17), where there is a clear contrast.

³² Kiss (2002:233) describes *úgy* as an alternative to the demonstrative pronoun *azt*, serving the semantic function of expressing a reservation concerning the truth of the subordinate proposition.

- (b) *Úgy tudja János, hogy Mari okos.*
so knows John that Mary smart-is
'John knows that Mary is smart'
(to the best of John's knowledge, Mary is smart)

The presence of *úgy* in (19b) removes the factive interpretation of the embedded clause, while in the absence of *úgy*, the default factive reading results (19a). I take the facts from Hungarian in this section to provide evidence that *cP* is optional under some verbs. The observed semantic differences in factivity are due to the presence or absence of *cP*, not simply the lexical semantics of the verb.

4.2. *Summary*

In this section I have presented morphological and semantic evidence from Hungarian that a non-factive reading is associated with more structure in the CP field, not less (contra K&K). The absence of this structure leads to a factive interpretation, and its inclusion leads to a non-factive interpretation. This fits well with the Mainland Scandinavian EV2 facts, and my analysis on non-factivity being associated with a more articulated CP-field.

5. **What Verbs License EV2?**

Having presented a mostly syntactic analysis for the different syntactic effects associated with factive and non-factive complement clauses, I will now explore more closely the semantic categorization.³³ It turns out that the classification “factive vs. non-factive” is not the best categorization for the groups of verbs that allow or disallow EV2. In this section I review various proposals for categorizing verbs and select what I find to be the most accurate classification.

³³ For a summary of some of the syntactic and semantic issues surrounding embedded root phenomena that I discuss in this chapter, see Heycock 2000/2006.

5.1. *Factivity and Assertion*

As discussed in Chapter 1, K&K discuss the syntax-semantics interface in the English complement system. They describe two classes of predicates, those that do not presuppose the truth of their sentential complements, like *believe* in (20a) (non-factives) and those that do presuppose the truth of their complements, like *regret* in (20b) (factives).

- (20) (a) I believe [that it is raining].
(b) I regret [that it is raining].

This presupposition difference remains in the case of matrix negation, as in (21).

- (21) (a) I don't believe [that it is raining].
(b) I don't regret [that it is raining].

K&K also note that this semantic classification is reflected in the different syntactic behavior of complementation for the two types of predicate. Among these differences were the following.

- (22) Only factive predicates can have as their objects the noun *fact* with a gerund or *that*-clause:
(a) Factive: I want to make clear the fact that I don't intend to participate.
(b) Non-factive: *I assert the fact that I don't intend to participate. (K&K:347)
- (23) Gerunds can be objects of factive predicates, but not freely of non-factive predicates:
(a) Factive: I regret having agreed to the proposal.
(b) Non-factive: *I believe having agreed to the proposal. (K&K:347)
- (24) Only non-factive predicates allow the accusative and infinitive construction (ECM):
(a) Non-factive: I believe Mary to have been the one who did it.
(b) Factive: *I resent Mary to have been the one who did it. (K&K:348)

To account for the semantic and syntactic differences between factive and non-factive predicates, K&K hypothesize that presupposition of complements is reflected in their

syntactic deep structure. In the framework they were working in, the structure for sentences like those in (20) is (25).

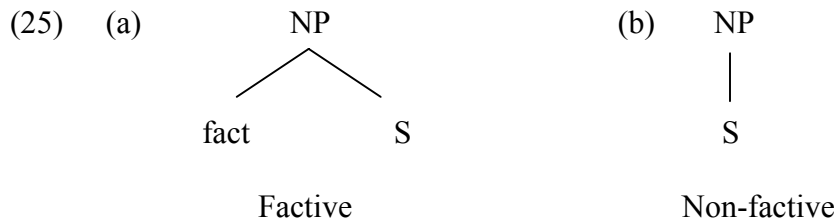

Two optional transformations provide the surface structure in (22-24); deletion of the head noun *fact*, and formation of gerunds from *that*-clauses in position after nouns. The facts in (22-24) fall out from the structures in (25). (22a) is fine because *the fact* is present in the deep structure and not deleted, but (22b) is out because *the fact* it is not originally there and there is no place to add it in the structure. (23a) derives easily by transformation from the proposed deep structure (again, in the transformational framework of the time), but (23b) is not possible because the gerund formation transformation only occurs after nouns. (24b) is ruled out as a Complex Noun Phrase Constraint (CNPC) violation from Ross 1967, assuming an operation of raising to object.

While initially promising, the K&K analysis proved to be problematic. For example, ruling out (24b) as a CNPC violation would lead one incorrectly to expect (26a) and (27a) to be ungrammatical, given the ungrammaticality of the WH-extraction in (26b) and (27b).

- (26) (a) What do you resent that Mary did *t* ?
 (b) *What do you resent the fact that Mary did *t* ?
- (27) (a) Who did John discover that Mary is dating *t* ?
 (b) *Who did John discover the fact that Mary is dating *t* ?

In the present analysis, selectional properties of the verb classes explain the contrasts in (22) and (23); factives like *make clear* and *regret* select for nominal phrases like CP, NP,

and gerunds, while non-factives generally don't – they select *cP*, which I do not consider a nominal.³⁴

While I follow K&K's claim that a semantic difference is responsible for a syntactic differences above, my syntactic analysis differs greatly. Essentially, I come to the opposite conclusion, that it is *non-factives* that are associated with extra structure. In addition, upon closer inspection the factive vs. non-factive semantic distinction was found not to be fine grained enough.

Hooper & Thompson (1973) (H&T henceforth) examine contexts in which root phenomena occur in embedded clauses in English. They conclude that root phenomena can only occur in clauses that are 'asserted'.³⁵ They divide factive and non-factive verbs into five distinct groups according to whether or not their sentential complements can be asserted. These are given in (28). Heycock 2000/2006 summarizes H&T's 5-way division in (29). This division cuts across factivity lines, with *A*, *B* and *E* being asserted, and *C* and *D* not asserted.

(28) **Hooper & Thompson 1973**

Non-factives

Class A: say, report, assert, claim, be obvious, be sure

Class B: think, suppose, believe, imagine, it seems, it appears

Class C: doubt, deny, be (un)likely, be (im)possible, be (im)probable,

Factives

Class D: resent, regret, bother, be sorry, be strange, be interesting

Class E: realize, learn, discover, know, recognize, find out

³⁴ The selectional differences between factives and non-factives is discussed in more detail in Chapter 5.

³⁵ For a critique of H&T's claim that root phenomena can occur in all and only asserted clauses, see Green 1976, as discussed in Heycock 2000/2006.

(29) **Class A predicates** (e.g. *say, report, be true, be obvious*) The verbs in this group are all verbs of saying. Both the verbs and the adjectives in this group can function "parenthetically", in which case the subordinate clause constitutes the main assertion of the sentence. It is claimed however that if the subordinate clause occurs in subject position (as in, e.g. "That German beer is better than American beer is true") it is not asserted.

Class B predicates (e.g. *suppose, expect, it seems, it appears*) In this group also the predicates can function parenthetically, and in this case the subordinate clause is asserted. The distinction between this group and Group A is not made entirely clear, although it is noted that Class B predicates allow "Neg raising" and tag questions based on the subordinate clause.

Class C predicates (e.g. *be (un)likely, be (im)possible, doubt, deny*) have complements which are not asserted.

Class D predicates (e.g. *resent, regret, be odd, be strange*) these factive predicates have complements which are argued to be presupposed, and hence not asserted.

Class E predicates (e.g. *realize, know*) these semifactives (factives that lose their factivity in questions and conditionals) have a reading on which the subordinate clause is asserted. (Heycock 2000:18, underlining mine)

Andersson (1975:31-35) offers a modification of these five groups, providing a large amount of data from Swedish. Included in Andersson's data are verbs that license EV2, and these mirror H&T's verbs that allow embedded root phenomena in English. However, Andersson modifies H&T's classification by collapsing Class C with Class B. He notes that in Swedish, *är troligt* (*is likely*) and *är möjligt* (*is possible*) are not so resistant to root transformations, so they should be included in Class B. Class C would then consist of only negative predicates like *tvivla* (*doubt*) and *förneka* (*deny*), and the negative counterparts to *är troligt* (*is likely*) and *är möjligt* (*is possible*), *är otroligt* (*is unlikely*) and *är omöjligt* (*is impossible*). Andersson also notes that predicates in Class B are resistant to root transformations when negated, so Class C would consist of negative versions of Class B predicates.

(30) **Andersson 1975**

Class A: say, report, assert, claim, be obvious, be sure

Class B: think, suppose, believe, imagine, it seems, be likely, be possible

Class C: doubt, deny, be unlikely, be impossible, be improbable

Class D: resent, regret, bother, be sorry, be strange, be interesting

Class E: realize, learn, discover, know, recognize, find out

As with H&T's list, Class A, B and E allow root transformations, while Class C and D don't. Neither H&T nor Andersson give a syntactic analysis using their classifications, relying instead on a semantic/functional description of the phenomena in question. For them, root transformations are simply blocked in non-asserted clauses.

5.2. *Stance Verbs and Familiar Complements*

Cattell 1978, in an investigation of *why*-extraction in English, modifies H&T's categorization of predicates that take sentential complements. He divides these verbs into three classes: Volunteered-stance, Response-stance, and Non-stance. The classes are divided by appealing to a notion of shared background belief in a discourse. Each class selects a different status of complement clause, with the status having to do with the content of the complement clause in regards to the body of shared background beliefs. A partial listing of the verbs in Cattell's classes is given in (31), and Hegarty's summary of the classes is in (32).

(31) **Cattell 1978**

Volunteered-stance verbs: claim, report, decide, think, say, feel, assume

Non-stance verbs: regret, doubt, emphasize, remember, forget, recognize

Response-stance verbs: confirm, admit, accept, deny, agree

(Cattell 1978:77)

- (32) **Volunteered-stance**: The content of the complement is being offered by the speaker for inclusion in the body of background beliefs

Non-stance: Presuppose, as a matter of conventional meaning, that the content of the complement is part of the body of background beliefs. This class includes most standard factive verbs.

Response-stance: The content of the complement is under consideration for inclusion in the body of background beliefs. This class includes the non-factives *confirm* and *verify*, and the negative verbs *deny* and *doubt*.
(Hegarty 1992:footnote12)

As Hegarty notes, the classification in (32) represents another departure from the traditional factive vs. non-factive distinction. Cattell (1978:69) shows that adverbial *wh*-extraction in English is only possible out of complements to Volunteered-stance verbs, as illustrated in (33).³⁶ Cattell notes that only Volunteered-stance (VS) verbs can occur with ambiguous *why*, whereas Non-stance (NS) and Response-stance (RS) verbs do not show this ambiguity:

- (33) (a) Why do they think (that) Sue killed Harry? (VS – ambiguous)
(b) Why do they accept that Sue killed Harry?³⁷ (RS – not ambiguous)
(c) Why did Richard comment that Sue killed Harry? (NS - not ambiguous)

While *why* in (33a) can be interpreted in the matrix or embedded clause, in (33b) and (33c) only the matrix reading is available. *Why*-extraction thus seems to be available only from complements of VS verbs as opposed to NS or RS verbs. Clearly, the ‘stance’ verb classification provides a more accurate classification for the *why*-extraction facts than a factive vs. non-factive distinction, as a number of the verbs blocking *why*-extraction from their complements are non-factive (*accept*, *agree*, etc.).

Hegarty 1992 classifies verbs in a manner similar to Cattell. His ‘Class A’ predicates are identical to Cattell’s VS class, and his ‘Class B’ predicates are a union of

³⁶ Extraction will be discussed in detail in Chapter 3.

³⁷ I have changed the verb from Cattell’s original *deny* to the RS verb *accept* because I would (as does Hegarty) classify *deny* as an inherently negative verb, and it therefore patterns differently. I return to this point below.

RS and NS verbs with negative verbs such as *deny* and *doubt* removed. Hegarty's predicate classification is given in (34).

(34) **Hegarty 1992**

Class A: believe, think, say, claim, assert, allege, declare, state, propose, suggest, assume, suppose, conjecture, suspect, consider, imagine, be likely, be possible

Class B: notice, point out, realize, recognize, forget, admit, emphasize, regret, know, remember, conclude, confirm, verify, learn, find out, inform, agree, accept, insist, stress, hate, like, be aware, be significant, be odd, be glad, be proud

The predicates in Hegarty's Class A allow adverbial *wh*-extraction from their complements, while those in Class B allow adverbial *wh*-extraction only when their complements express 'non-familiar' content. Hegarty argues that Class B predicates are syntactically marked if they meet various background knowledge criteria in the discourse, or the linguistic or pragmatic context. A syntactic feature Familiar [F] is added to C in 'familiar' complements, with [F] formulated in (35).

(35) **F = assumed by the speaker to be familiar to the listener**

This notion of familiarity is construed as a relation between the listener, the content of the complement clause, and the linguistic and pragmatic context. This relation can be satisfied under any of the circumstances given by Hegarty in (36).

- (36) (a) The content of the complement has been established earlier in the discourse so that it is thereafter presupposed in the discourse.
- (b) The content of the complement is background knowledge that the listener brings to the discourse, where the relevant background knowledge is evoked by something in the linguistic or pragmatic context.
- (c) The content of the complement has been established earlier in the discourse as a point at issue or of controversy, or a point of discussion in the discourse, and is not necessarily presupposed.
- (d) The content of the complement is a point of discussion that is evoked for the listener by something in the linguistic or pragmatic context.
- (Hegarty 1992:8)

Hegarty argues that the feature [F] marks the complementizer node of familiar Class *B* verb complements (not of ‘novel’ Class *B* verb or any Class *A* verb complements), and that this feature marking blocks adverbial *wh*-extraction from F-marked complements.³⁸

An important finding by Hegarty is that his verb classification closely fits the list of Danish verbs that allow EV2 and those that do not provided in Vikner 1995, reproduced in (37).

(37) **Vikner 1995**

- (a) Danish verbs that allow sentential complements with (and without) EV2:

antydde <i>hint</i>	angive <i>indicate</i>	svare <i>answer</i>	påstå <i>claim</i>	berette <i>report</i>
betone <i>emphasize</i>	beslutte <i>decide</i>	erfare <i>learn</i>	huske <i>remember</i>	slå fast <i>ascertain</i>
synes <i>think</i>	tro <i>believe</i>	håbe <i>hope</i>	mene <i>mean</i>	sige <i>say</i>
se <i>see</i>	føle <i>feel</i>	formode <i>assume</i>	vide <i>know</i>	

³⁸ For a details of the technical workings of the blocking effect, the reader is referred to the discussion in Hegarty (1992:27-33). For Hegarty, the difference in extraction availability is down to whether or not there has been an extension of syntactic domains due to head movement.

(b) Danish verbs that allow sentential complements, but not EV2:

beklage <i>be sorry</i>	bekræfte <i>confirm</i>	fortryde <i>regret</i>	bevise <i>prove</i>	tvivle på <i>doubt</i>
bede om <i>ask for</i>	tænke på <i>think of</i>	tillade <i>permit</i>	holde hemmeligt <i>keep secret</i>	
være glad for <i>be happy</i>	hade <i>hate</i>	overse <i>overlook</i>	overbevise om <i>convince</i>	
tillgive <i>forgive</i>	forlange <i>demand</i>	fortie <i>conceal</i>	vise <i>show</i>	indrømme <i>admit</i>

(Vikner 1995:71-72)

All the predicates listed that allow EV2 select (or can select) what Hegarty calls ‘novel’ complements. The list in (37a) includes Class A verbs that typically express novel content, like *sige* (*say*), *tro* (*think*), *føle* (*feel*) and *formode* (*assume*), and those which Hegarty argues can take novel or familiar content, like *erfare* (*learn*), *huske* (*remember*), *beslutte* (*decide*) and *slå fast* (*ascertain*).³⁹ All the non-EV2 predicates listed in (37b) are either intrinsically negative or take familiar complements, which Hegarty argues have either negative [N] or familiar [F] features blocking CP-recursion.

Hegarty’s analysis ties the facts together neatly, showing that the class of verbs that allow EV2 and the class that of verbs that allow *why*-extraction closely overlap. As far as I know, Hegarty is the first to have noticed this generalization. I take this overlap as a signal that the semantic classes proposed in Cattell 1978 (and modified in Hegarty 1992) to be on the right track, meaning that the traditional factive vs. non-factive distinction does not hold the key to EV2 or factive islands. While factivity may be a useful notion, it is not the defining semantic notion with these phenomena. Instead, a

³⁹ Hegarty mentions *betone* (*emphasize*) as the only entry that might defy the generalization. The reader may notice that *know* appears in Hegarty’s Class B predicates given in (34), while *vide* (*know*) is on Vikner’s list of verbs that allow EV2 in Danish (37a). According to the analysis in this chapter, we would not expect EV2 to appear under a familiar predicate like *know*. However, as Hegarty (1992:13) notes, semifactives like *know*, *point out*, and *notice* are able to select either a familiar or a novel complement. In my analysis, this class of verbs are able to select for either *cP* or select CP directly. Syntactic and semantic differences result from the presence or absence of the *cP* structure, not from the lexical semantics of the predicate. For more discussion of optional *cP* with particular predicates, see Chapter 4.

notion of context change turns out to be more relevant, closer to the H&T intuition that assertion is what matters.

I follow the Cattell/Hegarty idea that what is important is when the speaker changes (or tries to change) the context of discourse. However, while Hegarty argues that it is the familiar, or contextually given information that requires special marking (just as K&K argue that factives need special treatment), I argue that it is the new, context changing information that is marked, both semantically, with an operator, and syntactically, with a syntactic functional projection. Thus a revision of the basic structures I proposed in (4) and (5) is in order, which are changed to (38) and (39) respectively. Class A and Class B are adopted from Hegarty 1992.

(38) **Class B verbs with *familiar* complements (no context change)**

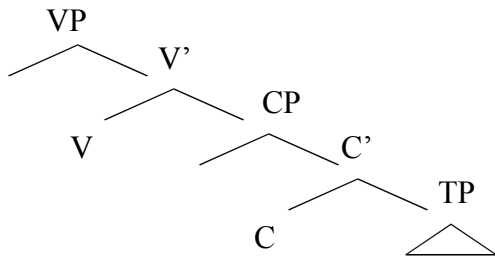

(39) **Class A verbs, Class B verbs with *novel* complements (context change)**

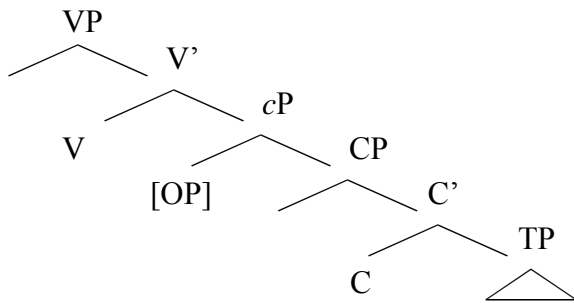

6. Icelandic and German

Given the analysis presented in this chapter, questions arise as to how the present proposal translates into other Germanic languages that allow EV2. German, like the Mainland Scandinavian (MSc) languages, allows EV2 under Novel Complement-taking Predicates (NCPs) (40), and disallows EV2 under Familiar Complement-taking Predicates (FCPs) (41). Vikner's (1995:71-72) list of Danish EV2 and non-EV2 taking predicates in (37) has corresponding predicates in German which behave in the same way as Danish in allowing or disallowing EV2. However, while MSc languages only allow EV2 in the presence of an overt complementizer, German only allows EV2 in the absence of an overt complementizer, as in (40b). The complementizer is obligatory in a non-EV2 clause in German, as in (40a).

- (40) (a) Er sagt, *(daß) die Kinder diesen Film gesehen haben [Ger]
He says (that) the children this film seen have
'He says that the children have seen this film.'
- (b) Er sagt, (*daß) die Kinder haben diesen Film gesehen
He says (that) the children have this film seen
'He says the children have seen this film.' (Vikner 1995:66)
- (41) (a) Holmes bewies, daß Moriarty nur dieses Geld gestohlen hatte [Ger]
Holmes proved that Moriarty only this money stolen had
'Holmes proved that Moriarty had only stolen this money.'
- (b) *Holmes bewies, dieses Geld hatte Moriarty gestohlen
Holmes proved this money had Moriarty stolen (Vikner 1995:71)

Icelandic differs from both MSc and German in that it exhibits 'general EV2'. Verb second order occurs both under NCPs (42a) and FCPs (42b).

- (42) (a) Jón sagði að þessa bók hefði ég átt að lesa [Ice]
Jón said that this book had I ought to read
'Jón said that I should have read this book.'
- (b) Jón harmar að þessa bók hefði ég átt að lesa
Jón regrets that this book had I ought to read
'Jón regrets that I should have read this book.'
- (Holmberg & Platzack 1995:79)

However, Icelandic shares with German and MSc the property that the complementizer can only be omitted under NCPs (43a), and not under FCPs (43b).

- (43) (a) Jón telur/segir (að) hún hafi farið [Ice]
Jón believes/says (that) she has gone
 (b) Jón harmar/hatar/elskar *(að) hún skuli hafa farið
*Jón regrets/hates/loves *(that) she AUX has gone*
 (Thráinsson 1979:214)

The main differences between the 3 types of languages with respect to EV2 are summarized in (44).

- (44)
- | | | |
|-------------------|---|------------------------------------|
| | <u>EV2</u> | |
| Swedish: | Only under NCPs | (Limited EV2) |
| German: | Only under NCPs | (Limited EV2) |
| Icelandic: | Under NCPs and FCPs | (General EV2) |
| | <u>Complementizer Drop</u> | |
| Swedish: | Only under NCPs | (EV2 disallowed if C dropped) |
| German: | Only under NCPs | (EV2 obligatory if C dropped) |
| Icelandic: | Only under NCPs | (EV2 obligatory with or without C) |
| | <u>EV2 + Complementizer</u> | |
| Swedish: | EV2 only <i>with</i> overt complementizer | (EV2 optional with C) |
| German: | EV2 only <i>without</i> overt complementizer | |
| Icelandic: | EV2 <i>with or without</i> overt complementizer | |

The challenge is to fit the German and Icelandic facts into the analysis of MSc EV2 presented in this chapter. I will start with German, and then return to Icelandic.

The main difference between German and MSc EV2 is the effect of the complementizer. In German, EV2 is obligatory when the complementizer is absent, and disallowed when the complementizer is present. In MSc, EV2 is disallowed when the complementizer is absent, and optional when the complementizer is present. In both German and MSc, EV2 is only allowed under NCPs, and complementizer drop is also only possible under NCPs. My claim is that the structures for both languages are the same, but German, unlike MSc, does not allow complementizers in cP. The difference

between MSc and German comes down to a difference in the selectional properties of NCPs in the languages. In MSc, NCPs can select for a *cP* with or without a complementizer, while German NCPs only select for *cP*s without a complementizer. The structure for (40a), a German non-EV2 sentence with the complementizer, is given in (45a). The structure for (40b), a German EV2 sentence without a complementizer is given in (45b).

- (45) (a) Er sagt, *(daß) die Kinder diesen Film gesehen haben [Ger]
He says (that) the children this film seen have

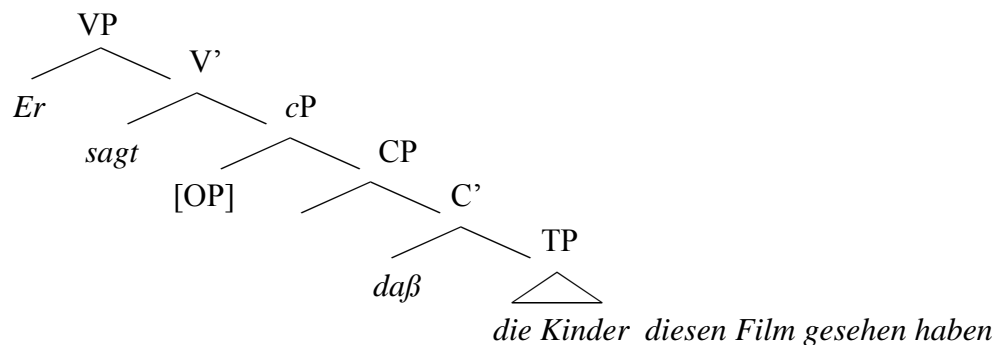

- (b) Er sagt, (*daß) die Kinder haben diesen Film gesehen
He says (that) the children have this film seen

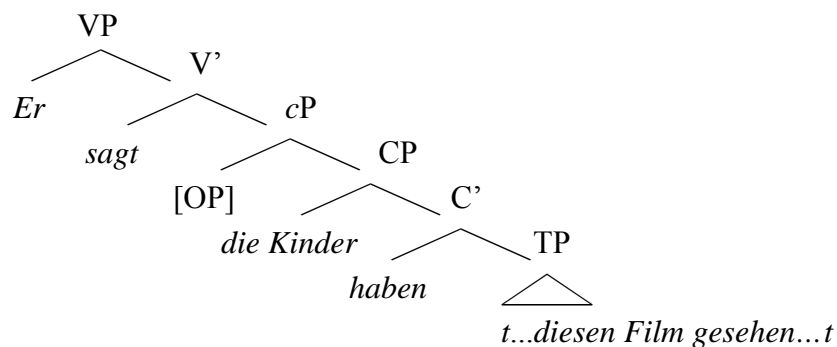

Since the complementizer *daß* cannot appear in *cP* in German, EV2 in the presence of a complementizer cannot occur, because an overt complementizer in CP will block V2 movement.

Now turning to Icelandic, the main difference between Icelandic on one hand and German and MSc on the other is that Icelandic has 'general EV2', and German and MSc

have 'limited EV2'. In Icelandic, EV2 is obligatory under both NCPs and FCPs, while EV2 in German and MSc is limited to NCP complements. However, all three language types limit complementizer drop to NCP complements. Diesing 1990, Santorini 1992 and Iatridou and Kroch 1992, among others, have argued that languages with unrestricted EV2 like Icelandic differ from limited EV2 languages in that the target of EV2 movement in Icelandic is IP, as opposed to CP in German and MSc.⁴⁰ If this analysis is correct, then differences in the CP level (i.e. the presence or absence of cP) should have no effect on Icelandic EV2. This is the case, as shown in (46), which gives structures for the examples in (42). Since EV2 occurs at the IP level, the presence of cP under a NCP (46a) or its absence under a FCP (46b) has no effect. We find EV2 in both cases.

- (46) (a) Jón sagði (að) þessa bók hefði ég átt að lesa [Ice]
Jón said (that) this book had I ought to read

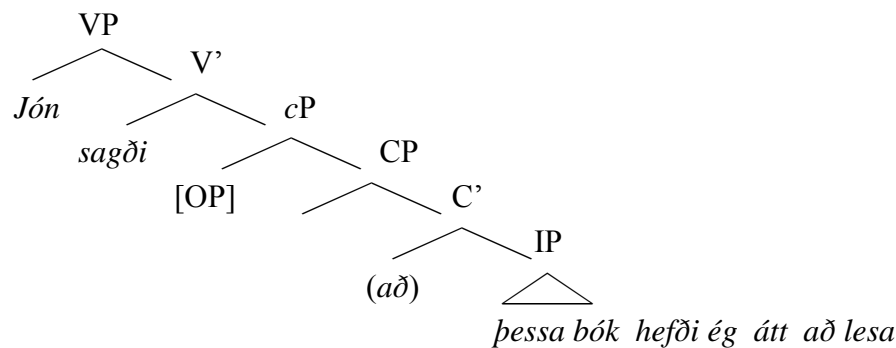

- (b) Jón harmar að þessa bók hefði ég átt að lesa
Jón regrets that this book had I ought to read

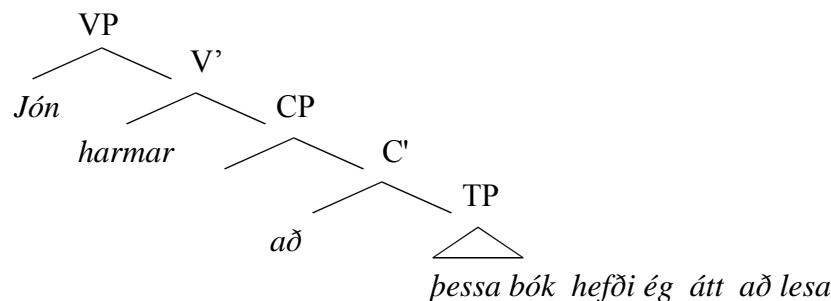

⁴⁰ For arguments in favor of a CP-recursion analysis of Icelandic EV2, see Vikner 1995.

However, the presence or absence of *cP* still has syntactic and semantic effects. In (43) we saw that complementizer drop in Icelandic is only possible under NCPs, as is the case in German and MSc. Here again I appeal to selection to account for the ability for the complementizer to be dropped. As was the case in German and MSc, a CP that is selected by a predicate must contain an overt complementizer. This is the case in (46b), where the FCP *harmar* (*regret*) selects CP. Only in the case of a NCP selecting *cP*, and *cP* selecting CP, as in (46a), is complementizer drop possible.

While there is less overt syntactic evidence for the presence of *cP* in German and Icelandic as opposed to MSc, I have given indirect evidence in the form of complementizer drop data. In addition, the semantic differences between the predicate classes also hold, giving (somewhat weak) evidence for the effects of *cP*. However, I have shown that it is certainly plausible to extend the proposal to other Germanic languages. The hope is to find stronger evidence of the syntactic reality of *cP* in future research.

7. Summary

In this chapter I have presented an analysis of EV2 in Swedish that has wide implications for the analysis of sentential complementation. I have proposed that non-factive verbs are associated with extra syntactic structure, in the form of *cP* selected by this class of verbs. This extra structure facilitates EV2 in the presence of an overt complementizer. Factives, which do not select *cP*, do not allow EV2. In addition, I claimed that *cP* is headed by a semantic operator [OP], which is responsible for 'non-factive' interpretations of embedded CPs. I presented morphological and semantic evidence for the extra projection from Hungarian in the form of the pronominals *azt* and *úgy*, which I argue originate in *cP*.

I also discussed the question of what verb classes license EV2, meaning which verbs can select for the more articulated *cP* structure I propose. Reviewing the literature, it becomes clear that 'factivity' turns out to be the wrong notion in separating out the verbs that allow EV2 and the verbs that don't allow EV2. Instead, the notion of 'familiar' vs. 'novel' complements, in the sense of Hegarty 1992, which follows Cattell 1978, is

adopted. The factive vs. non-factive distinction is replaced by ‘Familiar Complement-taking Predicates’ (FCPs) vs. ‘Novel Complement-taking Predicates’ (NCPs).

Finally, I showed that the analysis of MSc EV2 can plausibly be extended to other Germanic languages, specifically German and Icelandic. In the next chapter, I extend the proposal to provide an analysis for factive islands.

Chapter 2 Appendix: Occupants of cP

While the main thrust of this dissertation is syntactic, semantics plays a strong motivational role. I propose that there is an operator in the head of cP that contributes to the semantic interpretation of embedded clauses. However, in the absence of any current semantic theory that integrates the many factors that seem to be involved (familiarity, context-sensitivity, modality, intensionality, presupposition, etc.), I will steer clear of any bold claims as to how the semantics of the proposed operator works. Instead, I will briefly discuss some of the possibilities for the kinds of animals that may inhabit cP, without making any commitments to any one idea.

Assuming vampires are fictional characters, (1a) is a false statement, and (1b) is therefore also strange. However, (1c) is fine, regardless of whether or not the speaker believes in vampires.

- (1) (a) #Vampires walk the earth
(b) #Anne resents that vampires walk the earth.
(c) Anne believes that vampires walk the earth.

I claim that there is an operator in the head of cP in is responsible for the felicity of (1c). The [OP] serves, roughly speaking, to “remove the speaker from responsibility for the truth content of the lower clause”. The idea of an operator associated with non-fixed truth-values is not new. Progovac 1994 argues for an operator in the head of CP.⁴¹ This operator is licensed in a clause whose truth-value is not set positively. In her analysis, the operator is needed to license a Negative Polarity Items (NPIs) in non-negative contexts, as in (2).

- (2) (a) I doubt [CP [C that **OP** [IP **anyone** has come.]]] (negative verb)
(b) [CP [C' Has **OP** [IP **anyone** come?]]] (Yes/no question)
(c) [CP [C' If **OP** [IP **anyone** comes]]], let me know. (Conditional)
(d) [NP Every man [CP who [C' has **OP** [IP read **anything** by Chomsky]]]]
will attend the lecture. (Universal Quantifier)
(e) [CP Had **OP** [IP **anyone** misbehaved], we would have left.]
(Counterfactual Conditional) (Progovac 1994:67)

⁴¹ See also Giannakidou 1998 for discussion of non-veridical operators.

Nichols (2001) also proposes an operator in non-factive contexts. She examines the syntax and semantics of propositional attitude reports, focusing on extraction facts. Adjunct extraction is allowed from under a non-factive predicate like *believe*, but not from under a factive like *regret* (3).

- (3) (a) How do you think that you behaved *t* ?
(b) *How do you regret that you behaved *t* ?

Nichols argues for the special status of non-factives as opposed to factives, and that there is an operator associated with non-factives that is not present under factives. She states:

A consideration of the semantic properties of the factivity classes in terms of the character of evaluation sets of worlds reveals that the factivity problem as currently stated (e.g. “Why is extraction blocked out of factive complements?”) has been conceptualized the wrong way around, essentially backwards.
(Nichols 2001:121)

In other words, it is not factives that are special, but non-factives (contra K&K). Nichols applies a dynamic conversational model of evaluation sets (Schlenker 1999, Giorgi & Pianesi 1997, Kratzer 1979, 1981, 1991) to the factivity problem. In this system, the truth-value of a proposition is evaluated with respect to some context. The context set can be added to as the conversation proceeds, and this revised context set is used to evaluate any new proposition. The *common ground* of a conversation is the set of all propositions that all participants share. The evaluation set of worlds of the common ground includes the actual world, so the evaluation set for any new proposition includes the actual world. Thought of in this way, having the actual world included in the evaluation set is the default. In order to construct a modal evaluation context, something new must be added.

Applied to the evaluation of subordinate sentential clauses, factives use the default evaluation context (with the actual world included), while non-factives are somehow special. As Nichols notes, this way of thinking is opposite from the traditional thought that it is factives that are somehow special, and in need of special account. Using the dynamic conversational model of evaluation sets, there is nothing special about the presuppositional behavior of factives – they are simply evaluated like factive main

clauses, with the actual world necessarily included in the evaluation set. Non-factive subordinate propositions, on the other hand, have an evaluation context that is special in relation to the common ground. With non-factives the actual world is not necessarily included in the evaluation set.

Nichols proposes that there is an assertive operator associated with non-factive verbs. The contribution of the operator is summarized briefly in (4).

- (4) (a) CPs have associated context variable sets $C \langle \text{speaker, (hearer), time, world} \rangle$ needed for interpretation (as in Schlenker 1999).
- (b) With the value $\langle +\text{current speaker} \rangle$, the actual world is necessarily included in the evaluation set (as in main clauses).
- (c) Factives do not supply a $\langle \text{speaker} \rangle$ value to the context variable set, so the default value is specified $\langle +\text{current speaker} \rangle$.
- (d) Non-factives are associated with an assertive operator, which may supply a different value for $\langle \text{speaker} \rangle$.

Nichols assigns no position in the syntax to the assertive operator.⁴² For her, the extraction asymmetry in (3) derives from semantic properties. Factive islands like (3b) are considered the norm; in other words, adjunct movement is not allowed in normal circumstances.⁴³ Only under the special condition in which the assertive operator is present, changing the $\langle \text{speaker} \rangle$ value in the evaluation set of the embedded clause, do we get an extension of the domain of movement. For Nichols, this is what allows adjunct movement in (3a) as opposed to (3b), where for her there is no domain extension.⁴⁴

Experiments by Jill de Villiers (1998) show that until the age of 3-4, children maintain the hypothesis that all embedded clauses are true. Until the acquisition of the ability to represent false complements, all complement clauses are treated as factive. She

⁴² Nichols (2001:Chapter 3) actually leaves open the possibility that the operator may be represented in the syntax, in the form of an event argument in attitude nominal constructions. I will discuss this further in Chapter 5.

⁴³ Nichols 2001 does not analyze cases of EV2 that are presented in this chapter, or cases of non-local NPI licensing which I present in chapter 4. These are two more cases in which syntactic differences appear to go along with the semantic differences in the predicate classes. I interpret these cases as evidence for the structural difference I proposed in (38) and (39) in chapter 2. I present an analysis of factive islands in Chapter 3 that relies on the presence of cP to allow adjunct extraction.

⁴⁴ Nichols account of factive islands is discussed in more detail in Chapter 3.

proposes that at age 3-4 children acquire a feature in CP that allows a complement clause to be false without affecting the overall truth of the sentence. de Villiers hypothesizes that this feature opens up ‘possible worlds’ with truth relativized to those worlds. This feature has a historical precedent in the ‘plugs’ of Karttunen (1973); de Cuba & Marušič (2003) follow Karttunen and propose a ‘plug operator’. In a possible worlds framework, a sentence does not need to be evaluated as true in the actual world in order for the sentence to be evaluated as true. The embedded clause need only be true in some possible world (someone else's, or a hypothetical world).

In the works mentioned in this appendix, something ‘extra’ is proposed to deal with the semantics of what we can loosely call ‘non-factivity’. They share the idea that there is extra semantic machinery (in the form of operators or features) associated with non-factive interpretations. These proposals are all different, and not necessarily compatible, but it is suggestive that they all conclude that non-factives are more complex semantically than factives. Unfortunately, while they all point in a similar direction, none of them stands alone as a complete semantic theory that can be easily integrated into the present work. However, they all hint at a similar conclusion, despite their variety of semantical perspectives.

Whatever the correct semantics of the operator or feature turns out to be, the main proposal of this dissertation (there is extra syntactic structure (*cP*) for what we loosely call non-factives) appears to be a promising match for the future. The extra syntactic structure I propose is a natural place to house any ‘non-factive’ operators or features. As I have argued, the presence or absence of *cP* correlates with the presence or absence of notions of semantic interpretation like familiarity, context-sensitivity, modality, intensionality, and presupposition. McCloskey 2005 uses the term ‘assertoric force’ to describe the semantic contribution of an extra syntactic position (a recursive CP) in embedded clauses, and Haegeman 2006 argues for a left-peripheral position for ‘speaker deixis’ which is not present for her in ‘reduced’ factive CPs. Again, ‘non-factivity’ is correlated with more complex syntactic structure. While we await a complete semantic theory of ‘non-factivity’, the syntactic account in this dissertation appears to be headed in the right direction.

Chapter 3: Faetive FCP Islands

1. Introduction

The focus of this chapter is to provide an analysis of factive islands, exploiting the core proposal of this dissertation, namely that there is extra syntactic structure associated with non-factive predicates, as opposed to factive predicates (contra Kiparsky & Kiparsky 1971, K&K henceforth). As discussed in Chapter 2, Cattell 1978 and Hegarty 1992 provide a better verb classification system than the classical ‘factive vs. non-factive’ distinction. The notion of ‘familiar vs. novel complements’ fits the class of predicates that allow Embedded Verb Second (EV2) much better than a factive vs. non-factive distinction. On the basis of the EV2 facts (among others) I argue in Chapter 2 that Class A ‘novel’ predicates select a more structurally complex sentential complements than Class B ‘familiar’ predicates, discarding the factive non-factive distinction. The lists from Hegarty’s (1992:13) classification are repeated in (1). I adopt a version his terminology, calling Class A predicates *Novel Complement taking Predicates* (NCPs) and Class B *Familiar Complement taking Predicates* (FCPs).⁴⁵

(1) **Class A: Novel Complement taking Predicates (NCPs):** believe, think, say, claim, assert, allege, declare, state, propose, suggest, assume, suppose, conjecture, suspect, consider, imagine, be likely, be possible

Class B: Familiar Complement taking Predicates (FCPs): notice, point out, realize, recognize, forget, admit, emphasize, regret, know, remember, conclude, confirm, verify, learn, find out, inform, agree, accept, insist, stress, hate, like, be aware, be significant, be odd, be glad, be proud

Another syntactic difference that has been frequently noted (and briefly mentioned in Chapter 2) is that complements to factive verbs are weak islands for extraction. Cattell 1978 shows that *why*-extraction is only possible out of what I am calling NCPs (1a), and not out of FCPs (1b). So, the terminology I will use henceforth for what have

⁴⁵ The NCPs class are all non-factive, while the FCP class contains all of the factives plus some non-factives. So, factives are a subset of FCPs.

traditionally been called ‘Factive Islands’ in the literature will be the more accurate ‘FCP Islands’. An example of an FCP Island is given in (2).

- (2) (a) How do you believe that you behaved?
 (b) *How do you regret that you behaved?

Extraction of the adjunct *how* is fine from the complement of the NCP *believe* in (2a), but is blocked from the complement of the FCP *regret* in (2b). Cattell (1978:61) gives similar data, with *why*-extraction, with NCP (3a) being ambiguous between the upper and lower reading of *why*, while in FCP (3b) only the upper reading is available.

- (3) (a) Why do the police believe that Sue killed Harry?
Can be questioning the reason for the believing, or for the killing
 (b) Why do the police regret that Sue killed Harry?
Can only be questioning the reason for the regretting, not the killing

To account for the asymmetries in (2) and (3), I argue that the extra layer of syntactic structure (*cP*) I have proposed for NCPs is responsible. Syntactically, the *cP* projection opens up an escape hatch for adjunct extraction from the sentential complements in (2a) and (3a), while the lack of a *cP* projection under FCPs like (2b) and (3b) leaves adjuncts stranded. The structures are given in (4) and (5).

(4) **Structure for Novel Complement taking Predicates (NCP)**

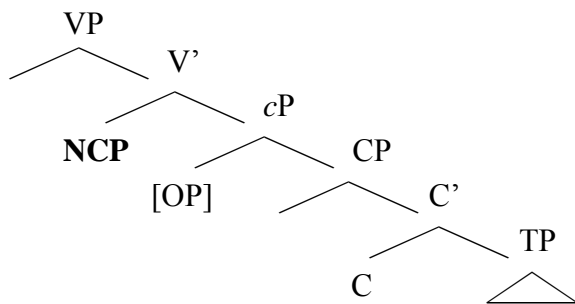

(5) **Structure for *Familiar Complement taking Predicates (FCP)***

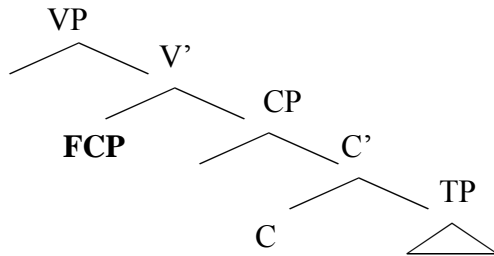

The details of how the extra structure in (4) allows for adjunct extraction will be discussed below.

The chapter will be organized as follows. The analysis presented here is greatly influenced by McCloskey 2005, so sections 2-3 briefly summarize the main arguments of that paper, setting up the following sections. Section 2 presents data on Irish English Subject Auxiliary Inversion (SAI) and adjunction in Standard English, and McCloskey’s “Adjunction Prohibition” is introduced. Section 3 makes the connection between the SAI facts and the Adjunction Prohibition, and McCloskey’s unified analysis of embedded SAI and adjunction is presented. In Section 4, I combine McCloskey’s analysis with the proposal in Chapter 2 to provide a solution for the FCP island puzzle. In Section 5, I apply the analysis to restrictions on adjunct movement and ordering in Serbian *wh*-movement. In Section 6, I review some previous accounts of factive islands and conclude that the present analysis is superior. Section 7 is a summary.

2. Subject Auxiliary Inversion and The Adjunction Prohibition

McCloskey 2005 shows that unlike in Standard English, Subject Auxiliary Inversion (SAI) is possible in Irish English polar questions (6) and *wh*-questions (7). However, as the examples in (8) show, SAI is not available under FCPs.⁴⁶

- (6) (a) I wondered was he illiterate. [IE]
 (b) I asked Jack was she in his class.
 (McCloskey 2005:2)

⁴⁶ Irish English examples are marked (IE), Standard English (SE).

- (7) (a) I wonder what is he like at all. [IE]
 (b) I asked him from what source could the reprisals come.
 (McCloskey 2005:2)
- (8) (a) *I found out how did they get into the building. [IE]
 (b) *The police discovered who had they beaten up.
 (c) *I remember clearly how many people did they arrest.
 (McCloskey 2005:3)

Examples (6) through (8) show that T-to-C movement is possible under *wonder* and *ask* type predicates, but ruled out under FCPs. It worth noting at this point that there is no presupposition of truth for the sentences embedded under *wonder/ask*, so in this way they pattern semantically with non-factives, and all NCPs are non-factive.

Another interesting case is observed with temporal adverbial adjunction. Jackendoff 1972 provides a classification of typically TP-adjoined temporal adverbs (*in general, most of the time, half the time, usually, next Christmas, every day, tomorrow, yesterday, in a few days, etc.*). This TP-adjunction is illustrated in (9). In addition, some (though not all) of these adverbs can adjoin to VP, as in (10).

- (9) [TP Usually/most of the time [TP I understand what he's talking about]]. [SE]
 (McCloskey 2005:6)
- (10) (a) I would [VP usually [VP go to Bundoran for my holidays]]. [SE]
 (b) *I will [VP next Christmas [VP go to Bundoran for my holidays]].
 (McCloskey 2005:6)

In embedded contexts like (11), the fact that the adverb appears to the right of the complementizer provides evidence that it is adjoined to TP. Adverbial clauses also appear between the complementizer and the subject, as in (12), suggesting adjunction to TP as well.

- (11) (a) It is probable that [TP in general/most of the time [TP he understands what is going on]]. [SE]
 (b) That [TP in general [TP he understands what is going on seems fairly clear]] .
 (McCloskey 2005:7)

- (12) (a) He promised that [TP when he got home [TP he would cook dinner for the children]]. [SE]
 (b) She swore that [TP after she finished her thesis [TP she would move to Paris]]. (McCloskey 2005:7)

In contrast, adverbs & adverbial clauses positioned to the left of the complementizer cannot be easily construed with material in the embedded CP, as in (13) and (14).⁴⁷

- (13) (a) *It is probable [CP in general/most of the time [CP that he understands what is going on.]] [SE]
 (b) *[CP In general [CP that he understands what is going on seems fairly clear]]. (McCloskey 2005:7)
- (14) (a) *He promised [CP when he got home [CP that he would cook dinner for the children]]. [SE]
 (b) *She swore [CP after she finished her thesis [CP that she would move to Paris]]. (McCloskey 2005:8)

These data show that adjunction to CP is not allowed.

The pattern in (15) through (17) emerges from the adjunction data in this section. Adjunction to the VP-complement of T and to the TP-complement of C are possible, while adjunction to the CP-complement of a lexical head is impossible, as indicated by the star on the structure in (17).

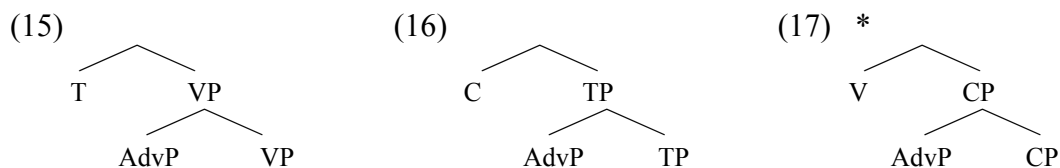

Given this pattern, McCloskey 2005, following Chomsky 1986, formulates the Adjunction Prohibition, given in (18).

⁴⁷ McCloskey (2005:8) notes that this may overstate the matter. For many speakers, it is not impossible to construe the adverbial with the lower clause. There will be more to say on this point once more of the proposal has been argued. See footnote 53 for further discussion.

- (18) The Adjunction Prohibition: Adjunction to a phrase which is s-selected by a lexical (open class) head is ungrammatical.

It is clearly not the case that CP-adjunction in general is ruled out. Adjunction is still possible when the CP is not selected by a lexical (open class) head. The adjuncts in (19) are all adjoined to what are clearly root CPs.

- (19) (a) [CP When you get home, [CP what do you want to do]]? [SE]
(b) [CP When you get home, [CP will you cook dinner for the kids]]?
(c) [CP Next Christmas [CP whose parents should we go to]]?
(d) [CP Most of the time [CP do you understand what's going on]]?
(e) [CP Next Christmas, [CP under no circumstances will I be willing to cook dinner]].
(f) [CP Most of the time, [CP when she is working on a paper, [CP only rarely does she leave her office]]]. (McCloskey 2005:10-11)

However, since these CPs are not lexically selected, they are not subject to the Adjunction Prohibition. I will say more about the role selection plays in Section 3.

3. Adjunction and Inversion – McCloskey's Connection

McCloskey 2005 makes a connection between the adjunction data and the inversion data presented in Section 2. First, he notes that apparent problems for the Adjunction Prohibition arise when we observe the relative well-formedness of the examples in (20)⁴⁸. In these cases, adjunction to CP seems to be fine⁴⁹.

- (20) (a) ?He asked me [CP when I got home [CP if I would cook dinner]]. [SE]
(b) ?I wonder [CP when we get home [CP what we should do]].
(McCloskey 2005:16)

⁴⁸ The judgments in (20) are from McCloskey; I find both sentences to be completely grammatical.

⁴⁹ Judgments on (20) and (21) are with the lower construal of the adverbial.

These sentences appear to be in direct violation of the Adjunction Prohibition, with adjunction to a lexically selected CP. However, the pattern in (20) is only possible in the complements of certain predicates. CP-adjunction is completely impossible under FCPs, as in (21).

- (21) (a) *It was amazing [_{CP} while they were out [_{CP} who had got in to their house]]. [SE]
 (b) *The police established [_{CP} while we were out [_{CP} who had broken in to our apartment]]. (McCloskey 2005:16)

Second, he notes that the contrast between (20) and (21) mirrors exactly the contrast observed earlier between the predicates which allow embedded T-to-C in polar and *wh*-questions (*wonder/ask*), as in (6) and (7), and those which do not (FCPs), as in (8).⁵⁰

- (6) (a) I wondered was he illiterate. [IE]
 (b) I asked Jack was she in his class. (McCloskey 2005:2)
- (7) (a) I wonder what is he like at all. [IE]
 (b) I asked him from what source could the reprisals come. (McCloskey 2005:2)
- (8) (a) *I found out how did they get into the building. [IE]
 (b) *The police discovered who had they beaten up.
 (c) *I remember clearly how many people did they arrest (McCloskey 2005:3)

Corresponding to the instances of embedded T-to-C in (6) and (7), we find instances of adjunction of adverbials to CP. For the *wonder/ask* class of matrix predicates, the results are either good or only marginally unacceptable in Standard English, as in (22). For the varieties that allow embedded T-to-C, the corresponding examples are completely grammatical, as in (23).

⁵⁰ Examples (6), (7) and (8) are repeated from Section 2.

- (22) (a) ?Ask your father [_{CP} when he gets home [_{CP} if he wants his dinner]]. [SE]
 (b) ?I was wondering [_{CP} next Christmas [_{CP} if he would come home]]. (McCloskey 2005:17)
- (23) (a) Ask your father [_{CP} when he gets home [_{CP} does he want his dinner]]. [IE]
 (b) I was wondering [_{CP} next Christmas [_{CP} would he come home]]. (McCloskey 2005:17)

However, FCPs, which completely disallow the option of adjunction of an adverbial phrase to their CP-complement, also completely disallow the option of embedded T-to-C.

- (24) (a) *It was amazing [_{CP} who did they invite]. [SE], [IE]
 (b) *The police established [_{CP} who had they beaten up]. (McCloskey 2005:17)

The contrast between the FCPs in (24) and the *wonder/ask* predicates in (22) is very robust for those speakers who allow embedded T-to-C, and is also clearly detectable for speakers of the ‘standard’ variety.

The examples presented so far in this section show that there is a clear pattern between adjunction on the one hand, and SAI on the other. Under *wonder/ask* predicates, both CP-adjunction and SAI are allowed, while under FCPs both CP-adjunction and SAI are prohibited. Given this pattern, an explanation for why adjunction to an embedded CP is possible (and by analogy, why embedded SAI is possible) is needed if we are to maintain the Adjunction Prohibition as a generalization.

To solve the problem of the apparent cases of adjunction to a lexically selected CP, McCloskey proposes that both adjunction to CP (as in (22) and (23)) and SAI (as in (6) and (7)) are possible under *wonder/ask* type predicates because they select a recursive CP structure. Since CP₂ is not lexically selected by the verb *wonder* in (25), it is not subject to the Adjunction Prohibition.

(25) I wonder what should we do.

[IE]

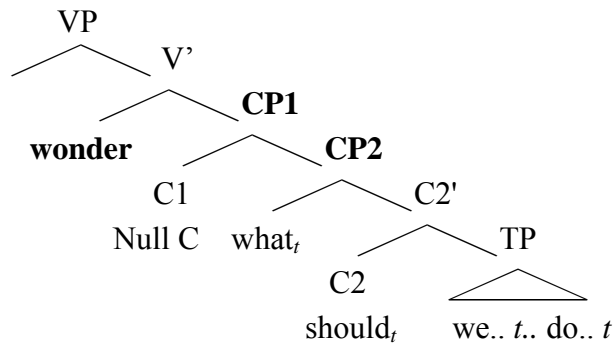

(McCloskey 2005:20)

Following the Adjunction Prohibition, which allows adjunction to a non-lexically selected phrase, the grammaticality of (20), (22) and (23) is now explained. In all these cases, the structure of the *wonder/ask* predicate is as in (25), leaving the lower CP open to adjunction. The grammatical examples of SAI in (6), (7) and (23) receive a similar analysis, to be spelled out below.

McCloskey 2005 argues that both head movement to C and adjunction to CP affect selection. In other words, selection is context sensitive. In the case where a lexical head (the verb in the cases we have been looking at) directly selects a CP, adjunction to that CP or head movement of a lower verb to the head of that CP will change its nature, so the selecting verb will not recognize the CP and selection will fail.

In the adjunction cases, adjunction of A to B, where B has the label K, creates a syntactic object whose label consists of the ordered pair $\langle K, K \rangle$, as in (26).⁵¹

(26) $\{ \langle K, K \rangle, \{ A, B \} \}$

For example, adjunction of an AP to a CP headed by *that* will, on this view, create the syntactic object in (27).

⁵¹ McCloskey's analysis, and mine to follow, crucially make a formal distinction between specification and adjunction, following the Bare Phrase Structure ideas of Chomsky 1995a. Thus, both of our proposals run counter to the antisymmetry proposal of Kayne 1994, where specifiers and adjuncts are the same (specifiers are adjuncts).

(27) {<that , that>, { AP, CP } }

The label in such cases is a pair rather than a singleton, and is therefore not what the lexical head is subcategorized to select. Thus, the syntactic object formed in (27) does not satisfy the L-selectional feature borne by the selecting lexical head.

The examples with SAI receive a similar analysis. If particular verbs, adjectives or nouns L-select particular complementizers, then head movement into those C-positions will give rise to violations of L-selectional requirements. In other words, head movement changes the nature of the element being selected. In the ungrammatical examples under FCP predicates in (8) and (24), T-to-C movement changes the CP into something the selecting predicate does not recognize, so the derivation crashes. However, in the grammatical examples of SAI in (6), (7) and (23), the embedded CP is selected by the functional head C1 and CP1 is legitimately selected by the lexical verb. This analysis follows from the structure in (25) versus the FCP structure in (5), repeated here from Section 1.

(5) **Structure for *Familiar Complement taking Predicates (FCP)***

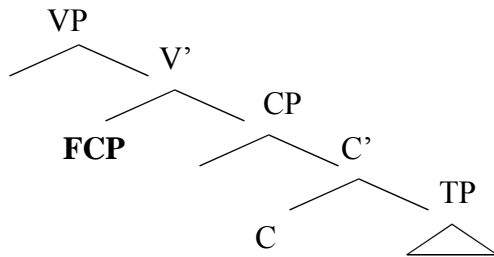

At this point, similarities between McCloskey's structure for *wonder/ask* predicates in (25) and my proposed structure for NCP predicates in (4), also repeated here from Section 1, should be immediately apparent.

(4) **Structure for *Novel Complement taking Predicates (NCP)***

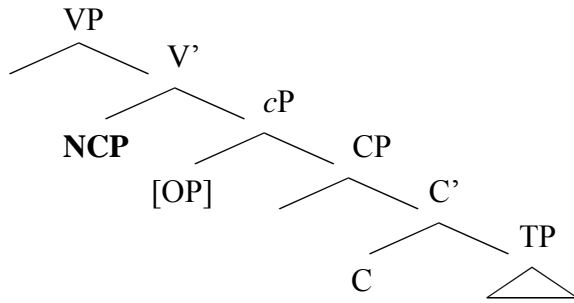

In both cases a CP is selected by a functional head (C1 for McCloskey, *c* for me), as opposed to a lexical head (FCP). From this point I will assume the McCloskey structure for *wonder/ask* predicates like (25) to be subsumed under my NCP structure in (4).⁵² Evidence for the similarity of *wonder/ask* predicates and NCPs comes from another variety of English. McCloskey, citing Henry 1995, presents data from Belfast English (BE), where T-to-C takes place in the complement of a NCP triggered by WH movement, as in (28).

- (28) (a) They wouldn't say which candidate they thought [_{CP} should we hire] [BE]
 (b) I'm not sure which one I think [_{CP} should we buy].
 (McCloskey 2005:40)

Here we see SAI taking place under the NCP *think*, just as we have seen it under *wonder/ask* predicates in the Irish English examples in (6), (7) and (23)⁵³.

The Belfast English data in (28) is reminiscent of restrictions on EV2 in Mainland Scandinavian from Chapter 2, where EV2 (which is optional) is allowed under NCPs, but not under FCPs, as illustrated in (29).

⁵² Marcel den Dikken (p.c.) points out that in McCloskey's structure in (25), CP2 is not selectable by the matrix clause in this structural environment. This would seem to flout the verb's selectional restrictions, unless the interrogativity of CP2 is somehow visible on CP1. This kind of problem does not arise on the present proposal – the [OP] of *c*Ps in the complement of verbs like *wonder* can be endowed with a Q-feature, [Q-OP].

⁵³ Returning to the discussion in footnote 47, the fact that some speakers accept the lower construal of the adverbials in (13) and (14) is probably due to the fact that the CPs in these examples are associated with NCPs (none of the CPs are presupposed), which allow CP-adjunction. If this is the case, then the degraded status of these examples for many speakers must arise for independent reasons.

- (29) (a) *Rickard ångrade att han var inte hemma [Swe]
Rickard regretted that he was not home
 ‘Rickard regretted that he was not home.’
 (b) Rickard sa att han var inte hemma
Rickard said that he was not home
 ‘Rickard said that he was not home.’

EV2 in Mainland Scandinavian has also been widely analyzed as involving CP-recursion (see Vikner 1995, Holmberg & Platzack 1995, Iatridou & Kroch 1992, and de Cuba 2002, 2006, among others). The two CP layers are needed to account for EV2 movement (analyzed as involving verb movement to the C head, and XP movement to Spec CP) in the presence of an overt complementizer (analyzed as residing in the head of the higher CP in the recursive structure).

4. FCP Islands and the Adjunction Prohibition

Given the background of the Adjunction Prohibition provided in sections 2 and 3, we can now return to the main topic of the chapter, FCP islands. (30) shows that argument extraction is fine under both FCPs & NCPs, while (31) shows the adjunct extraction asymmetry between NCPs and FCPs. I repeat the basic structures I have proposed for NCPs (4) versus FCPs (5).

- (30) (a) Who do you regret that John saw *t* ?
 (b) Who do you think that John saw *t* ?
 (31) (a) How do you believe that you behaved *t* ?
 (b) *How do you regret that you behaved *t* ?

(4) **Structure for *Novel Complement taking Predicates (NCP)***

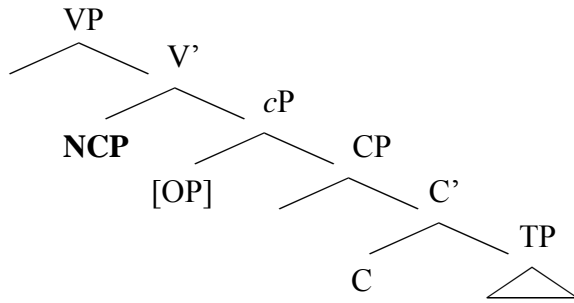

(5) **Structure for *Familiar Complement taking Predicates (FCP)***

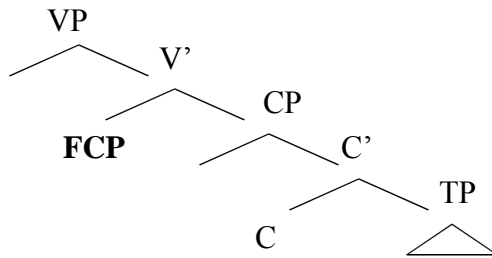

Examples (28) and (29) give strong evidence that NCPs pattern with questions in allowing CP-recursion, as in (4).⁵⁴ This points to a solution for the FCP island problem, namely a way to have a difference between argument extraction and adjunct extraction. I propose that adjuncts and arguments move through different positions.

- (32) (a) *Arguments*: proceed up the tree through Spec CP
 (b) *Adjuncts*: proceed up the tree by adjunction to CP

⁵⁴ McCloskey (2005:23) provides sentences like (i), which have two instances of *that*, as more evidence for CP-recursion in embedded clauses.

- (i) He thinks that if you are in a bilingual classroom that you will not be encouraged to learn English.

In addition, as reported in Haegeman (2006:1666), McCloskey (2004:handout p. 17, ex. (83b)) shows that double *that* structures are not routinely available in the complements of factive verbs, as in (ii).

- (ii) *They regretted that especially since it was raining so heavily that they hadn't left earlier.

In addition, Antieau (2003:398,399) reports on an informant in a Colorado Plains English corpus who regularly allows double complementizers, as in (iii) and (iv).

- (iii) One time a guy from Arkansas or Kentucky asked me if that what kinds of peas those were.

- (iv) So if that they do wear leather gloves they usually wear cloth underneath them.

I take this as more evidence supporting the idea that a complementizer can appear in little *c* as well as C.

Given the assumptions in (32), the proposed structures in (4) and (5) give us a solution to the FCP island problem. In the argument extraction examples in (30), both sentences are fine because Spec CP is an available landing site in both NCP (4) and FCP (5) contexts. However, adjunction to CP is impossible in the FCP structure in (5), given the Adjunction Prohibition. This is illustrated in (33) and (34).

- (33) (a) $[_{VP} \text{believe } [_{cP} \text{ } [_{CP} \dots]]]$
 (b) $[_{VP} \text{regret } [_{CP} \dots]]$
- (34) (a) How do you believe $[_{cP} \text{ } [_{CP} \text{t}_{how} \text{ } [_{CP} \text{that you behaved}]]]$?
 (b) How do you regret $[_{*cP} \text{ } [_{CP} \text{t}_{how} \text{ } [_{CP} \text{that you behaved}]]]$?

The adjunct *how* in (34b) is left with no escape hatch from the embedded clause (due to the Adjunction Prohibition). In (34a) however, the lower CP is not lexically selected (see (4)), leaving it open for adjunction of *how* to CP, and thus an escape hatch for further movement. As discussed in Section 3.2 of Chapter 2, when *c* merges with CP, the phase-edge of CP is widened to include both the edge of CP and the edge of *cP*. CP maintains its phase-edge status, leaving C, SpecCP, and adjunctions to CP available for further syntactic operations despite the presence of *cP*. In addition, *cP* bears no [+EPP] feature, so no specifier projects from *cP*. Since *cP* and CP together constitute one widened phase-edge for me, there is no stop in *cP* necessary to for adjuncts or arguments to escape to the higher clause. Both move through CP (by Spec CP of adjunction to CP) and skip *cP* on their way up.

In this section I have provided a novel analysis of the factive island problem. In the next section I apply this analysis to Serbian factive islands, and show that my account is also useful in accounting for other adjunct extraction restrictions in Serbian.

5. Adjunct Movement Restrictions in Serbian

In this section I examine restrictions on adjunct movement in the Serbian variety of Serbo-Croatian (SSC).⁵⁵ First, we see that FCP islands are also found in Serbian, as illustrated in (35).^{56,57}

- (35) (a) Zašto tvrdiš [da si Nenadu dao knjigu *t*]? [SSC]
why claim-2sg that AUX to-Nenad given a book
 ‘Why do you claim that Nenad was given a book’
 (b) *Zašto žališ [što si Nenadu dao knjigu *t*]?
why regret-2sg that AUX to-Nenad given a book
 ‘Why do you regret that Nenad was given a book’

The restriction in (35) is a familiar one, mirroring the FCP island data from English in (3) and (31). The analysis in this chapter transfers smoothly to the SC facts, with the identical structures in English (33), repeated here, and SC (36). I apply the structure in (36) to the sentences in (35), giving us (37).

- (33) (a) [VP believe [_{CP} [CP ...]]]
 (b) [VP regret [CP ...]]
- (36) (a) [VP tvrdiš [_{CP} [CP ...]]] [SSC]
claim
 (b) [VP žališ [CP ...]]
regret
- (37) (b) Zašto tvrdiš [_{CP} [_{CP} *t*_{zašto} [_{CP} da si Nenadu dao knjigu]]]?
why claim-2sg that AUX to-Nenad given a book
 (a) *Zašto žališ [*_{CP} *t*_{zašto} [_{CP} što si Nenadu dao knjigu]]]? [SSC]
why regret-2sg that AUX to-Nenad given a book

⁵⁵ This section is based on joint work with Ivana Mitrović.

⁵⁶ It is crucial to note that in all of the following examples, the judgments given are with the adjunct *zašto* (*why*) construed with the embedded predicate, not the matrix predicate.

⁵⁷ Note that when discussing data, we use ‘Serbian/Serbo-Croatian’ (SSC) for data we present, and ‘Serbo-Croatian’ (SC) for data presented in other papers. We use ‘Serbian’ because all of our native informants are from Novi Sad, Serbia, and we suspect there are regional dialectal differences. Unfortunately, we must leave a much-needed comprehensive study of other varieties of Serbo-Croatian to future research.

Adjunct extraction in (36b) is ruled out because CP is lexically selected by the FCP *žališ*, ruling out adjunction to CP and leaving the adjunct with no escape hatch. Adjunct extraction in (36a) is fine, given that the NCP *tvrdiš* does not lexically select CP, making adjunction to CP possible, allowing the adjunct *zašto* to reach the edge of the phase and then move out.

In addition to the restriction against adjunct extraction from FCPs, there are ordering restrictions on the adjuncts that are extracted from NCP complements. As illustrated in (38), in a long-distance Multiple *Wh*-Movement (MWM) construction, a *wh*-adjunct must appear to the left of a *wh*-argument.⁵⁸

- (38) (a) Zašto koga tvrdiš [da je Marko istukao *t t*]? [SSC]
why whom claim-2sg that AUX Marko beaten
 ‘Why do you claim that Marko has beaten whom?’
 (b) *Koga zašto tvrdiš [da je Marko istukao *t t*]?

This is in contrast to MWM in matrix questions, where the Superiority Condition is violated and any *wh*-word order is allowed, as in (39). This ordering freedom holds for adjuncts like *zašto* (*why*), which in (39) can appear in the first, second or third position among *wh*-words.

⁵⁸ Note that our informants either found both orders in examples like those in (38) ungrammatical (4 out of 9), or they accepted (38a) with the *wh*-adjunct preceding *wh*-argument and rejected (38b) with *wh*-argument preceding *wh*-adjunct (5 out of 9). In the variety of Serbo-Croatian reported in Bošković (1997a:6), the opposite judgments hold. In addition, Nadira Aljović (p.c.) reports that in her variety, long-distance argument movement and long distance adjunct movement, while independently available, are incompatible in the same sentence. For her, (38a) and (38b) are both out, as in both cases an argument and an adjunct move long-distance in the same sentence. At the moment we have no explanation for these facts. We unfortunately must restrict ourselves here to a discussion of the Novi Sad variety here, and again leave important microvariation work to the future.

- (39) (a) Ko je koga zašto istukao? [SC]
who AUX whom why beaten
 'Who beat whom why?'
 (b) Ko je zašto koga istukao?
 (c) Koga je ko zašto istukao?
 (d) Koga je zašto ko istukao?
 (e) Zašto je ko koga istukao?
 (f) Zašto je koga ko istukao?

I argue that the analysis of FCP islands in this chapter, in addition to capturing the restriction on adjunct extraction from Serbian FCPs as in (35), can also capture the restrictions on adjunct movement in (37), without losing the benefits of previous analyses of MWM in matrix questions (38), such as Bošković 1997a, 1998, 2003.

Rudin 1988a proposes that there are two types of MWM languages, the Bulgarian-type in (40), and the Serbo-Croatian-type in (41).

- (40) (a) [_{CP} Koj kogo [_{IP} *vižda?*]] [Bulg]
who whom sees
 'Who sees whom?'
 (b) *_{CP} Kogo koj [_{IP} *vižda?*]] (Stjepanović 2003:3)
- (41) (a) [_{CP} Ko [_{IP} koga *vidi?*]] [SC]
who whom sees
 'Who sees whom?'
 (b) [_{CP} Koga [_{IP} ko [*vidi?*]]] (Stjepanović 2003:3)

In Bulgarian-type languages, all *wh*-words are fronted to SpecCP, as in (40a). In addition, the Superiority Condition is obeyed, ruling out (40b). In SC-type languages on the other hand, only the first *wh*-word moves to SpecCP, and the rest are adjoined to IP, as in (41a). As was also illustrated in (39), the Superiority Condition is violated in (41b).

Bošković 1997a, 1998, 2003, and Stjepanović 1998, 2003 argue that in SC matrix MWM, *wh*-movement is adjunction to TP as opposed to movement to CP. This movement is not driven by a [+wh] feature, but by focus.⁵⁹ Bošković 1998 argues that

⁵⁹ See also den Dikken and Giannakidou 2002 for a discussion of *wh*-movement as movement to either CP or FocP depending on the type of construction.

focus movement is insensitive to Superiority because the movement is driven by a strong feature on *wh*-words, not by a strong feature on the target (as in *wh*-movement). Therefore, there are no economy violations for different orders of focus movement (there are no ‘shorter’ moves to get all of the *wh*-words up). This is in contrast to *wh*-movement to CP, driven by a [+wh] feature, which can be satisfied with a shorter move (the closest *wh*-phrase). The free ordering in (39) thus results from focus movement.

Bošković 1997a, 1998, 2003 argues that in SC MWM, Superiority effects arise whenever C is overt. This can be observed in long-distance questions (42), embedded question contexts (43), & matrix questions with an overt C (44).

- (42) (a) Ko koga tvrdiš [da je istukao?] [SC]
who whom claim-you that AUX beaten
 ‘Who do you claim beat whom?’
 (b) *Koga ko tvrdiš [da je istukao?] (Bošković 1997:5)⁶⁰
- (43) (a) Ima ko šta da ti proda. [SC]
has who what that you sells
 ‘There is someone who can sell you something.’
 (b) *Ima šta ko da ti proda. (Stjepanović 2003:4, citing Bošković)
- (44) (a) Ko li šta kupuje? [SC]
who C what buys
 ‘Who on earth buys what?’
 (b) *Šta li ko kupuje? (Stjepanović 2003:4, citing Bošković)

Bošković argues that SC is like French, which has *wh*-in-situ. This *wh*-in-situ is only mandatory under certain conditions, namely when C is overt. In (42) and (43), the complementizer *da* shows that C is overt, as does the complementizer *li* in (44). Thus, SC only obeys Superiority in conditions where French would have obligatory *wh*-movement. While a Bošković style analysis accounts well for the superiority facts above, it does not cover the restrictions on adjuncts in (35) and (38). I have shown how my analysis easily

⁶⁰ The judgments in (42) do not hold for the native informants we consulted. Our informants either did not accept long-distance MWM at all, or accepted both (42a) and (42b) as grammatical. For those who do accept long-distance MWM, the inverted order of *wh*-words it is just a matter of different focus. We leave this case of microvariation to future research.

accounts for the FCP island case in (35). I now turn to the restriction on adjunct ordering in long-distance MWM.

As shown in (38), repeated here, a *wh*-adjunct must appear to the left of a *wh*-argument. Further examples with different adjuncts are given in (45) and (46).

- (38) (a) Zašto koga tvrdiš [da je Marko istukao *t t*]? [SSC]
why whom claim-2sg that AUX Marko beaten
 ‘Why do you claim that Marko has beaten whom?’
 (b) *Koga zašto tvrdiš [da je Marko istukao *t t*]?
- (45) (a) Kada koga misliš [da je Marko istukao *t t*]? [SSC]
when whom think-2sg that AUX Marko beaten
 ‘When do you think that Marko has beaten whom?’
 (b) *Koga kada misliš [da je Marko istukao *t t*]?
- (46) (a) Gdje ste ko tvrdili [da je zaspao]? [SSC]
where are who claimed that AUX fallen-asleep
 ‘Who did you claim fell asleep where?’
 (b) *Ko ste gdje tvrdili [da je zaspao]?

Following the analysis laid out in this chapter, CP-Adjunction is possible in embedded clauses only when *cP* is present between V & CP (due to the Adjunction Prohibition). If all *wh*-words must move through the CP-field in long-distance *wh*-movement to escape the phase, then one would expect a *wh*-adjunct adjoined to CP to appear to the left of a *wh*-argument in SpecCP. So, the order in (47) is predicted. This prediction is borne out in (38), (45) and (46). The structure of (38) is given in (48).

(47) *wh*-Adjunct > *wh*-Argument

- (48) [_{CP}adjoined *Zašto* [_{CP} *koga* [_{VP} *tvrdiš* [_{cP} [_{CP}adjoined *t* [_{SpecCP} *t* [_C *da*] je Marko istukao]]]]] [SSC]
why whom claim-2sg t_{why} t_{whom} that AUX
Marko beaten

We see that the adjunct *zašto* (*why*) is adjoined to the embedded CP, and is then able to escape and move to the matrix CP. The argument *koga* (*whom*) moves through the Spec of the embedded CP on its way to the matrix Spec of CP. In both cases, the adjunct is in a higher position than the argument.

An explanation for the fact that long-moved arguments and long-moved adjuncts should maintain their relative order from their embedded escape-hatch positions to their position in the matrix clause comes from Müller & Sternefeld 1993. They propose the ‘Principle of Unambiguous Binding’ (PUB) in (49).

- (49) Principle of Unambiguous Binding: A variable that is α -bound must be β -free in the domain of the head of its chain (where α and β refer to different types of positions). (Müller & Sternefeld 1993:461)

Müller & Sternefeld claim that *wh*-movement proceeds through SpecCP, while scrambling proceeds through adjunction. They show that *wh*-movement may not feed scrambling, and scrambling may not feed *wh*-movement. This follows from the PUB, as movement to one of these types of positions precludes using another type of position as an escape-hatch. If the PUB is a true principle, then the consistent ordering of arguments vs. adjuncts from the embedded escape-hatch to the matrix CP follows; adjuncts must always move through/to adjunction positions, and arguments through/to SpecCP. This means that in a Bošković/ Stjepanović-style system, a moved *wh*-word could not first move to an IP-adjoined position and then move to SpecCP to escape the embedded clause. In addition, it rules out a *wh*-argument from moving to an IP-adjoined focus position in the matrix clause.

I assume that adjuncts will always proceed up the tree by adjunction, so I also need to prevent a *wh*-adjunct from moving from a CP-adjoined position in the embedded clause to an adjoined IP-adjoined focus position in the matrix clause. If a Bošković/Stjepanović-style analysis of short MWM is correct in assuming short MWM is focus movement and not *wh*-movement, then we would not expect that long-MWM would move to a matrix focus position. In true *wh*-movement, the *wh*-words move to CP

positions to check a [+wh] feature, unlike if focus movement. Even if a *wh*-adjunct did move to a matrix IP-adjoined position (and without a focus feature it has no reason to), it would still need to move on to the matrix CP to check its *wh*-feature.

The ‘adjunct on top’ pattern remains consistent if we add another *wh*-argument for long distance extraction. Only (50a) and (50b), with the adjunct in the leftmost position, are grammatical.

- (50) (a) Zašto ko koga tvrdiš [da je istukao]? [SSC]
why who whom claim-2sg that AUX beaten
 (b) Zašto koga ko tvrdiš [da je istukao]?
 (c) *Ko koga zašto tvrdiš [da je istukao]?
 (d) *Ko zašto koga tvrdiš [da je istukao]?
 (e) *Koga ko zašto tvrdiš [da je istukao]?
 (f) *Koga zašto ko tvrdiš [da je istukao]?

I adopt a multiple SpecCP analysis to explain the availability of two argument positions in (50a). I claim that all *wh*-arguments must move to/through SpecCP positions when undergoing ‘true’ *wh*-movement. Adjunction to a CP will still put the *wh*-adjunct in the highest position, above any/all specifier positions. (50c) through (50f) are therefore ruled out. (50b) shows that the ordering of arguments is free, as long as the adjunct is on top.

The question of how Bulgarian long-distance MWM works now arises. In cases parallel to SC (38), Bulgarian exhibits the opposite ordering of *wh*-adjunct and *wh*-argument. The grammatical order in (51) has the argument higher than the adjunct, while ungrammatical (52) has the adjunct higher than the argument. The orders are schematized in (53).

- (51) Koj kâde misliš [če e otišâl]? [Bulg]
who where think-2sg that has gone
 "Who do you think (that) went where?" (Rudin 1988b:7)
- (52) *Kâde koj misliš [če e otišâl]? [Bulg]
where who think-2sg that has gone
 "Who do you think (that) went where?"

(53) Adjunct/Argument ordering in long distance MWM

SC: *wh-Adjunct > wh-Argument, *wh-Argument > wh-Adjunct*
Bulgarian: **wh-Adjunct > wh-Argument, wh-Argument > wh-Adjunct*

Given my analysis of the SC ordering, the opposite Bulgarian pattern is in need of an explanation. In matrix MWM, Bulgarian also displays the *wh-Argument > wh-Adjunct* ordering, as in (54).

- (54) (a) Kogo kak e tselunal? [Bulg]
who how is kissed
'Who did he kiss how?'
- (b) *Kak kogo e tselunal?
how who is kissed
'Who did he kiss how?' (Stjepanović 2003:18)

Rudin 1988a and Bošković 1997b, 1998, 2002 argue that Bulgarian MWM involves the highest *wh*-word moving to SpecCP, and subsequent *wh*-word adjoining to the right of SpecCP. Bošković 1999 argues that in Bulgarian, C is also the position for focus movement (unlike SC, in which he argues the focus position is IP). This accounts for the Bulgarian Superiority effects shown in (40) and (54). If this is correct, then my account is fully compatible with the facts. I analyze all adjunct movement as proceeding through adjunction. If the *wh*-adjunction position is to the right in Bulgarian, then we would expect *wh*-adjuncts to always follow the first *wh*-argument in CP. We also might expect that in a case three *wh*-words, the order of the second two words would be free, given that only the first *wh*-word is in specCP, and the other two are adjoined. This is in fact the case, as we see in (55).

- (55) (a) Koj kogo kak e tselunal? [Bulg]
who whom how is kissed
'Who kissed whom how?'
- (b) Koj kak kogo e tselunal?
who how whom is kissed
- (c) *Kogo kak koj e tselunal?
whom how who is kissed (Stjepanović 2003:18)

6. Previous Analyses of Factive Islands

6.1. Rizzi 1990, Cinque 1990, Melvold 1986

Factive Islands fall outside of the Rizzi 1990 Relativized Minimality system, as there are no obvious intervening A' governors for the adjunct trace.^{61,62} For these cases, Rizzi assumes the analysis of K&K, where the sentential complement is immediately dominated by an NP node, protecting it from direct selection from the verb. In (56) I provide structures for a Rizzi style analysis.

- (56) (a) Non-factive Complementation (b) Factive Complementation

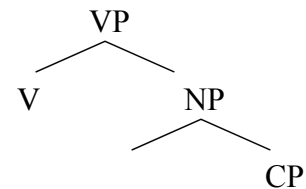
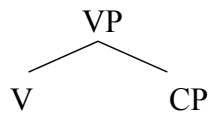

Since a factive complement is not directly selected by a lexical verb, it is a barrier for government. Rizzi gives the definition for a barrier in (57), which he adapts from Cinque 1990.

- (57) XP is a barrier if it is not directly selected by an X⁰ not distinct from [+V].

For Rizzi, adjunct extraction is blocked out of factive complements because the adverbial needs a chain of antecedent-governed relations, and as a barrier, the boundary of a factive complement fatally blocks antecedent-government relations.

Cinque 1990 provides a similar style analysis to Rizzi, also in the spirit of K&K. For Cinque, strong islands are sentential constituents that bear no lexical thematic relation to the predicate (not 'L-marked'), while weak islands do bear a lexical thematic

⁶¹ As Rizzi (1990:112) notes, this is also the case for sentential subjects, sentential complements of nouns, and adverbial clauses.

⁶² But see below for a discussion of Melvold's 1986 'factive operator', which does capture factive islands in a Rizzian system.

role, and can therefore permit some types of extraction.⁶³ Both factive complements (weak islands) and non-factive complements (non islands) receive a theta role, but they differ in the structural configuration under which the theta role is assigned. The complements of non-factive predicates are directly selected (58a), while the complements of factive predicates are sisters to V' (58b), as opposed to V.

(58) (a) Non-factive Complementation (b) Factive Complementation

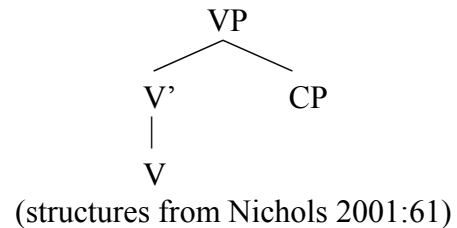
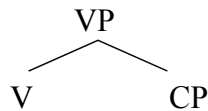

Cinque argues that a maximal projection not directly theta-marked by V is a barrier for government, giving an explanation for factive islands.

Melvold 1986 proposes a factive operator (an ‘iota operator’) in the Spec of CP, licensed by a [+definite] functional element. She argues that movement of an object NP past this operator results in a mild subjacency violation, but moving an adjunct past it results in a fatal ECP violation. The addition of this operator captures the weak islandhood of factives in a Rizgian system without the need to postulate different structures for factive vs. non-factive complements. Both L-mark their complements (both are sisters to their CP-complements). However, a factive operator analysis is not tenable given the view of factivity adopted in the present work. As discussed in Chapter 1 and subsequently, I argue that factivity is not the special case – non-factives are in need of special explanation, given that matrix clauses, adjuncts and relative clauses all behave like factive complements (they all include the actual world in their respective evaluation set of worlds). As de Villiers 1998 shows, the ability to recognize falsity in embedded clauses is acquired after sentential complementation (interpreted factively) is already in place. If there were a factive operator, we might also expect to find it in matrix clauses,

⁶³ The discussion of Cinque 1990 in this section is based on Nichols (2001:60-2).

adjuncts and relative clauses as well, given their factive interpretations. If a factive operator were in SpecCP in matrix clauses, a factive operator would rule out all *wh*-movement in Melvold's system. As Spec CP is filled, even arguments would be blocked. In her system arguments skip SpecCP as a landing site on their way out of factive complements, but this would not be possible in a matrix clause, as SpecCP is the final landing site for *wh*-words.

With the advent of the Minimalist Program (Chomsky 1995b), the notions of 'government' and 'barrier' have been removed from the tool box so to speak, leaving unclear how to translate the government-based analyses of Factive Islands provided by Rizzi 1990 and Cinque 1990 into current terms. In addition, Nichols (2001:62) provides semantic arguments against a Cinque-style account. First, there seems to be no principled reason why factivity should be associated with indirect theta-marking and non-factives with direct theta-marking. In a Rizzi or K&K style account, the presupposition is located in the NP, but it is unclear where the semantic presupposition (or lack of presupposition) resides in Cinque's system, or why it should be associated with one syntactic structure or the other.

In contrast to these previous accounts, the analysis of Factive Islands (FCP Islands in my terms) presented in this chapter does not rely on government or intrinsic barriers to block adjunct movement. Adjunct movement out of FCP complements is ruled out by the Adjunction Prohibition in (18), relying on constraints on lexical selection as opposed to government or barriers. Additionally, the structural difference between FCPs and NCPs that I propose is closely tied to the semantic differences between the classes in a principled and explanatory way. In other words, the structures I provide are well motivated on both syntactic and semantic grounds, and are compatible with current versions of the Minimalist Program.

6.2. *Nichols 2001*

Unlike K&K, Rizzi 1990 and Cinque 1990 (KKRC henceforth), whose solutions for the Factive Island problem rely heavily on syntactic structures to account for the unavailability of adjunct extraction, Nichols 2001 presents a purely semantic account. Nichols applies a dynamic conversational model of evaluation sets (Schlenker 1999,

Giorgi & Pianesi 1997, Kratzer 1979, 1981, 1991) to the factivity problem. In this system, the truth-value of a proposition is evaluated with respect to some context. The context set can be added to as the conversation proceeds, and this revised context set is used to evaluate any new proposition. The *common ground* of a conversation is the set of all propositions that all participants share. The evaluation set of worlds of the common ground includes the actual world, so the evaluation set for any new proposition includes the actual world. Thought of in this way, having the actual world included in the evaluation set is the default. In order to construct a modal evaluation context, something new must be added.

Applied to the evaluation of subordinate clauses, factives use the default evaluation context (with the actual world included), while non-factives are somehow special. As Nichols notes, this way of thinking is opposite from the traditional thought that it is factives that are special, and in need of special account. Using the dynamic conversational model of evaluation sets, there is nothing special about the presuppositional behavior of factives – they are simply evaluated like factive main clauses, with the actual world necessarily included in the evaluation set. Non-factive subordinate propositions, on the other hand, have an evaluation context that is special in relation to the common ground. With non-factives the actual world is not necessarily included in the evaluation set.

With the above discussion in mind, Nichols argues that the unavailability of adjunct movement out of factive complements should be considered the default case. In other words, it is the normal state of affairs that adjuncts cannot move out of complement clauses. Only under some special semantic conditions can adjunct extraction take place. Her assumptions concerning adjunct movement are given in (59).

- (59) (a) An adjunct *wh*-element *E* is ordinarily unable to move out of a clause.
(b) An adjunct *wh*-element *E* may move past a syntactic clause boundary only under certain semantic conditions. (Nichols, 2001:128)

Nichols argues that just as in factive main clauses, factive complements are evaluated by the default – the conversational common ground plus any propositions added in the course of the conversation. Therefore, it can be said that the context set for factive

complements is specified locally, within the complement clause itself (and as factive main clauses). In contrast, the evaluation set of non-factive complements is not specified from within the complement clause itself, but by the prepositional attitude predicate that selects the complement. Nichols thus characterizes the evaluation set for these complement clauses as non-locally specified. She summarizes the specification of evaluation sets for complement propositions in (60).

- (60) (a) The evaluation set for a proposition in a factive complement is specified locally.
 (b) The evaluation set for a proposition in a non-factive complement is specified non-locally. (Nichols, 2001:130)

Following (60), adjunct *wh*-movement out of a clause is typically not allowed unless there is some special semantic condition. This special condition is found in (60b), which sets non-factives apart as special. The normal case is for the evaluation set of a clause to be specified locally (by default), and in the normal case adjunct *wh*-movement out of a clause is bad, as in (61a). However, when we have the special case of an evaluation set being specified non-locally (by the selecting attitude predicate), adjunct *wh*-movement out of a clause becomes possible, as in (61b).

- (61) (a) $[_{CP1} \text{ *How}_i \text{ does John } \underline{\text{regret}} [_{CP2} \text{ that Sonia took pictures in Xin Jiang } t_i \text{ ?}$



Evaluation set for CP2 specified by default rule

- (b) $[_{CP1} \text{ How}_i \text{ does John } \underline{\text{believe}} [_{CP2} \text{ that Sonia took pictures in Xin Jiang } t_i \text{ ?}$



Specifies evaluation set for CP2

(Nichols, 2001:133)

Thus, Nichols the principle of syntactic movement in (62), replacing previous principles constraining movement such as The Subjacency Principle, The Minimal Link Condition, and Phases of Derivation.

- (62) **Principle of Syntactic Movement:** A(n adjunct) *wh* element *E* may move just as far as the clause from which the evaluation set for the proposition containing *E* is specified.

According to (62), the only way a *wh*-element can move outside of its containing syntactic clause is when semantic factors define a movement domain that is larger than a single clause. This is quite different from the traditional view that movement out of clauses is free by default, but is constrained in some cases by blocking effects.⁶⁴

It is interesting to compare Nichols treatment of factive islands to the Scope Theories discussed in Szabolcsi 2002/2006.⁶⁵ Both types of theory argue for a semantic treatment of factive islands, but achieve their results in very different manners. Nichols' assertive operator opens up a semantic domain for movement that would otherwise be closed. In the scope theories discussed by Szabolcsi, scopal interveners block movement that would otherwise be possible (by disrupting the connection between the moved item and its trace position). My approach to factive islands differs from both of these in that for me a syntactic difference is responsible for factive islands.

⁶⁴ For Nichols, extraction of referential NPs is also allowed by the extension of a semantic domain, but a different semantic domain than the one that affects adjuncts. She provides *The Principle of Movement for Referential NPs* in (i), *The Thematic Domain Hypothesis* in (ii), and the *General Principle of Syntactic Movement* in (iii).

- (i) (a) A' movement of a referential NP is well formed if both the head and the tail of the chain formed by movement are within the same thematic continuum.
(b) Clauses A to N form a thematic continuum if each pair of adjacent clauses from the most subordinate clause A to clause N are thematically related.
- (ii) Where the movement of a referential *wh*-phrase from A to B is ungrammatical, A and B must not belong to the same thematic domain.
- (iii) All A' movement domains are uniformly determined by semantic principles. (The individual semantic principles that determine the domains may differ).

Both types of movement (adjunct and referential NP) are allowed out of single clauses when a semantic domain is extended: a modal domain for adjuncts, and a thematic domain for referential NPs. For a detailed discussion see Nichols (2001:Chapt. 3).

⁶⁵ Szabolcsi discards 'factivity' terminology in favor of the 'Stance Predicates' of Cattell 1978. I make the same move, using Hegarty's (1992) modified version of Cattell's classes. See Chapter 2 for discussion.

The operator in my system is a clear descendent of Nichols' operator, with the same basic semantic motivation. However, we part ways in how we derive the factive island constraint. Nichols can clearly handle the factive island facts that I do in her system, with the added benefit that she doesn't need to propose any syntactic difference in addition to her operator (with no need to appeal to the 'Adjunction Prohibition'). However, the extra structure I propose helps explain the patterns of adjunction in Sections 3 and 4 of this chapter, allows for the cases of Subject Auxiliary Inversion (SAI) in Irish English in those sections, and allows for embedded verb second (EV2) movement discussed in Chapter 2. In both the SAI and EV2 cases, there is syntactic movement under NCPs (formerly non-factives) that is unavailable under FCPs (formerly factives). Thus it seems that the extra syntactic projection I am arguing for is needed for reasons independent of factive islands. It is not clear how Nichol's semantic domains account would handle the Irish SAI or Swedish EV2 data that I cover. Following her general move of restricting syntactic movement unless a domain is extended, I would assume that the non-SAI/non-EV2 cases would be the norm, while embedded SAI/EV2 would become available through a domain extending operator. However, SAI and EV2 are clearly not movements out of CP and into the matrix clause, so it is not clear how domain extension would work in these cases. In addition, EV2 clauses are strong islands for extraction. Since all EV2 clauses are selected by 'non-factive' predicates we might expect that movement out of an EV2 clause (by an adjunct or argument) would be fine, as Nichols implies that Comp can be skipped over in these cases.⁶⁶ The fact that an EV2 clause is a strong island is surprising under a semantic domain extension view, but falls out from my approach.⁶⁷

⁶⁶ Nichols (2001:136) writes in a footnote, "The question arises as to whether in this new conception syntactic movement occurs in comp-to-comp fashion. Nothing particularly crucial seems to hinge on the answer to this question, but the discussion does imply that movement out of the most embedded non-factive subordinate complement into a higher clause is able to skip the comp of the clause of origin (whether it must do is unclear). From that point on, movement would seem to proceed in comp-to-comp fashion since the landing point of the previous movement – and starting point of each new phase of movement – is comp."

⁶⁷ In the interest of fairness, Nichols does not consider SAI or EV2 data in her manuscript, so I am in a sense arguing not against her, but against my conception of what she might say, which may be wrong. I should also say that the paper I have is an unpublished draft, so all of the details therein may not have been completely worked at the time she distributed it. Finally, I should note that despite the fact that I disagree

Turning now to the scope theories, my analysis examines but one of the myriad of islands discussed in Szabolcsi 2002/2006. My goal is to provide a syntactic analysis of only one – so called factive islands. I have nothing to say about any other types of islands or the analysis they should receive, though it seems clear that a theory of scopal interveners is on the right track for many of them. However, factive islands are less clearly a result of interveners. Both Szabolcsi & Zwarts 1993 and Honcoop 1998 present analyses of factive islands as interveners, but in both cases these islands seem to fall outside the core analysis. Szabolcsi & Zwart present a short (not completely worked out) analysis of how factive islands might fit in to their system, and also note that intensional verbs like *want* and *seek*, which are often classified as scope-bearing operators, do not induce weak islands. Along those lines, intensional verbs (and NCPs) like *think* and *believe* are also intensional and fail to act as interveners. Honcoop admits that both his and Szabolcsi & Zwarts' accounts of what he calls 'Presupposition Islands' require "a small number of additional assumptions" in order to fit factive island in to their accounts. The present account can serve to remove a troublesome case from a Szabolcsi & Zwarts or Honcoop-style semantic analysis of weak islands, potentially saving them from making some unnecessary assumptions.

The approach to the Factive Islands (FCP Islands) presented in this chapter can be seen as a hybrid of the KKRC approach on the one hand, and the Nichols approach on the other. I completely agree with Nichols' view that non-factives are the special case in need of explanation, not factives, and also that there is something 'extra' needed in the semantics of non-factives that is not needed for factives. The operator I propose is essentially the same as Nichols' 'assertive operator' in its semantic contribution, removing the actual world from the evaluation set of worlds for the embedded clause. However, I also follow KKRC in proposing that a syntactic difference is behind the FCP Island phenomenon. For KKRC, factive complement constructions are more complex than non-factives, but I have argued that it is NCPs that are more structurally complex than FCPs, as illustrated in (4) and (5). I take the embedded verb second (EV2) cases presented in Chapter 2 as evidence that there is indeed a syntactic reflex to the assertive

with some of the details of her analysis, the core of what she says has been extremely influential in my thinking on the topic.

operator that Nichols 2001 argues for. EV2 in the presence of an overt complementizer is only allowed under a NCP like *say* in (63), not under a structurally simpler FCP like *regret* in (64).

- (63) (a) Rickard sa [_{cP} [_{CP} [_C att [_{TP} han inte var hemma]]]] [Swe]
Rickard said that he not was home
 (b) Rickard sa [_{cP} att [_{CP} han [_C var [_{TP} inte hemma]]]]
Rickard said that he was not home
 ‘Rickard said that he was not home.’
- (64) (a) Rickard ångrade [_{CP} [_C att [_{TP} han inte var hemma]]] [Swe]
Rickard regretted that he not was home
 (b) *Rickard ångrade **att** [_{CP} han [_C var [_{TP} inte hemma]]]]
Rickard regretted that he was not home
 ‘Rickard regretted that he was not home.’

The Swedish examples in (63) and (64) also provide support for my claim that NCPs have more complex structure than FCPs, as opposed to the KKRC type analyses. The case of Hungarian *azt* (65), also presented in Chapter 2, gives further evidence for the syntactic reality of *cP* (and its associated [OP]), and against a purely semantic account like Nichols 2001.

- (65) (a) Azt_i hiszem [_{cP} t_i [_{CP} [_C hogy [_{TP} Mari okos.]]]] [Hun]
it-ACC I-think Comp Mary smart-is
 ‘I think that Mary is smart.’
 (b) (*Azt) sajnálom [_{CP} [_C hogy [_{TP} Mari okos.]]]]
it-ACC I-regret Comp Mary smart-is
 ‘I’m sorry that Mary is smart.’

Again, the evidence points to extra structure associated with NCPs, in favor of the account in this chapter, not the traditional KKRC story of extra structure for FCPs.

7. Summary

In this chapter I have argued for an extra projection in the CP-field (*cP*) selected by NCP predicates. The presence of the extra projection allows for adjunction to CP under NCP and *wonder/ask* predicates, while the Adjunction Prohibition disallows adjunction to CP under FCP predicates, which directly lexically select CP. Subject Auxiliary Inversion cases in Irish English are also covered by the *cP* analysis. The *cP* projection is further exploited to account for adjunct extraction from NCP complements. I have proposed that adjuncts and arguments move up the tree through different positions (adjunction to CP vs. through SpecCP). The Adjunction Prohibition is not violated in NCP adjunct extraction, as CP is selected by *c*, a functional head. However, adjuncts are trapped under factives, as they cannot adjoin to a lexically selected CP, and therefore lack an escape hatch for movement. The analysis was also shown to account for FCP Islands and also for *wh*-adjunct ordering restrictions in long-distance multiple-*wh* movement in Serbian. Finally, the proposed analysis was compared favorably to previous analyses of FCP Islands.

Chapter 4: Long-distance NPI Licensing

1. Introduction

The previous two chapters discussed two asymmetries in the behavior of sentential complements embedded under NCPs (Novel Complement taking Predicates) versus FCPs (Familiar Complement taking Predicates).⁶⁸ In Chapter 2 we saw that Embedded Verb Second (EV2) was only available from NCP clausal complements, and similarly in Chapter 3 we saw that *wh*-adjunct extraction was only available out of NCP clausal complements. In this chapter we examine a third major asymmetry; the long-distance licensing of Negative Polarity Items (NPIs), available in NCP clausal complements, but not FCP clausal complements.⁶⁹ The NPI *a red cent* needs to be licensed by negation, as shown in (1).

- (1) (a) *Jon has **a red cent** to his name.
(b) Jon doesn't have **a red cent** to his name.
- (2) (a) I don't believe that Jon has **a red cent** to his name.
(b) *I don't regret that Jon has **a red cent** to his name.

In (2a), matrix negation licenses *a red cent* in the embedded clause of the NCP *believe*. However, in (2b) matrix negation fails to license *a red cent* in the clause embedded under the FCP *regret*. This difference is puzzling, given that the only apparent difference between the sentences is in the choice of verb.

⁶⁸ Note again that I have replaced the traditional *non-factive/factive* distinction with the more accurate NCP/FCP distinction.

⁶⁹ I thank Pablo Albizu, Xabier Artiagoitia, Urtzi Etxeberria and Nerea Madariaga for providing the Basque data and judgments in this chapter, and to Enikő Tóth and Barbara Ürögdi for data and judgments from Hungarian. Thanks also to the participants of the 6th CUNY/SUNY/NYU Miniconference (Stony Brook University, 2005) and to the participants at BIDE05 (University of Bilbao-Deusto, 2005), where earlier versions of this work were presented. Parts of this chapter are based on de Cuba (to appear).

1.1. *The Proposal*

In this chapter, I argue that the asymmetry in NPI licensing in (2) can be explained with the same machinery proposed in the earlier chapters. I argue that proposed structures, repeated here as (3) and (4) results in the difference in NPI licensing possibilities. Specifically, the operator in (3) is responsible for mediating the long-distance licensing. When the operator is not present, long-distance NPI licensing is not possible.

(3) **Structure for *Novel Complement taking Predicates (NCP)***

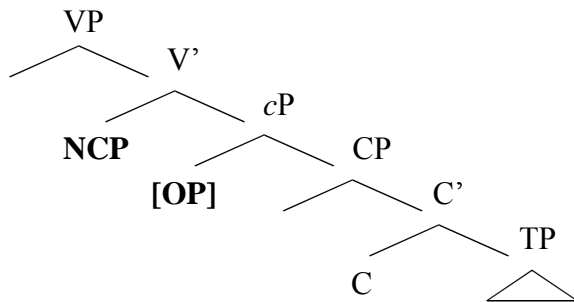

(4) **Structure for *Familiar Complement taking Predicates (FCP)***

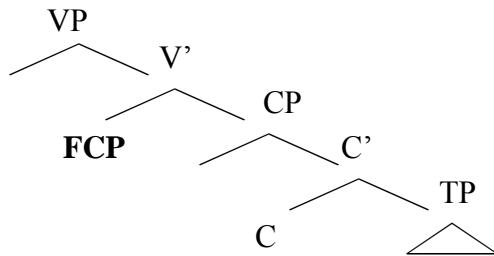

The extra projection, which is present in the NCP structure in (3) but not present in the FCP structure in (4), houses a syntactic negative feature that licenses NPIs when embedded under a matrix negative verb or negated NCP, as in the long-distance case in (2a). I propose that this negative feature is present when *cP* is embedded under a negative element. I will represent the presence of the negative feature as [N-OP]. The lack of the [N-OP] under FCPs, as in (2b), leaves the embedded NPI without a local licenser, crashing the derivation. The licensing I propose is schematized in (5).

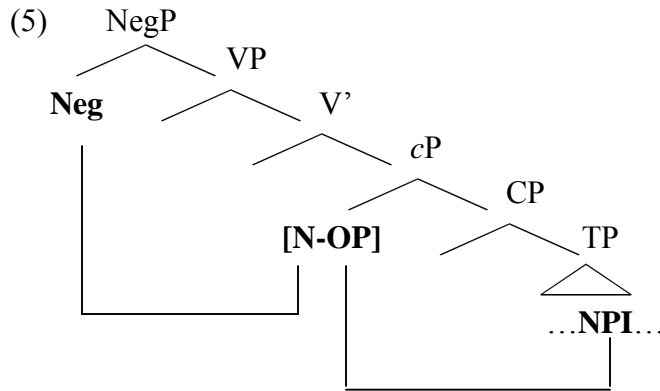

The [N-OP] in (5) licenses the NPI in the embedded TP, and matrix negation licenses the [N-OP]. The mediation performed by the [N-OP] means that a seemingly long-distance NPI licensing case like (2a) is actually just a case of local licensing.

The chapter is organized as follows. In Section 2, I present the Laka 1990 negative complementizer analysis of non-local NPI licensing. It is superficially similar to the current proposal but, as will be seen, it faces certain problems not faced by my proposed analysis. Section 3 presents motivation for my proposal that the operator and extra structure (as in (3)) are found in NCP complements. In Section 4, I argue that the proposed operator and its associated syntactic projection are sometimes optional, and that the so-called negative complementizer in Basque can be decomposed into two separate morphemes, with the second being associated with the operator. Section 5 presents more data from Basque, examining two different types of factive complementation. In Section 6, I present objections to a Laka-style analysis of long-distance NPI licensing from Uribe-Echevarria 1994. I show that the modifications my analysis makes to the Laka analysis eliminates these objections.

2. Laka's Negative Complementizer Analysis

Laka 1990 argues that NPIs in complement clauses can be licensed by a negative complementizer. She gives the data in (6) as evidence that there is an intermediate licenser available to long-distance license NPIs.

- (6) (a) *The witnesses denied **anything**
 (b) I deny [**that**_{NEG} the witnesses denied **anything**] (Laka, 1990:169)

In (6a) the NPI *anything* fails to be licensed by the negative verb *deny* in its own clause, but in (6b) *deny* selects a negative complementizer that in turn licenses *anything* in the embedded clause.⁷⁰ Laka shows that in Basque, unlike English, negative complementizers differ morphologically from their declarative counterparts. In (7a) the declarative complementizer (*e*)*la* appears, while in (7b) the negative complementizer (*e*)*nik* appears under the inherently negative verb *deny*. (7b) also shows that the NPI *inork* (*anyone*) is licensed interclausally, just like English *anything* in (6b).

- (7) (a) [Galapagoak muskerrez beterik daudela] diote [Basq]
Galapagos lizards-of full are-that say-they
 “They say that the Galapagos are full of lizards”
 (b) Amaiak [**inork** gorrotoa dionik] ukatu du
*Amaia anyone hatred has-that*_{NEG} *denied has*
 “Amaia denied that anybody hated her” (Laka, 1990:204-5)

While at first blush Laka’s analysis seems to account for the data, problems arise when we look at more closely at English. First, complementizers are optional under NCPs like *believe*.

- (8) (a) *I believe [(that) Jim **slept a wink** last night]
 (b) I don’t believe [(that) Jim **slept a wink** last night]

(8a) confirms that the NPI *slept a wink* is unlicensed in the absence of negation, while in (8b), *slept a wink* in the embedded clause is grammatical in the presence of matrix negation. The grammaticality of (8b) is not affected in the absence of *that*. This is

⁷⁰ Branigan 1992 argues against the indirect licensing approach proposed by Laka 1990 (at least in some cases), citing examples like (i) where an NPI appears to be licensed within the matrix clause by *deny*.

- (i) (a) *John gave his secretary any raise.
 (b) John denied his secretary any raise.

In (ib) there does not appear to be any negative complementizer available to license the NPI *any*. However, in my analysis to follow I crucially separate the complementizer from the NPI licensing operator (contra Laka 1990), meaning for me the operator is not necessarily dependent on the presence of CP or the complementizer. I discuss these cases in further detail in Chapter 5.

unexpected under Laka's analysis, as for her the negative complementizer is the licenser of polarity items in embedded clauses.

The above problem may be addressed with a PF deletion or null complementizer analysis, but a second, more serious problem arises in the complements of FCPs in English. The NPI licensing that seems to occur long-distance in NCP sentences like (6b) and (8b) does not take place in their FCP counterparts.

- (9) (a) *I regret [(that) Jim **slept a wink** last night]
(b) *I don't regret [(that) Jim **slept a wink** last night]

Under a Laka-style analysis, we would expect (9b) to be grammatical, with the NPI *slept a wink* licensed by *that_{NEG}* which is selected by the negated matrix verb, as in (8b). The fact that (9b) is ungrammatical brings the negative complementizer analysis into question. Given this problem, I argue for a modification to the negative complementizer analysis that maintains the attractive points of Laka 1990 while accounting for the difference between (8) and (9). The structures in (3) and (4) provide a difference in the syntax, with (8b) corresponding to NCP (3) (and (5)), and (9b) corresponding to FCP (4). Crucially, in my analysis the operator is a separate entity from the complementizer. Only in the NCP complement in (3) (and (5)) is there an operator available to license the NPI in the embedded clause.

3. Motivation for the Extra Structure and Operator

The clausal/non-clausal asymmetry in NPI licensing by inherently negative verbs like *deny* and *doubt*, was illustrated in (6). There is no such asymmetry induced by overt negation, as illustrated in (10).

- (10) (a) The witnesses didn't say **that_{NEG} anybody** left the room before dinner.
(b) The witnesses didn't say **anything**. (Laka, 1990:179)

However, Laka's analysis of (10a) is the same as (6b). The negative complementizer is selected by the negated matrix verb, and the NPI *anybody* is licensed by the

complementizer. In Basque, matrix negation also licenses an NPI in a non-negative embedded clause, as in (11). The licensing takes place in the same manner as in (10a), with *anybody* licensed by the negative complementizer.

- (11) **Ez** du Zurinek [**inor** etorriko denik] esan [Basq]
no has Zurine anybody come will AUX-that_{NEG} said
 “Zurine has not said that anybody will come” (Laka, 1990:209)

Laka’s proposal follows Progovac 1988, 1994 in arguing that clauses embedded under inherently negative verbs differ from those embedded under non-negative verbs. While Laka proposes that a different complementizer is selected under negated or negative matrix verbs, Progovac argues for an operator in the head of Comp, as in (12).⁷¹

- (12) I doubt [_{CP} [_C that **OP** [_{IP} **anyone** has come.]]] (Progovac, 1994:67)

For Progovac, this operator is licensed in a clause whose truth-value is not set positively. The operator appears in other contexts with unfixed truth-values, as in (13) through (16), where there is no negative licensing element in the sentence. In her analysis, all of the NPIs in these sentences are licensed by the operator.

- (13) Yes/no questions:
 [_{CP} [_C Has **OP** [_{IP} **anyone** come?]]]
- (14) Conditionals:
 [_{CP} [_C If **OP** [_{IP} **anyone** comes]]], let me know.
- (15) Universal Quantifiers:
 [_{NP} Every man [_{CP} who [_C has **OP** [_{IP} read **anything** by Chomsky]]]]
 will attend the lecture.
- (16) Counterfactual Conditionals:
 [_{CP} Had **OP** [_{IP} **anyone** misbehaved], we would have left.] (Progovac, 1994:67)

⁷¹ See also Giannakidou 1998.

Progovac argues against a strictly Downward Entailing analysis of NPIs (Ladusaw 1980), pointing out that yes/no questions like (13) license NPIs without being Downward Entailing environments. In embedded contexts the operator must be selected by the matrix predicate, as in (12), or by a quantifier, as in (15). Progovac provides further motivation for the existence of this operator. With the proper intonation, a question without Subject Auxiliary Inversion (SAI) is possible, as in (17a).

- (17) (a) He complained about his salary?
 (b) ?*He complained about **anything**?
 (c) Did he complain about **anything**? (Progovac 1994:76-7)

If we suppose that SAI is triggered by an operator in C, then the contrast between (17b) and (17c) falls out: (17b) is out because there is no operator there to trigger movement, and if there is no operator in the structure, there is no licenser for *anything*.

Similar data is presented by den Dikken and Giannakidou 2002, who claim that there is a Q operator in C responsible for licensing NPIs in questions.

- (18) (a) John said something to who?
 (b) *John said **anything** to who?
 (den Dikken and Giannakidou 2002:55, taken from Lee 1994)

Given that the NPI is not licensed in (18b), they conclude that there is no Q operator in C in echo questions. The lack of an operator explains the fact that there is no *wh*-movement to CP in these cases. In order to account for the interrogative interpretation of (18b), they argue that the echo *wh*-word itself hosts a Q morpheme, as in (19).⁷²

- (19) [_{IP} John said something to [who + Q]]? (den Dikken and Giannakidou 2002:55)

⁷² For discussion of Q morphemes, see Hagstrom 1998. den Dikken and Giannakidou 2002 do not discuss yes/no echo questions like those in (17). One might assume that there is a Q morpheme hidden somewhere else in the structure to provide the interrogative interpretation in (17a), since there is no *wh*-word to host the Q morpheme. The details of the analysis are not the main point here. The main point is that NPIs can be licensed by an operator in the CP-field, and that when this operator is not present, NPI licensing does not take place.

Laka 1990 and Progovac 1994 provide evidence that there is a syntactic component to NPI licensing in non-negative contexts, as opposed to the possibility of a purely semantic treatment. The present analysis follows the analyses of Laka and Progovac in proposing an operator that facilitates NPI licensing across a CP boundary, but departs from them by arguing that this operator creates syntactic structure. In Chapter 2, I presented arguments for the presence of the *cP* projection associated with NCPs from Mainland Scandinavian EV2 data. EV2 is only possible under NCPs, and I argued that EV2 movement exploited this extra CP-field projection (*cP*) to allow EV2 movement in the presence of an overt complementizer, as in (20).

- (20) Dan tror att Rickard läste inte boken i dag. [Swe]
Dan thinks that Rickard read not book-the today

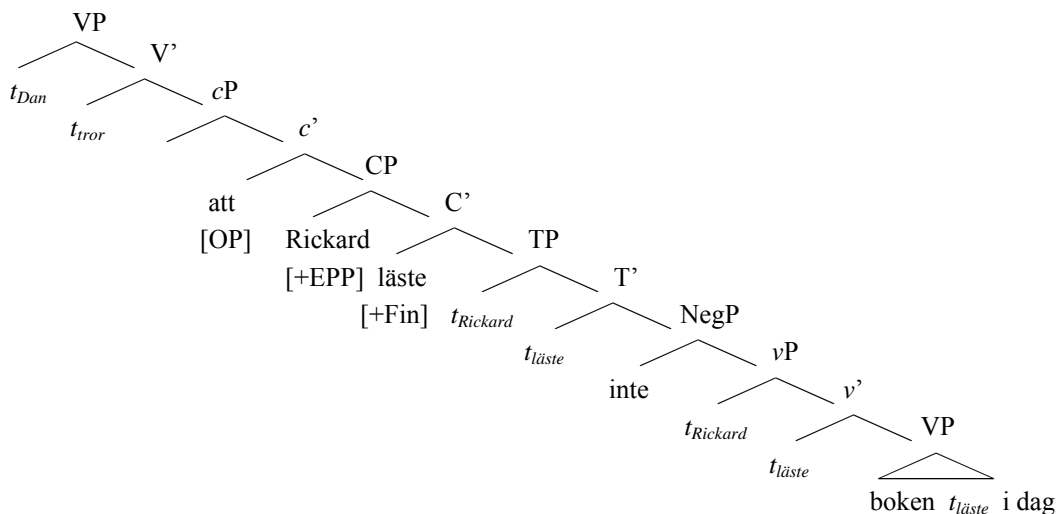

I also argued in Chapter 2 that the [OP] is responsible for lack of presupposition of truth for the embedded clause. In this chapter I claim that the [OP] can also serve as an intermediate NPI licenser when it is licensed by matrix negation or an inherently negative predicate. As illustrated in (21), the same long-distance NPI licensing conditions shown above for Basque and English seem to be at work in Mainland Scandinavian.

- (21) (a) *Jag påstod att tavlan var värd ett ruttet öre [Swe]
I claimed that painting-the was worth one rotten öre
 (b) *Jag tycker om att tavlan var värd ett ruttet öre.
I like (particle) that painting-the was worth one rotten öre
 (c) Jag påstod inte att tavlan var värd ett ruttet öre.
I claimed not that painting-the was worth one rotten öre
 (d) *Jag tycker inte om att tavlan var värd ett ruttet öre.
I like not (particle) that painting-the was worth one rotten öre

In (21a) and (21b) there is no NPI licenser available, while in (21c) long-distance NPI licensing takes place under the NCP *påstod* (*claimed*). This long-distance licensing is unavailable under the FCP *tycker om* (*like*) in (21d). This conforms to the analysis presented in this chapter, that a [N-OP] mediates the seemingly long-distance NPI licensing, and provides more evidence for the existence of the [OP] in cP.⁷³ In the next section, I argue that the proposed operator and its associated syntactic projection are sometimes optional.

4. Optional Extra Structure

In this section I present evidence that the availability of a factive/non-factive reading correlates with syntactic structure cross-linguistically. In fact, some normally NCPs can allow a FCP reading of their complement, and some normally FCPs can allow a NCP reading. I propose that some NCPs have the option to select cP or directly select CP. In cases where CP is selected directly by a NCP, a FCP reading results (the complement is

⁷³ The question might arise as to whether there is any difference between licensing of an NPI by negation, or licensing of an NPI by a [N-OP]. Progovac 1994 shows that Serbo-Croatian has two types of NPIs, NI-NPIs like *niko*, *ništa*, *nikad*, and I-NPIs like *iko*, *išta*, *ikad*. Both sets can be glossed *anyone*, *anything*, *ever* respectively, with the only difference being that the NI-NPIs show morphological negation. NI-NPIs can only appear when licensed by clausemate negation. No long-distance licensing of NI-NPIs is possible. I-NPIs, on the other hand, cannot co-occur with clausemate negation. All cases where I-NPIs are licensed by negation involve long-distance configurations. Progovac, using a binding approach to polarity argues that the difference between NI-NPIs and I-NPIs is that NI-NPIs are only subject to Principle A of the Binding Theory, while I-NPIs are subject to both Principle A and Principle B – with Principle A satisfied at SS and Principle B at LF. She argues that I-NPIs can move at LF, while NI-NPIs cannot, explaining the distribution. In the present analysis, I simply claim that NI-NPIs are licensed by negation, and I-NPIs are licensed by the [N-OP]. As for the morphological difference between the two classes, I follow Uribe-Echevarria (1994:238) in claiming that the *n*-affix is an agreement marker with negation. When negation and the NPI are in the same clause, we see agreement, and when they are in separate clauses we see no morphological agreement.

taken to be familiar, not novel). In addition, some FCPs also have the option to select *cP* or directly select CP. In these cases, a NCP reading results. Basque, English and Hungarian all show syntactic and semantic effects that provide evidence that these optional interpretations are due to the presence or absence of the proposed *cP* and the [OP] in *cP*, not the lexical semantics of the particular verb alone.

4.1. Basque

Basque shows a very interesting complementizer alternation with syntactic and semantic effects relevant to the present discussion. Laka presents a pair of sentences that are identical except for the choice of complementizer.

- (22) (a) Iñigok **ez** du sinisten [lurrak eztanda egingo **duela**] [Basq]
Iñigo no has believed earth explode do will AUX-that
 “Iñigo does not believe that the earth will explode”
- (b) Iñigo **ez** du sinisten [lurrak eztanda egingo **duenik**]
Iñigo no has believed earth explode do will AUX-that_{NEG}
 “Iñigo does not believe that the earth will explode” (Laka, 1990:211)

In (22a) the declarative complementizer (*e*)*la* is present, while in (22b) the negative complementizer (*e*)*nik* appears. Laka describes the semantic difference between the two in the following way: in (22a), the clausal complement *that the earth will explode* is taken to be a fact, one that *Iñigo* happens not to believe. In (22b), *that the earth will explode* is not taken to be a fact; it could be true or false. I argue that this is evidence for the optionality of the operator, and that when it is not present, even under a typically NCP like *believe*, a default FCP reading results. I claim that in (22a) there is no [OP] or [N-OP] present, while in (22b) the [N-OP] is present, resulting in the non-factive reading.⁷⁴

In an investigation of the syntax and semantics of unselected embedded questions, Adger & Quer 2001, following Laka 1990, 1994 and Uribe-Echevarria 1994, argue that

⁷⁴ Laka 1990 analyzes the difference in meanings in (22) as a result of (*e*)*nik* needing to be interpreted under the scope of the negation that selects it, while (*e*)*la* is interpreted outside the scope of matrix negation. Sentences headed by (*e*)*nik* remain in the scope of matrix Infl and V, while those headed by (*e*)*la* undergo Quantifier Raising at LF.

- (25) (a) Azt hiszem hogy Mari okos. [Hun]
it-ACC I-think Comp Mary smart-is
 “I think that Mary is smart.”
- (b) (*Azt) sajnálom hogy Mari okos.
it-ACC I-regret Comp Mary smart-is
 “I’m sorry that Mary is smart.”

In (25a), the pronominal element *azt* represents the object of the matrix verb, which is the lower CP. This pronoun is only present in cases where the matrix predicate is a NCP, as shown in (25b). The fact that *azt* bears accusative case provides evidence that it originates as an argument of the matrix verb. I proposed that *azt* originates in *cP*, present under NCPs but missing under FCPs. When *azt* is not present under a NCP, a FCP reading results, as shown in (26).

- (26) (a) Azt mondta Péter, hogy későn kezdődik a meccs. [Hun]
that-ACC said Peter Comp late begins the match
 “Péter said that the match will begin late” (but we don’t know if this is true)
- (b) Mondta Péter, hogy későn kezdődik a meccs.
said Peter Comp late begins the match
 “Péter told (me) that the match will begin late” (and in fact it will)

As was mentioned in Chapter 2, semantic effects of pronominal elements in Hungarian also occur with some FCPs. Karttunen 1971 and Hooper 1975 classify a group of predicates, called *semifactives*, which pattern with both factives and non-factives. In the verb classification in Hooper and Thompson 1973, these are the Class E predicates (*realize, discover, notice, know*, etc.). The pronominal *úgy* (*so*) shows similar semantic effects to *azt* in Hungarian. When *úgy* appears with semifactives (a subset of FCPs) like *know*, as in (27b), a non-factive reading results.

- (27) (a) Tudja János, hogy Mari okos. [Hun]
knows John that Mary smart-is
 “John knows that Mary is smart”
 (factive reading)
- (b) *Úgy tudja János, hogy Mari okos.*
so knows John that Mary smart-is
 “John knows that Mary is smart”
 (to the best of John's knowledge, Mary is smart)

The presence of *úgy* in (27b) removes the factive interpretation of the embedded clause, while in the absence of *úgy*, the default factive reading results (25a).

I analyze this different semantic behavior as being a result of the presence or absence of *cP* and its associated [OP]. I claim that semifactive predicates can select either *cP* or CP. As the structure is being built from the bottom up, a *cP* merges with CP if the content of the CP is novel information. If it is familiar information, there is no merger with *cP*. Semifactive predicates can select either phrase (*cP* or CP), but different semantic effects result from the selection. In a case like (27a), where CP is directly selected, the complement clause receives a factive interpretation. However, when *cP* is selected, evidenced by the presence of *úgy* in (27b), there is no presupposition that the complement clause is true. In other words, the CP in (27a) has information that is given in the conversational context, while this is not the case in (27b).

Similarly, *said* in (26a) selects a *cP*, signaled by the presence of *azt*. Since the [OP] is present, the embedded CP is not considered given information (not in the conversational background). In my analysis, this semantic notion of non-givenness is marked by *cP*, with the interpretation supplied by [OP]. Even though the selecting predicate *said* in (26b) is a NCP, there is no *cP* present (signaled by the lack of *azt*), and thus the embedded CP is taken as given information, in this case factive.

I take the facts from Hungarian in this section to provide evidence that the [OP] is optional under some verbs. I argue that the observed semantic differences (the availability of what has traditionally been called non-factive vs. factive readings) are due to the presence or absence of the [OP], not simply the lexical semantics of the verb. This means that some NCPs and some FCPs have the freedom to select for either *cP* or CP.

This explains the different semantic behavior that is available under individual predicates, like the NCP *said*, or the FCP *know*. It is not the lexical semantics of the individual predicates that is responsible for this semantic behavior, but whether or not they select for *cP*.

4.4. NPI Licensing in Optional Cases

The analysis presented thus far predicts that long-distance NPI licensing should only take place when the operator is present, which I have argued is signaled in Basque by (*e*)*nik*. Confirmation of this is found in (28).

- (28) (a) **Iñigok ez du sinisten [ezerk eztanda egingo duela]* [Basq]
Iñigo no has believed anything explode do-will AUX-that
 “Iñigo does not believe that anything will explode”
- (b) *Iñigok ez du sinisten [ezerk eztanda egingo duenik]*
Iñigo no has believed anything explode do-will AUX-that
 “Iñigo does not believe that anything will explode” (Laka, 1990:211)

As in (22), the only difference between the two sentences in (28) is in complementizer choice. Under the present analysis, this difference in NPI licensing possibilities results from the lack of an operator in (28a) and its presence in (28b).⁷⁶ Only in (28b) does the NPI have a local licenser, the [N-OP]. The [N-OP] must in turn be licensed by matrix negation or an inherently negative matrix verb.

More support for the analysis in this section comes from English, where the Basque NPI licensing facts in (28) also seem to carry over to (29).

- (29) (a) I don’t believe [that Jon smokes **anymore**].
 *I don’t BELIEVE [that Jon smokes **anymore**].

Recall from example (24), that when stressed, *believe* forces a factive interpretation of the embedded clause. The present analysis predicts that the [N-OP] is responsible for

⁷⁶ This is similar to the Laka 1990 analysis, where the negative complementizer (*e*)*nik* licenses the NPI in (28b). However, my analysis differs from Laka’s in that the operator and the complementizer are separate entities, accounting for the factive/non-factive NPI licensing asymmetry in English in (2).

both the non-local licensing of NPIs, and the availability of a non-factive interpretation. The ungrammaticality of (29b) is thus expected, as there is no [N-OP] available to license the NPI *anymore*, even though *believe* is typically a NCP.

The data in this section provides evidence that semantic effects of the [OP] on truth-value evaluation go along with visible differences in the syntax, in the form of NPI licensing in Basque and English, and extra morphosyntax in Hungarian. I argue that these syntactic licensing and semantic interpretation differences are a result of the presence of the proposed [OP] and its related structure in (3), or the absence of the [OP] and its related structure in (4).

5. Factive Cases in Basque

As was shown in (2), repeated here as (30), in English long-distance NPI licensing is generally available in NCP clausal complements, but not in FCP clausal complements.

- (30) (a) I don't believe [(that) Jim **slept a wink** last night]
 (b) *I don't regret [that Jim **slept a wink** last night]

However, in Section 4 we saw that some FCPs, the semifactives, can sometimes select for *cP*. In Basque, 'true factives' (*regret*, *resent*, *hate*) don't take finite complements, but instead take a nominalization construction similar to the English NP-gerund, as in (31).⁷⁷

- (31) (a) Zuriñek Jon joan **izana** deitoratu du [Basq]
Zuriñe-ERG Jon gone have-ART regret AUX
 "Zuriñe regrets that John left" (lit: John having left)
- (b) Zuriñek ez du Jon joan **izana** deitoratu
Zuriñe-ERG no AUX Jon gone have-ART regret
 "Zuriñe doesn't regret that John left" (lit: John having left)

⁷⁷ *True factives* are also referred to as *emotive factives* in the literature.

Clausal complement constructions using the complementizers *(e)la* or *(e)nik* under true factives are ungrammatical in Basque. However, unlike true factives, semifactives in Basque (*realize, forget, notice*) do take finite complements, as in (32).

- (32) (a) Zuriñe ez da konturatu [gaur astelehena **dela**] [Basq]
Zuriñe no AUX realize today Monday AUX-that
 “Zuriñe hasn't realized that today is Monday”
- (b) Zuriñek ez du ahaztu [gaur bere egun-a **dela**]
Zuriñe no AUX forget today her day-ART AUX-that
 “Zuriñe hasn't forgotten that today is her birthday”

The grammatical sentences in (32) use the complementizer *(e)la*. However, if the complementizer is switched to *(e)nik*, as in (33), the sentences become very awkward, if not totally out.⁷⁸

- (33) (a) *?Zuriñe ez da konturatu [gaur astelehena **denik**] [Basq]
Zuriñe no AUX realize today Monday AUX-that
 “Zuriñe hasn't realized that today is Monday”
- (b) *?Zuriñek ez du ahaztu [gaur bere egun-a **denik**]
Zuriñe no AUX forget today her day-ART AUX-that
 “Zuriñe hasn't forgotten that today is her birthday”

The fact that the *(e)la* examples in (32) are fine, while the *(e)nik* examples in (33) are degraded conforms to what we would expect given the present analysis; the *(e)nik* examples in (33) are all out because *(e)nik* cannot appear in a factively evaluated CP.⁷⁹ Apparently Basque differs from Hungarian in the selectional properties of the different predicate classes. In Hungarian, true factives select for CP, while semifactives are sometimes able to select for *cP* or CP. In Basque, true factives select the nominalized structure in (31), but not CP. Basque semifactives select CP, but differ from Hungarian

⁷⁸ Xabier Artiagoitia and Nerea Madariaga (p.c.).

⁷⁹ In some Basque dialects however, *(e)nik* is possible under factives (Urtzi Etxeberria, p.c.). At this point I will only consider the dialects that disallow factive *(e)nik*, and leave these cases to future research.

semifactives in that they lack the option to select *cP*. It is not surprising to find cross-linguistic variation in the selectional properties of true factives and semifactives.⁸⁰ What I am arguing is universal is the need for extra structure (and the [OP]) in NCP contexts, not FCP contexts.

Finally, (34) illustrates the expected result that an NPI should not be licensed under semifactive *realize*, regardless of the complementizer chosen. Both sentences are ungrammatical.

- (34) (a) *Zuriñe **ez** da konturatu [**inor** etorriko **denik**] [Basq]
Zuriñe no AUX realize anybody come-FUT AUX-that
 “Zuriñe hasn’t realized that anybody will come”
- (b) *Zuriñe **ez** da konturatu [**inor** etorriko **dela**]
Zuriñe no AUX realize anybody come-FUT AUX-that
 “Zuriñe hasn’t realized that anybody will come”

In (34a), *(e)nik* cannot be selected by semifactive *realize* in Basque, since Basque semifactives can only select CP. In (34b), long-distance NPI licensing is not possible in the absence of the operator, signaled by the choice of *(e)la*.

⁸⁰ It is interesting to note the different behavior here of so-called emotive or true factives (like *regret*, *resent*, and *hate*) vs. semifactives like (*realize*, *forget* and *notice*). Icelandic has a related phenomenon.

- (i) Ég hata að Jón skuli hafa barið Maríu [Ice]
I hate that John should have hit Mary
- (ii) Ég veit að Jón hefur barið Maríu
I know that John has (ind.) hit Mary
- (iii) Ég tel að Jón hafi barið Maríu
I believe that John has (subj.) hit Mary

The true factives, which use the nominalization structure in Basque, correspond to true factives in Icelandic, which according to Thráinsson (1979:211-13) take complement clauses with the modal *skuli* (i). Semifactives in Icelandic take complement clauses in the indicative mood (ii), while non-factives take the subjunctive mood (iii). In addition, according to Thráinsson, long-distance reflexivization is possible through true factives with the modal *skuli* (as in (i)) and non-factives subjunctives (as in (iii)), but not through semifactive indicatives (as in (ii)). At present I offer no analysis of these facts, but present them to show that the true factive vs. semifactive split has syntactic realizations cross-linguistically.

6. Tense and Long-distance NPI Licensing

6.1. Uribe-Echevarria 1994

Uribe-Echevarria 1994 presents interesting data on NPI licensing that calls a Laka 1990 negative complementizer-style analysis into further doubt. The ungrammaticality of (35c) comes as a surprise if we assume that a negative complementizer licenses the NPI *anybody* in (35a) and (35b).

- (35) (a) [That **anybody** would leave the company] wasn't mentioned in the meeting.
(b) [That **anybody** had left the company] wasn't mentioned in the meeting.
(c) *[That **anybody** will leave the company] wasn't mentioned in the meeting. (Uribe-Echevarria 1994:92)

There appears to be no structural difference between the sentences: the only difference between the sentences is that the reference-times in the clauses in (35c) are different. The examples in (36) show that it is not the different reference-times alone that causes ungrammaticality, as (36c) is fine. This shows that the ungrammaticality of (35c) is due to the NPI not being licensed. (37) shows that it is not *will* that is incompatible with a NPI.

- (36) (a) [That **Peter** would leave the company] wasn't mentioned in the meeting.
(b) [That **Peter** had left the company] wasn't mentioned in the meeting.
(c) [That **Peter** will leave the company] wasn't mentioned in the meeting. (Uribe-Echevarria 1994:93)

- (37) ?[That **anybody** will leave the company] will not be mentioned in the meeting. (Uribe-Echevarria 1994:94)

The sentential subject data in (35) are paralleled by sentential object cases. In (38c) the different reference-times again lead to ungrammaticality when the NPI *any* is present.⁸¹

- (38) (a) Mary didn't say [that Ann would read **any books** tomorrow].
(b) Mary didn't say [that Ann had read **any books** last week].
(c) ?*Mary didn't say [that Ann will read **any books** tomorrow].
(Uribe-Echevarria 1994:95)

Again, the ungrammaticality arises from the NPI being unlicensed in an embedded clause with a different reference-time from the matrix clause, not simply from being in a clause with *will*.

- (39) Mary will not say [that Ann will read any books tomorrow].
(Uribe-Echevarria 1994:96)

As Uribe-Echevarria notes, the examples in (35) through (39) present a problem for the negative complementizer analysis, as there seems to be no principled way to say that the negative complementizer is present in the grammatical cases but not present in the ungrammatical cases.⁸²

In order to account for the problematic data in (35) through (39), Uribe-Echevarria proposes that NPI licensing takes place at LF. She argues that in the grammatical cases the NPIs are licensed by C-command at LF, while in the ungrammatical cases they are not. Tense complexes are subject to morphological licensing requirements. The reference-time of a clause is determined by structural conditions, so the LF position of a clause conditions the way the tense complex is interpreted. Since the morphological tense features are checked at LF, clauses must

⁸¹ Uribe-Echevarria notes that there seems to be a dialectal split in judgments on the grammaticality of (38c), with dialect A speakers rejecting it and dialect B speakers accepting it. For further discussion of this dialectal split, see her appendix (Uribe-Echevarria 1994:242).

⁸² Assuming of course a SS (surface structure) account of NPI licensing, as in Laka 1990. It may be possible to translate Laka's account to an LF account, but Uribe-Echevarria argues against this possibility. She gives examples of double embedding as evidence against Laka's account, but I will show below that under my analysis, where the [OP] is separate from the complementizer, the double embedding cases are not a problem.

sometimes undergo LF movement in order to license these tense features. In the sentential object cases in (38a) and (38b), the matrix event-time agrees with the embedded clause reference-time. This agreement relationship is on the surface and at LF, satisfying the morphological tense licensing requirements. In (38c) however, [+past] *didn't* and [-past] *will* do not agree; therefore the embedded clause must raise to the matrix clause at LF and form an agreement relation with the utterance-time, which is [-past] by default. The embedded clause in (38c) is forced to raise for tense reasons, but this raising removes the NPI *any* from the C-command domain of negation (in Uribe-Echevarria's analysis it raises above matrix negation), so the sentence is ungrammatical. (40) shows that the same sentence without the NPI is grammatical.

- (40) Mary didn't say [that Ann will read **those books** tomorrow].
 (Uribe-Echevarria 1994:100)

For the cases in (35), Uribe-Echevarria proposes that the sentential subjects must lower (or reconstruct) at LF to satisfy morphological tense licensing requirements. (35c) cannot lower, as there is no tense agreement, so the NPI *anybody* remains outside of the C-command domain of negation and the sentence crashes.

While the LF account given by Uribe-Echevarria seems incompatible with a Laka-style negative complementizer analysis, I will show that it is compatible with my account of long-distance NPI licensing. If we assume that Uribe-Echevarria is correct in proposing that in examples (35c), (36c), (37), (38c) and (40) the embedded clause must move to the matrix clause at LF to properly license morphological tense, then I will need to show how NPI licensing is ruled out in these examples in my system without ruling out the grammatical cases with morphological tense agreement and NPI licensing (35a,b), (38a,b).

6.2. Uribe-Echevarria's First Argument Against a Neg-Comp Analysis

Uribe-Echevarria gives two major arguments for dispensing with the negative complementizer in NPI licensing. The first has to do with the asymmetry in NPI licensing

in object position in negated predicates vs. inherently negative predicates. I will leave a discussion of this to Chapter 5. Her other main argument for getting rid of the negative complementizer comes from double embedded cases like (41).

(41) Juan didn't believe [**that**_{Neg} Peter had said [**that** you owed him **any money**]].

Uribe-Echevarria argues that in Laka's analysis the combination of the matrix predicate and negation select the negative complementizer. In the double embedded case in (41), the second *that* is selected by a non-negated predicate, and therefore should not be a negative complementizer. If NPI licensing is local, as Laka argues, then there should be no licenser for the NPI in the most deeply embedded clause, contrary to fact. However, this is not a problem for the analysis that I have put forth in this chapter, where the [OP] is not dependent on the combination of negation and the complementizer.

I have argued that the [OP] is selected by NCPs, so I would give (41) the structure in (42).

(42) Juan didn't believe [**OP** that Peter had said [**OP** that you owed him **any money**]].

Assuming a bottom up derivation, we begin by constructing the most deeply embedded clause. The NPI is licensed by the operator, which has a negative feature as in (43).

(43) [_{cP1} **N-OP** [that you owed him **any money**]].

The derivation continues, with the [N-OP] needing to be licensed by a negative element in the next highest clause. Again, a [N-OP] is merged in cP2, providing a negative licenser for the [N-OP] in cP1, as in (44).

(44) [_{cP2} **N-OP** [that Peter had said [_{cP1} **N-OP** [that you owed him **any money**]]]].

Finally, the matrix clause is merged, licensing the [N-OP] in cP2, completing the seemingly long-distance NPI licensing without the need to rely on the negative

complementizer being selected by the verb + negation in every clause.⁸³ This essentially eliminates Uribe-Echevarria's concerns about double embedded clauses.⁸⁴ In all of her grammatical examples above my [N-OP] would also be licensed at LF, while in her ungrammatical examples in (35c) and (38c) the [N-OP] would remain outside of the scope of matrix negation, leaving it unlicensed.

More evidence for the analysis I have proposed comes from the ungrammaticality of (45), where we replace the NCP *said* with the FCP *regretted*.⁸⁵

(45) *Juan didn't believe [N-OP that Peter regretted [that you owed him **any money**]].

In my analysis, FCPs like *regret* in (45) do not select *cP*, meaning there is no place for the [N-OP], leaving *any money* without a local NPI licenser. This explains the ungrammaticality of (45). It is not clear how Uribe-Echevarria would deal with the ungrammaticality of (45) in her analysis, as she claims NPI licensing is simply C-command at LF. Following her logic, the most deeply embedded clause, which contains the NPI, would have to move above the matrix negation at LF to stop this licensing from occurring. One could imagine a story where factive clausal complements raise to the

⁸³ Despite the presence of an intervening phase (*vP*) between the [N-OP]s in *cP*1 and *cP*2 in (44), licensing is possible. As discussed in Chapter 2, I assume that *cP* is a phase-edge widener, meaning that the edge of the phase is widened when *c* merges with CP to include *cP* and the head and specifier of CP. When the *vP* phase is completed, the complement of the *cP*1/CP1 complex is spelled out, but the edge of *cP*1/CP1 remains available for syntactic operations. The complement of *vP* (including the *cP*1/CP1 edge) remains open until the completion of *cP*2/CP2. I assume that a CP-phase is not completed until CP is merged with a higher head. In the case where CP is merged with a V, then the lower *vP* phase closes. However, when CP merges with *c*, then the *cP*/CP-complex phase is not completed until *cP* merges with a V. In a structure like (44), this allows the [N-OP] in *cP*1 to be in a licensing relationship with the [N-OP] in *cP*2

⁸⁴ Again, I will return to Uribe-Echevarria's other argument in Chapter 5.

⁸⁵ Note that (45) reports my judgments, but the judgments are mixed. In my grammar, the presupposition of truth of the clause embedded under a factive survives, even if that factive is embedded under a non-factive, as in (i).

(i) John believes [that Bill regrets [that the Earth is flat]].

I also judge sentences like (45), with a factive clause intervening between a negated non-factive, as bad. So for me, both (45) and (i) are bad. One alternative judgment accepts (1), with the non-factive canceling the presupposition, but still rules out the NPI licensing in (45). In this case, one [OP] is enough to globally cancel any presuppositions, but NPI licensing remains a local affair. In the second alternative judgment however, both (i) and (45) are acceptable. This seems to go against the analysis proposed here, as the NPI licensing seems to be non-local. While my analysis can cover the first two judgments, the third remains an open question (specifically, the mechanics of the licensing of the NPI in (45) for the third judgments.).

matrix clause, as seems to be the case for Laka 1990 and Berman 1991.⁸⁶ As Uribe-Echevarria (1990:160) notes though, if binding effects are also an LF phenomenon, we might expect the Condition C violation in (46) to be remedied by LF movement, contrary to fact.

(46) *Juan believes [that **he**_i regrets [that you owe **Peter**_i money]].

I have illustrated here that Uribe-Echevarria's double embedded cases, while a problem for a negative complementizer analysis, are fully explained in my analysis. Her second main argument has to do with NPI licensing by inherently negative verbs in what seem to be a single clauses, as in the examples in (47).

(47) (a) John denied **any involvement** in the crime.
(b) John denied **any wrongdoing**. (Uribe-Echevarria 1994:178-179)

For Laka 1990 these are problematic, as there seems to be no way to posit a negative complementizer in these sentences. However, as with the double embedded cases, my analysis provides a way out of this problem. I return to this in Chapter 5, where I consider the presence of the [OP] and [N-OP] in contexts that are arguably not CP-level constructions.

7. Summary

In this chapter I extended the main proposal to account for cases of non-local NPI licensing. A negative operator [N-OP] in the head of *cP* serves as an intermediate licenser NPIs when embedded under a matrix negative verb or negated NCP. The mediation performed by the [N-OP] means that a seemingly long-distance NPI licensing is actually just a case of local licensing. The lack of a *cP* projection (meaning a lack of [N-OP] as well) under FCPs leaves an embedded NPI without a local licenser. My proposal bears similarities to the negative complementizer analysis of Laka 1990, but I crucially separate

⁸⁶ See footnote 74.

the [OP] from the complementizer, a move which I show eliminates one of Uribe-Echevarria's (1994) major arguments against a Neg-Comp-style analysis. Her other major argument will be addressed in Chapter 5, where the operator will be shown to allow non-local licensing of NPIs in clauses smaller than CP. These sub-CP cases will also put more distance between my proposal and Laka's Neg-Comp analysis. I also argued that the *c*P and [OP] are optional under some predicates, and showed that the presence or absence of [OP] in these optional cases produces differences in semantic interpretation and 'long-distance' NPI licensing. Chapter 5 will examine selectional properties of NCPs vs. FCPs, and also explore the possibility that the [OP] phrase can merge with functional projections that are typically analyzed as being smaller than CP-level.

Chapter 5: More on Selection: Other CP Clauses and Clauses Other than CP

1. Introduction

To this point I have been exclusively discussing Novel Complement-taking Predicates (NCPs) and Familiar Complement-taking Predicates (FCPs) selecting a CP-level complement, with NCPs generally selecting *cP* and FCPs generally selecting CP. However, some of these predicates have the ability to select for complements that are widely regarded in the literature to be smaller than CP, such as the exceptional case-marking (ECM) construction in (1a), the small clause (SC) construction in (1b), and the raising construction in (1c). The control structure in (1d) has been argued to be CP by some, but smaller by others.

- (1) (a) I consider George to be a liar.
- (b) I consider George a liar.
- (c) George appears to be a liar.
- (d) George promised to fire Donald.

The verb *consider* is a NCP, and is capable of taking a CP-level complement, as in (2a).

- (2) (a) I consider that George is a liar.
- (b) I consider [_{*cP*} OP [_{CP} that George is a liar]].

In the analysis presented thus far in the previous chapters, I claim that a sentence like (2a) has the structure in (2b), with the NCP *consider* selecting *cP*, which contains an operator [OP], and that *cP* selects CP. The [OP] is responsible for the embedded clause *George is a liar* not needing to be evaluated as true for the whole sentence to be evaluated as true. In other words, I have argued that the [OP] is necessary in any context where a proposition is not included in the conversational background. However, there appears to be no CP available in the sentences in (1) for *cP* to select, and therefore it seems like there is no place for the [OP] in these sentences. This presents a problem for my analysis,

as none of the embedded clauses in (1) is evaluated as true. The question is, what allows the semantic interpretation of the embedded clauses in (1) in the absence of CP and *cP*?

In this chapter I claim that the distribution of what I have been calling *cP* is wider than what I have proposed thus far. In addition to selecting CP, it can also select for other functional categories, such as TP.⁸⁷ As discussed in Chapter 4, an important distinction between my proposal and the negative complementizer proposal in Laka (1990) is that for me the [OP] is not tied to the complementizer. Therefore, its distribution is not tied to CP. This opens up the possibility that the functional projection headed by [OP] can select for TP as well. In Chapter 2, I proposed that *cP* was an extension of the CP projection, and that extended the CP phase. We can think of the selecting phrase in the same way when it selects TP, giving us *tP*, as in (3b).



In both (3a) and (3b) the selecting head is the same, but the phasal properties of the selecting phrase are inherited from the selected phrase. The non-presupposed status of the embedded clause in a construction like (3b) follows from the presence of the [OP], just as I have argued for the CP construction in (3a).

The Chapter will be organized as follows. In Section 2 I discuss the analysis of ECM constructions and raising verbs, analyzing them both as involving selection of *tP*. In Section 3, I analyze control structures as involving *cP* selection, and introduce the possibility that the [OP] can contribute to the binding of PRO. In section 4, I adopt the den Dikken 2006 analysis of small clauses involving a RELATOR-phrase (RP), and propose that there is an *rP* projection parallel to *cP* and *tP*. I use this *rP* analysis to eliminate Uribe-Echevarria's (1994) second main argument against a 'CP-mediated' analysis of long-distance NPI licensing. Section 5 discusses the remaining asymmetries from K&K presented in Chapter 1, concluding that these can all be accounted for by

⁸⁷ As a reminder, my 'little *x*' projections differ from Chomsky's 'little *x*' projections in a number of ways. The main difference is that my 'little *x*' projections like *cP* and *tP* select functional projections, while Chomsky's 'little *x*' projections like *vP* select lexical projections. For discussion, see Chapter 2.

assuming that FCPs select nominal constructions while NCPs select non-nominal constructions. Section 6 ends things with a discussion of attitude nominals, which I analyze in a parallel fashion to FCPs and NCPs. Section 7 is a summary.

2. ECM, Raising verbs and *tP*

Chomsky 1981 analyzes ECM constructions like (1a) as cases of S'-deletion. This S'-deletion occurs in infinitival sentential complements of certain propositional attitude verbs like *expect*, *consider*, and *believe*.

- (4) (a) I expect him to win the race.
 (b) I consider him to be a fool.
 (c) I believe him to be honest

In the examples in (4), case-marking of the pronoun *him* does not involve a thematic relation between the case assigner (the matrix verb) and the pronoun. The S'-deletion allowed for this case assignment to take place. The structure is illustrated in (5).

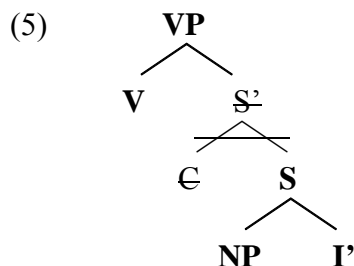

Massam (1985:38) showed that ECM can be accounted for without the need for a deletion rule (as in Chomsky 1981 and Stowell 1981) by specifying that certain verbs can subcategorize for IP. For Massam, case assignment occurs in a complement configuration where a matrix verb governs its complement and the Spec and head of its complement, as shown in (6).

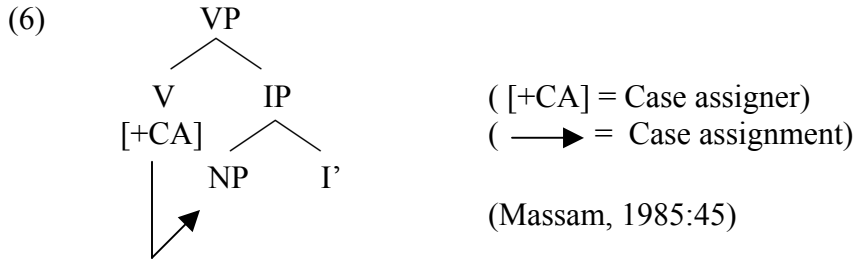

Translating Massam’s proposal into my terms, ECM predicates select *tP*, which select TP, as in (7).

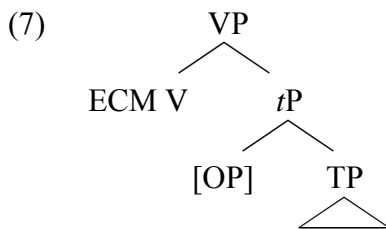

Interestingly, all ECM verbs are NCPs, meaning they select novel clausal complements. When they select a CP-level phrase, they generally select *cP* as opposed to selecting CP directly. Thus it seems like at both the CP and TP levels, NCPs select a phrase headed by [OP]. In essence, they are selecting the same type of phrase, which should not be surprising.⁸⁸ As for accusative case licensing, my structure in (7) is compatible with the *probe-goal* theory of Chomsky 2000, as TP (and by extension *tP*) is not a phase, so the embedded NP in TP is still available for syntactic operations.⁸⁹ The embedded subject can thus be attracted to *vP* by an [+EPP] feature.

Raising constructions, as in (1c), receive a similar analysis to ECM constructions. Raising verbs like *appear* and *seem* also select *tP*, as in (7). Raising verbs differ from ECM verbs in that they do not assign accusative case to their complements. The thematic subject of the embedded TP does not get its case checked in the infinitival construction,

⁸⁸ The selectional system I am proposing can also account for the fact that not all NCPs are ECM verbs. Simply put, non-ECM NCPs are not subcategorized to select a TP-type phrase.

⁸⁹ I follow Chomsky (2005:8-9) in claiming that TP only has phase-like characteristics when selected by C, hence derivatively from C. Merging *t* with TP thus does not make TP phasal.

and it cannot get accusative case from the raising verb, so it gets nominative case from the matrix verb. As with ECM constructions, movement of the embedded NP in raising constructions is allowed given the non-phasehood of *tP/TP*, so the embedded subject moves to the matrix TP to check its [+EPP] feature. Semantically, the [OP] in *tP* performs its usual function of marking the embedded clause as novel content.

3. Control

The correct theory of control sentences like (1d) is an issue that is still up for debate, and I will not attempt to join the fray here. The goal is simply to show that the present theory is compatible with possible analyses of control. Control is standardly taken to involve PRO, and to involve two argument chains, one for the controller and one for PRO. (See Landau, 2003, and references therein).⁹⁰ One popular view has control verbs selecting CP, as opposed to Massam's TP-selecting ECM structure in (6).

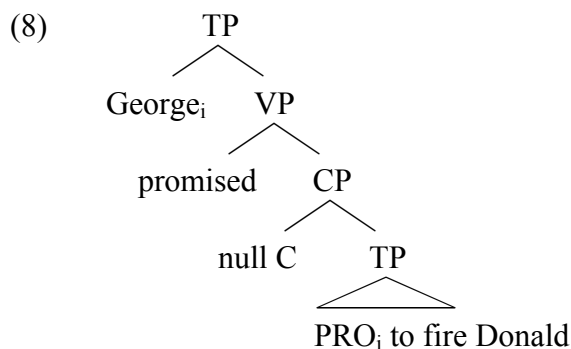

If one thinks of PRO as a [+Anaphor, +Pronominal], as was the case in the GB days of Chomsky 1981, and follow the PRO theorem (PRO must be ungoverned), as presented by Haegeman (1994:272-273), then ungoverned PRO in (8) is licensed. Since *promise* in (8) is a NCP, following the present analysis, the structure in (8) translates into (9).

⁹⁰ I will not discuss movement theories of control such Hornstein 1999, O'Neil 1997 or Martin 1996, though I don't see them as incompatible with the present analysis. For criticism of movement theories of control, see Landau 2003.

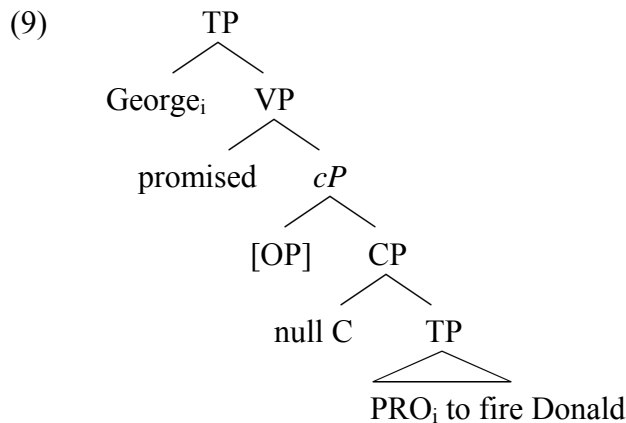

The structure in (9) shares all the virtues of the structure in (8), with the additional power that it gives an explanation for the non-factive interpretation of the embedded CP.⁹¹

4. Small Clauses

Small clauses, like the ECM and Raising predicates discussed above, are another example of non-CP clauses selected by NCPs. Small clauses were first hypothesized to be syntactic units in Williams 1975. A small clause (SC) like (10) is given a structure like (11), with two maximal projections merging under the label SC, for small clause

⁹¹ A question that remains for the PRO theorem analysis is: how does the controller *George* in (8) enter into a relationship with *PRO*? Principle A of the binding theory states that a [+Anaphor] NP must be bound in its governing category. However, given the phase theory of Chomsky 2000, 2001 that I am adopting, it is not clear how the obligatory control relationship can be maintained structurally, as *PRO* is in the embedded CP, and presumably not accessible (in a closed phase) by the time *George* merges in the matrix clause. An intriguing possibility for local licensing of *PRO* opens up given the structure in (9), and the analysis of non-local NPI licensing in Chapter 4. In Chapter 4, I argue that long-distance NPI licensing is mediated by the [OP] in *cP*, with the NPI in an embedded clause licensed by the [N-OP], and the [N-OP] licensed by either matrix negation or an inherently negative matrix verb like *doubt*. Recall also from the discussion of the [OP] in Chapter 2 that in Nichols' (2001) analysis (based on Schlenker 1999), the [OP] changes the <speaker> value away from <+current speaker>, in many cases to the author of a propositional attitude report. In a structure like (9), *George* is the 'author' of the promise, so *George* is responsible for the content of the embedded clause. If one adopted a Nichols/Schlenker-type system, one could then imagine that *PRO* in (9) could get its value locally from the [OP], which we could represent as [OP_G], since it is *George*'s promise, not the speaker's. Just as with the apparent long-distance NPI cases, apparent long-distance control become compatible with phase theory by proving to actually be cases of local licensing. While a full discussion of control phenomena is outside the scope of this work (complications abound, including how to account for object control), the present analysis provides intriguing possibilities for the licensing of *PRO* across a CP-boundary, a lingering problem in the theory of control. I leave a detailed a principled account of this to future research.

(structures from Moro 2000:34). A SC construction like (1b) would then receive the structure in (12).

(10) ...[[_{DP} the cage] [_{AP} empty]].

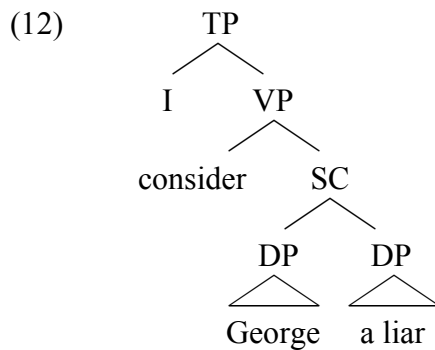
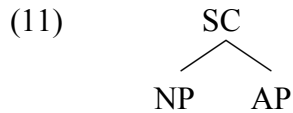

The SC analysis in (11) proved to be problematic for the theory for a number of reasons, one being that neither of the DPs in (12) project, making the SC headless, a violation of X'-theory. Subsequent works (Kayne 1985, Moro 1988, Bowers 1993) sought to bring the structure in line with X'-theory by proposing that a functional projection like Agr could relate the constituents of the SC, as in the structure from Moro 1988 in (13).

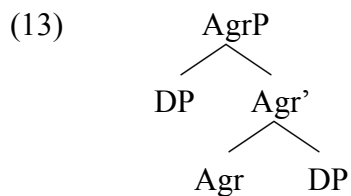

Given more recent developments in the theory (Chomsky 1995b), Agr projections have fallen out of favor. Additionally, given that (13) is an agreement projection, we might expect that the DPs in would agree. As Moro 2000 notes however, even in a rich

agreement language like Italian, there is no agreement between the DPs in the SC in (14), which differ in gender and number.

- (14) Gianni ritiene [_{SC} [_{DP} questi libri] [_{DP} la causa della rivolta]].
Gianni considers these books the cause of-the riot
 (Moro 2000:35)

den Dikken 2006 also argues that all small clauses are related through a functional projection, but instead of an Agr projection, he posits a ‘RELATOR’ phrase, as in (15).

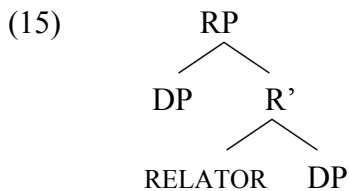

The relationship between a secondary predicate and its subject is mediated by the RELATOR-head. RELATOR is a cover term for any functional projection that mediates between a subject and predicate, and thus is not a newly proposed functional head (it can be realized by T, for example). I adopt den Dikken’s SC analysis, as it allows a uniform treatment of [OP] phrase selection; [OP] phrases select for functional heads. The exact nature of the functional projection headed by the RELATOR in SCs is not important for the present analysis; what is important is that the RP in (15) is a functional projection, just as CP and TP, both of which can be selected by the [OP]-phrase, which then surface as *cP* and *tP* respectively. Following the logic then, the [OP] can also select a RP, providing the SC structure in (16), where *rP* selects RP.⁹²

⁹² In his recent work on small clauses, den Dikken (2006, 2007) argues that RP is a phase. I have claimed that my ‘little *x*’ projections inherit the phasal properties of the functional projections they merge with. If RP is indeed a phase, my operation of phase-edge widening would continue to ensure that the small clause subject can be case-licensed, as SpecRP remains part of the widened phase-edge in my account. In this position it remains visible to outside probes.

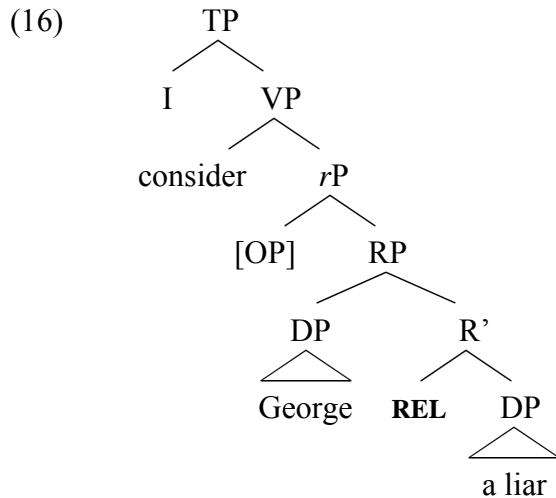

Again it is important to note that NCPs select the xP [OP] phrase in cP , tP and rP constructions, while FCPs do not.

4.1. Uribe-Echevarria's Second Argument Against a Neg C Analysis.

I now return to the discussion of the Uribe-Echevarria 1990 arguments against a CP-mediated analysis of long-distance NPI licensing. In Chapter 4, I showed that in my analysis, the [OP] is present in all NCP complements, diffusing Uribe-Echevarria's concerns in long-distance NPI licensing in double embedded cases like (17).

- (17) Juan didn't believe [_{cP2} **N-OP** [that Peter had said [_{cP1} **N-OP** [that you owed him **any money**]]]].

In (17), long-distance NPI licensing is mediated by a series of [N-OP] heads with a negative feature. While in Laka's (1990) analysis the negative complementizer is selected by a combination of matrix negation and the matrix verb, I analyze the [OP] as being selected by all NCPs, regardless of negation. The [OP] can then host a negative feature, creating a [N-OP] as in (17), making a seeming case of long-distance licensing actually a local operation.

Uribe-Echevarria's other main argument against a CP-mediated licensing analysis is based on negative and adversative predicate data presented in Branigan 1992. Laka's

original motivation for a negative complementizer analysis came from the licensing asymmetry in (18).

- (18) (a) *The witnesses denied **anything**
(b) I deny [**that**_{NEG} the witnesses denied **anything**] (Laka, 1990:169)

The adversative (inherently negative) verb *deny* does not license an NPI in its object position in (18a), but does license the NPI in its clausal complement (indirectly, via the Neg C) in (18b). However, Uribe-Echevarria presents data that seems to contradict the claim that NPIs can't be licensed in complement position.

- (19) (a) John denied **any involvement** in the crime.
(b) John denied **any wrongdoing**. (Uribe-Echevarria 1994:178-179)

The examples in (19) seem to be a problem for a CP-mediated account, as there is no obvious CP in any of the sentences in (19). However, as Uribe-Echevarria notes, the objects in (19) take propositional content. One could easily analyze these sentences as SC constructions den Dikken-style.⁹³ In (19a), *in the crime* can be treated as a predicate of *any involvement*, as in (20).

- (20) John **denied** [_{LP} [N-OP] [_{RP} [**any involvement**] [_{R'} REL [in the crime]]]].

In addition, a plausible approach to (19b) would be to take *any wrongdoing* to be the subject of an empty existential predicate, as in (21).

- (21) John **denied** [_{LP} [N-OP] [_{RP} [**any wrongdoing**] [_{R'} REL [*existence-PRED*]]]].

However, the NPI licensing by [N-OP] in (20) and (21) is not available in the simple case of *deny* selecting a simple NP/DP in (22).

⁹³ Thanks to Marcel den Dikken (p.c.) for suggesting this analysis for the examples in (19).

(22) *John denied [DP anything].

Another possible counterexample to a CP-mediated style account presented by Uribe-Echevarria comes from Branigan 1992. The NPI *any raise* in (23b) is licensed by *deny* in an apparent double-object construction (Larson 1988, 1990).

(23) (a) *John gave his secretary **any raise**.
(b) John denied his secretary **any raise**. (Branigan 1992:58)

Once again, it seems like *deny* is licensing an NPI in complement position. However, I once again follow den Dikken 2006 and analyze double-object constructions as secondary predicates mediated by a functional head, the RELATOR, as in (24).

(24) (a) [VP give [RP [DP the book] [R' REL [PP to Imogen]]]].
(b) [VP put [RP [DP the book] [R' REL [PP on the shelf]]]].
(c) [VP paint [RP [DP the book] [R' REL [AP yellow]]]]. (den Dikken 2006:22)

Note that the verbs in (24) all act as FCPs, with their complements interpreted as given information. However, this givenness disappears with matrix negation.

(25) (a) John didn't give [the book to Imogen].
(b) John didn't put [the book on the shelf].
(c) John didn't paint [the book yellow].

In order to account for the different semantic interpretation between the SCs in (24) and (25), I propose that the negated sentences in (25) contain the [OP]. I have been claiming that any clause whose truth is not accepted in the conversational background must be marked by an [OP] phrase, and these cases are no different. The structure of the examples in (25) then is given in (26), with [OP] in *rP* selecting RP.

(26) (a) John didn't [VP give [_{rP} [N-OP] [RP [DP the book] [R' REL [PP to Imogen]]]].
(b) John didn't [VP put [_{rP} [N-OP] [RP [DP the book] [R' REL [PP on the shelf]]]].
(d) John didn't [VP paint [_{rP} [N-OP] [RP [DP the book] [R' REL [AP yellow]]]].

The structures in (26) thus provide a simple explanation for the grammaticality of (23b). The NPI *any raise* is licensed by the [OP] in *rP*.⁹⁴

(27) John [_{VP} **denied** [_{rP} [**N-OP**] [_{RP} [_{DP} his secretary] [_{R'} REL [_{PP} **any raise**]]]]].

In (23a), there is no [OP] projected and no negative element, so ungrammaticality is expected. When there is matrix negation however, a [N-OP] phrase is projected and licensing occurs, as in (28b).⁹⁵

(28) (a) *John [_{VP} gave [_{RP} [_{DP} his secretary] [_{R'} REL [_{PP} **any raise**]]]]].
 (b) John **didn't** [_{VP} give [_{rP} [**N-OP**] [_{RP} [_{DP} his secretary] [_{R'} REL [_{PP} **any raise**]]]]].

In this section I have shown that Uribe-Echevarria's two main arguments against a CP-mediated-style analysis on NPI licensing, while problematic for a Laka-style negative complementizer, do not apply to my analysis. I have argued that the [OP] is not tied to a complementizer, and it thus can be found in clauses smaller than *cP/CP*, such as *tP/TP* and *rP/RP*.⁹⁶ This allows for the NCP interpretation of these clauses, and the NPI licensing possibilities in NCP complements as found in ECM/Raising constructions and small clause constructions.

⁹⁴ Branigan 1992 provides an ungrammatical example which is very similar to (23b), but with the NPI in the indirect object.

(i) *John denied any employee a raise.

I follow Branigan's analysis that the indirect object must raise at LF for case reasons, leaving the NPI in an unlicensed position at LF.

⁹⁵ The contrast between (27) and (28a) follows from the fact that *deny* can license the [N-OP] on its own, while *give* cannot. *Give* requires negation in order license [N-OP]. In this way, double object taking predicates like *give* behave differently than FCPs like *regret*, which do not take an operator phrase or license a [N-OP], even when combined with negation.

⁹⁶ Again, with RP used as a cover term for whatever functional projection mediates the relationship between a subject and predicate in a SC.

5. More Selectional Differences Between FCPs and NCPs

5.1. Nominal and non-nominal selection

As Kiparsky & Kiparsky (1971) note, there are a number of selectional differences between factive and non-factive predicates, what I am calling FCPs and NCPs respectively. FCPs like *regret*, in addition to selecting for CP, can select for nominal structures like gerundial constructions and adjectival nominalizations in *-ness*, as in (29). NCPs like *think* do not select for these nominal constructions, as shown in (30).

- (29) (a) John regrets his being found guilty
(b) John regrets Bill's having died of cancer last week.
(c) John regrets their suddenly insisting on very detailed reports.
(d) John regrets the whiteness of the whale
- (30) (a) *John thinks his being found guilty
(b) *John thinks Bill's having died of cancer last week.
(c) *John thinks their suddenly insisting on very detailed reports.
(e) *John thinks the whiteness of the whale

In addition, FCPs select for the nominal *the fact* (31a), while NCPs do not (31b). This is also true for the pronominal *it*, which is fine under a FCP (32a), but bad under a NCP (32b).

- (31) (a) I want to make clear the fact [that I don't intend to participate].
(b) *I assert the fact [that I don't intend to participate]. (K&K:347)
(c) I regret the fact [that I came to the party late].
(d) *I said the fact [that I came to the party late].
- (32) (a) Bill resents it [that people are always comparing him to Mozart].
(b) *Bill claims it [that people are always comparing him to Mozart].
(c) I hate it [that he always wears shoes in the house].
(d) *I think it [that he always wears shoes in the house].

Another difference noted by K&K is that FCP complements can appear in Subject position (33a), but NCP complements cannot (34a). Subject position is typically occupied by nominal projections. The same phenomenon is illustrated by the Nichols (2001) examples in (35) and (36).

- (33) (a) [That there are porcupines in our basement] makes sense to me
 (b) It makes sense to me [that there are porcupines in our basement]
 (K&K:346)
- (34) (a) *[That there are porcupines in our basement] seems to me
 (b) It seems to me [that there are porcupines in our basement]
 (K&K:346)
- (35) (a) It is rather surprising [that John arrived late].
 (b) [That John arrived late] is rather surprising.
 (c) It is regrettable [that Mary would want to do such a thing].
 (d) [That Mary would want to do such a thing] is regrettable.
 (Nichols 2001:36)
- (36) (a) It is likely [that Mary slipped in unnoticed].
 (b) *[That Mary slipped in unnoticed] is likely.
 (b) It was hoped [that Donna's foot had healed sufficiently].
 (c) *[That Donna's foot had healed sufficiently] was hoped.
 (Nichols 2001:36)

The generalization we can take from examples (29) through (36) is that FCPs seem to select for nominal complements, while NCPs do not.⁹⁷

There are also cases where NCPs select for complements that FCPs do not. As mentioned earlier in this chapter, NCPs can select for an ECM construction (37a), while FCPs cannot (37b). The same holds for small clause constructions like in (38).

- (37) (a) I believe [Mary to have been the one who did it].
 (b) *I resent [Mary to have been the one who did it]. (K&K:348)
- (38) (a) I consider [George a liar].
 (b) *I regret [George a liar].

I have analyzed the bracketed clauses in both (37a) and (38a) as predicational structures, following den Dikken's (2006) RELATOR analysis. In both cases, the predicational

⁹⁷ K&K analyze both factives and non-factives as selecting an NP which selects S, with the factives having the head noun *fact* in addition (see the discussion in chapter 2). So for them, both factives and non-factives select nominal complements. Factives can take gerunds, as in (29), because there is an optional gerund transformation operation that takes place following nouns, and this can be followed by deletion of *the fact*.

relationship is mediated by a RELATOR, which is a functional projection (RP). The [OP] phrase is able to select these functional projections, marking their contents as containing novel content. The [OP] phrase is then able to be selected by NCPs, and not by FCPs. If we consider [OP] phrases not to be nominal, which clearly seems to be the case, then the selectional generalization remains. FCPs select nominal complements like CP, NP, and gerundial constructions, and do not select non-nominal complements. NCPs, on the other hand, select non-nominal projections like *cP*, *tP* and *rP*, and do not select nominal projections. More evidence for this generalization comes from a constituency test. In the substitution test, the pro-form *so* typically can replace a VP (39), clearly a non-nominal projection.

- (39) (a) Bill ate a cake, and John ate a cake too
 (b) Bill ate a cake, and John did so too.

Under a NCP as in (40a), the phrase *that Bill had done it* can be replaced with *so*, just like the VP *ate a cake* in (39b). However, this can't be done under the FCP in (40b).

- (40) (a) John supposed that Bill had done it, and Mary supposed so too.
 (b) *John regretted that Bill had done it, and Mary regretted so too. (K&K:362)
 (c) Fred thinks that John is foolish, and Phil thinks so too.
 (d) *Fred hates that John is foolish, and Phil hates so too.

In the present analysis, *so* is able to replace non-nominal *cP* in (40a,c), but there is no *cP* to replace in (40b,d), only nominal CP. The pro-form *it* can be substituted for nominals like CP, so since there are CPs present in all of the sentences in (41) (bare CP selected by FCP (41b,d), and CP selected by *cP*, which is in turn selected by NCP *suppose* (41a,c)), all of the substitutions are fine.

- (41) (a) John supposed that Bill had done it, and Mary supposed it too.
 (b) John regretted that Bill had done it, and Mary regretted it too. (K&K:362)

- (c) Fred thinks that John is foolish, and Phil thinks it too.
- (d) Fred hates that John is foolish, and Phil hates it too.

5.2. *Predicates with selectional options*

K&K report on a class of predicates that occur indifferently with factive and non-factive complements, such as *anticipate*, *acknowledge*, *report* and *remember*. K&K claim that these predicates have no specification in the lexicon as to whether they take factive or non-factive complements.⁹⁸ Translated into my terms, these predicates can optionally select for either a familiar or a novel complement, with the familiar being nominal and the novel being non-nominal. The lack of ‘factivity’ in non-nominal complements comes from the [OP] phrase, not from the lexical semantics of the predicate. A predicate like *remember* can select for an ECM complement (42a), or a gerundial construction (42b).

- (42) (a) I remembered him to be bald (so I was surprised to see him with long hair).
- (b) I remembered his being bald (so I brought along a wig and disguised him).
(K&K:360)

(42b) implies that the person is in fact bald, while in (43a) the possibility of a false memory is open. These differing interpretations fall out from the corresponding structures provided in (43).⁹⁹

- (43) (a) I remembered [_{TP} [OP] [him to be bald]
- (a) I remembered [_{NP} his being bald]

The dual behavior of some predicates is also shown when selecting *it*+CP constructions. In (44a) the reading is non-factive, but when *it* is present a factive reading results. The sentence in (44b) suggests that the expectation of a big turnout is fulfilled.

⁹⁸ I discuss optional predicates like these in Chapter 4.

⁹⁹ I use NP as the category for the gerundial construction for ease of exposition. What the exact category should be analyzed as is not crucial for the present discussion. For my purposes it is enough to say that it is a nominal projection.

- (44) (a) I expected that there would be a big turnout (but only three people came)
 (b) I expected **it** that there would be a big turnout (but this is ridiculous – get more chairs) (K&K:362)

Expect behaves semantically like a NCP in (44a), so its structure is as in (45a). It selects the [OP] phrase, giving the novel reading. In (44b) however, *expect* selects nominal *it*, so no [OP] is present, so a FCP reading results. The structure is given in (45b).

- (45) (a) I expected [_{CP} [OP] [_{CP} that there would be a big turnout]].
 (b) I expected [_{NP} **it**] [_{CP} that there would be a big turnout].

6. Attitude Nominals

Nichols 2001 notes that there are a number of nouns whose semantic interpretations closely resemble those of prepositional attitude predicates. She calls these *Attitude Nominals*. Some examples of factive nominals are given in (46), and non-factive nominals in (47).

(46) **Factive Nominals:** *fact, regret, discovery, realization, knowledge, memory...*

(47) **Non-Factive Nominals:** *story, rumor, claim, idea, belief, notion, argument...*

Some examples of attitude nominal sentences are given in (48). Note that the interpretation of the embedded CPs mirrors the interpretation of FCPs and NCPs, with the CPs under both Factive Nominals (48a) and FCPs (49a) containing familiar content, and the CPs under both Non-Factive Nominals (48b) and NCPs (49b) containing novel content.

- (48) (a) Bill came to **the realization** that his wife left him.
 (b) Marilyn holds **the belief** that the earth is flat.
- (49) (a) Bill **realized** that his wife left him.
 (b) Marilyn **believes** that the earth is flat.

However, extraction possibilities differ between Attitude Nominals on one hand and FCPs and NCPs on the other. As was discussed in Chapter 3, NCPs allow extraction of both adjuncts and arguments (50), while FCPs allow argument extraction but not adjunct extraction (51).

- (50) (a) **What** did Adam believe that Eve had eaten *t* ?
 (b) **Why** did Adam believe that Eve had eaten the apple *t* ?
- (51) (a) **What** did Adam realize that Eve had eaten *t* ?
 (b) ***Why** did Adam realize that Eve had eaten the apple *t* ?

Attitude Nominals, on the other hand, are strong islands. Neither Non-Factive Nominals (52) nor Factive Nominals (53) allow any extraction of arguments or adjuncts.

- (52) (a) ***What** did Adam have the belief that Eve had eaten *t* ?
 (b) ***Why** did John have the belief that Mary had eaten the apple *t* ?
- (53) (a) ***What** did Adam come to the realization that Mary had eaten *t* ?
 (b) ***Why** did Adam come to the realization that Mary had eaten the apple *t* ?

While Attitude Nominals pattern semantically with Attitude Predicates, in extraction they pattern with relative clauses (RCs), which are also strong islands (54).

- (54) (a) ***What** did Adam see the woman that had eaten *t* ?
 (b) ***Why** did Adam see the woman that had eaten the apple *t* ?

RCs are often analyzed as adjuncts, and the adjunct status of the RCs in (54) would explain the unavailability of extraction, as adjuncts are strong islands. Nichols 2001 follows this kind of analysis for RCs, giving the sentence in (55a) the structure in (55b).

- (55) (a) The camera that Sonia left behind
 (b) $[_{NP} \text{The camera}_i [_{CP} \emptyset_i [\text{that} [_{IP} \text{Sonia left behind } t_i]]]]$
 (Nichols 2001:178-9)

An operator moves from the gap position to SpecCP, and is co-indexed with the head noun *camera*. Given the similarity in extraction possibilities (or lack thereof) between Attitude Nominals and RCs, Nichols concludes that the CPs under Attitude Nominals are also adjuncts, contrary to traditional assumptions.¹⁰⁰ The Attitude Nominal construction in (56a) receives the structure in (56b), which is parallel to the RC structure in (55b).

- (56) (a) The rumor that Sonia was moving to Xin Jiang
 (b) [_{NP} The rumor_i [_{CP} Ø_i [that [_{IP} Sonia was moving to Xin Jiang]]]]
 (Nichols 2001:178-80)

Nichols analyzes the null operator in (56b) as an event argument, and the head noun *rumor* is co-indexed with the event argument. Co-indexation by a Non-Factive Nominal like *rumor* allows the null operator in (56b) to assign a value to the lower clause <world> variable, the value being <-actual world>. Under Factive Nominals the default <+actual world> value is assigned.

Extending the analysis presented in this chapter, I am able to cover the facts Nichols does without the need to reanalyze Attitude Nominal CPs as adjuncts, or to appeal to a non-Minimalist co-indexation operation. Following de Cuba & Kawamura (to appear), I propose that Non-Factive Nominals select *cP* (58a), and Factive Nominals select *CP* (57b), parallel to *NCPs* (58a) and *FCPs* (58b).

- (57) (a) Non-Factive Nominal (b) Factive Nominal
- ```

 NP
 / \
 N cP
 belief / \
 [OP] CP
 ^

```

```

 NP
 / \
 N CP
 realization ^

```

<sup>100</sup> Nichols is forced into this move given her view that thematic continuums allow for movement. Since argument extraction is not allowed from Attitude Nominals (as illustrated in (52) and (53)), it signals to Nichols that the NP and CP in (56b) are thematically unrelated.

(58) (a) NCP

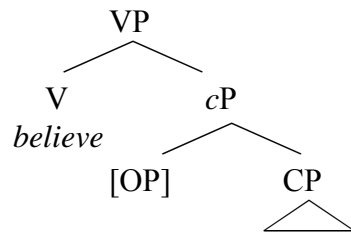

(b) FCP

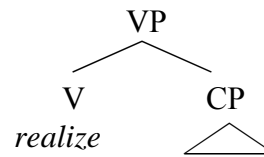

The ungrammatical status of (52) and (53) is simply due to a violation of the Complex Noun Phrase Constraint of Ross 1967. The CNPC can be translated into modern terms if we assume that the NPs in (57) are contained in DPs. Assuming that DP is a phase and that VP is not a phase, the CP/cP-phases in (57) will be closed by the DP-phase, so movement will be ruled out. However, the semantic contribution of the [OP] remains in (57a), despite the unavailability of extraction.

## 7. Summary

In this chapter I have extended my analysis to constructions that are traditionally analyzed as involving complements smaller than CP, like ECM, raising verbs, and small clauses. I analyzed all of these as involving selection of an [OP]-phrase, the same as the one I have proposed resides in the head of cP. I argue that *tP* and *rP* are functional projections that serve the same purpose as cP, to remove the actual world from the evaluation set of the embedded clause. All are versions of the same phrase, which inherits some of the properties of the functional phrase it selects, be it CP, TP, or some other functional projection. The fact that the [OP] I propose in this thesis is separate from the complementizer is crucial in allowing the novel interpretation of clauses smaller than CP.

In addition to clauses smaller than CP, I also examined more CP-level complement constructions, such as control structures and attitude nominals. I analyze control structures as involving cP selecting CP. I analyze attitude nominal in a parallel fashion to FCPs and NCPs. The lack of extraction from attitude nominals is explained by the DP-phase closing the cP/CP-phase. I also discussed the selection properties of FCPs vs. NCPs, concluding that FCPs select nominal complements and NCPs select non-



nominal complements. I exploit this difference in selectional properties to account for the remaining K&K-noted asymmetries presented in Chapter 1.

## References

- Adger, David and Josep Quer. 2001. The syntax and semantics of unselected embedded questions. *Language* 79.4, 2001.
- Andersson, Lars-Gunnar. 1975. *Form and function of subordinate clauses*. Doctoral Dissertation. Göteborg Universitet: Göteborg, Sweden.
- Antieau, Lamont. 2003. Plains English in Colorado. *American Speech*, Vol. 78, No. 4. 385-403.
- Benincá, P., Poletto, C., 2004. Topic, focus and V2: Defining the CP sublayers. In: Rizzi, L. (Ed.), *The Structure of CP and IP*. Oxford University Press, Oxford, New York. 52–75.
- Bloom, L. 1970. *Form and function in emerging grammars*. MIT Press: Cambridge, Mass.
- Bošković, Željko. 2003. On wh-islands and obligatory wh-movement contexts in South Slavic. In *Multiple wh-fronting*. C. Boeckx and K. Grohmann (eds.). 27-50. Amsterdam: John Benjamins
- Bošković, Željko. 2002. On multiple Wh-fronting. *Linguistic Inquiry* 33: 351-383.
- Bošković, Željko. 1999. On multiple feature checking: Multiple wh-fronting and multiple head movement. In *Working Minimalism*, S. D. Epstein and N. Hornstein (eds), 159–187. Cambridge, Mass.: MIT Press.
- Bošković, Željko. 1998. Wh-Phrases and wh-Movement in Slavic. Position paper presented at the Comparative Slavic Morphosyntax Workshop, Spencer, Indiana.
- Bošković, Željko. 1997a. Superiority effects with multiple wh-fronting in Serbo-Croatian. *Lingua* 102:1-20.
- Bošković, Željko. 1997b. Fronting wh-phrases in Serbo-Croatian. In *Formal approaches to Slavic Linguistics: The Indiana meeting. 1996*. M. Lindseth and S. Franks (eds), 86-107. Ann Arbor, Mich.: Michigan Slavic publications.
- Bowers, John. 1993. The syntax of predication. *Linguistic Inquiry* 24:591-656.
- Branigan, Philip. 1992. *Subjects and complementizers*. Doctoral dissertation, MIT, Cambridge, Mass.
- Cattell, Ray. 1978. On the source of interrogative adverbs. *Language* 54.1:61-77.
- Chomsky, Noam. 2005. *On phases*. Ms. MIT.
- Chomsky, Noam. 2001. Derivation by phase. In *Ken Hale: A life in language*, ed. Michael Kenstowicz. Cambridge, Mass.: MIT Press.
- Chomsky, Noam. 2000. Minimalist inquiries: The framework. In *Step by step: Essays on minimalism in honor of Howard Lasnik*, ed. Roger Martin, David Michaels, and Juan Uriagereka, 89-155. Cambridge, Mass.: MIT Press.
- Chomsky, Noam. 1995a. Bare phrase structure. in Gert Webelhuth ed. *Government and Binding Theory and the Minimalist Program*. Cambridge: Blackwell. 383-439.
- Chomsky, Noam. 1995b. *The Minimalist Program*. Cambridge, Mass. MIT Press.
- Chomsky, Noam. 1986. *Barriers*. Cambridge: MIT Press.
- Chomsky, Noam. 1981. *Lectures on Government and Binding*. Foris, Dordrecht.
- Chomsky, Noam. 1973. Conditions on transformations. In *A Festschrift for Morris Halle*. Stephen Anderson and Paul Kiparsky (eds.) 232-286. New York: Holt, Rinehart and Winston.
- Cinque, Guglielmo 1990. *Types of A'-Dependencies*. Cambridge, Mass.: MIT Press.

- de Cuba, Carlos. To appear. Negative polarity licensing, factivity, and the CP field. *The ASJU-International Journal of Basque Linguistics and Philosophy*. Due in 2007.
- de Cuba, C. 2006a. The Adjunction Prohibition and Extraction from Non-Factive CPs. In D. Baumer, D. Montero and M. Scanlon eds., *Proceedings of the 25<sup>th</sup> West Coast Conference on Formal Linguistics*. 123-131. Somerville, MA: Cascadilla Proceedings Project. [www.lingref.com](http://www.lingref.com), document #1440
- de Cuba, Carlos. 2006b. Embedded Verb-Second in Swedish, cP and Intensionality. *Stony Brook occasional papers in linguistics: Intensionality and sentential complementation*. Vol. 1:2-21. T. Kawamura, Y. Suh & R. Larson (eds.). Linguistics Department, Stony Brook University. Available online at: <http://www.linguistics.stonybrook.edu/sbopl/>
- de Cuba, Carlos. 2002. A Phase-derivational analysis of limited embedded V2 in Mainland Scandinavian. Qualifying Paper. Stony Brook University, NY.
- de Cuba, Carlos, and Tomoko Kawamura. To appear. Intensionality and extraction as reflexes of syntactic structure. Paper presented at ConSOLE XV, The Catholic University of Brussels (K.U.B), Brussels, Belgium. January 11-13, 2007. To appear in *Proceedings of Console XV*.
- de Cuba, Carlos, and Franc Marušič. 2003 (handout). On the interpretation of clausal complements. Paper presented at The 4<sup>th</sup> CUNY/SUNY/NYU Mini-conference. The CUNY Graduate Center, NY. March 8, 2003.
- de Cuba, Carlos, and Ivana Mitrović. To appear. Restrictions on *wh*-adjunct movement in Serbian. Paper presented at Formal Descriptions in Slavic Linguistics 6.5. University of Nova Gorica, Nova Gorica, Slovenia. December 1-3, 2006. To appear in *Proceedings of FDSL 6.5*.
- de Cuba, Carlos, and Barbara Ürögdi. 2001. The Role of factivity in the syntax and semantics of embedded clauses. Unpublished manuscript: Stony Brook University, NY.
- de Villiers, J.G. 1998. On acquiring the structural representations for false complements. In B. Hollebrandse (ed): *New perspectives on language acquisition*, University of Massachusetts Occasional Papers in Linguistics, Volume 22:125-136. GLSA, UMass, Amherst.
- Diesing, Molly. 1990. Verb movement and the subject position in Yiddish," *Natural Language and Linguistic Theory* 8:1, 41-79.
- den Besten, Hans. 1983. On the interaction of root transformations and lexical deletive rules. Ed. John Benjamins *On the formal syntax of the Westgermania*. Amsterdam.
- den Dikken, Marcel. To appear. Phase extension: A reply. Ms. CUNY Graduate Center, New York, NY. To appear in *Theoretical Linguistics 2007*.
- den Dikken, Marcel. 2006. Phase extension: Contours of a theory of the role of head movement in phrasal extraction. Ms. CUNY Graduate Center, New York, NY.
- den Dikken, Marcel. 2006. *Relators and Linkers: The syntax of predication, predicate inversion, and copulas*. Linguistic inquiry monographs 47. MIT Press, Cambridge, Mass.
- den Dikken, Marcel, and Anastasia Giannakidou. From *hell* to polarity: Aggressively non-D-linked *wh*-phrases as polarity items. *Linguistic Inquiry* 33.1:31 - 61.

- Emonds, Joe. 1969. *Root and structure-preserving transformations*. Ph.D. Dissertation, MIT, Cambridge, Mass.
- Erteschik-Shir, Nomi. 1973. On the nature of island constraints. Doctoral dissertation, MIT, Cambridge, Mass.
- Giannakidou, Anastasia. 1998. *Polarity sensitivity as (non)veridical dependency*. *Linguistik Aktuell*:23. John Benjamins, Amsterdam/Philadelphia.
- Giorgi, Alessandra & Fabio Pianesi. 1997. *Tense and Aspect: From Semantics to Morphosyntax*. Oxford Studies in Comparative Syntax. New York, Oxford: Oxford University Press.
- Green, Georgia. 1976. Main clause phenomena in subordinate clauses. *Language* 52: 382-397.
- Grewendorf, G., 2002. Left dislocation as movement. In: Mauck, S., Mittelstaedt, J. (Eds.), *Georgetown University Working Papers in Theoretical Linguistics*, vol. 2, Fall. pp. 31–81.
- Haegeman, L. 2006. Conditionals, factives and the left periphery. *Lingua* 116:1651-1669.
- Hagstrom, Paul. 1998. *Decomposing questions*. Doctoral dissertation, MIT, Cambridge, Mass.
- Hegarty, Michael. 1992. Familiar complements and their complementizers: On some determinants of A'-locality. Unpublished manuscript: University of Pennsylvania.
- Henry, Alison. 1995. *Belfast English and Standard English: Dialect variation and parameter setting*. Oxford and New York: Oxford University Press.
- Heycock, Caroline. 2000. Case #35: Embedded root phenomena. Now available as Heycock 2006. Embedded root phenomena. In *The Blackwell companion to syntax*, ed. Martin Everaert and Henk van Riemsdijk, volume II, 174–209. Oxford: Blackwell.
- Holmberg, Anders. 1983. The Finite sentence in Swedish and English. *Working Papers in Scandinavian Syntax*. Linguistics Department: University of Trondheim.
- Holmberg, Anders. 1986. *Word order and syntactic features in the Scandinavian languages and English*. Doctoral Dissertation, Department of General Linguistics: University of Stockholm.
- Holmberg, Anders, and Christer Platzack. 1995. *The role of inflection in Scandinavian syntax*. Oxford University Press.
- Honcoop, Martin. 1998. *Dynamic excursions on weak islands*. Ph.D. dissertation, HIL Universiteit Leiden, LOT dissertations 5, Holland Academic Graphics.
- Hooper, Joan. 1975. On assertive predicates. ed. Kimball, John P. In: *Syntax and Semantics* 4. 91-124. Academic Press: New York.
- Hooper, Joan, and Sandra Thompson. 1973. On the applicability of root transformations. *Linguistic Inquiry* 4: 465-497.
- Hornstein, Norbert. 1999. Movement and control. *Linguistic Inquiry* 30:69-96.
- Iatridou, Sabine, and Anthony Kroch. 1992. The Licensing of CP-recursion and its relevance to the Germanic verb-second phenomenon. *Working Papers in Scandinavian Linguistics* 50:1-25.
- Jackendoff, Ray. 1972. *Semantic interpretation in Generative Grammar*. Cambridge, MA, MIT Press.
- Kaplan, David. 1977. Demonstratives. In *Themes from Kaplan*. ed. Almog, Perry and Wettstein. Oxford University Press, 1989.

- Karttunen, Lauri. 1971. Some observations on factivity. *Papers in Linguistics* 4:55-69.
- Karttunen, Lauri. 1973. Presuppositions of compound sentences. *Linguistic Inquiry* 4.2:169-193.
- Kayne, Richard S. 1994. *The antisymmetry of syntax*. *Linguistic Inquiry monograph* 25. MIT Press.
- Kayne, Richard. 1985. L'accord du participe passé en français et en italien. *Modèles Linguistiques* 7:73-89.
- Kayne, Richard. 1982. Predicates and arguments, verbs and nouns. *GLOW Newsletter* 8:24.
- Kiparsky, Paul, and Carol Kiparsky. 1971. Fact. In *Semantics. An interdisciplinary reader in philosophy, linguistics and psychology*, ed. D. D. Steinberg and L. A. Jakobovits, 345-369. Cambridge: Cambridge University Press.
- Kiss, Katalin É. 2002. *The syntax of Hungarian*. Cambridge University Press, UK.
- Kratzer, Angelika. 1991. Modality. Chapter 23 in Arnim v. Stechow and Dieter Wunderlich (eds.): *Handbuch Semantik/Handbook Semantics*. Berlin and New York: de Gruyter. 639-650.
- Kratzer, Angelika. 1981. The notional category of modality. In H.J. Eikmeyer and H. Rieser: *Words, Worlds, and Contexts*. Berlin, New York: de Gruyter. 38-74. Reprinted in P. Portner & B. Partee (eds.): *Formal Semantics. The essential readings*. Oxford: Blackwell. Also reprinted in Javier Gutierrez-Rexach (ed.), *Semantics: Critical concepts*. London: Routledge.
- Kratzer, Angelika. 1979. Conditional necessity and possibility. In R. Bäuerle, U. Egli and A. v. Stechow (eds.): *Semantics from different points of view*. Berlin, Heidelberg, New York: Springer. 117-147.
- Ladusaw, William A. 1980. *Polarity sensitivity as inherent scope relations*. Garland, New York.
- Laka, Itziar. 1990. *Negation in syntax: On the nature of functional categories and projections*. Doctoral Dissertation, MIT, Cambridge, Mass.
- Laka, Itziar. 1994. *On the syntax of negation*. New York and London: Garland.
- Landau, Idan 2003. Movement out of control. *Linguistic Inquiry* 34:471-498.
- Larson, Richard. 1990. Double objects revisited: Reply to Jackendoff. *Linguistic Inquiry* 21:589-632.
- Larson, Richard. 1988. On the double object construction. *Linguistic Inquiry* 19:335-391.
- Larson, Richard K., and Gabriel Segal. 1995. *Knowledge of meaning*. MIT Press: Cambridge, Mass.
- Lee, Felicia. 1994. *Negative polarity licensing in wh-questions: The case for two licensors*. MA thesis, UCLA, Los Angeles, CA.
- Lipták, Anikó. 1998. A magyar fókuszemelések egy minimalista elemzése. In Büky and Maleczki (eds.). *A mai magyar nyelv leírásának újabb módszerei* III: p. 93-116, Szeged: JATE.
- Martin, Roger A. 1996. *A minimalist theory of PRO and control*. Doctoral dissertation, University of Connecticut, Storrs.
- McCloskey, James. 2005. Questions and questioning in a local English. *Cross-linguistic research in syntax and semantics: Negation, tense and clausal architecture*. Raffaella Zanuttini, Héctor Campos, Elena Herburger and Paul H. Portner, eds., Georgetown University Press.

- McCloskey, James. 2004. Questions and questioning in a local English. Paper presented at Georgetown University Round Table. Handout.
- Melvold, Janis. 1986. Factivity and definiteness. Unpublished Draft, Dept. of Linguistics and Philosophy, MIT, Cambridge, Mass..
- Moro, Andrea. 2000. *Dynamic antisymmetry*. Linguistic inquiry monographs 38. MIT Press, Cambridge, Mass.
- Moro, Andrea. 1988. Per una teoria unificata delle frasi copulari. *Revista di Grammatica Generativa* 13:81-110.
- Nichols, Lynn. 2001. The syntax and morphosyntax of propositional attitude complementation. Ms. Harvard University, Cambridge, MA.
- O’Neil, John H. 1997. *Means of control: Deriving the properties of PRO in the Minimalist Program*. Doctoral dissertation, Harvard University, Cambridge, Mass.
- Progovac, Ljiljana. 1994. *Negative and positive polarity: a binding approach*. Cambridge University Press.
- Platzack, Christer. 1986. Comp, infl, and Germanic word order. ed. L. Hellan and K. Koch Christensen. *Topics in Scandinavian Syntax*:185-234.
- Rizzi, Luigi 1990. *Relativized minimality*. Cambridge/Mass.: MIT Press.
- Ross, John Robert. 1967. Constraints on variables in syntax. Ph.D. Dissertation. MIT, Cambridge, Massachusetts.
- Rudin, Catherine. 1988a. On multiple questions and multiple *wh*-fronting. *Natural Language and Linguistic Theory* 6:445-501.
- Rudin, Catherine. 1988b. Multiple questions in South Slavic, West Slavic, and Romanian. *The Slavic and East European Journal*, Vol. 32, No. 1. (Spring, 1988), pp. 1-24.
- Santorini, Beatrice. 1992. Variation and change in Yiddish subordinate clause word order. *Natural Language and Linguistic Theory* 10, 595–640.
- Schlenker, Philippe. 1999. *Propositional attitudes and indexicality; a cross-categorial approach*. Ph.D. MIT.
- Stjepanović, Sandra. 2003. “Multiple *wh*-fronting in Serbo-Croatian matrix questions and the matrix sluicing construction”. In *Multiple Wh-Fronting*, Boeckx, Cedric and Kleanthes K. Grohmann (eds.). 255–284.
- Stjepanović, Sandra 1998. Short distance movement of *Wh*-phrases in Serbo-Croatian matrix clauses. Paper presented at the Workshop on Comparative Slavic Morphosyntax, Spencer, Ind. (June 1998)
- Stowell, T. 1981. *Origins of Phrase Structure*. Ph.D. dissertation, MIT, Cambridge, Mass.
- Szabolcsi, Anna. 2002.. Strong vs. weak islands. Now available as Szabolcsi 2006. *The Blackwell Companion to Syntax*, ed. by Everaert and van Riemsdijk. vol.4, pp. 479-532.
- Szabolcsi, Anna, & Frans Zwarts. 1993. Weak Islands and an Algebraic Semantics for Scope Taking. *Natural Language Semantics* 1:235-284. (reprinted in: A. Szabolcsi (ed.), *Ways of Scope Taking*, Kluwer Academic Publishers, Dordrecht, 217-262)
- Thráinsson, Höskuldur. 1979. *On complementation in Icelandic*. Garland Publishing.

- Uribe-Echevarria, Myriam. 1994. *Interface licensing conditions on PSIs: A theory of polarity and tense interactions*. University of Connecticut dissertation, Storrs, CT.
- van Riemsdijk, Henk. 1998. Categorical feature magnetism: The endocentricity and distribution of projections. *Journal of Comparative Germanic Linguistics* 2:1-48. Kluwer.
- Vikner, Sten. 1995. *Verb movement and expletive subjects in the Germanic Languages*. Oxford University Press.
- Watanabe, Akira 1992. Larsonian CP recursion, factive complements, and selection. In *NELS 23* (vol. 2). Amherst, MA: GLSA, University of Massachusetts. 523-537.
- Zubizarreta, M-L. 2001. Preverbal subjects in romance interrogatives. In: Hulk, A., Pollock, J-Y. (Eds.), *Subject inversion in Romance and the theory of universal grammar*. Oxford University Press, Oxford, New York, pp. 183–204.
- Zwart, Jan-Wouter. 2006. Complementizer agreement and dependency marking typology. *Leiden working papers in linguistics* 3.2, 53-72.
- Zwart, Jan-Wouter. 2001. Syntactic and phonological verb movement. *Syntax* 4.1, 34-62.
- Zwart, Jan-Wouter. 1993. Clues from dialect syntax: Complementizer agreement. In *Dialektsyntax*, W. Abraham & J. Bayer, eds. Sonderheft 5/1993 der *Linguistische Berichte*, pp. 246-270.
- Zwart, Jan-Wouter. 1991. Clitics in Dutch: Evidence for the position of INFL. *Groninger Arbeiten zur germanistischen Linguistik* 33, 71-92.