

Stony Brook University



OFFICIAL COPY

The official electronic file of this thesis or dissertation is maintained by the University Libraries on behalf of The Graduate School at Stony Brook University.

© All Rights Reserved by Author.

The Evaluation of the Effect of Processing Parameters on Adhesion
Performance of Polyether based TPU over mold on to Polycarbonate
Substrate.

A Thesis Presented

by

Mukund Purushottam Patankar

to

The Graduate School

in Partial Fulfillment of the

Requirements

for the Degree of

Master of Science

in

Materials Science and Engineering

Stony Brook University

December 2010

Stony Brook University
The Graduate School
Mukund Purushottam Patankar

We, the thesis committee for the above candidate for the

Master of Science degree, hereby recommend
acceptance of this thesis.

T.A. Venkatesh Advisor
Assistant professor Department of Materials Science and Engineering

Miriam Rafailovich
Distinguished Professor Department of Materials Science and Engineering

Jonathan Sokolov
Professor Department of Materials Science and Engineering

Vik Bhargava
Director Engineering, Motorola Solutions, Inc

This thesis is accepted by the Graduate School

Lawrence Martin
Dean of the Graduate School

Abstract of the Thesis

**The Evaluation of the Effect of Processing Parameters on Adhesion
Performance of Polyether based TPU over mold on to
Polycarbonate Substrate.**

by

Mukund Purushottam Patankar

Master of Science

In

Materials Science and Engineering

Stony Brook University

2010

The overmolding process involves the use of two separate materials to form one cohesive component. The final product is a single piece, made out of polymers with very different mechanical properties that must be safe and permanently bonded together throughout its useful life. The first shot is generally a hard plastic and is referred to as a substrate the second material is generally a soft thermoplastic elastomer (TPE) and referred as overmold. The rigid substrate is used for structural purposes, and the softer materials are expected to take care of the user comfort. Overmolding can add immeasurable value to product design by enhancing the comforts for user, ergonomics, and ease of use. It finds applications in household appliances, hand tools, automotive interiors, hand held computers and medical devices.

The most common problems with overmolding are insufficient chemical or mechanical bonding of the polymers, incomplete filling of one or more components, and flashing of overmold. This paper deals with adhesion issues and describes the study performed to evaluate the effect of processing parameters on adhesion performance of Polyether based TPU over mold on to Polycarbonate Substrate. The study established the effect of various processing parameters on the adhesion of overmold to substrate. In addition effect of various surface roughness of

substrate on adhesion was also determined. Study also describes the criteria used to design specimen and the specimen tool was build. The specimens were molded using design of experiments. The specimens were tested using Inston universal testing machine by establishing the test procedure and test set up to yield consistent results. The force at which constant peel occurred, called peel force was determined for all experiments. The study concludes that melt temperature is the most dominating factor and the specimen molded with lower melt temperature results in good bond. Light roughness on the substrate surface further enhances the adhesion. Scanning electron microscopy was performed on the peeled samples showed higher peel force and lower peel forces. The SEM images were thoroughly reviewed. It was further concluded that the air entrapment at higher melt temperature reduces adhesion. The main source for air entrapment is from the gassing of plasticizers, oils and waxes used in TPE formulations. The author also proposes similar studies for various other combinations of substrate and TPE as a path forward

Table of Contents

List of Tables -----	vi
List of Figures -----	vii
Acknowledgement -----	ix
1. Introduction -----	1
2. History of TPE -----	2
3. Thermoplastic Elastomer-- -----	3
4. Basic Principle of TPE -----	4
5. Types of TPE -----	8
6. Injection Molding of TPE -----	14
7. Overmold Considerations -----	17
8. Overmolding -----	18
9. Adhesion -----	25
10. Adhesion Mechanism -----	28
11. Adhesion Mechanism in Overmolding -----	32
12. Adhesion Studies -----	38
Background -----	38
Specimen Tool -----	38
Test Set Up -----	45
D.O.E. -----	50
13. Results and Discussions -----	54
14. Conclusion-----	65
15. Path Forward-----	71
Reference-----	72

List of Tables

1	Surface Energies	33
2	Parameters for DOE	51
3	Experiment Wise Processing Parameters	53
4	Summary of Results	57
5	Texture Roughness Values	58
6	Summary of Experiments Performed Best	65
7	Summary of Experiments Performed worst	66

List of Figures

1	Chemical Formula of Isoprene	2
2	Ionomer	4
3	SBS Structure	5
4	Block Copolymer	6
5	Polybutadiene Blocks.	6
6	Isotactic and Atactic Blocks	7
7	Elastomer Structure	7
8	TPU	9
9	Spandex	9
10	Dine Polymerization	11
11	Dine Polymerization	11
12	SBS Polymerization	12
13	Overmolded Part	21
14	Version 1 Part	22
15	Version 2 Part	23
16	Version 3 Part	24
17	Mechanical Lock	29
18	Diffusion	29
19	Surface Tension	33
20	Interphase	34
21	Effect of Solubility Parameter	35
22	Ionic Bond	36
23	Peel Test 180 Degree	39
24	Specimen	40
25	ASTM D1876	40
26	Roller Drum Peel Test	41

27	Test Set up	41
28	Specimen Model	42
29	Photograph of Specimen	44
30	Photograph of Specimen	44
31	Test Set Up	45
32	Photograph of Test Set Up	46
33	Typical Graph	47
34	Photograph of Display Showing Graph	48
35	Photograph of Test	49
36	Photograph of Peeled Specimen	50
37	Adhesive Bond	60
38	Cohesive Bond	60
39	SEM image of Expt.1 Substrate	61
40	EDS Spectra	62
41	SEM image of Expt.16 Substrate	62
42	SEM image of Expt.1 Substrate	63
43	SEM image of Expt.1 Overmold	63
44	SEM image of Expt.16 Overmold	64
45	DOE Results	68
Graph 1	Graph Summary of Results Batch 1	54
Graph 2	Graph Summary of Results Batch 2	55
Graph 3	Graph Summary of Results Batch 3	55
Graph 4	Graph Summary of Results Batch 4	56
Graph 5	Graph Experiment Vs Peel Force	57
Graph 6	Graph Summary of Texture	59

Acknowledgement

It is a pleasure to thank those who made this thesis possible such as God who gave me the wisdom, my mother who inspired me for continuing education, my wife who supported me and my daughters for their encouragement.

I am heartily thankful to my advisor, T. Venkatesh and my supervisor, Vik Bhargava, whose encouragement, guidance and support from the initial to the end enabled me to develop an understanding of the subject. Vik also directed me and participated in molding specimens and developing test setup.

I would also like to thank Paul Koehn and Bob Picoli for their support.

I would also like to thank Prof. Miriam Rafailovich, Prof. Jon Sokolov, Joe McFadden Sr, and my colleagues for their suggestions. I would like to thank Jim Quinn for his support for performing SEM. I might have missed mentioning some references especially from the world of web, I also would like to thank them for their contribution.

Lastly, I offer my regards and blessings to all of those who supported me in any respect during the completion of the project.

1. Introduction

Have you ever thought of how your fancy tooth brush or a screw driver handle is manufactured? The answer is overmolding. The overmolding process involves the use of two separate materials to form one cohesive component. Sequential overmolding or two-stage sequential overmolding is the process by which a rigid substrate is overmolded with a more flexible material. The final product is a single piece, made out of polymers with very different mechanical properties that must be safe and permanently bonded together throughout its useful life. This type of process is used for manufacturing parts where the rigid polymer is used for structural purposes, and the softer materials are expected to take care of the user comfort. Examples of such applications can be seen in telephone keypads, toothbrushes, shaving hardware, household appliances, hand tools, automotive interiors, hand held computers and medical devices.

Overmolding can add immeasurable value to product design by enhancing the end users experience in terms of comfort, ergonomics, and ease of use. A combination of novel material technology, part and tool design as well as innovations in overmolding technology will continue to fuel the imagination of the designer community to meet the ever demanding needs in ergonomics, aesthetics and value addition in the consumer market.

The overmolding process involves the use of two separate materials to form one cohesive component. The first shot is generally a hard plastic and is referred to as a substrate. There are wide varieties of substrate materials a few family names include PP, ABS, PC, PC-ABS, Nylons etc. Similarly the second material is generally soft thermoplastic elastomers (TPE) and referred as overmold. There are wide varieties of TPE families like Polyurethane, Styrenic Block Copolymers, thermoplastic polyolifienes, coplyesters etc. The industry is introducing broader spectrum of materials. This has expanded the opportunities for overmolding, simultaneously the expectations also grown. It is adding new level of complexity and poses new challenges in adhesion. That is the main focus of this study.

The objective of this study is to find out the effect of various processing parameters on the bonding performance of overmolded TPE on substrate. In this work one combination of material namely Polycarbonate Polysiloxane copolymer used for hard substrate and polyether based Polyurethane elastomer having hardness of 83 shore A used as overmold is evaluated.

Author has also covered briefly the related topics required to understand the issue of adhesion like types of TPE, injection molding of TPE, adhesion mechanism and types of overmolding processes. The introduction to hard plastic is excluded as it is known for years.

2. History of Thermoplastic Elastomer:

Natural rubber was first noted by Europeans in the 1490's in Central and South America through the discoveries of Christopher Columbus. Natural Rubber results from latex produced from Para rubber trees. In the 18th century, Charles Goodyear and Thomas Hancock discovered that heating natural rubber with sulfur resulted in a product that was not sticky or did not flow at elevated temperatures. This vulcanization process allowed entrepreneurs to manufacture and market a wide range of rubber products. The chemical structure of natural rubber can be seen in Figure 1. An increased price in natural rubber during the early 1900's led toward research to find a rubber that could be made in a laboratory.

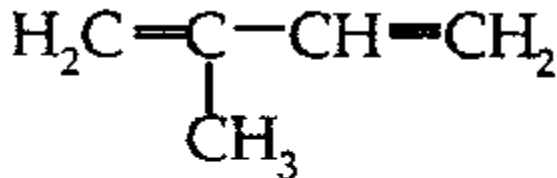

isoprene (2-methyl -1, 3-butadiene)

Figure 1

The first effort to develop synthetic rubber was performed in 1906 by Fritz Hofmann of Farbenfabriken vormals Friedrich Bayer & Co. (Now Bayer AG) in Germany. In 1911, synthetic rubber tires were produced for the limousines of German Princes. However, the synthetic rubber did not compare favorably with natural rubber. During WWI, a second effort was made with successful results. Production rates of synthetic rubber reached 136 metric tons per month throughout the length of the war.

3. Thermoplastic Elastomer (TPE):

Thermoplastic elastomers are a unique class of materials that combine the key processing and recycling properties of thermoplastics with many of the physical properties of thermoset rubbers such as elasticity, low compression set and high flexibility. In many aspects one can describe TPE as two phase materials consisting of a rubbery elastomeric component and thermoplastic rigid component. The elastomeric phase determines rubberlike properties such as elasticity, softness, flexibility, compression set and minimum service temperature. The rigid phase determines thermoplastic properties such as hardness, processability, recyclability and maximum service temperature.

The first commercial TPE's were thermoplastic polyurethanes (TPE_U) developed in Bayer laboratories. Over the years TPE product family and application areas grew significantly. Even today TPE's are one of the fastest growing polymer markets. We can classify thermoplastic elastomers into two main groups:

- Block copolymer based TPE's and
- Elastomer/Hard Polymer Blends.

Block copolymer can further be divided into two subdivisions; copolymers with amorphous rigid segments (styrenic block copolymers) and copolymers with crystalline rigid segments (polyurethanes, copolyesters, copolyamides). Elastomer/Hard Polymer blends also are further divided into blends where the elastomeric phase is not vulcanized (Thermoplastic Olifines or TPO) and blends where elastomeric phase is dynamically vulcanized during mixing (thermoplastic vulcanizate or TPV)

4. Basic principle of Thermoplastic Elastomer:

The idea behind thermoplastic elastomers is the notion of a reversible crosslink. Normal cross linked polymers cannot be recycled because they don't melt. They don't melt because the cross links tie all the polymer chains together, making it impossible for the material to flow. This is where the reversible crosslink comes in. In normal cross linking polymer chains bind together by covalent bond to form one molecule. The dissociation energy for covalent bonding is very high. The reversible crosslink uses non covalent or secondary interactions between the polymer chains to bind them together. These interactions include hydrogen bonding and ionic bonding. The beauty of using non covalent interactions to form crosslinks is that when the material is heated, the crosslinks are broken. This allows the material to be melt processed, and most importantly, recycled. When it cools the crosslinks reform again. Initially two approaches have been tried, ionomers and block copolymers.

Ionomer:

Ionomers are copolymers in which a small portion of the repeat units have ionic pendant groups attached to them. Normally the polymer backbone chain will be nonpolar. We all know the rule, like dissolves like. It works here, too. The nonpolar polymer backbone chains will group together, and the polar ionic pendant groups will cluster together. Now as much as the cluster of ionic groups, snobbish as they are, would like to separate themselves completely from the nonpolar backbone chains, they can't. Remember, they're just sort of attached to the backbone chains. So what ends up happening is that these clusters of ionic groups serve to tie the backbone chains together, just like a normal crosslink would.

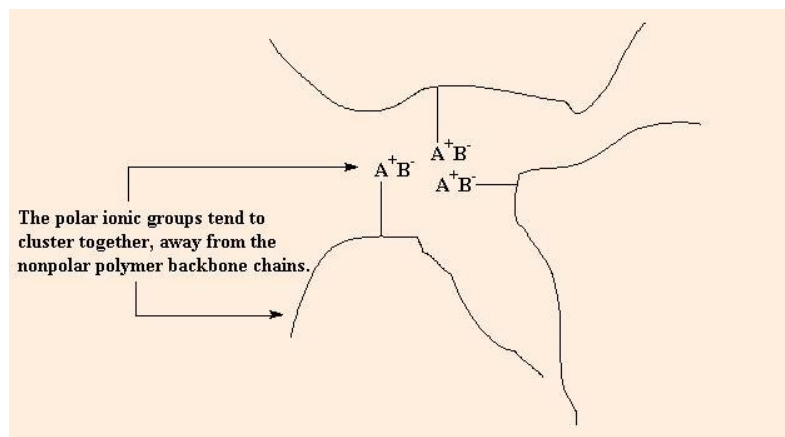

Figure 2

If ionomer is heated, the ionic clusters will break up. When molecules get hot, they move around more. To be sure, this motion of molecules is heat itself. Moving around like this at high temperatures makes it hard for the ionic groups to stay in their little clusters. So they break up. Now the ionomer has lost its crosslinks, and can be processed and recycled just like an ordinary polymer. When they cool it back the ionic clusters form again, and it acts like a cross linked polymer again.

Block Copolymer:

Thermoplastic elastomers can be made through a process called block copolymerization. A copolymer is a polymer made from more than one kind of monomer that is, made out of two or more co monomers. A block copolymer is a copolymer in which the co monomers are separated into long sections of the polymer backbone chain. Each of these sections, called blocks, looks like a homo polymer. Figure 3 shows SBS block copolymer.

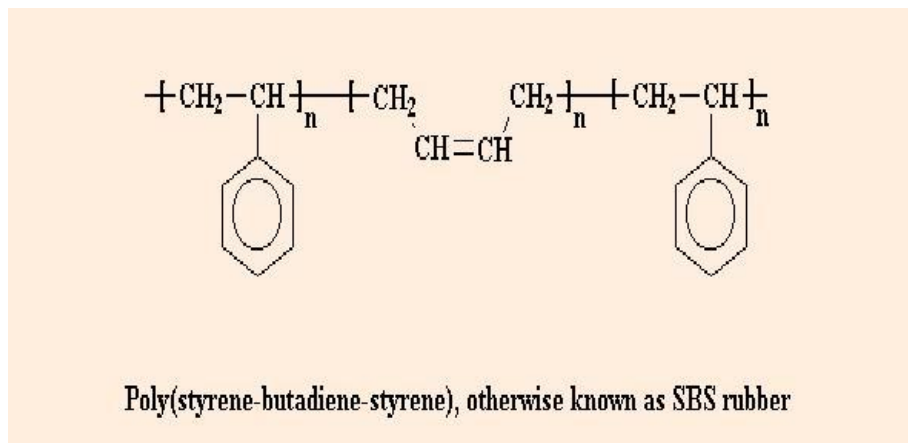

Figure 3

A very common thermoplastic elastomer that is a block copolymer is SBS rubber. SBS stands for styrene-butadiene-styrene, because SBS is made up of a short chain of polystyrene, followed by a long chain of poly butadiene, followed by another short chain of polystyrene. If we could stretch out a chain of SBS, it would look like the figure 4.

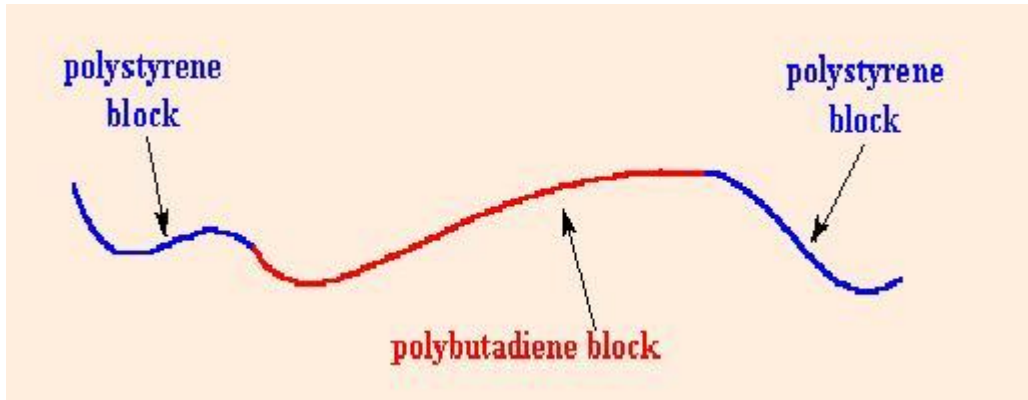

Figure 4

Different polymers don't mix very well. Remember the old "like dissolves like" rule. The polymers are even more snobbish than small molecules. It's very hard to mix two different polymers, even when they are very similar. This holds true for the blocks of SBS. The polystyrene blocks tend to clump together and the polybutadiene blocks tend to clump together. The clusters formed by the polystyrene blocks tie the polybutadiene blocks together. Each polybutadiene block has a polystyrene block at each end, and the different polystyrene blocks of the same SBS molecule aren't necessarily in the same cluster. This means that the different polystyrene clusters will be tied together by the polybutadiene blocks.

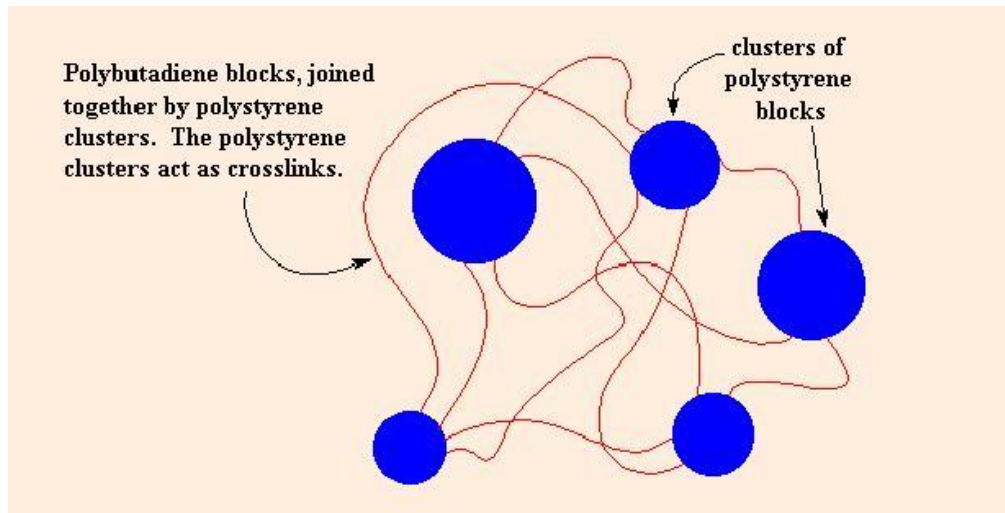

Figure 5

So the polystyrene clusters act as crosslinks for the polybutadiene blocks. And just like the ionic clusters of the ionomers, the polystyrene clusters break up when the SBS is heated, so it can be processed and recycled like a non-cross linked polymer.

You can also make a thermoplastic elastomer using a different tacticity.. You can make polypropylene in which there are blocks of different tacticity. One can make polypropylene with atactic blocks and isotactic blocks using metallocene catalysis polymerization like this. The result is shown in figure 6.

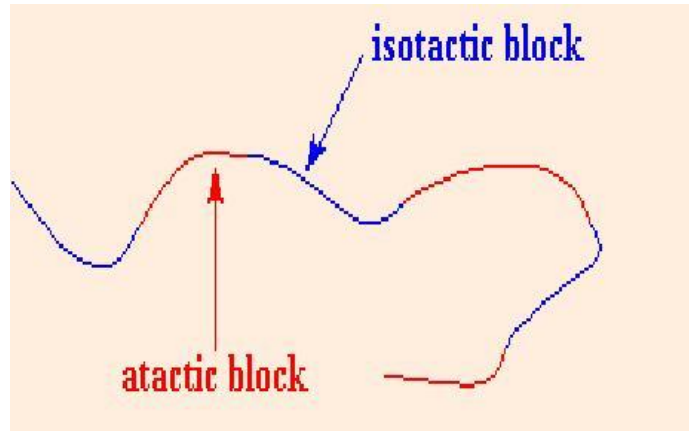

Figure 6

The blocks separate just as they do in SBS rubber. Isotactic arrangement is orderly arrangement and they can form crystals whereas atactic blocks are amorphous zones. They separate because the isotactic blocks will form crystals, but the atactic blocks are amorphous. The result is something that looks like the figure 7 as shown below. It behaves as an elastomer for the same reasons as SBS rubber does.

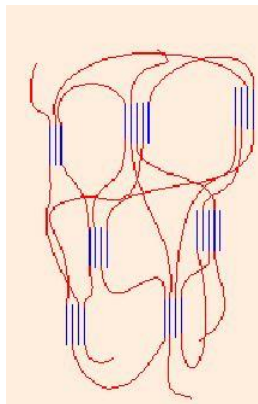

Figure 7

5. Types of TPE:

Now we have the background of structural details and about the mechanism of cross linking we will see a few important classes of TPEs in more details. It is not like one class is superior to other but it all depends on what properties are needed for particular application. The selection of TPE is purely application driven and the aim of describing these classes in details is to understand the structure, pros and cons of each type.

Thermoplastics Urethane (TPU):

Thermoplastic polyurethane, it is widely known as TPU is an elastomer that is fully thermoplastic. Like all thermoplastic elastomers, TPU is elastic and melt-processable. Further, it can be processed on extrusion as well as injection, blow and compression molding equipment. It can be vacuum-formed or solution-coated and is well suited for a wide variety of fabrication methodologies. TPU can even be colored through a number of processes. The currently available TPUs can be divided mainly into two groups, based on soft segment chemistry:

Polyester-based TPUs (mainly derived from adipic acid esters)

Polyether-based TPUs (mainly based on tetrahydrofuran (THF) ethers).

TPU is a linear segmented block copolymer composed of hard and soft segments. The hard segment can be either aromatic or aliphatic. Aromatic TPU's are based on isocyanates such as MDI while aliphatic TPU's are based on isocyanates like H12 MDI. When these isocyanates are combined with short-chain diols, they become the hard block. Normally it is aromatic, but when colors and clarity retention in sunlight exposure is a priority then aliphatic hard segment is often used. The simple PU can be made by reacting diol with diisocyanates. The chemical reaction for simple PU is shown in figure 8. PU structure can be as simple as shown below or as complicated as shown in figure 9.

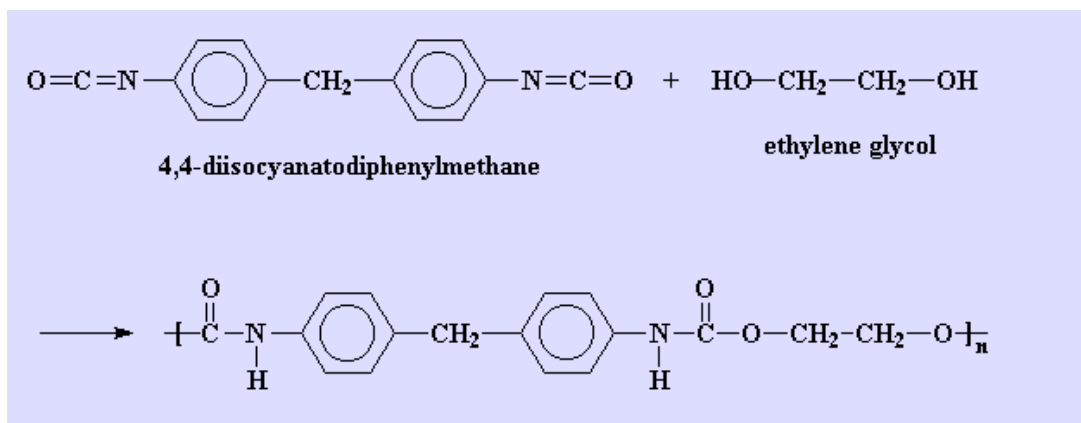

Figure 8

The Spandex structure is shown in figure 9. The Spandex is the special type of polyurethane contains urea linkage, urethane linkage and aromatic groups

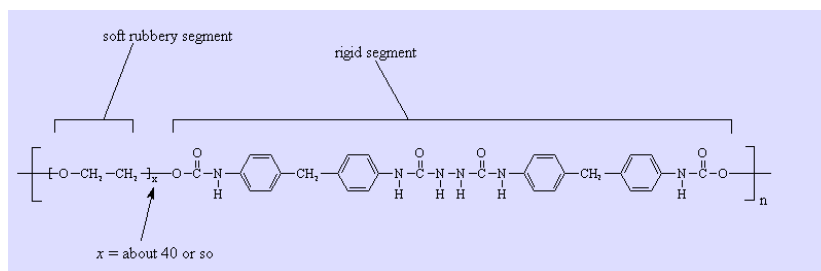

Figure 9

The soft segment can either be a polyether or polyester type. Again the selection is purely based on the application. For example, wet environments generally require a polyether-based TPU while oil and hydrocarbon resistance often demand a polyester-based TPU. This is mainly due to the polyether based TPU has better hydrolytic stability and Polyester based TPU has better resistance to oil and hydrocarbon. The molecular weight, ratio and chemical type of the hard and soft segments can be varied to achieve broad range of hardness and high elasticity without using plasticizers.

Mechanical properties of the polyester types are generally higher. Abrasion resistance of the urethanes is outstanding among all elastomers. This versatility results from the unique structure of TPU that results in high resilience, good compression set, higher impact strengths, abrasion resistance, tears, weather, and even hydrocarbons resistance. Among the features of commercially available TPU are:

- excellent abrasion resistance
- outstanding low-temperature performance
- excellent mechanical properties, combined with a rubber-like elasticity
- very good tear strength
- high elasticity
- high transparency
- good oil and grease resistance
- lower compression set

Styrene block copolymers (SBCs):

The styrenics are the lowest priced thermoplastic elastomers. They are block copolymers having an elastomeric center segment and polystyrene end segments. It should be noted that there are many possible block configurations of SBCs. There are three main possible center segments polymers in linear A-B-A configuration. A is polystyrene and B is following elastomeric segment

- Polybutadiene
- Polyisoprene
- Polyethylene-butylene

These center segments differentiate the three major styrene block copolymers (SBC):

- Poly(styrene-butadiene-styrene) (SBS)
- Poly(styrene-isoprene-styrene) (SIS)
- Poly(styrene-ethylene/butylene-styrene) (SEBS)

A fourth, much less common center segment, poly (ethylene/propylene), results in poly (styrene-ethylene/propylene-styrene) (SEPS). These elastomers are available in several molding and an extrusion grade ranging in hardness from 28 to 95 Shore A. Tensile strength of these materials is lower and elongation is higher than natural rubber, weather resistance is about the same. Other resistance characteristics can be improved by the addition of resins such as polypropylene or ethylene-vinyl acetate. The styrenic elastomers resist water, alcohols, and dilute alkalis and acids. They are soluble in, or are swelled by, strong acids, chlorinated solvents, esters, and ketones. One type has a service temperature limit of 150°F; another grade can be used to 250°F. Both have excellent low-temperature flexibility to -120°F.

Applications for the styrene-butadiene block copolymers include disposable medical products, food packaging, tubing, sheet, belting, mallet heads, and shoe soles. The unsaturated SBCs - SBS and SIS - are soft and flexible with excellent tack and adhesive properties. Hence, they tend to find use in adhesives (especially SIS), sealants and bitumen modification applications; footwear is also another important end-use for SBS on the basis of its softness and low cost.

Chemistry:

There is lot known about the processes in which SBCs are manufactured and some of them are discussed in following section. SBS and SIS polymers can be prepared by four different processes, each with unique characteristics:

- Difunctional initiator process
- Three-stage sequential addition process
- Coupling process
- Tapered block process

Linear A-B-A block copolymers can be produced via the use of difunctional initiators (e.g., sodium naphthalene or dilithium compounds). The initiation reaction follows the pattern shown below in figure 10

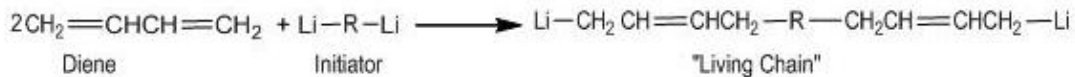

Figure 10

Diene polymerization then proceeds as shown in figure 11



Figure 11

Styrene is polymerised onto the diene block then proceeds as follows:

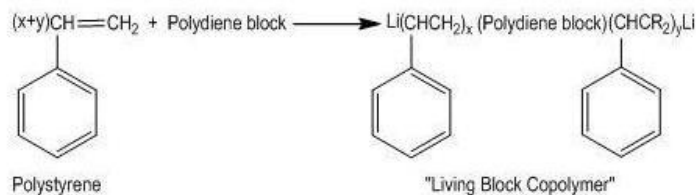

Figure 12

The resultant polymers can show a very narrow molecular weight distribution, but these initiators are generally only soluble in low polar solvents. As a result, the polydiene segment has a low 1,4 microstructure content which restricts the desirable property of low glass transition temperature. The wide range of physical properties which can be incorporated into the SBC polymer backbone, together with the great latitude in incorporating fillers, extenders, modifiers, or other additives into SBCs has enabled these materials to be used in a wide range of end-use applications.

Thermoplastic Olefins:

Thermoplastic olefin (TPO) elastomers are available in several grades, having room-temperature hardnesses ranging from 60 Shore A to 60 Shore D. These materials, being based on polyolefins, have the lowest specific gravities of all thermoplastic elastomers. They are uncured or have low levels of cross linking. Material cost is mid-range among the elastomer. The chemistry and manufacturing is same as that used for manufacturing any polyolefin's. These elastomers remain flexible down to -60°F and are not brittle at -90°F. They are autoclavable and can be used at service temperatures as high as 275°F in air. The TPOs have good resistance to some acids, most bases, many organic materials, butyl alcohol, ethyl acetate, formaldehyde, and nitrobenzene. They are attacked by chlorinated hydrocarbon solvents. Compounds rated V-0 by UL 94 methods are available.

Elastomeric alloys:

This class of thermoplastic elastomers consists of mixtures of two or more polymers that have received a proprietary treatment to give them properties significantly superior to those of simple blends of the same constituents. The two types of commercial elastomeric alloys are melt-processable rubbers (MPRs) and thermoplastic vulcanizates (TPVs). MPRs have a single-phase; TPVs have two phases. Thermoplastic vulcanizates are essentially a fine dispersion of highly vulcanized rubber in a continuous phase of a polyolefin. Critical to the properties of a TPV are the degree of vulcanization of the rubber and the fineness of its dispersion. The cross linking and fine dispersion of the rubber phase gives a TPV high tensile strength (1,100 to 3,900 psi), high elongation (375 to 600%), resistance to compression and tension set, oil resistance, and resistance to flex fatigue. TPVs have excellent resistance to attack by polar solvent and fair-to-good resistance to hydrocarbon solvent. Maximum service temperature is 275°F.

Elastomeric alloys are available in the 55A to 50D hardness range, with ultimate tensile strengths ranging from 800 to 4,000 psi. Specific gravity of MPRs is 1.2 to 1.3; TPV's range is 0.9 to 1.0. In 1981, Monsanto Chemical Co. commercialized a line of TPVs, called Santoprene, based on EPDM rubber and polypropylene, designed to compete with thermoset rubbers in the middle performance range. There are grades available based on polypropylene and nitrile rubber. This TPV alloy was designed to provide greater oil resistance than that of the EPDM-based material. The nitrile-based TPV provides a thermoplastic replacement for thermoset nitrile and neoprene because oil resistance of the materials is comparable.

The MPR is a single-phase material, which gives it a stress-strain behavior similar to that of conventional thermoset rubbers. MPRs are plasticized alloys of partially crosslinked ethylene inter polymers and chlorinated polyolefins. These materials have excellent oil and weather resistance. Maximum recommended service temperature is 275°F. It is available in hardnesses from 55A to 80A. Unlike other TPEs, it can be processed on rubber equipment as well as on conventional thermoplastic equipment. Several injection-molding grades are now available. Commercial applications of elastomeric alloys include automotive protective boots, hose covering, electrical insulation, seals, gaskets, medical tubing and syringe plungers, architectural glazing seals, and roofing sheet.

Copolyesters:

These thermoplastic elastomers are generally tougher over a broader temperature range than the urethanes. Also, they are easier and more forgiving in processing. Several grades are produced by Du Pont (Hytrel), Hoechst-Celanese (Riteflex), and Eastman Chemicals (Ecdel), ranging in hardness from 35 to 72 Shore D. These materials can be processed by injection molding, extrusion, rotational molding, flow molding, thermoforming, and melt casting. Powders are also available

Copolyesters are high-priced elastoplastics, have excellent dynamic properties, high modulus, good elongation, tear strength, and good resistance to flex fatigue at both low and high temperatures. Brittle temperature is below -90°F, and modulus at -40°F is only slightly higher than at room temperature. They have higher heat resistance up to 300°F. Resistance of the copolyesters to nonoxidizing acids, some aliphatic hydrocarbons, aromatic fuels, sour gases, alkaline solutions, hydraulic fluids, and hot oils is good to excellent. Thus, they compete with rubbers such as nitriles, epichlorohydrins, and polyacrylates. However, hot polar materials, strong mineral acids and bases, chlorinated solvents, phenols, and cresols degrade the polyesters. Weathering resistance is low but can be improved considerably by compounding UV stabilizers or carbon blacks with the resin.

Copolyester elastomers are not direct substitutes for rubber in existing designs. Rather, such parts must be redesigned to use the higher strength and modulus, and to operate within the elastic limit. Thinner sections can usually be used typically one-half to one-sixth that of a rubber part. Applications of copolyester elastomers include hydraulic hose, fire hose, power-transmission belts, flexible couplings, diaphragms, gears, protective boots, seals, oil-field parts, sports-shoe soles, wire and cable insulation, fiber-optic jacketing, electrical connectors, fasteners, knobs, and bushings.

6. Molding of Thermoplastic Elastomers:

A first consideration in injection molding of TPEs is that the rheological properties, the rheological properties of almost all the TPE's are different from those of most thermoplastic materials. Since all TPE's are quite rubbery in nature, the viscosity of the materials is generally more sensitive to shear than temperature. As the material experiences higher shear rates, the viscosity decrease becomes more dramatic. As a result of this shear sensitivity, it is very important to measure/monitor the resin's melt viscosity at a variety of shear rates with a capillary rheometer unit prior to molding. Because of this viscosity sensitivity, in line reciprocating type injection molding machines should be utilized whenever possible since shear rates can be more easily controlled. We will see the processing consideration for main classes of TPE as follows.

Polyurethane Elastomers:

A wide variety of thermoplastic polyurethane elastomers (TPU's) are available, with hardness values that range from 50 Shore A to 90 Shore D. As discussed earlier the TPUs are available in two classes. The polyester based TPUs have higher tensile strength and better resistance to ozone, oxygen, oil, and solvents than the polyether type TPU's. However, the ether-based TPE's have better low temperature properties and better resistance to hydrolysis and microbial attack. Both classes have similar processing conditions. The material is hygroscopic, and must be dried prior to processing 0.05% to prevent loss in molecular weight and physical properties. A mold temperature of between 90°F and 150°F is sufficient for optimum surface appearance and physical properties. When the material is processed correctly, the melt should appear slightly off-white to a very light yellow color. If the melt contains bubbles, then moisture is probably present. Excessive melt temperatures will result in a "very transparent" purge shot and sticking to the mold cavities. During shutdown, the barrel should be purged clean with a material such as polyethylene or polystyrene to prevent possible degradation of the material that remains in the barrel. Generally, the TPU's are quite easy to mold if the material is dry and proper melt temperatures are maintained. Also, it is important to note that most polyurethane do not achieve their ultimate properties for several days. This is due to their rearrangement and ordering of their crystalline structure over a period of time. Toughness and lower compression set can be improved if the parts are annealed at 200°F for 8 to 10 hours. Their major applications include automotive parts, caster wheels, and industrial goods such as drive belts, soft-faced hammer heads and gaskets.

SBC group:

SBCs were introduced in mid sixties and offer the end user the widest range of overall elastomeric properties. Durometers as low as 3 Shore A and as high as 70 Shore D have been molded successfully over the years. The styrenic TPE's are commercially available as two different classes depending upon the midblock composition discussed earlier. Generally, the unsaturated styrenic materials (styrene-butadiene-styrene, SBS) do not require excessively high shear rates. However, the saturated midblock types (styrene-ethylene-butylene-styrene, SEBS) require higher shear rates during plastication to ensure adequate surface appearance and good physical properties. The cylinder temperatures for the unsaturated materials should range from 280°F to 400°F, depending upon the grade of material. Generally, higher mold temperatures will result in a better surface appearance. The injection pressures for the unsaturated styrenics can range from as low as 3000 psi to as high as 20,000 psi depending upon the flow path to thickness ratio of the part and processing conditions. The hold time should be as short as possible so that over packing of the part will not occur. The rate of injection should be from slow to moderate depending upon runner lengths and part size. Normal screw speeds of 30 to 80 rpm should be used. Back pressures of 250 to 500 psi (melt pressure) should be sufficient for developing a homogeneous melt. The saturated styrenics have somewhat more processing stability and therefore are more forgiving. This is due to the absence of the double bonds found in the unsaturated styrenics (SBS). The cylinder temperatures for these materials are generally from 380°F to 500°F with mold temperatures of 80°F to 175°F. The injection rate should be fast so that freeze-off will not occur and surface appearance will be optimized. The screw speed and back pressure can be somewhat higher than the unsaturated styrenics, depending upon the compound formulation. Since styrenic TPE's can be quite soft in durometer, over packing the mold cavity should be avoided for easy processing. Applications for molded items include footwear, automotive goods, medical items, and general purpose consumer items.

Thermoplastic Polyolefins:

The thermoplastic polyolefin elastomers (TPO's) are the fastest growing TPEs. They can be manufactured using various olefinic based polymers and compounding technology, offer a wide range of processing characteristics and physical properties. The polyolefin elastomers or TPO's can be separated into three distinct classes depending upon their particular morphology. Their hardness ranges from 35 A to 65 D.

1. Earlier TPO's, they were produced by mechanical blending of olefinic materials like polyethylene, polypropylene, and EPDM.
2. Thermoplastic vulcanizate (TPV) consists of a blend produced through a compounding process that partially cures the elastomeric phase within a thermoplastic carrier.
3. Melt Processable Rubber. They are the latest and a single phase olefinic elastomer. They exhibit a single glass transition temperature.

These three classes of materials behave in a somewhat similar manner during the molding process. The TPV's tend to "set up" faster because of their partially cured elastomer phase and

therefore will generally result in faster cycle times. The barrel temperatures should vary from 375°F to 450°F, depending upon the grade of material. The mold temperatures can be from as low as 35°F for some grades to as high as 175°F. The injection rates should be from moderate to fast to ensure adequate filling. The TPO's do not readily absorb water, but they should be stored in a relatively dry area. If the materials become wet, or are exposed to ambient conditions for a long time, they should be dried at a maximum temperature of 200°F for 1 to 3 hours. Although the TPO's exhibit more elasticity in the melt than typical olefins, they are very similar in processing characteristics. The major applications include many different automotive items such as exterior body parts, body side molding, air ducts, and industrial goods.

Copolyester Elastomers:

The copolyester elastomers offer the molder a class of materials that exhibit physical properties that are between those of an elastomer and an engineering thermoplastic. They offer excellent flexibility, resistance to creep, and are operational over a broad temperature range. These copolyester elastomers must be dry before molding for optimum properties to a moisture level 0.1%. In general, the copolyesters are not as shear sensitive as some of the other classes of TPE's. Their viscosity can be more easily controlled by increasing or decreasing barrel temperatures. Injection pressures as low as 3000 psi can be used when mold temperatures are hot enough (150°F). Higher pressures will reduce shrinkage because of the higher packing. The injection rates should be high for thin walled moldings, while a moderate rate for thicker sections will be sufficient. Their major applications include automotive items such as constant velocity drive joint boots, electrical components, and "living hinge" products.

7. Overmold Considerations:

- All the TPE's commercially available today may be molded quite easily in many conventionally designed molds.
- Processing the softer durometer compounds ~45 A will sometimes require a modified sprue design that will allow for easier removal.
- Draft angles of 3.0° are generally satisfactory for most of the softer compounds.
- More "aggressive" sprue puller pins are sometimes required in order to increase the pulling force.
- For deeper draw and softer compounds, a stripper plate and/or air poppet may be required to break the vacuum that can be created by shrinkage.
- Ejector pins should also be as large as possible so that they will not penetrate through the part.
- The runners should be of a full round configuration and as short as possible so that adequate flow will occur on all shots.
- Gate sizes should always begin small (the size depends upon the part) and enlarged when necessary.
- If the gate is too large, chunks of material may be pulled out of the part when the gate is separated.
- In most cases, the mold cavity surfaces should be vapor honed for optimum release from the cavity.
- Highly polished or chrome plated mold surfaces can cause sticking and are not recommended especially for the softer materials.
- Hot runners are being successfully used in systems that have runner diameters greater than 0.05 inch and are "fairly short."

8. Overmolding:

This is also called multicomponent or two shot molding. This can be achieved by two methodologies, insert molding and sequential molding. Sequential injection overmolding is the process by which a rigid substrate is overmolded with a more flexible material. In a single mold with two or more inlets, and moving parts that allow sequential entrance of melts into different sections of a main cavity, two or more types of thermoplastic polymers are sequentially injected. The final product is a single piece, made of polymers with very different mechanical properties that must be secured and permanently bonded together. It has drastically changed the aesthetics, design, and functionality of consumer products over the last decade

This type of process is used for manufacturing multi-component applications, where the rigid polymer is used for structural purposes, and the softer materials are expected to take care of the user's comfort or to repeatedly admit larger deformations without noticeable damage. Examples of such applications can be seen in telephone keypads, toothbrushes, shaving systems, household appliances, hand tools, automotive interiors, and medical devices. In overmolding applications, an overmold is injection molded around, over, under, or through a substrate material to complete the final part. This injection can be done with multi shot process or by insert molding. Usually, the overmolded material is an elastomeric resin.

Over molding reduces the cycle time required to produce multifunctional components. Rather than manufacture individual parts that require assembly, the subassembly is produced in the machine. This eliminates handling and improves output and productivity. This process enables the designer to tailor performance of a part by utilizing specific properties of different materials. Producing two shot parts on one machine eliminates handling between processes, the possibility of losses in transit, in-handling damage, and losses during assembly. It also reduces the amount of floor space required by eliminating multiple machines, parts staging, and assembly areas.

The primary disadvantage of multicomponent molding is the cost. Both machines and mold are more complex and more expensive. Machines involving sliding or 360-degree rotary platens are significantly more expensive. As a result, it is essential that production volume for overmolding application is high enough to support this investment.

Multishot molding process requires a special press with two or more barrels so that different resins can be shot into the same injection molding tool. The barrels arranged parallel to each other or in an L configuration, feed resin through common or separate injection points into the tool. When one common injection point is used, the process is called coinjection, and the result is a composite part in which a skin encapsulates a core resin. Separate injection points result in an overmolded part, which is produced by molding one component on top of the other, creating a layered structure.

Multishot molding is not possible for all products. The required thickness of the overmold must be able to be created by moving a slide or by rotating the mold core to another

mold cavity. The other option involves shuttling the molded core to another press. This is called insert molding. A product such as a completely overmolded handle would require insert molding. To be completely overmolded, a substrate must be taken out of the tool and placed into a different core and cavity to create the volume for the overmold material. During this process, a separate tool should run in the same or a different-size press depending on shot size. Usually preheating the substrate might be necessary to bring its surface temperature closer to the melt temperature of the overmold, so as to reach optimum bond strength. This aspect of using hot substrate also studied in this paper.

Sometimes overmolding is also called in-mold assembly, since the resulting part essentially assembles two materials rather than creating a layered structure. Both individual components and assemblies can be overmolded. But regardless of the application, achieving a mechanical or chemical bond between the substrate material and the overmolded component is crucial.

Now let us see the main overmolding processes popular currently. We will focus our discussions on the description of equipment, process and transport mechanism.

Insert Molding:

The substrate is molded first and transported to other press, inserted into the tool and overmolded with TPE or any other material

Injection Molding Machines

Two separate regular injection molding machines are used for this process. Both injection units are capable of filling at the same time to two different positions in the mold.

Molds

The process requires two separate molds. The substrates are generally molded first or as first shot parts moved to a new location for second shot. This allows cavities for second shot to be totally different than first shot.

Process

Robot picks part off of first shot and relocates part onto second shot location.

Advantages

- Simpler design and simpler tool
- Process flexibility
- Better thermal management is possible in tool this can be explained as follows, assume TPU is overmolded on PC/ABS substrate. In this case, substrate needs 70 to 90 deg C of mold temperature and overmolded TPU needs 30 to 50 deg C of mold temperature, in insert molding two separate tools are used this can be easily achieved but in case of rotary platen thermal management becomes a big challenge. Achieving required mold temperature for substrate and overmold becomes too tough and needs insulation between the two cores.
- One-time capital cost.

Disadvantages

- For complicated design of substrate the robot may not be able to place or force the part onto a second shot tool. This needs additional labor.

- Generally, higher scrap rates result because of handling and transportation of substrate.
- If it is done on separate presses, this process needs proper scheduling. Here two presses are linked together
- Contamination of substrate during storage or transportation may results in adhesion issues.

Rotary Platen:

The rotating platen is mostly used for over-molding applications where the core would stay the same for both first and second shot. After first shot is molded the mold opens up, then the complete ejector half of the mold rotates 180 degrees, then the mold closes and second shot is molded over the top of first shot. This is typical for most of the over-mold and soft touch applications.

Injection Molding Machines

IM machine for this process needs two plasticizing units; bigger platens two hold molds with both substrate and overmold core and cavities. Rotating platen is generally a function of the machine. Basically it is a turntable, a rotating plate mounted on or in the moving platen of the press. On some machines, it is an integrated part of the press and the platen is machined to accommodate the rotating mechanisms. On smaller presses, it may be a separate transmission housing bolted onto the moving platen.

Advantages

- Since transportation of substrate is not required no additional labor cost is associated.
- Scheduling flexibility
- Higher yield.

Disadvantages

- Complicated tool.
- Expensive molds
- The parts that require the new core underneath first shot can't be molded with this process.

Rotating Sleeve:

This is also called indexing plate. This is used when the overmold or second shot requires new feature on core. Generally it is a function of the mold. The shaft is located in the center of the ejector half of the mold. This shaft lifts and rotates the stripper plate. This shaft attaches to the back side of the stripper plate, opposite the parting line and goes through the "B" plate, any support plates, ejector housing and machine's platen. The other end of the shaft may or may not be attached to the machine's knock-out plate. The press knock-outs move the stripper plate forward. The center shaft then is rotated by either hydraulic motor or a rack and pinion mechanism.

After lifting first shot off of the core with a stripper plate, you can rotate and relocate first shot onto a new core at the second shot position to create new geometry or new coring detail.

Advantages

- Rotary stripper plates are used when the part requires a new core for second shot.
- No need of Rotary platen

Disadvantages:

- Too complicated tool design
- Expensive tooling.
- Limited use

In order to understand the concepts explained above and the different versions of tooling needed to full fill the requirements let us consider one example and develop concept for the above three techniques discussed.

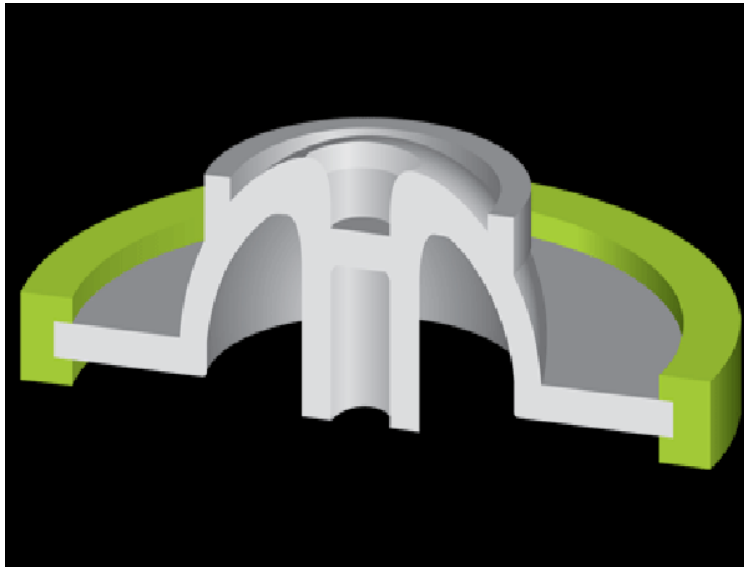

Figure 13

Consider a circular part with a diameter of twenty centimeters. The part is shown in figure 13. The gray portion is the first shot and the green portion is second shot. Now we will try to duplicate this part using three alternates explained. First shot on all versions will be the same. Second shot has the criteria that the material to be on top, on the side, below and underneath the part.

Version 1 Insert Molding:

First shot is molded in a separate tool showed by left side of the figure 14. The part moved to second tool and second shot is overmolded on first. This is captured in a right side of figure 14. Two separate tools so no complications.

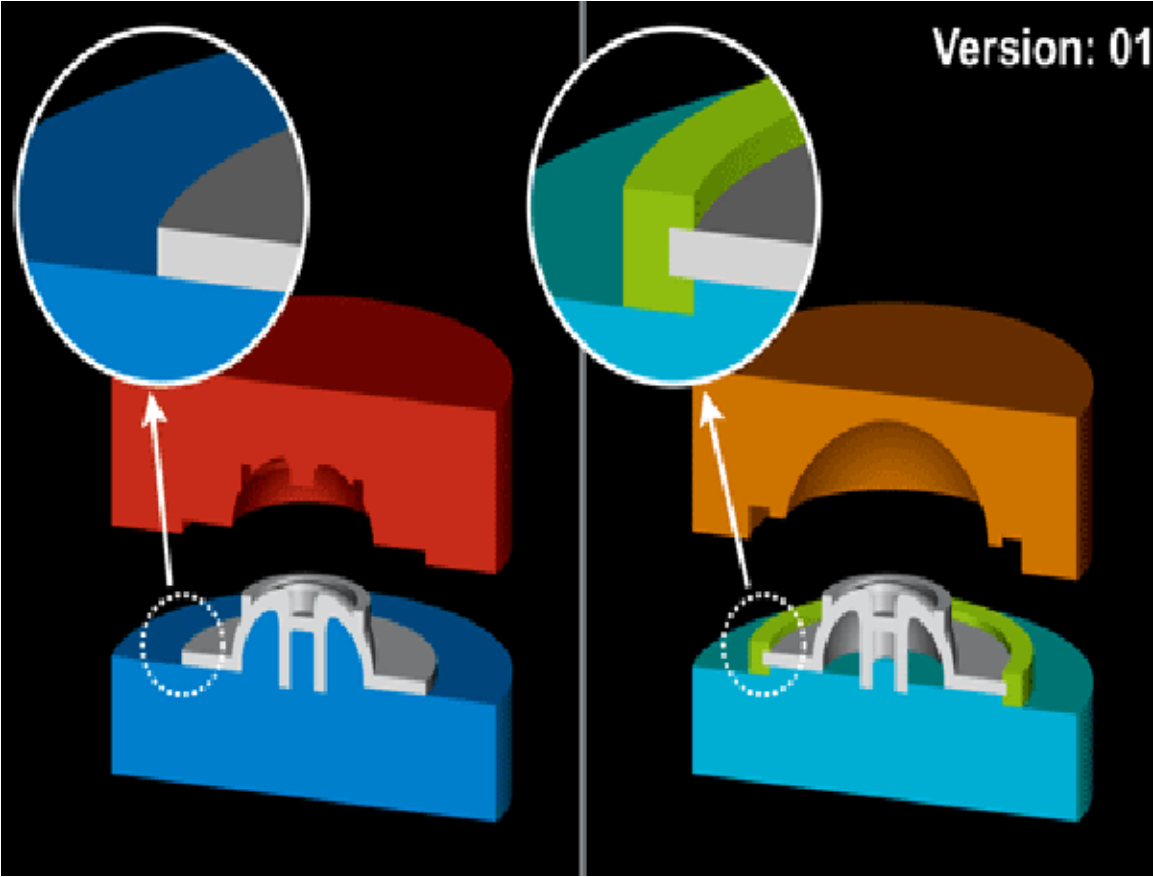

Figure 14

Version 2 Rotary Platen:

In this the core for both first and second shot is common. There are different cavities and different slide actions on this part. The outside of the part here is being molded by slides that are attached to the "A" half. On the first shot, the slides are only there to create space for the slides that are required for second shot slides. This is shown in figure 15 below

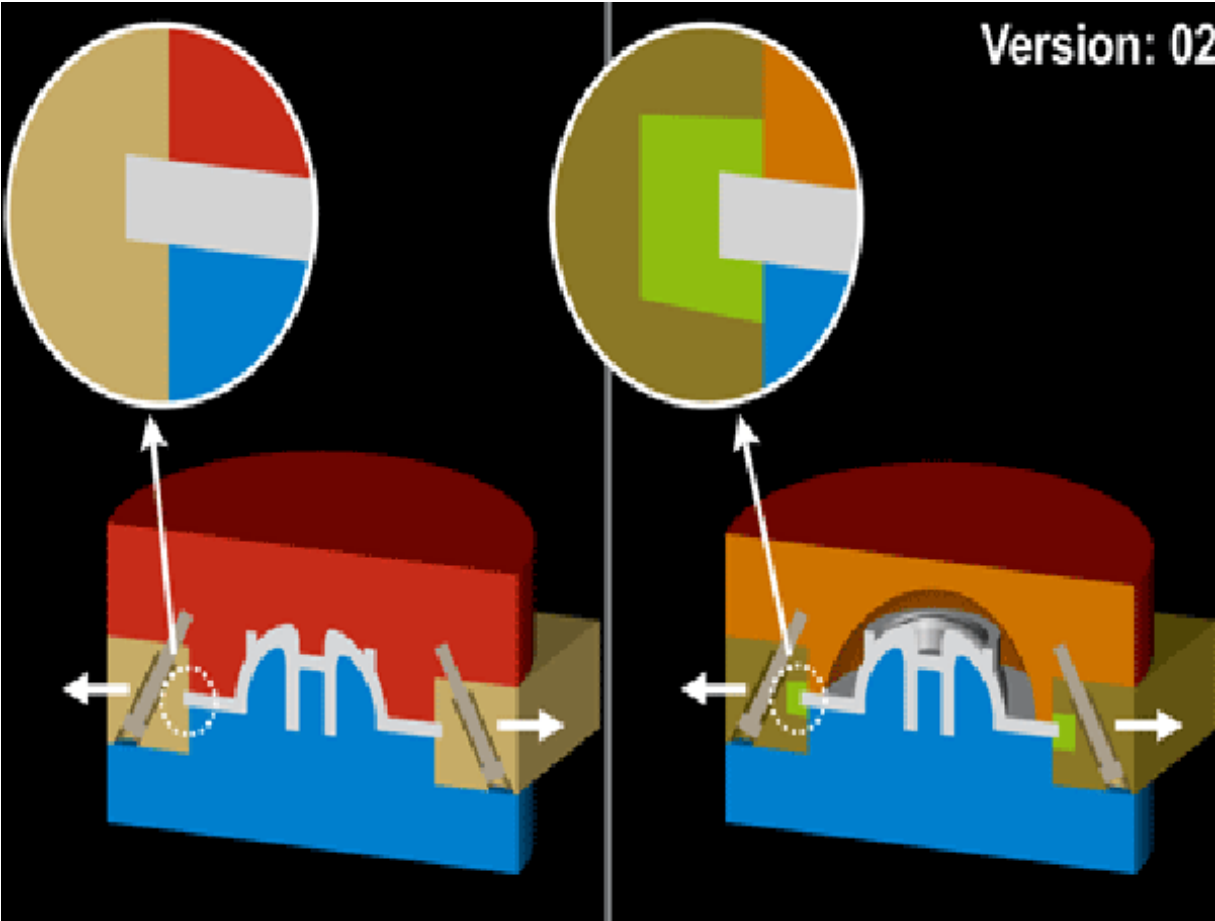

Figure 15

Version 3 Rotating Sleeve:

This version is using a lifting and rotating stripper plate. As the drawing shows, a two-piece stripper plate allows for a core to float between these two plates. The core is trapped between these plate and limited in travel by the head on this core. The static flush and static advancing blocks will set the appropriate height for the core. The static flush and static advancing blocks are attached to the static "B" plate. This floating core, when raised at the second shot location allows for second shot material to be fed below and underneath the part. This is shown in figure 16

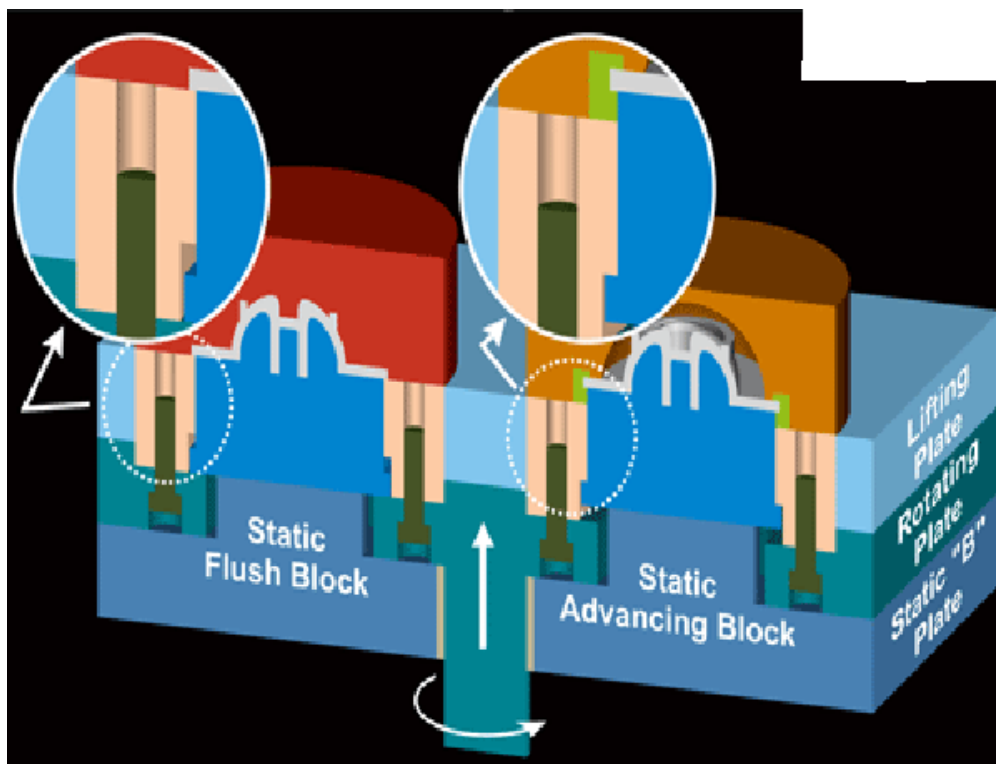

Figure 16

Overall there are lots of developments in overmolding technologies and various options are available. No option is good or bad. The best option is chosen based on the design, part quantity required and the investment available.

9. Adhesion:

Over the past decade, soft-touch overmolding has radically changed the look, feel, and function of a broad range of consumer products. Abundant new color, texture, and tactile options are available in such products as toothbrushes, razors, power tools, cameras, kitchen items, hand-held electronics, and auto-interior parts. Regardless of the process used, molders face the same challenges in achieving high part quality. The most common problems with any multi-material process are

- Insufficient chemical or mechanical bonding of the polymers,
- Incomplete filling of one or more components, and
- Flashing of overmold

These conditions can occur irrespective of whether the materials combination is reinforced and unreinforced, solid and foamed, rigid and soft, virgin and regrind, pigmented and unpigmented, etc. Multi-material molding, its problems and solutions are a complex subject that cannot be explored thoroughly in a short study like this. A critical challenge for designers and molders of these parts is poor adhesion of TPE to substrate, which reveals itself in peeling, curling, fraying, or delamination of the material layers. Initially, this was a fairly straightforward issue since the most common approach was to combine an olefin-based TPE with a compatible rigid PP substrate. In recent years the number of TPEs used in overmolding has expanded significantly to include more TPE classes like TPU, SEBS, TPV and others with a broader range of substrates like ABS, PC, and Nylons. While the broader materials spectrum for overmolding expands opportunities for soft-touch design, it also adds new levels of complexity and poses new challenges in adhesion. Adhesion performance is also affected by a number of additional factors. A few of them mentioned briefly here:

Melt temperature:

Selecting a target melt temperature for the TPE depends on the substrate and the adhesion level required. Most TPE suppliers provide a recommended range of melt temperatures for their products. The general understanding is for maximum adhesion, aim towards the upper end of the supplier's recommended range. Higher the temperature betters the bond however our observation with PC and TPU was not so clear. Researching further some people do believe in optimizing the temperature by gradually increasing from low to high and then selecting the best based on the testing data received for that product. There are possible adverse effect of higher melt temperature that is thermal degradation and gassing or leaching out of volatiles.

Substrate preparation:

This is mostly applicable for insert molding. Proper preparation and handling of inserts is critical to adhesion performance. The cleaner the insert, better it bonds. The optimal production method is to overmold inserts directly after they are produced, since that minimizes chances of contaminants collecting on the insert surface. Also, mold releases are best avoided since they seriously impair bond strength between TPE and substrate. Preheating inserts prior to overmolding often improves adhesion strength. The extent of improvement depends on the degree of compatibility between insert material and TPE. The appropriate insert temperature depends on the substrate and TPE and is best determined through discussions with the materials suppliers.

Shut-off design:

Design of the transition, or shut-off, area between the TPE and substrate is critical to adhesion. Designs should avoid “feathering,” or gradual thinning of the overmolded TPE. Thin layers cause inadequate bonding and can result in curling or fraying of the TPE layer at the tapered edges. Ideally, a uniform TPE layer thickness of around 0.04 in. is desirable for good adhesion, but that is not always feasible.

Vent design:

Air entrapment in the cavity during TPE overmolding is also detrimental to adhesion and is best addressed by adequate venting in the tool. Insufficient venting can show up as poor adhesion at the end-of-flow points, scorching of the TPE, or even short shots. Typical vent depths are between 0.0005 and 0.001 in. The right vent depth for a given part depends partly on the flow properties of the TPE involved.

Texture:

Adding texturing along the interface between materials can also help by increasing the surface area, but it may also lead to trapped air bubbles that reduce adhesion.

Impurities:

The main sources of impurity to pure polymer matrix are addition of various additives impact modifiers, colorants and fillers. They may cause reduced adhesion some of the additives like mold release or lubricant in processing aids form a thin film on the surface reducing the interaction of substrate and TPE causing the weak bond.

Mold temperature:

Mold temperature is another important factor. Accurate control of the temperature is mandatory when running molds with core lifters for the second shot. Incorrect mold temperature

can cause a lifter to wedge or jam, because of differential thermal expansion of the steel or steel/brass combination.

Injection time:

Generally TPEs are very shear sensitive materials and viscosity drops down quickly increasing shear rate at higher shear. High shear increases the friction between the different layers of material creating frictional heat and reduce the viscosity. The lower viscosity may increase the wetting resulting in a good bond

Overall lot of information is available on the processing parameters that influence adhesion or bond between TPEs and substrate. The influence of the parameters also depends on the combination of substrate and TPE being molded.

Let us try to understand the science behind adhesion. In following section we will focus on adhesion and its mechanism related to our subject.

10. Adhesion Mechanism:

Adhesion is defined by the state that two bodies are hold together for an extended period by interfacial forces. The forces range from valance forces to mechanical interactions.

Overall to understand adhesion one has to consider following things

1. Surface science
2. Polymer Characteristics
3. Interactions between polymers and surfaces

For years many workers researched on the work of adhesion, because of the wide range of interfacial adhesion, many theories were developed to describe the phenomena. The theories of adhesion have been classified into four main categories. The appropriate theory must be selected based on chemical adhesive/ adherent combinations.

Four mechanism of adhesion:

1. Mechanical Interlocking
2. Diffusion Theory
3. Adsorption and Surface Reaction
4. Electrostatic

Mechanical Interlocking:

This is the oldest theory. The theory essentially described that mechanical interlocking of the adhesives and the flow into the irregularity of the substrate surface is the source of adhesion. One good example is in the case of dental restoration. Dentist drills out the tooth material to create a pit with an undercut angle of around 5 degree. The adhesives have to flow into the pores and interstices of the materials to establish mechanical embedding. The embedded adhesives solidify and become in extractable.

The best example to explain this in relation to over molding is locking feature provided on substrate in which TPE will flow and provide a mechanical lock. The limitation of this is lower pull out force exhibited by relatively softer elastomer.

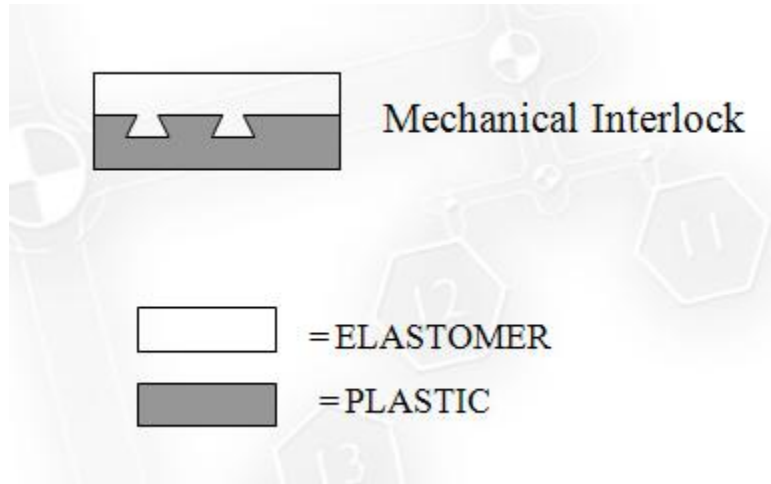
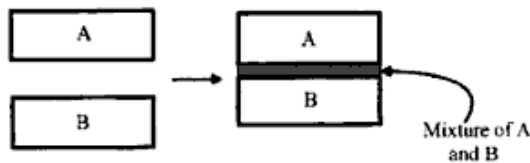

Figure 17

Diffusion Theory:

The Diffusion theory states that adhesion occurs through inter-diffusion of the adhesive and adherent across the interface. Adhesion is considered a three-dimensional volume process rather than a two-dimensional surface process. The Diffusion Theory applies particularly to polymeric materials where physical entanglement is common. In order for interfacial diffusion to occur, the adhesives and adherent must be thermodynamically compatible to each other.

Assume material A and material B is soluble in each other. When the two materials brought in contact they dissolved in each other and as a result of diffusion they form an interphase which is solution of both. They no longer have interface but they have interphase. Refer figure 18 explaining the concept.



If material A and material B are at all soluble in one another, they dissolve in one another and form an interphase which is a solution of material A in material B and vice versa. This schematically shows diffusive bonding.

Figure18

One criterion for good adhesion using diffusion theory is solubility parameter (δ) which provides a numerical estimate of the degree of interaction between materials, and can be a good indication of solubility, particularly for non polar materials such as many polymers. Materials with similar values of δ are likely to be miscible. It is given by following equation.

$$\delta = \sqrt{\frac{\Delta H_v - RT}{V_m}}$$

Where

ΔH_v = Heat of vaporization

(δ) = Solubility parameter

V_m = Molar volume

R= gas constant

T= temperature in deg K

The situation in which adhesive and adherent is soluble in each other is rare therefore the this theory has limited applications

Adsorption and surface reaction:

The adsorption theory is the most widely applied theory on interfacial adhesion. The theory states that surface forces are involved in adhesion, and that polar molecules are oriented in an ordered way so that surface molecules of adhesive and adherent are in contact. Sufficient intimate molecular contact is achieved at the interface that the materials will adhere because of inter-atomic and intermolecular forces.

Wetting is the initial physical process occurring in interfacial bonding. Substrates with low surface free energies are difficult to get wet. To facilitate the flow of adhesives, techniques such as etching are applied to increase the surface free energies. Common techniques used are plasma etching or acid etching. While plasma etching is commonly used for the surface of plastics, acid etching is sometimes applied in the case of metal. For example, stainless steel used as coronary stent may be pretreated with acid before a layer of coating is applied.

Electrostatic Theory:

The theory describes that an electrical double layer is produced at any interface and the consequence coulombic attraction largely accounts for adhesion and resistance to separation. The

theory can be viewed as treating the adhesives/substrate system as a capacitor that is charged due to contact of the two different materials. The Deryaguin's Theory as shown below can be used to represent the Electrostatic Theory,

$$A_c = \frac{h_c \epsilon_d}{8\pi} \left(\frac{dV_c}{dh_c} \right)^2$$

Where

A_c = energy required to separate interphase

V_c = discharge potential at the discharge gap

h_c and ϵ_d are the dielectric constants.

A common example often described by the Electrostatic Theory is the adhesion of a plastic film on a layer of paper or another film of plastic. This type of interaction is rarely seen in TPE overmolding, although it is effective.

11. Adhesion Mechanism in overmolding:

We have seen the adhesion mechanism in general mainly used in adhesive bonding now we will focus more on its application in overmolding. We have seen earlier that TPE enjoys the advantage of being an elastomer that can be processed in conventional machinery that is used for thermoplastic resins. One unique group and very broad applications for TPEs, especially the soft TPEs have been for over-molding onto rigid substrates. Binding TPEs onto polymeric substrate can best be accomplished through injection molding or co-extrusion. The adhesion process can be separated into three basic steps:

1. Wetting of the substrate surface by the TPE melt
2. Diffusion of TPE molecules into substrate bulk
3. Setting or solidifying or crystallization of the TPE melt.

In this paper we are considering applications with over molding so we will only discuss over-molding through the hot melt injection molding process, which can easily be applied to co extrusion or other similar plastic processes based on the principle of melt processing.

Wetting:

This is the first important step in adhesion .The thing to consider is the wet ability of TPE on substrate surface. In order to achieve good adhesion the TPE melt and the substrate surface have to come into intimate contact. Obtaining intimate contact of the TPE with the substrate surface really means that interfacial flaws must be minimized or eliminated. Intimate contact occurs when the TPE melt spontaneously spreads over the substrate surface to maximize interfacial contact and minimize contact with other phases. Spreading can be estimated from the critical surface tensions of TPE and substrate, which in turn can be obtained from contact angle measurement. The wetting of TPE melt is not only an interfacial phenomenon, but also depends on the viscosity of TPE melt. Usually lower viscosity TPE melt wets a surface better than a higher viscosity one.

As a rule of thumb, a liquid or melt with lower critical surface tension will spread (and wet) more easily on to a solid surface with higher surface energy. This can be experienced spreading Octane which is having lower surface tension on clean flat glass surface having higher surface energy Spreading silicone oil on to mercury surface will also result in good wetting and intimate contact between the two materials. Figure 19 shows the schematic of epoxy liquid adhesive contacting various polymer surfaces. Epoxy and PET pair gives the best contact because of lower surface tension of the epoxy liquid.

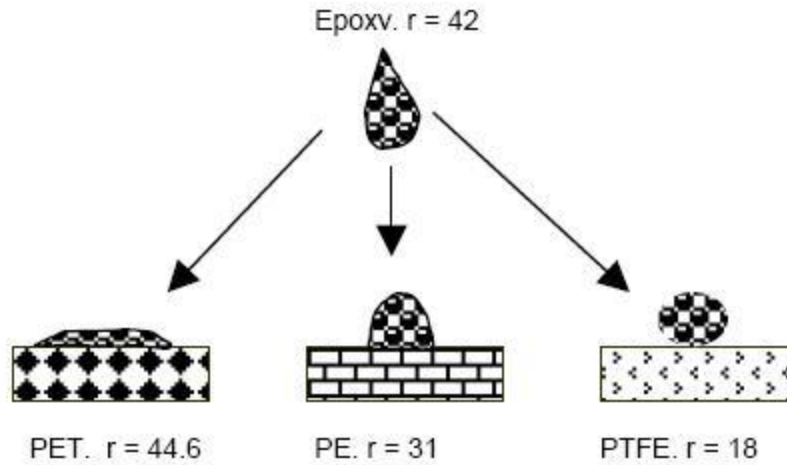

Figure 19

r = critical wetting tension in mJ/m^2 .

As r decreases contact angle of epoxy liquid adhesive increase which results in poor wetting. The surface energies of various solid surfaces are given in Table 1

Solid Surface	Surface Energy (mN/m)
PTFE	18
PE	31
PS	33
PMMA	39
PVC	40
CURED EPOXY	42
PET	44.6
NYLON 6,6	46

Table 1

It is important to note that good wetting does not always mean good adhesion. It only ensures that a good, intimate contact at interface is formed. It requires specific interactions or thermodynamically driven diffusion, or both to create an interphase, between the TPE melt and the solid surface to achieve good adhesion. For example, PE melt may wet Nylon surface easily because of the lower surface tension of PE. But PE will not bond to Nylon since there is no specific interaction between the two materials. This prevents interphase being formed.

Specific Interactions:

Adhesion is usually achieved when the TPE material and the solid substrate have same or similar solubility parameter. The solubility parameter is measure of the ability to form solution, when two materials are mutually soluble and they could form a solution. For example polyolefin TPE like PP/EPDM over-molding onto a PP (polyolefin) substrate. The two materials have similar solubility parameters. When TPE melt comes into contact with PP substrate surface, TPE molecules will diffuse through the interface and into PP bulk. Similarly PP molecules will also diffuse into TPE. An interphase would be formed when the TPE and PP molecules start to entangle refer figure 20. Once the TPE melt is solidified and an interphase with PP / TPE gradient is formed a strong adhesion bond results.

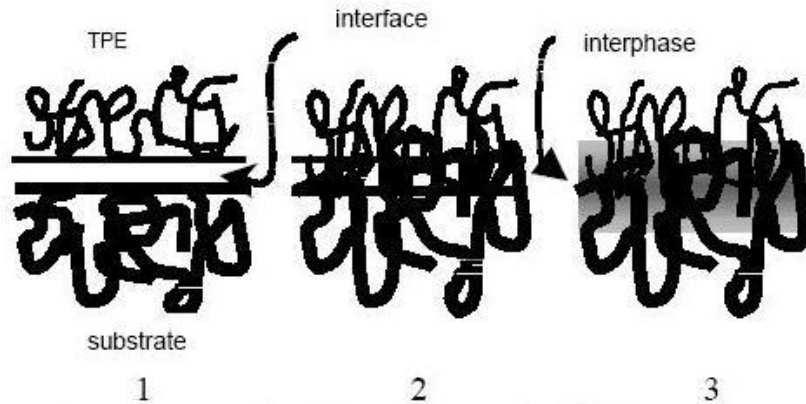

Figure 20.

Figure 20 shows inter-phase formation through diffusion: 1. An interface is formed when TPE melt spreads over substrate surface, 2. Polymer molecules diffuse across the interfacial region and 3. After TPE melt solidifies, an interphase (the shaded area) is formed.

A further example of solubility parameter match is illustrated in the work of Iyengar et al. They carried out a series of simple experiments in which a range of adhesives were used to bond polyethylene terephthalate (PET). The solubility parameters of the adhesives were measured. The solubility parameter of PET is about 10.3. Quality of adhesion in terms of peel strength was

measured versus the solubility parameter of the adhesive see Figure 21. As can be seen, adhesives with substantially different solubility parameters do not create a good bond with PET. When the solubility parameter matches good bond is formed. In most cases the ideal result is cohesive failure.

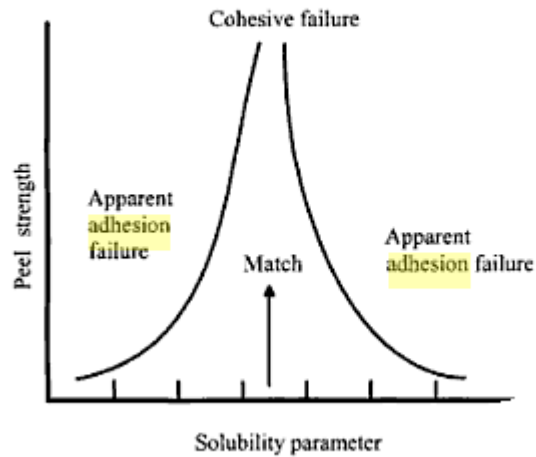

Figure 21

In real life, a good adhesion bond would be achieved if the interfaces could be changed into an interphase through specific interactions such as covalent bond or hydrogen bonding and or if there is a near solubility parameter match.

It is quite difficult to bond a low energy type of TPEs such as polyolefin based or styrenic block copolymer (SEBS, SEPS) based TPEs on to a high energy type of substrates such as Nylon, PET. The TPEs have to be modified to match solubility parameters and or create specific interactions at the interface to create a bonding or to form interphase. Often, adhesion promoter systems, also called coupling agents, have to be added to low energy TPEs. The adhesion promoter systems are mainly responsible for effecting specific interactions. Several types of specific interactions are illustrated below.

Electrostatic Interaction:

Electrostatic forces occur between atoms or molecules which bear a charge. It is shown in figure 22

- ++ Repulsive
- Repulsive
- + - Attractive

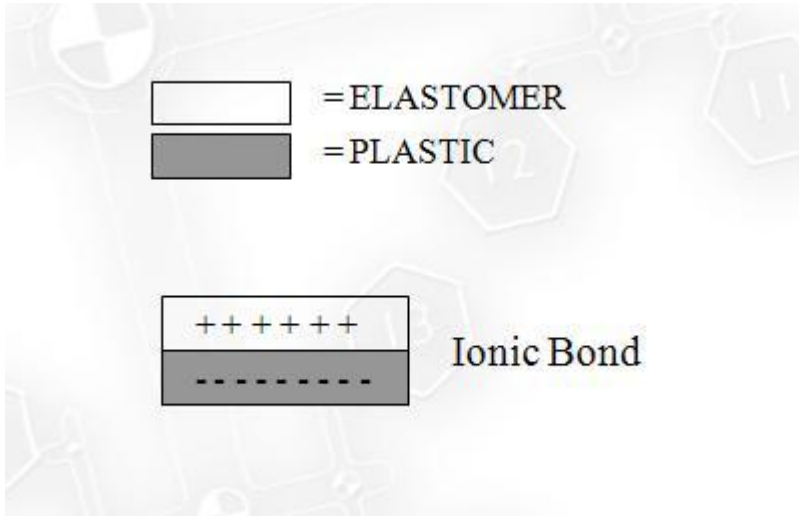

Figure 22

Electrostatic adhesion is used extensively in the coatings industry for example electrostatic powder coating of epoxies on metal surfaces. This type of interaction is rarely seen in TPE over molding.

Van der Waals Force:

Polyolefin TPEs overmolded onto polyolefin is an example of van der Waals interaction. The solubility parameter match makes polymer chain entanglement possible to create strong interphasic bond. Kinetically a molten interface favors bonding.

Dipole-dipole Interaction:

A dipole is formed when a very electronegative atom pairs up with a very electropositive atom in a molecule. The very big electronic difference in the small region creates a virtual charge separation. A molecule such as, 1,1,1- trifluoroethane chemical formula F_3C-CH_3 exemplifies such a dipole.

Hydrogen Bonding:

This is an important type of interaction that could occur in over-molding TPE on to a substrate. Hydrogen bonding formation involves a hydrogen donor such as hydroxyl group –OH and hydrogen bonding acceptor, such as carbonyl group >C=O. Hydrogen bonding is generally weaker than covalent bonding but stronger than van der Waals force.

Covalent Bonding:

This actually involves chemical bond formation. Covalent bonding offers the strongest bonding product. In this situation TPE components or modifiers react with substrate surface to create covalent bonds such as carboxylate group.

The general guidelines to improve adhesion in the overmolding are given as under:

Tips to have better adhesion in Overmolding:

- Match compatibility of TPE and substrate.
- Minimize peeling with sharp transitions in shut-off design.
- Avoid trapping air in cavities via appropriate venting.
- Balance TPE thickness with Shore A hardness for desired “feel.”
- Maintain TPE melt temperature at the level that optimizes adhesion.
- Dry moisture-sensitive materials.
- Select color- carriers that are compatible with both the TPE and substrate.
- Be aware of liabilities of smooth surface textures.
- Keep the TPE flow-length/part- thickness ratio below 150:1.
- Design gating with good adhesion in mind.

It was also observed that these guidelines may vary case to case and substrate- TPE combination. We interacted with couple of molders and they also have different observations on different tools. It was further observed that there were no clear cut understanding and direction on how the bond strength will increase within the given combination of substrate overmold by changing the process parameters, for example one molder experience good adhesion increasing the melt temperature of overmold in one tool where as other found totally opposite results for same combination of substrate and TPE in other tool. They were not able to unanimously come to one conclusion.

12. Adhesion Studies:

Background:

This was the main motivation behind planning and performing adhesion studies. The conclusion drawn from this study would be limited to that combination of overmold and substrate. All popular combinations need to go through this exercise as each combination behaves differently and may respond differently to the process change. Initial studies were planned using polycarbonate polysiloxane copolymer as a substrate material and Polyether based 83 shore A Polyurethane formulation as an overmold material. The polycarbonate copolymer is manufactured by SABIC and TPU is manufactured by Bayer. This is very popular combination in electronics and Hand Held Device manufacturing, which is one of the reasons why this combination was chosen. The other reason for this was a few customer complaints associated with peeling were reported. The peeling was not observed immediately after use but after some years of use. Correlating real time failure with a lab testing itself is challenging and may be a topic for another research project however some propitiatory tests were developed and some numbers with higher factor of safety was used as a correlation to field failure

Specimen Tool:

Now that the combination was fixed the next step was to design a specimen which can be used to determine adhesion. Initially we were thinking of using existing molded product to perform these studies but that would make it complex as we would involve too many variables. To elaborate this one design may have different features, thickness, mold design, process parameters etc than other might respond differently biasing the result of the studies, so it was decided to make dedicated specimen for these studies. This would require a new tool to build. Building a new tool for two shot molding was an expensive affair and need hefty budgets. In order to reduce the dollar amount we decided to use the existing mold base from one of our obsolete tool and build the new specimen tool from the same. We identified a mold base that can fit a molded round of around four inches. Initially we thought of making one big rectangular specimen but that would only tell information about one type of surface finish. We also wanted to study the effect of various textures on adhesion that would have remained unanswered with single specimen or require different inserts for different textures. Making tool with replaceable insert required new mold base and complicated design resulting expensive tool. The objective was set to design a specimen that will fit in existing tool, which will be capable of having a few different textures on substrate and at least one variant of thickness. We also wanted to see the influence of reducing thickness of overmold on the adhesion, so wanted one more specimen with thinner overmold.

The first step for designing the specification of specimen was literature review and some research on the existing ASTM peel test specimen available. Following is the summary of

literature reviewed for various test and test specimen available. ASTM peel test specimens are usually peeled at an angle of 90° or 180°. The most common types of peel tests are:

1. Normalize 180 degree peeling test
2. T peel
3. Floating roller peel

The values resulting from each test method can be substantially different and these tests are more applicable to adhesive and flexible materials like films.

The brief description for these tests is as under

ASTM D 903 Standard Test Method for Peel or Stripping Strength of Adhesive Bonds: This test method details the standard procedures for the determination of the comparative peel or stripping strength characteristics of adhesive bonds when tested on standard-sized specimens and under defined conditions of pretreatment, temperature, and testing machine speed. This method requires the use of a power-driven testing machine with a constant rate-of-jaw separation or of the inclination balance or pendulum type, and conditioning room or desiccators.

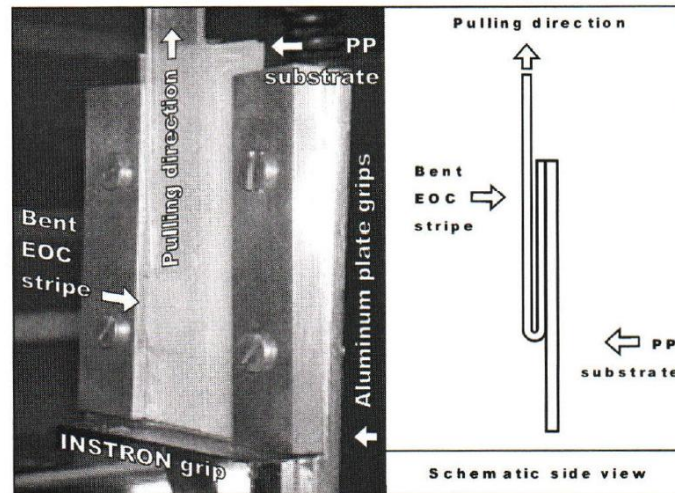

Figure 23

Figure 23 showing the 180 degree peel test.

ASTM D1876 - 08 Standard Test Method for Peel Resistance of Adhesives (T-Peel Test) This test method is primarily intended for determining the relative peel resistance of adhesive bonds between flexible adherents by means of a T-type specimen using a tension testing machine. The bent, unbounded ends of the test specimen shall be clamped in the test grips of the tension testing machine and a load of a constant head speed shall be applied. An autographic recording of the load versus the head movement or load versus distance peeled shall be made. The peel resistance over a specified length of the bond line after the initial peak shall be determined. The procedure is shown in figure 24 below and the specimen is shown in photograph (figure 24) below



Figure 24

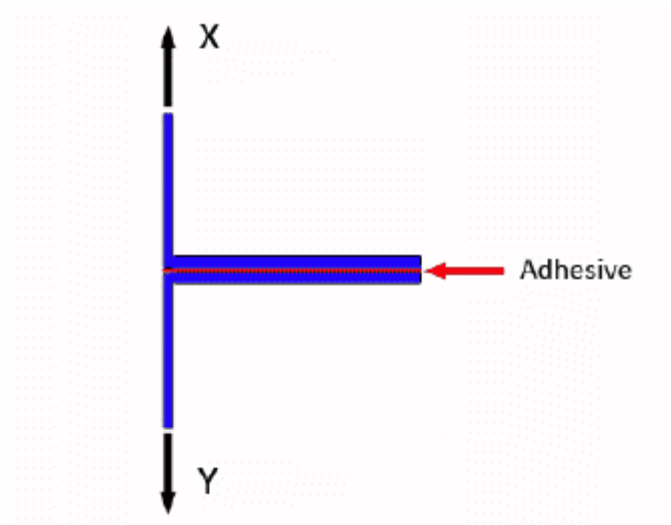

Figure 25

ASTM D3167 - 10 Standard Test Method for Floating Roller Peel Resistance of Adhesives. This test method covers the determination of the relative peel resistance of adhesive bonds between one rigid adherent and one flexible adherent when tested under specified conditions of preparation and testing. Figure 26 describes the floating roller peel resistance.

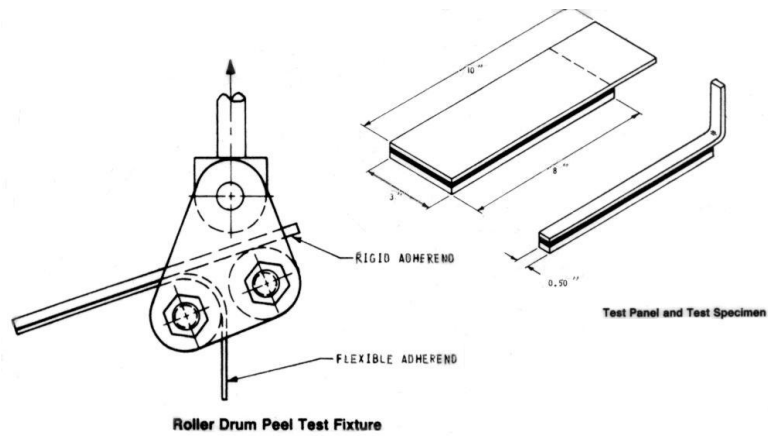

Figure 26

The above tests are mainly design to check adhesive strength or to check the adhesion between the flexible films except the last one. The roller drum uses hard substrate however it is mainly used for metals. Apart from this the TPE manufacturers developed their own procedures to suit hard plastics and TPE overmold. The basic principle observed similar to ASTM peel but more suitable for substrate TPE combination and had a flexibility of pulling thicker flexible (thicker than films) TPE overmold bonded to hard plastic substrate. The other difference is the peel angle, the angle here is 90deg the schematic of test looks like what shown below. Refer figure 27

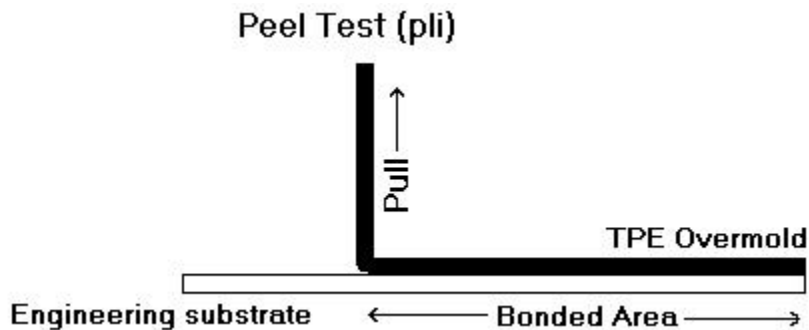

Figure 27

Since our objective was similar to what they do we chosen similar specimen design only difference is the length of specimen, we reduced the length (bonded area) to about 1.5 inches. This was sufficient to get the peel force data we were looking. As we were developing our own test we had a freedom and flexibility to design specimen of our own choice and suitable to our requirement. We designed a disc shown in figure 28 covering six specimens the five with same overmold thickness of 2.5mm and one with 1.5mm thick.

The design of the specimen is shown in the figure below. The individual specimen is cut from the disk as marked by black rectangle.

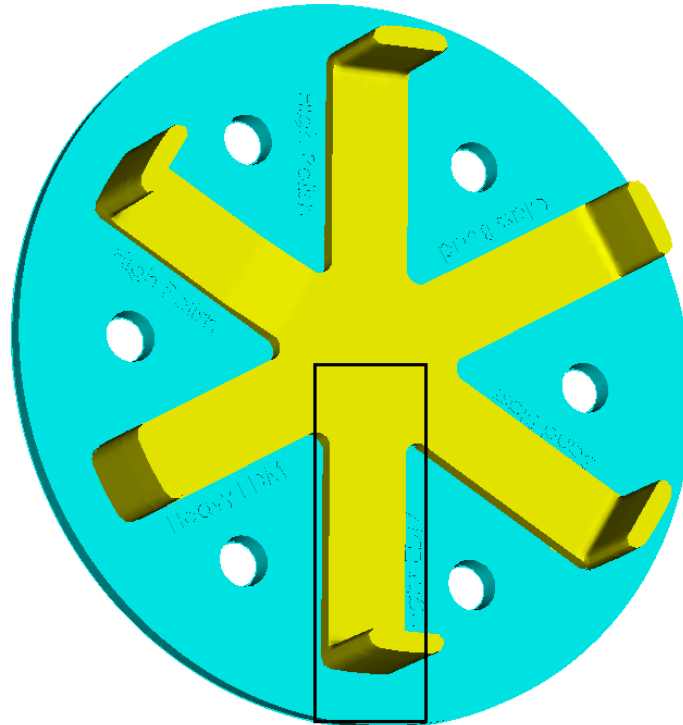

Figure 28

The thickness of 2.5 mm is commonly observed number in injection molded parts and the trend is now to go for thinner wall, as per the resin suppliers recommendations overmold TPE can go as thinner as 1.5 mm thick without compromising the performance. Considering these facts we selected two thicknesses for the specimens. Besides the thickness the other important variable is texture on the substrate, the objective here is to study the effect of substrate's surface roughness on bonding, many industry experts think that adding texture on the surface of substrate helps increasing bond strength, the one explanation in favor of this theory is the surface energy is increased by itching and active surface area increases due to the peaks and valleys created on the surface, the added surface area increases the possibility of wetting and interaction between the two phases adding to the bond strength. There are a few experts who also believes that the adhesion deteriorate with adding aggressive texture and the main reason being air entrapment, the trapped air or gas during the injection stage of second material creates a non functional layer or porosity between the two faces reducing the possibility of wetting and any interactions. The other sources of gases are through the evaporation of low flashpoint additives, oils and volatiles present in the TPE being molded. Again here there is no common understanding on the application of texture; therefore to evaluate the effect of texture on the adhesion, four types of substrate surfaces were prepared mainly high polish, light texture and aggressive texture. The tool designed for the specimen is also capable of producing any combinations for example PP- EPDM, ABS- TPU, ABS-SBC; Nylon-PA based TPEs etc.

Overall the specimen were designed meeting the objective set and providing the evaluation of bond strength for various combination considering, thickness, process variables and texture. The specimen looks good except little shorter bond area than other specimens used in the industry. Prototype test runs were conducted with short specimen; it showed consistent results without observing any issues. The specimen designed was finalized based on above considerations. The other consideration was to selection of two shot molding process, as mentioned earlier there were two options either go for insert overmolding or rotating core sequential molding. We selected two shot insert overmolding for the following reasons;

1. The tool design for this process was simple and the tool was less expensive.
2. As far as bond strength is concerned this process was considered to be the worst case, so it is better to design something for worst case.
3. This process could study one more variable that is substrate handling and substrate temperature and both of these can be studied only using insert molding process.
4. Insert molding option can provide better thermal management for example overmolding of TPE needs mold temperature of 20 to 50 deg C depending on the type of TPE material where as for molding of substrate mold temperature is needed around 70 to 90 deg c depending upon the type of substrate material with rotating tool option it is difficult to maintain this condition but in insert molding, overmold tool is a separate tool so maintaining different temperature can be achieved easily.

The tool was made for two shot insert molding. Trial run was performed to validate specimen dimensions and other details were to the requirement. A few molded specimens were used to determine the test set up and to decide the test procedure. The aim of study was not to have absolute values but to have relative comparison between the peel strength of various substrate overmold combinations.



Figure 29

Figure 29 shows the molded photograph of disc having six specimens. On side of TPE texture configuration is captured.



Figure 30

Figure 30 shows the photograph of individual specimen after cut from the disc

Test set up:

The next step was to develop test set up and testing procedure which will yield consistent, repeatable and accurate results. The Instron machine was used to perform the peel test. This machine is reputed as a universal testing machine and works on the principle of constant rate of pull and the rate of pull can be adjusted depending on the test criteria. In this machine, the test specimen, molded or machined is held in two jaws, one jaw is stationary and the other one is moving at the constant cross head speed. The machine pulls the sample held in the jaws and measures the force required to pull the specimen apart and how much the sample stretched before breaking. The machine records the pull force and the jaws movements. It has ability to produce graph of force Vs elongation which can be plotted very easily. The machine generates the data points which can be easily converted to excel file for further use. The standard machine grips are available to hold tensile test specimens; however our specimen is different from the standard ASTM tensile specimen so we designed the fixture to hold the specimen.

Find below the picture of the test set up. The fixture was created by machining the metal plate which was used as a backing plate to hold machined Delrin plate. The main purpose of this Delrin plate is to provide a smooth surface for sliding specimen when the sample is pulled. As the overmold peeled of the substrate slides smoothly and keep the same direction of pull and the axis in which force applied remains the same. This is the essential parameter and main reason for the sliding action required for the specimen.

The metal back plate is mounted on the machine base with the help of vice. The moving grips hold specimen as shown in the figure 31. The two rollers hold the specimen in place the roller is fixed in the side walls of bracket. The bracket is attached to metal back plate. Figure 31 shows the schematic of test set up and figure 32 shows the actual photograph of test set up.

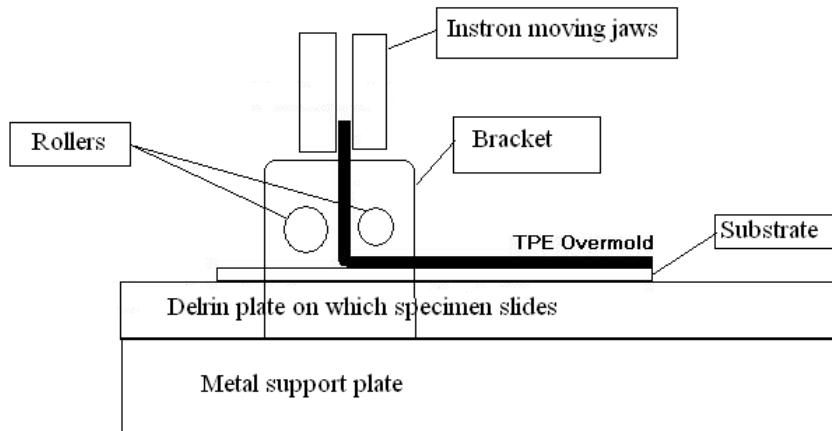

Figure 31



Figure 32

A few test runs were performed to check the set up and with little tweaking the final design was made, shown in the figure above. We also tried out different rate of elongation. The base line used was the rate mentioned in ASTM D638 and also referred the rate used by various industry test labs. It was found that most of them use rate of movement from 10 mm/min to 50 mm/min. We got good synchronization of sliding action of specimen and pulling at the rate of 20 mm per minute. The rate was fixed and around fifteen specimens were checked with this rate to confirm the rate was good to give consistent readings. The typical force versus crosshead displacement graphs has shown in the figure 33 and 34. Figure 33 shows the graph plotted on excel sheet and figure 34 shows the graph being recorded on Instron display.

The force at which peeling continued is called as a **peel force**. This value is related with adhesion and used frequently in the discussions followed. The zone in which peel force is recorded is clearly defined in the paragraph below and this methodology was followed

consistently for all readings. In a few experiment, especially those with lower peel force and sudden peeling it was difficult to figure out stable zone where the peel force remains constant with change in elongation in such cases conscious judgments were used to record peel force, quite a few times such test were repeated.

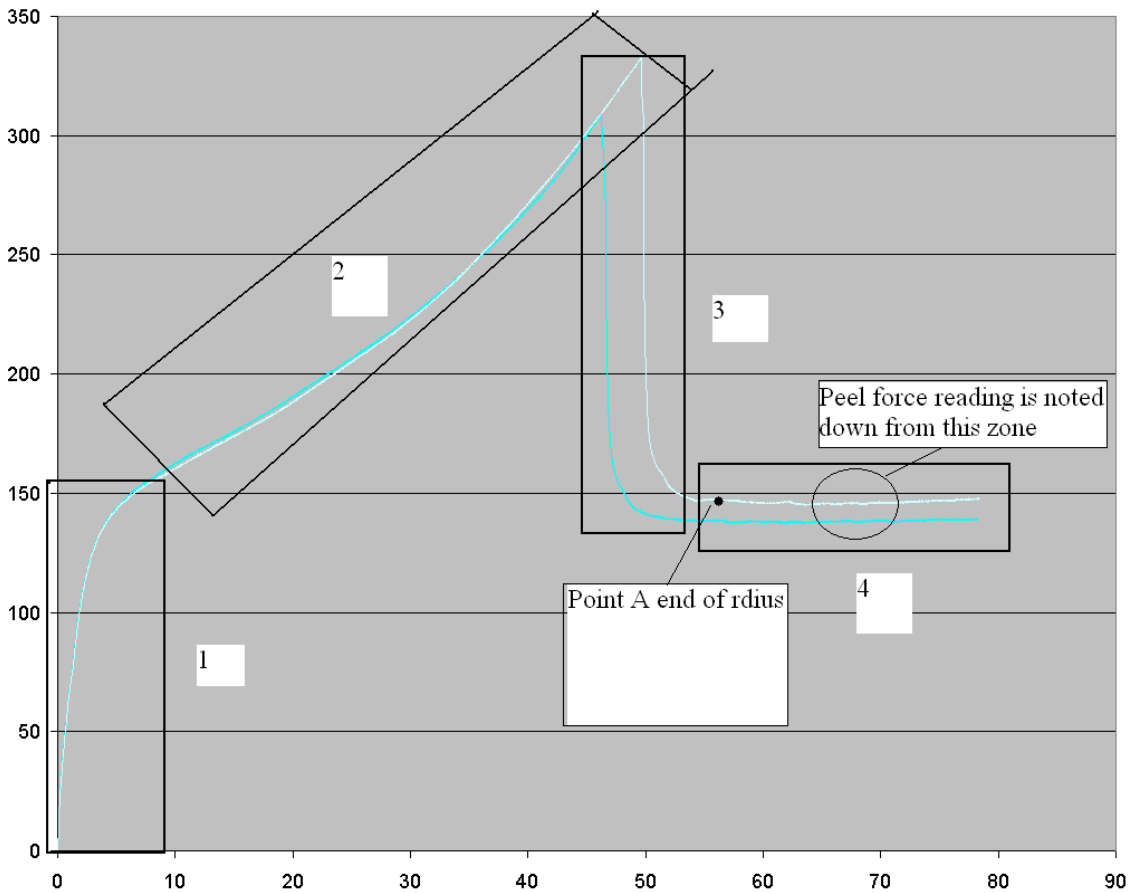

Figure 33

Figure 33 capture the response of specimen under constant force subjected on the specimen by constant speed between the cross head. The X axis shows extension in mm and Y axis shows force required to pull in Newton. The graph can be divided into four zones as marked in figure 33 by numbers.

1. Region 1 -- observed stiff slop, force rises sharply.
2. Region 2-- slope close to 45 deg line, force and elongation may have uniform relation
3. Region 3 -- sudden drop, this is the region where peeling start
4. Region 4 – stable zone with response parallel to X axis

The initial region with stiff slope where rise in force is much higher than the elongation exhibited by the sample. This zone represents the amount of energy required to orient entangled chain in the direction of pull. The considerable energy is lost in orienting the chain in the direction of pull.

Refer the region number two, this is less stiff region immediately followed after stiff region. This reflects the energy spend further stanching the oriented chains the small increase in force results in small increase in elongation. The energy is consumed in stretching covalent bonds on the backbone of polymer chain, the pull force and resulted elongation is almost uniform when the angle goes near to 45 deg.

Refer region 3, this represent sharp fall in force mainly due to the initiation of peeling of TPE, now the force is transferred to the interphase, on microscopic levels some chains from one material might have diffused into other and either physically entangled or some secondary chemical interactions like, hydrogen bonding or Vander Waal forces might be happening at intephases but the force required to dissociate this is smaller as these interaction require much smaller energy to dissociate as compared to covalent bond observed in region two.

This might be the reason for sharp transition from higher force to moderate level.Refer region 4, it is the stable region the response is parallel to X axis and peeling of TPE continued at constant rate and steady state force remains almost constant in some case increase marginally till the TPE layer completely get separated.

The value for peel force is taken from this stable zone, some variation in force seen in the first half of the stable zone so for recording of the peel force the zone is indentified shown by circle which is approximately 10 to 15 mm away from the end of radius,(point A in above figure). The force reading in this circular zone is noted as a peel force.

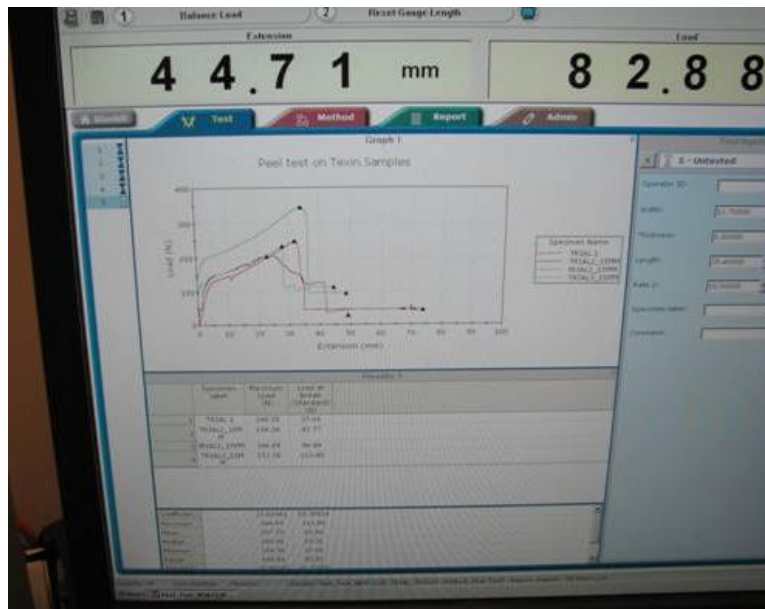

Figure 34

- Three specimens were tested for each experiment, if the variation in the reading is too high then that reading was discarded and another fresh specimen from same experiment was tested.
- The peel force was reported as average of three readings.
- The specimens were marked, first two digit representing experiment number and last digit representing specimen number. For example if we are testing experiment # 3 then specimen will be marked as 31, 32 and 33 for three specimens respectively.
- Periodically the testing was repeated for experiment number with known results for example on day one specimens from experiment 1 to 5 were tested and the peel force were noted down, on day 3 just to validate the set up one more specimen from experiment# 3 was tested and the peel force was confirmed from earlier reading this way the set up was validated.
- Some experiments especially the ones with lower peel force were bit unstable and the spikes in graph observed.

Figure 35 shows the peel test is in progress and figure 36 shows the specimen after test is complete

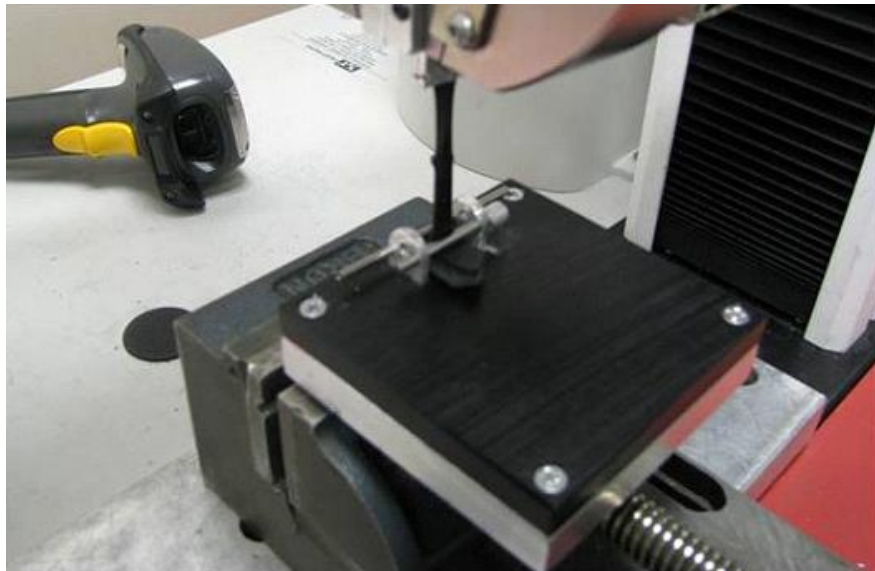

Figure 35



Figure 36

Design of Experiment (DOE) and molding specimens:

As we saw in earlier section the molding process consists of a number of parameters based on time, temperature, pressure, and speed (shear). These parameters have some influence on the adhesion of overmold to the substrate in the given mold for given combination. Apart from this adhesion the other requirement is function performance of substrate, if the adhesion is not good the simpler option is to change the material but changing material in reality just for this reason is not so simple as it looks one has to consider many factors and the product has to undergo requalification with expensive product testing. The other difficulty is to change the mind set of people those who involved directly in development of product and customers who use this product for number of years and have particular spot for the feel of earlier material are hesitant for any change in material. Therefore it is necessary to first optimize the process parameters to get the clear understanding of what best can be achieved by process optimization. The process optimization can be done in more scientific way with the help of DOE or Design of Experiment. A designed experiment is a well-controlled family of tests. Each test is run one or more times. For each controlled test, outputs, also known as responses, are measured. From test to test controlled changes will be made. Once the tests are completed, the data can then be analyzed. Simple graphs can be of great value in furthering your understanding of the results of the experiment. As the data is analyzed, conclusions will be reached as to the best setting for the inputs, or factors. The final step in a designed experiment is to actually try these settings and see if they produce the predicted result based on the analysis. If the results are close to the prediction, and better than any baseline we might have, the experiment will be declared a success.

DOE is nothing but a systematic study of the effects of variables on the quality of the part. Say a study of the effect of melt temperature on the adhesion of overmold is a designed experiment. For example, at 385 deg F of melt temperature, the peel force is 150N and at 420 Deg F of melt temperature the peel force is 100N. So we can infer that the peel force increased by 50 N by reducing the melt temperature by 35 deg F. In DOE terminology, the melt temperature is called a factor, and is set at two levels—a high and a low—and the peel force is called a response. So in this experiment, there is one factor, two levels, and one response. Naturally, as the number of factors and levels increase, the number of experiments will increase. The number experiments can be determined using following formula.

$$\text{Number of experiments} = (\text{number of level})^{\text{number of factors}}$$

In our case as discussed earlier following four factors are most influential as far as adhesion is concerned and we are going to check its effect of it for two levels high and low

1. Melt temperature
2. Shear rate
3. Substrate temperature
4. Mold temperature

The total number of experiment for four factors two levels are $2^4=16$

So we will have to run sixteen experiments in order to establish the relationship between factors and response. The low and high values are set based on the processing recommendations from resin suppliers and the values for the grade of TPU used were shown in table 2.

Table 2

Factors	Units	High level	Low level
Melt temperature	Deg F	485	385
Shear rate	Per seconds	20000	10000
Mold temperature	Deg F	110	70
Substrate temperature	Deg F	200	70

- In the sixteen experiments above four factors were varied and specimens were molded.
- Microprocessor based Injection molding press of 150 ton was used to mold these parts.
- The process parameters were strictly controlled using industry standard guide lines and tolerances.

- The melt temperatures were confirmed taking the air shot on cardboard and measuring the temperature with high accuracy contact pyrometers.
- Measuring mold temperature and substrate temperature were relatively simpler and done with IR pyrometer.
- The mold temperature was measured at four different places to have the understanding of uniformity.
- For a given mold and for a given part shear rate is function of injection time and the shear rate was calculated using following formula for round gate.

$$\text{Shear rate} = 4Q/\pi r^3$$

Where

Q= flow rate in terms of cm³ / second

R= radius of gate in cm

- Materials were pre-dried before molding using recommended parameters, dehumidified dryer were used to dry the material.
- After each process setting a few shots were thrown and once the process was stabilized ten specimens were collected for each experiment run.
- The specimens were checked visually for any molding defects or artifacts before collecting.
- The collected specimens were put in a separate bag with experiment number tag on it. The specimens were conditioned at room temperature for 24 hours before testing.
- The specimens were molded in following sequence. Even the sequence can be a randomized but the problem with this is it takes too much of machine time especially to cool down barrel from higher temperature to lower temperature.

Table 3

Exp No	Mold Temp in deg F	Melt Temp in deg F	Subst Temp in deg F	Shear Rate rec second
1	70	385	70	10000
2	70	385	180	10000
3	70	385	70	20000
4	70	385	200	20000
5	70	465	70	10000
6	70	465	200	10000
7	70	465	70	20000
8	70	465	200	20000
9	110	385	70	10000
10	110	385	200	10000
11	110	385	70	20000
12	110	385	200	20000
13	110	465	70	10000
14	110	465	200	10000
15	110	465	70	20000
16	110	465	200	20000

Table 3 shows DOE planed, experiment wise process parameters used.

13. Results and Discussions:

- Twelve or more specimens from four experiments were tested at a time and is grouped in one.
- The order is purposely randomized
- The experiment number 1, 2, 3,4,5,7, 9,10,11,13 and 15 showed consistency and the deviation between the three readings were very low.
- The experiment numbers 6,8,14 and 16 showed some variation within the reading. Testing repeated couple of times to get best reading.
- The main reason for this variation was the smaller value of peel force and peeling occurred very fast.
- The sudden peeling results in sharp peaks and valleys

Find below table 4 showing the peel force observed for sixteen experiments.

Graphical representation of each reading is captured in graphs below

- Find below the results of experiments in the form of graphs.
- The testing was done in batches.
- Each graph shows 12 or more specimens tested out of four experiments.
- The graph shows plot of force vs. displacement, X axis represent displacement is in mm and on Y axis represents force in Newton is used

Graph 1 below shows the results of experiment number 2,3,10 and 11

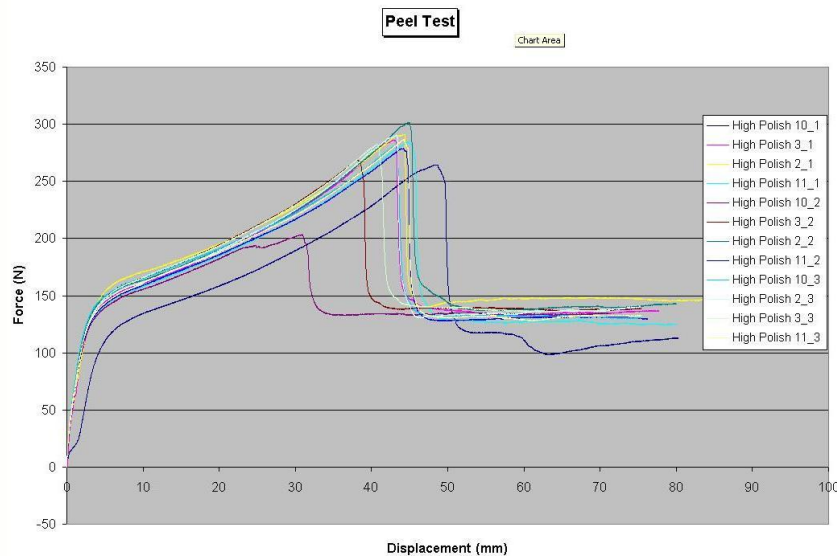

Graphs 2 below shows the results of experiment number 13, 14, 15 and 16

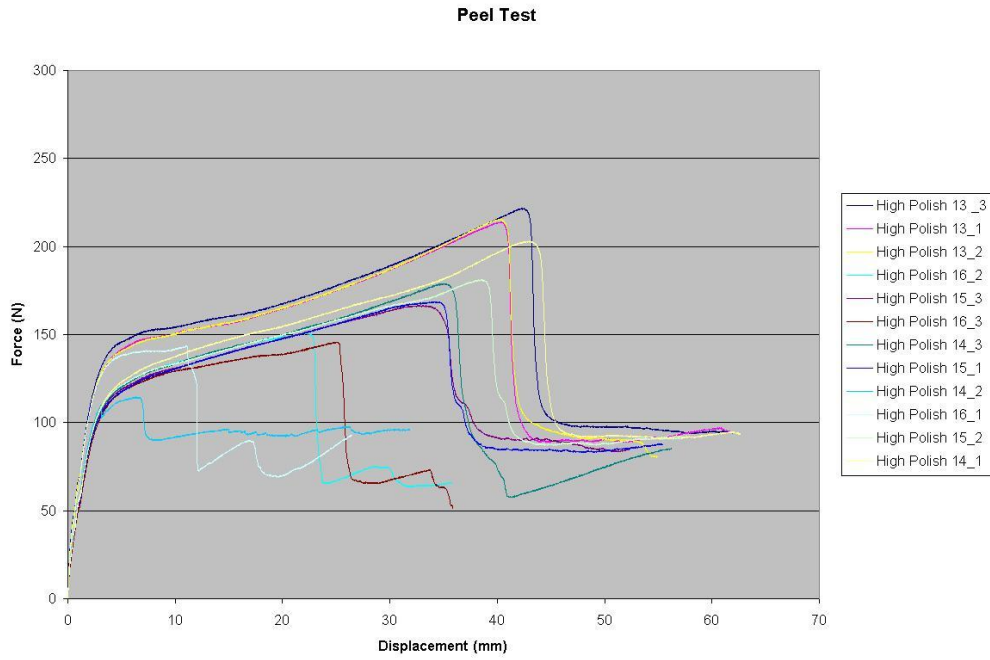

Graphs 3 below shows the results of experiment number 5, 6, 7 and 8

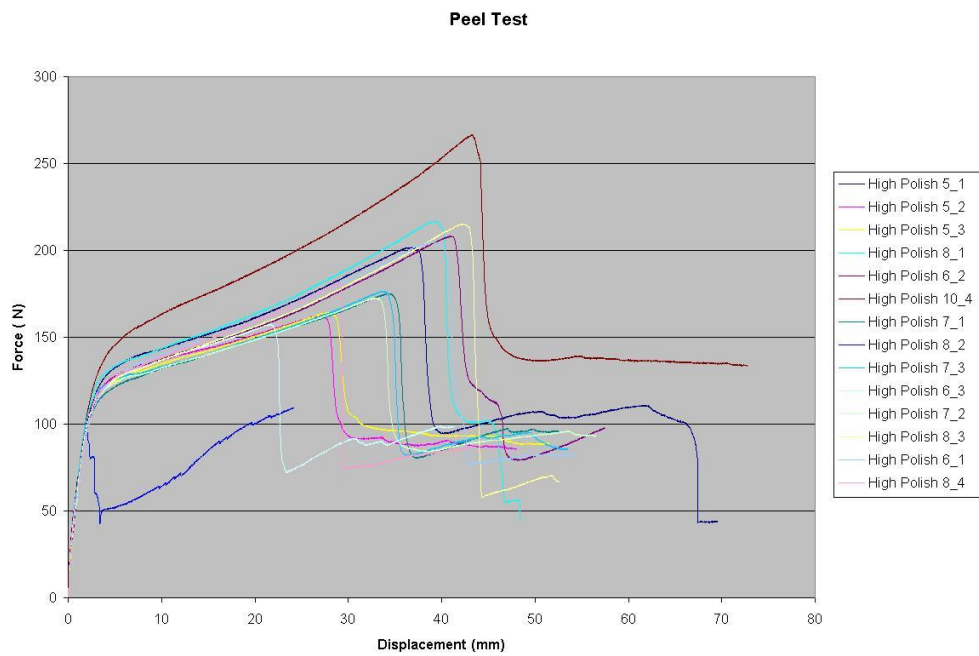

Graphs 4 below shows the results of experiment number 1, 4, 9 and 12

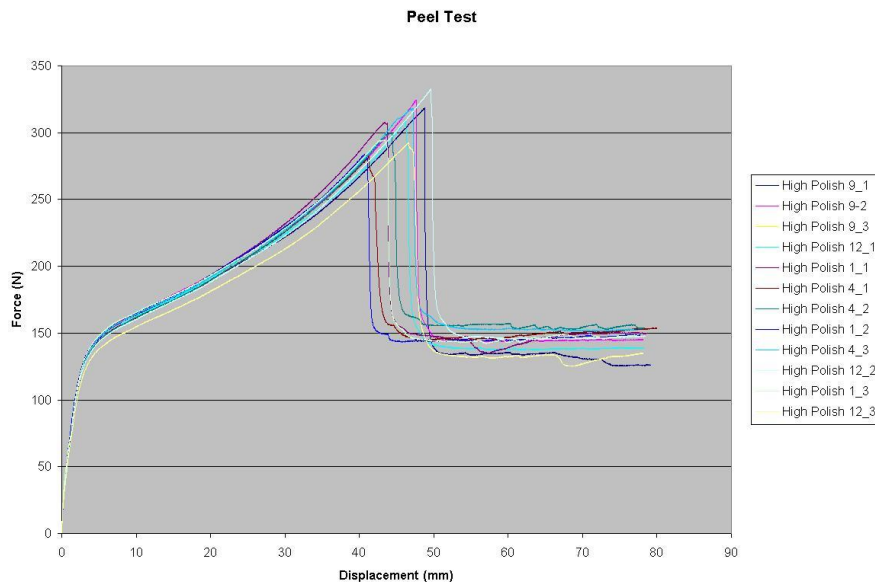

- For the first phase high polished specimens were used for all experiments.
- The summary of the results is shown in the table 4 below the peel force values are given for all experiments.
- Experiment number four showed highest peel force with the value of 151.3 N.
- Experiment number sixteen showed lowest peel force with the value of 68 N.
- Experiment number 2, 3, 9 and 12 are in the same range having the values 136.6, 139.3, 138.6 and 139 N respectively. Group exhibited relatively higher peel force.
- Experiment one showed slightly higher value than above with peel force of 145 N
- Experiment number 5, 7, 8, 14 and 15 are in the same range having the values 95, 88.3, 90.3, 89 and 87.3 N respectively. Group exhibited relatively lower peel force.
- Experiment number six showed second lowest peel force with the value of 82 N.

Table 4 Summary of results

Exp No	Mold Temp in deg F	Melt Temp in deg F	Substrate Temp in deg F	Shear Rate rec second	Peel Force in Newton
1	70	385	70	10000	145
2	70	385	180	10000	136.67
3	70	385	70	20000	139.33
4	70	385	200	20000	151.33
5	70	465	70	10000	95
6	70	465	200	10000	82
7	70	465	70	20000	88.33
8	70	465	200	20000	90.33
9	110	385	70	10000	138.67
10	110	385	200	10000	127.33
11	110	385	70	20000	128.33
12	110	385	200	20000	139
13	110	465	70	10000	93.33
14	110	465	200	10000	89
15	110	465	70	20000	87.33
16	110	465	200	20000	68

Graph 5 shows the graphical representation of summary of results.

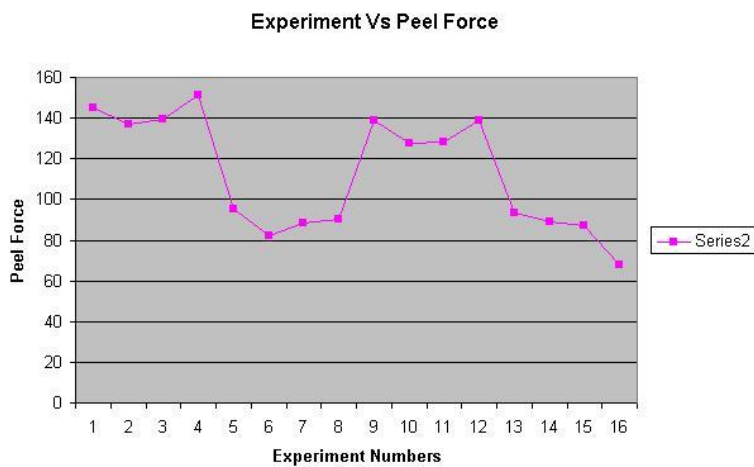

Effect of surface texture:

The other objective of study was to find out the effect of surface roughness on the peel force, for that matter Experiment number 1 was selected for the following reasons:

1. Specimens from Experiment number 1 was used to calibrate the test set up at number of times whenever tests was interrupted so we had longer history with this experiment.
2. It showed consistent values for peel force and followed same trend all the time.
3. Third and far most important this experiment also represent from the group showed higher values for adhesion. It has second highest peel force.
4. The three specimens from each type of texture were tested.
5. The average of three readings was taken as peel force foe that texture.

The table 5 below shows the summary of the peel force required for various textures. All specimens tested were from experiment number one.

Table 5

Surface Texture	Peel Force in Newton	Order of Roughness
High Polish	142.5	Base line
Light EDM	154	1
Heavy EDM	109	4
Sand Blast	142.33	2
Glass Beads	136	3

- The highest roughness, heavy EDM has lowest values of peel force.
- The light roughness has better values of peel force.
- The moderate roughness has in between values of peel force.
- Base line values match with the peel force observed in earlier experiment.
- Light EDM showed excellent results best amongst all readings. The clear winner is light EDM texture, with this peel force values jump from 142N to 154 N.
- It is also observed that light surface roughness help adhesion as a result peel force values increased.
- From the above values it is clear that as the surface roughness increases beyond certain level the force required peeling decreases.

Find below the graphical representation of summary of the results of surface roughness.

Graph 6

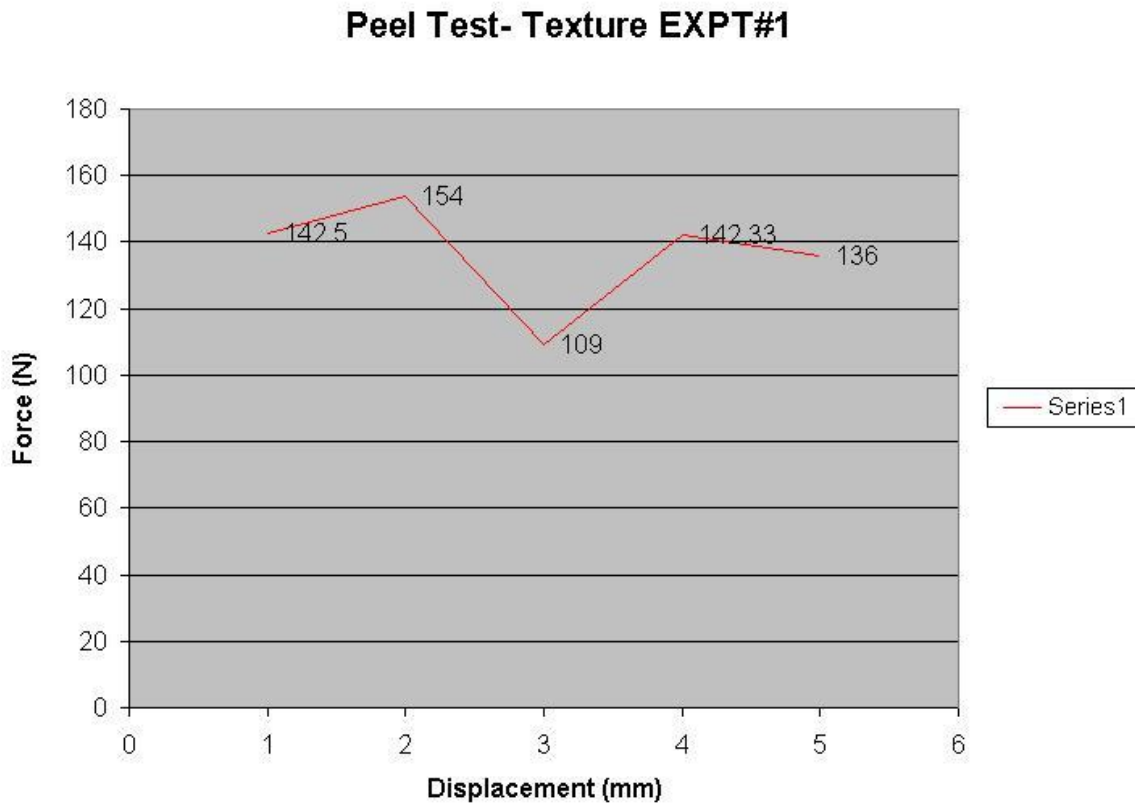

The peeled specimens were observed under microscope and the one thing that noticed was there were no traces of TPU on hard substrate or vice a versa. The bond formed is pure adhesive bond. This is the terminology used by adhesive industry. The following two figures will show the difference in cohesive and adhesive bonding.

In the figure below blue surface represent substrate and yellow surface represent TPE Adhesive Bond - TPE material residue not left behind when TPE is peeled off from the substrate. Figure 37 below represent adhesive bonding.

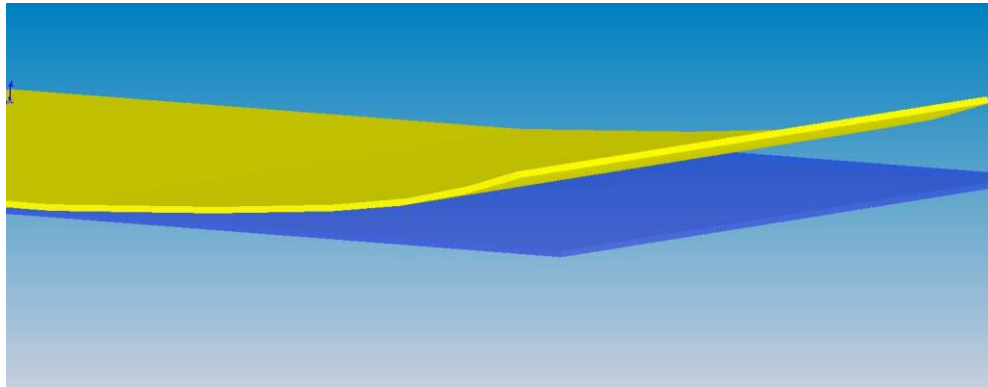

Figure 37

Cohesive Bond – TPE material residue left behind when TPE is peeled off from the substrate. Figure 38 below represent adhesive bonding.

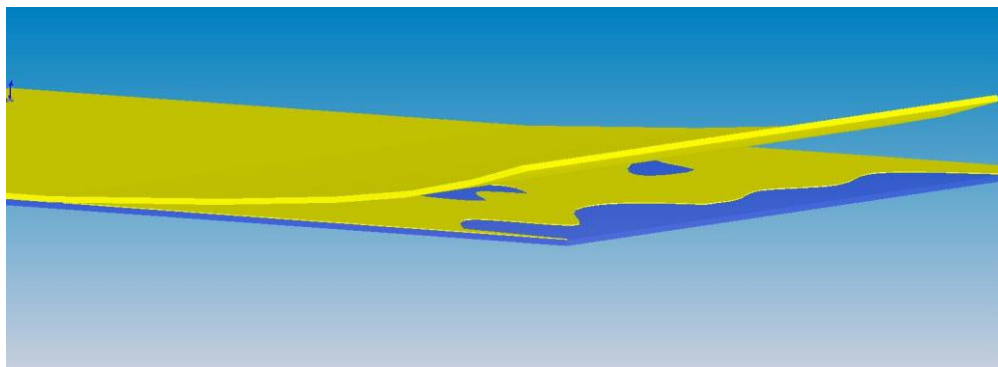

Figure 38

The peeled samples surfaces were also characterized using Scanning Electron Microscopy. Following samples were subjected to Scanning Electron Microscopy

1. Peeled sample from experiment number 1 representing higher peel force
2. Peeled sample from experiment number 16 representing lowest peel force
3. Peeled samples from light EDM from experiment number one
4. Peeled sample from heavy EDM from experiment number one

Following are the observations from SCM images.

On the substrate surface there were lot of inorganic particles observed they were detected using EDS spectra and they were mainly Ti based. This might have came from the coloring

packaged used to color polycarbonate some Si content also detected which is a part of copolymer structure but Ni and Zn particles detected were of surprise, the sources is not clearly understood In addition no residue of TPU was detected on the substrate surface.

There were no much difference in the scan of substrate surface of experiment number 1 and 16.

Find below the various SEM images and EDS spectra. Out of various images shown below figure 43 and 44 are of great importance and they helped revealing the mystery of difference in adhesion. Refer the images captured in figure 43 and 44 showing overmold surfaces. There is vast difference in these two images.

The overmold surface of experiment number 16 is having much higher porosity than the overmold surface of experiment number 1. There were no direct measure of porosity in SEM software but it was approximated using the different software available and found out that the porosity on the surface of experiment number 1 is almost 40 % lower than the porosity on the surface of experiment number 16. This means for experiment 16 there is less active surface area of TPU overmold in contact with substrate. Less area means less possibility of wetting overmold on substrate surface. If active area is less there is lesser interaction between the two phases present. With less interaction there are lower chances of inter diffusion happening resulting in lower adhesion between two phases.

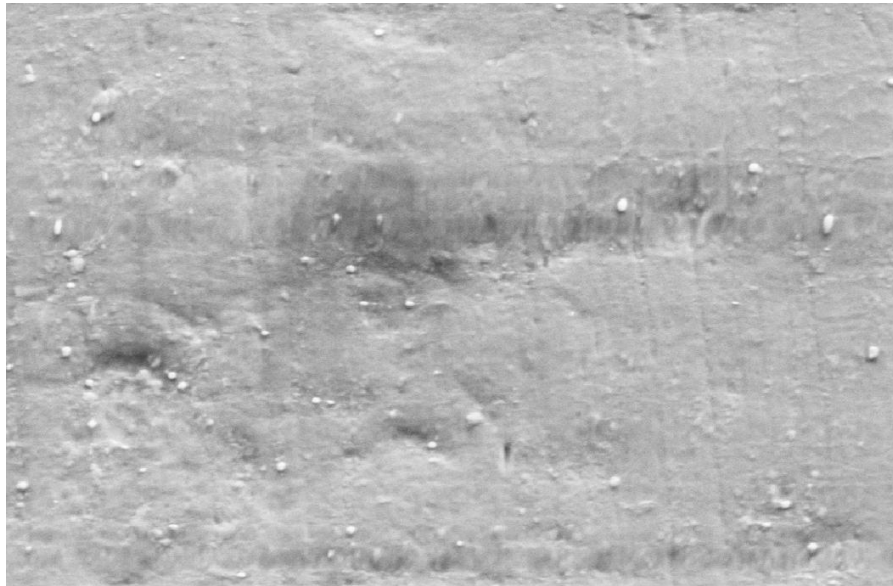

Figure 39 represents the screen grab of the specimen substrate surface from experiment number 1 under SEM with 30K magnification. The white spot is all inorganic impurities and Ti as a main element is detected; find below the EDS spectra taken in the same region.

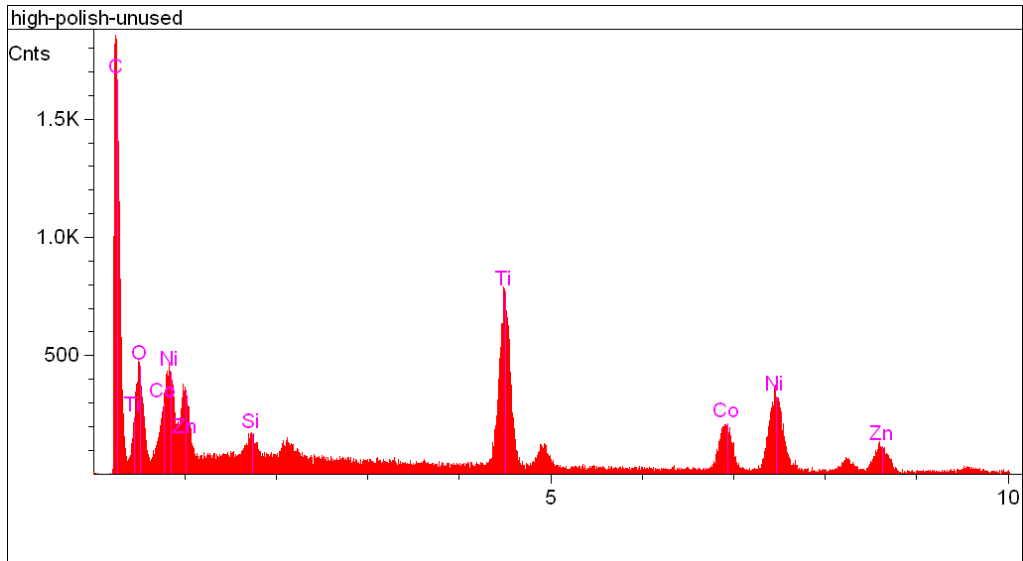

Figure 40

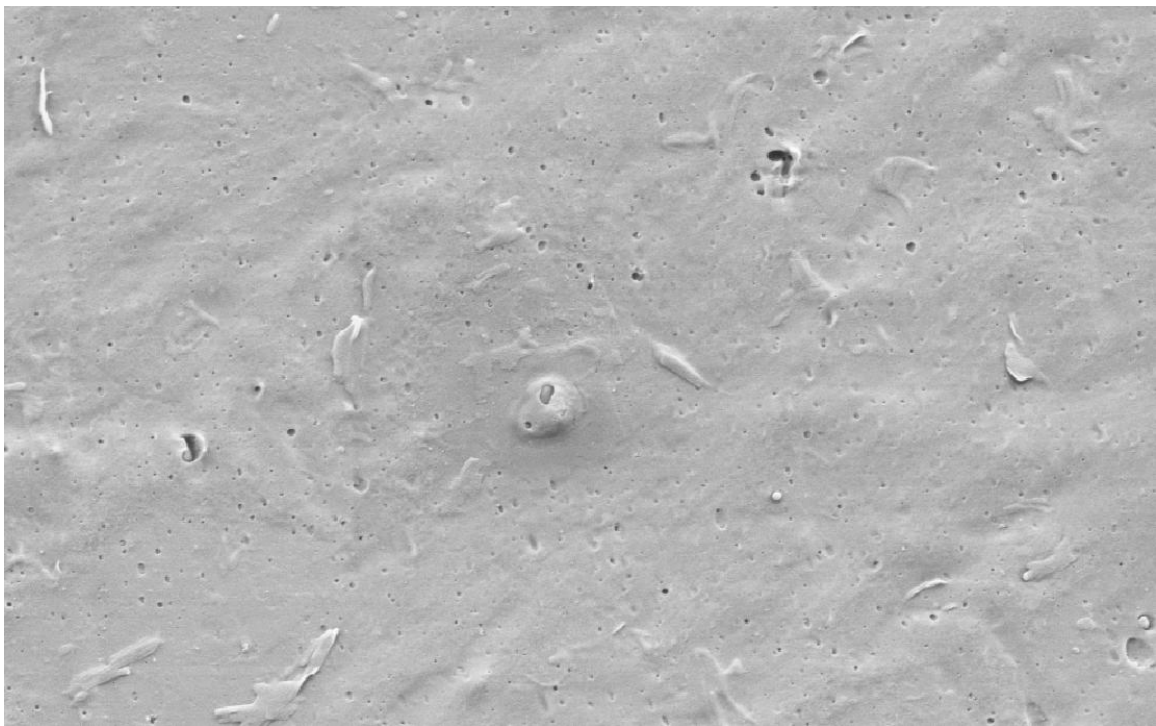

Figure 41 represents the screen grab of the specimen substrate surface from experiment number 16 under SEM with 30K magnification.

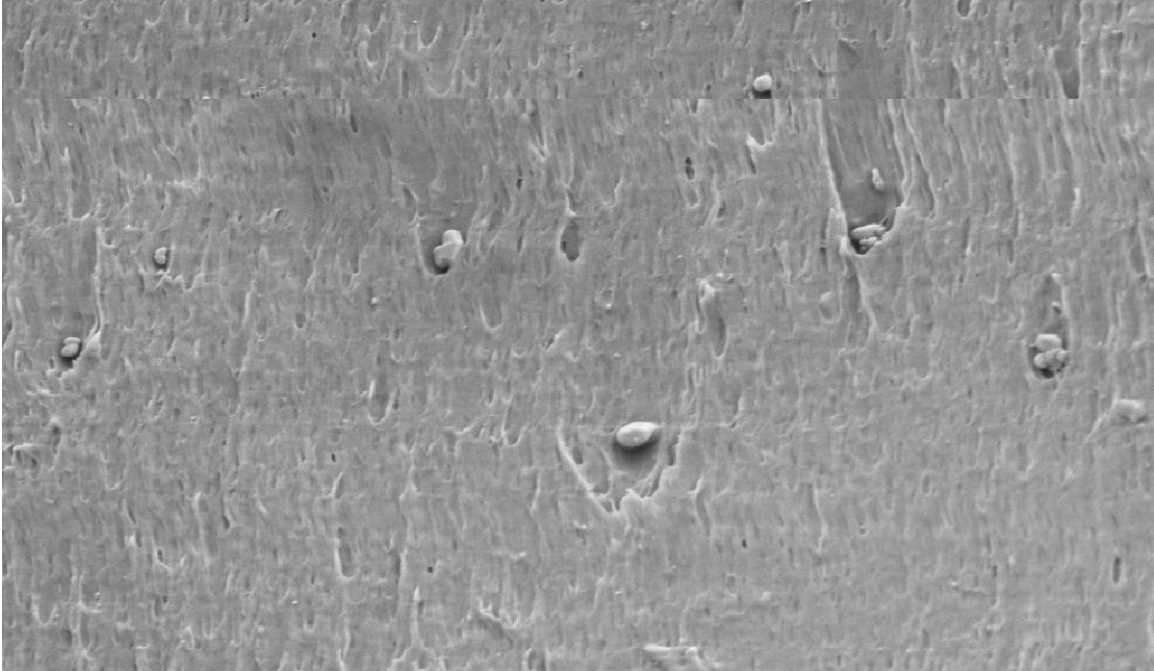

Figure 42 represents the screen grab of the specimen substrate surface from experiment number 1 under SEM with 30K magnification. This is with Heavy EDM texture.

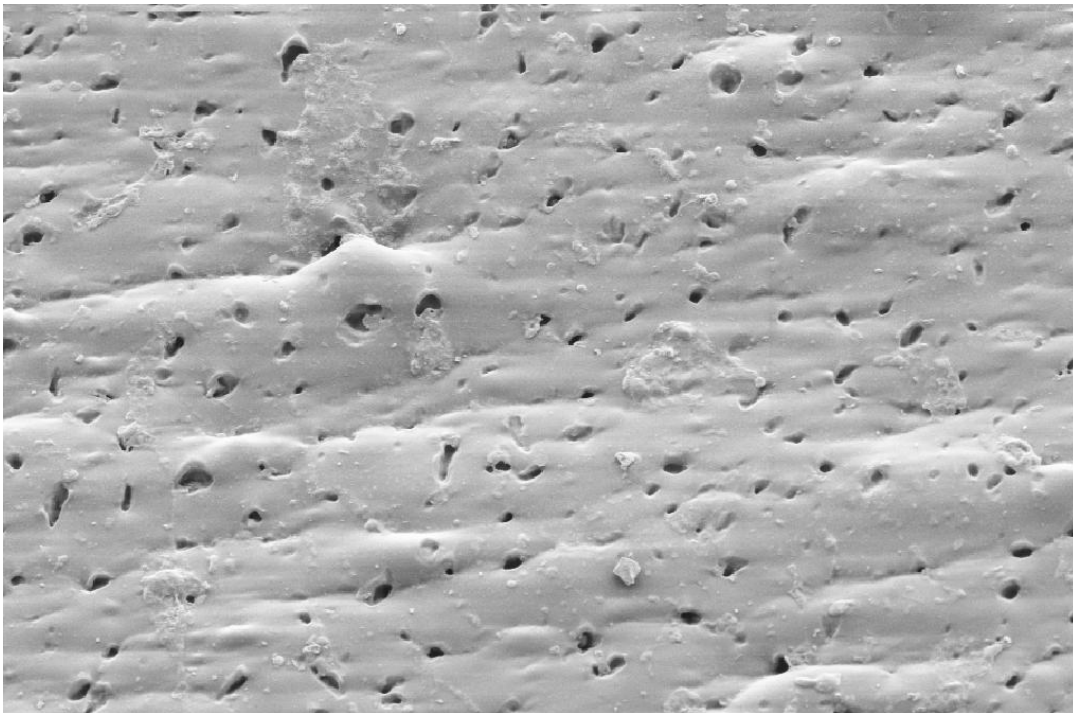

Figure 43 represents the screen grab of the specimen overmold surface from experiment number 1 under SEM with 10K magnification.

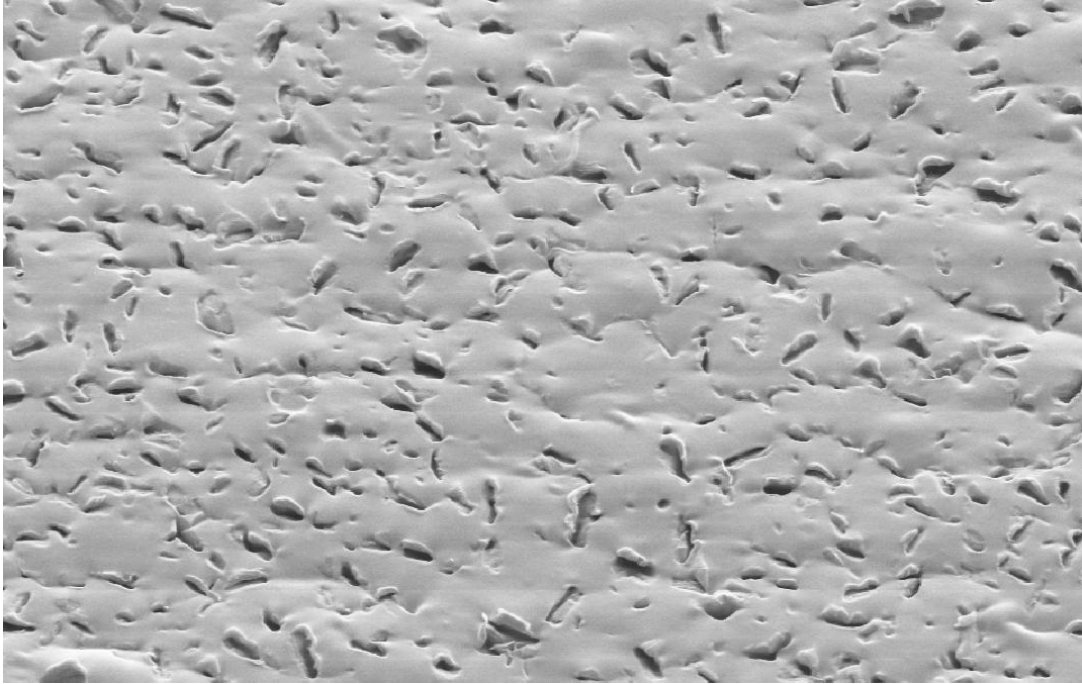

Figure 44 represents the screen grab of the specimen substrate surface from experiment number 16 under SEM with 10K magnification.

14. Conclusion

The one way to conclude the study is plugging in the response values into smart DOE software and it will give us the direct results showing the relationship of factors and response. It will show the effect of four factors considered on adhesion measured in terms of peel force. It will also show the interaction between the various factors and its effect on adhesion. This is interesting software and use of it is universally accepted but here we will interpret the result using human algorithm and logic. The arguments will be done based on the data available to conclude the results

Step 1

Let us group the experiment that performed best and the experiments that performed worst. Find below table 6 showing the experiments that performed the best along with process parameters

Table 6

Exp No	Mold Temp in deg F	Melt Temp in deg F	Substrate Temp in deg F	Shear Rate rec second	Peel Force in Newtons
4	70	385	200	20000	151.33
1	70	385	70	10000	145
3	70	385	70	20000	139.33
12	110	385	200	20000	139
9	110	385	70	10000	138.67
2	70	385	200	10000	136.67
11	110	385	70	20000	128.33
10	110	385	200	10000	127.33

Similarly find below table showing the experiments that performed the worst along with process parameters.

Table 7

Exp No	Mold Temp in deg F	Melt Temp in deg F	Substrate Temp in deg F	Shear Rate rec second	Peel Force in Newtons
16	110	465	200	20000	68
6	70	465	200	10000	82
15	110	465	70	20000	87.33
7	70	465	70	20000	88.33
14	110	465	200	10000	89
8	70	465	200	20000	90.33
13	110	465	70	10000	93.33
5	70	465	70	10000	95

Table 6 shows the top eight experiments in ascending order with the process settings
 Table 7 shows the bottom eight experiments in descending order with the process settings.

Step 2

Now let us consider each factor one by one and try to determine the trend showed based on the summary of results for two sets we have.

Mold temperature

Out of top eight experiments, there are four experiments with lower values of mold temperature and four with higher values of mold temperatures. Out of bottom eight experiments, there are four experiments with lower values of mold temperature and four with higher values of mold temperatures

That means lower and higher mold temperature both level can produce bad or good parts. The number is even split so we can't say which level can produce good or bad parts. We would say that this factor remains neutral. We would also say that the probability of getting good parts with this parameter is 50 %.

Melt temperature

Out of top eight experiments, all of them have lower values of melt temperature. Out of bottom eight experiments, all of them have higher values of melt temperature. No lower melt temperature showed lower values of peel force showing upward trend.

From this we can conclude that lower values of melt temperature yields better adhesion and the success rate is 100 %

Substrate temperature

Out of top eight experiments, there are four experiments with lower values of substrate temperature and four with higher values of substrate temperatures Out of bottom eight experiments, there are four experiments with lower values of substrate temperature and four with higher values of substrate temperatures

That means lower and higher substrate temperature can produce bad or good parts. The number is even split so we can't say which level can produce good or bad parts. We would say that this factor remains neutral. We would also say that the probability of getting good parts with this parameter is 50 %.

Shear rate

Out of top eight experiments, there are four experiments with lower values of shear rate and four with higher values of shear rate. Out of bottom eight experiments, there are four experiments with lower values of shear rate and four with higher values of shear rate

That means lower and higher shear rate can produce bad or good parts. The number is even split so we can't say which level can produce good or bad parts. We would say that this factor remains neutral. We would also say that the probability of getting good parts with this parameter is 50 %.

The melt temperature is the only dominating factor; the other factors have no or minimal effect on the response and they remain neutral as far as adhesion is concerned.

Find below the result from DOE analysis in figure 45 X axis represent melt temperature and Y axis represent peel force.

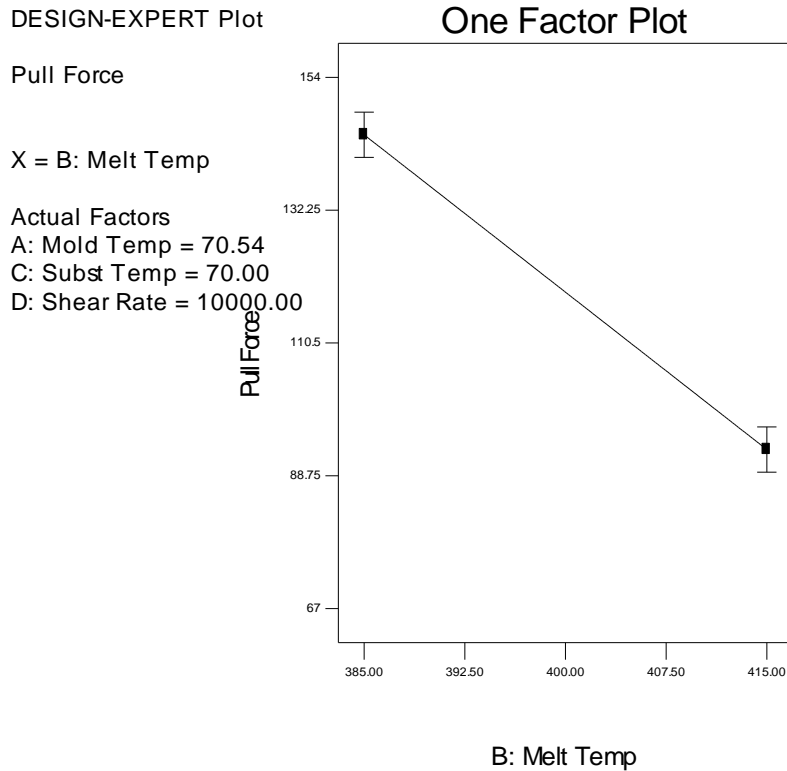

Figure 45

In conclusion we can say that

- **The part produced with lower melt temperature of overmold improves adhesion between hard substrate made out of Polycarbonate Polysiloxane copolymer and the overmold molded out of 83 shore A TPU.**
- **The light EDM treatment on the surface of the substrate helps improving adhesion between overmold and substrate for given combination.**
- **The aggressive texture on the surface of substrate doesn't improve the adhesion between overmold and substrate for given combination.**
- **The other processing parameters like Mold temperature, substrate temperature and shear rate of overmold has no or minimum impact on the adhesion of substrate and overmold for given combination.**

As a fact finding mission, we tried to do the chemical analysis of the failed sample to find out the difference, we decided to take the help of resin supplier, and unfortunately they couldn't

do much. The IR spectra did not give any meaningful information however it is worth to mention what analyst from the resin supplier said. Following is her quote in exact words.

“The bottom line is nothing was noted between the two parts that would chemically explain the bonding difference. However, your notes say that 16 was molded at higher temperatures. This very easily could have caused more wax to migrate in the TPU, leading to poor adhesion. Reducing the amount of wax in the TPU may be the simple answer to improving the adhesion between the two polymers”.

There are several possible theoretical reasons for these observations but we will try to discuss those for which we have the data. The theory put forth here needs to be validated with some analytical means. Authors propose that as a future work.

We have seen from SEM images that there were high amount of porosity observed on the surface of TPU overmold. This is especially seen with the specimen molded with higher melt temperature. Our first hypothesis is the porosity observed on surface is due to trapped air or air entrapment during molding. The argument is if it would have been formed while sample is being pulled some ripping or fractures around the pores would have seen and they were missing in SEM images (refer figure 43 and 44). The surface appears like a foam structure.

We all know that in TPU formulations numbers of oils are used as a plasticizer and for various other functions similarly low molecular weight waxes (refer the quote above from resin supplier analyst), mold release agents, flame retardants and processing aids are used. These additives create gases and vapors when exposed to higher temperature. The amount of gases generated depends on number of reasons but temperature is an important factor so higher the melt temperature higher the gassing and we have experienced this many time in a molding process. The liberated gases take the place of material. The compressible material like TPU easily accommodates them leaving the porosity on the surface.

This porosity might be the main reason for lower peel force observed in experiment 16.

- Higher the porosity lowers the surface area.
- Lower surface area might results lower wetting of TPE on substrate, other than contact angle, area is the main factor for wetting.
- Lower wetting will reduce probability of interaction between the two phases.
- Similarly inter diffusion of molecules are required to form interphase which is a primary indicator of a good bonding.
- As both these polymers have some structural similarity they might have similar solubility parameter.
- Diffusion interaction is important when the solubility parameters are similar.
- Diffusion plays important role in forming good bond and diffusion coefficient is function of area, so reduced surface area will results in lower diffusion.

- Secondly the air entrapment also preventing forming continuous interphase between two materials
- These might be the reasons for experiment number 16 exhibiting lower peel forces.
- Air entrapment explanation can also be applied for surface roughness, from above theory higher roughness should give higher peel force but in reality it is happening opposite.
- It is adventurous to say that surface roughness doesn't help adhesion because we found that light roughness or shallower texture improves adhesion and one reason for this is air entrapment.
- It is easier to escape air from shallower texture than rough texture and in rough texture air entrapment observed is more preventing formation of continuous interphase resulting in lower adhesion.
- This is a known fact was highlighted by so many literature and industry experts.

As a last step of DOE these conditions were tried in actual part using this combination of materials and the part was subjected to real life testing of adhesion to confirm the finding. The parts molded out of higher melt temperature failed at 20,000 cycles where as part molded out of lower melt temperature failed at 40,000 cycles. This test was developed internally and proprietary information of the company and cannot be disclosed without signing of non disclosure but generic principle similar to other test is as under. This simulates the real time failure for adhesion of TPE overmolded on hard plastic substrate.

1. The part is first soaked into the solvent. Usually solvent has some reaction on interphase that is how the solvent is selected.
2. The part where both TPE and hard plastic is exposed is subjected to the vigorous rubbing action.
3. The rubbing action is cyclic and the instrument is cable of counting number of cycle.
4. The part is observed time to time for failure. When the peeling of TPE starts part is said to be failed.
5. The cycle at which part failed or peeling observed is noted down.

15. Path Forward:

Author proposes the same study to be carried out evaluating different combinations and if possible generalize the observations for each parameter unless some different trend observed in any combination.

The other thing is to find out some analytical methods which will be useful revealing the surface chemistry possibly focus on what had happened during molding. This will also help generating data in supporting the conclusion and theory discussed in this paper.

Reference

1. A.J. Kinloch, C. C. Lau, and J. G. Williams *Int. J. Fracture*, 66, (1994), pages 45-70.
2. I. Georgiou, H. Hadavinia, A. Ivankovic, A.J. Kinloch, V. Tropsa, J.G. Williams, *The Journal of Adhesion*, 79, 1-27 (2003).
3. J.G. Williams, H Hadavina, B Cotterell, *Int Journal of Solids and Structures*,42 (2005), 4927-4946.
4. L.F. Kawashita, D. R. Moore, J. G. Williams *J. Mat. Sci.* 40, (2005) 1-8.
5. L.F. Kawashita *The Peeling of Adhesive Joints* PhD thesis University of London 2006
6. Ehritt, J. Avoid Pitfalls in Multi-Material Molding. *Plastics Technology*
7. Hansen, M. Gas-Assist Injection Molding: An Innovative Medical Technology. *Medical Device & Diagnostic Industry* 26, no. 8, 2005: 84–93.
8. Hudacek, L. How to Optimize Adhesion in Hard-Soft Overmolding *Plastics Technology*
9. Stewart, R. New Polymers Offer Advantages for Medical Devices and Packaging. *Plastics Engineering* 1, no. 10, 2005:21–27
10. Dr Matteo Terragni 2K technologies for PP GF applications
11. Marco Dondero, Jose´ M. Pastor,^{2,3} Jose´ M. Carella,¹ Claudio J. Perez Adhesion Control for Injection Overmolding of Polypropylene With Elastomeric Ethylene Copolymers
12. D.Y. Huang and R.S. Chen, *Polym. Eng. Sci.*, 39, 2155 (1999).
13. D. Weng, J. Andries, P. Morin, K. Saunders, and J. Politis, *Injection Molding Technol.*, 4, 22 (2000).
14. A.R. Carella, C. Alonso, J.C. Merino, and J.M. Pastor, *Polym. Eng. Sci.*, 42, 2172 (2002).
15. M.V. Candal, A. Gordillo, G. Terife, and O.O. Santana, Effect of the Process Conditions Over the Adhesion Between Two Overmolded Polymers, in 65th Annual Technical Conference

and Exhibition (Society of Plastic Engineers, ANTEC 2007), Society of Plastic Engineers, Brookfield, CT , 619 (2007).

16. L.M. Arzondo, N. Pino, J.M. Carella, J.M. Pastor, J.C. Merino, J. Poveda, and C. Alonso, *Polym. Eng. Sci.*, 44, 2110 (2004). 6. R. Alamo, R. Domszy, and L. Mandelkern, *J. Phys. Chem.*, 88, 6587 (1984).

17. R. Alamo and L. Mandelkern, *Macromolecules*, 22, 1273 (1989).

18. L. Godail and D.E. Packham, *J. Adhes. Sci. Technol.*, 15, 1285 (2001).

19. W.H. Wanger *Cooling of Polymer Filaments during Melt-Spinning*, PhD Dissertation, University of Denver (1989).

20. J.R. Isasi, R.G. Alamo, and L. Mandelkern, *J. Polym. Sci. Part B: Polym. Phys.*, 35, 2945 (1997).

21. P. Dias, Y.J. Lin, B. Poon, H.Y. Chen, A. Hiltner, and E. Baer, *Polymer*, 49, 2937 (2008).

22. D. Garcia-Lopez, J.C. Merino, I. Gobernado-Mitre, and J.M. Pastor, *J. Appl. Polym. Sci.*, 96, 2377 (2005).

23. W.W. Graessley, R. Krishnamoorti, N.P. Balsara, R.J. Butera, L.J. Fetters, D.J. Lohse, D.N. Schulz, and J.A. Sissano, *Macromolecules*, 27, 3896 (1994).

24. N.P. Balsara, L.J. Fetters, N. Hadjichristidis, D.J. Lohse, C.C. Han, W.W. Graessley, and R. Krishnamoorti, *Macromolecules*, 25, 6137 (1992).

25. J.K. Maranas, M. Mondillo, G.S. Grest, S.K. Kumar, P.G. Debenedetti, and W.W. Graessley, *Macromolecules*, 31, 6991 (1998). DOI

26. Alphonsus V. Pocius, *Adhesion and Adhesives Technology*, Hanser Publishers, 1997

27. Arthur W. Adamson, *A Textbook of Physical Chemistry*, Academic Press, 1973

28. Edinand Rodriguez, *Principles of Polymer Systems*, 3rd Ed., Hemisphere Publishing Corporation, 1989

29. Souheng Wu, *Polymer Interfaces and Adhesion*, Marcel Dekker, 1982

30. W.D. Harkins, F.E. Brown, *J. Am. Chem. Soc.*, 41 (1919), 499

31. Y. Iyengar, D. Erickson, *J. Appl. Polym. Sci.*, 11 (1967), 2311

32. S. Wu, J. Macro mol. Sci., C10, 1(1974)
33. T.S. Kuhn, The Structure of Scientific Revolutions, University of Chicago Press, Chicago,1970.
34. A.V. Tobolsky, Rubber Word 138, 857 .
- 35.A.A.Montagna, A.H. Dekmezian, R.M. Burkhart,CHEMTECH, December 1997, pages 26-31
36. J.A. Ewen, Scientific American, May 1997, pages 86-91.
37. G. Holder, N.R. Legge, Thermoplastic Elastomer
38. Charles A. Harper, Handbook of Plastics, Elastomers and Composites, 2ndedition, 1992,
- 39.N. Tshihara, Macromol. Symp., 89, 553-562 (1995).
- 40.By Alphonsus V. Pocius Adhesion and adhesives technology: an introduction
- 41.*Dexi Weng, John Andries, Phil Morin, Keith Saunders, John Politis* TPE Overmolding Compounds for the Next Millenium

Table number 1- Source Teknor Apex

Figures taken from the following sources

Figure Number	Sources
1	tutornext.com
2	pslc.ws
3	pslc.ws
4	pslc.ws
5	pslc.ws
6	pslc.ws
7	pslc.ws
8	pslc.ws

9	pslc.ws
10	chemsystems.com
11	chemsystems.com
12	chemsystems.com
13	multishot.com
14	multishot.com
15	multishot.com
16	multishot.com
17	GLS
18	Adhesion and adhesives technology
19,20	Teknor apex
21	Y. Iyengar, D Erickson, J. Appl. Polyer Sci
22,37,38	GLS
23	interscience wiley.com
24,25	advance polymer alloys
26	Wyoming test fixture