

# **Stony Brook University**



OFFICIAL COPY

**The official electronic file of this thesis or dissertation is maintained by the University Libraries on behalf of The Graduate School at Stony Brook University.**

**© All Rights Reserved by Author.**

**A dynamic oyster reef bioenergetics model: predictions of secondary  
production based on different restoration scenarios**

A Thesis Presented

by

**Elizabeth Maria Gomez**

to

The Graduate School

in Partial Fulfillment of the

Requirements

for the Degree of

**Master of Science**

in

**Marine and Atmospheric Science**

Stony Brook University

**August 2015**

**Stony Brook University**

The Graduate School

**Elizabeth Maria Gomez**

We, the thesis committee for the above candidate for the  
Master of Science degree, hereby recommend  
acceptance of this thesis.

**Bradley J. Peterson**  
**Associate Professor**  
**School of Marine and Atmospheric Sciences**

**Janet A. Nye**  
**Assistant Professor**  
**School of Marine and Atmospheric Sciences**

**Stuart R. Borrett**  
**Associate Professor**  
**University of North Carolina Wilmington**  
**Department of Biology and Marine Biology**

This thesis is accepted by the Graduate School

Charles Taber  
Dean of the Graduate School

Abstract of the Thesis

**A dynamic oyster reef bioenergetics model: predictions of secondary  
production based on different restoration scenarios**

by

**Elizabeth Maria Gomez**

**Master of Science**

in

**Marine and Atmospheric Science**

Stony Brook University

**2015**

The presence of oyster reefs augments the biomass and abundance of many transient fish and crustacean species. Therefore, restoration of oyster reefs has become an increasingly common practice in coastal areas with the goal of enhancing production of transient fish. However, predicting the effect of oyster restoration on transient fish community biomass remains elusive. To address this challenge, I created a trophic bioenergetic model to understand how energy transfers in an oyster reef and assess the effects of various restoration strategies on transient fish species. The model used a set of functional groups representing organisms commonly found in an oyster reef and a set of ordinary differential equations describing the growth of these functional groups. The constructed model was evaluated using empirical data from a restoration project in the northern Gulf of Mexico. Three different scenarios were used to simulate restoration

strategies relating to (1) oyster growth rate, (2) oyster carrying capacity, and (3) dependence of transient fish on oyster reef derived prey. Model simulations revealed that enhancing the oyster growth rate both reduced the amount of time for the oyster reef community to stabilize and produced biomass increases for the transient fish community. Additionally, the biomass of transient fish was higher when consumption from an outside source, representing an adjacent habitat, was maintained than when the majority of the transient fish consumption was derived from the oyster reef. These findings highlight the need for restoration strategies that focus on favorable conditions for oyster growth and maintain connectivity among estuarine habitats. As the number of projects and monetary effort for oyster restoration continues to increase, models could be used as tools to understand the possible effects of restoration projects on transient fish communities and set goals for restoration projects.

## **Dedication Page**

These past two years would not have been possible had it not been for the support of all of my family and friends. My parents, Emilda and Luis, and my siblings, Emilda and Ernesto, you have always been there to cheer me on and support me every step of my life and career. Phil McCoy, nothing would have been the same had it not been for you, Thank You. All of the new friends that I made at Stony Brook have made these past two years a wonderful experience, especially my friends at the Peterson Lab. All of you were like a family and made coming to work fun.

## Table of Contents

<b>List of Figures</b> .....	<b>vii</b>
<b>List of Tables</b> .....	<b>ix</b>
<b>Acknowledgments</b> .....	<b>x</b>
<b>Introduction</b> .....	<b>1</b>
<b>Methods</b> .....	<b>8</b>
Functional Groups .....	8
Bioenergetic Model .....	9
Data Acquisition .....	14
Parameter Selection .....	15
Model Evaluation .....	16
Model Scenarios .....	18
<b>Results</b> .....	<b>22</b>
Model Evaluation .....	22
Scenario Analysis .....	25
<b>Discussion</b> .....	<b>31</b>
Model Scenarios .....	32
Conclusions .....	38
<b>Literature Cited</b> .....	<b>40</b>
<b>Figures</b> .....	<b>47</b>
<b>Tables</b> .....	<b>57</b>
<b>Appendix I</b> .....	<b>64</b>
<b>Appendix II</b> .....	<b>66</b>

## List of Figures

- Figure 1.** Model diagram describing the flow of carbon among functional groups in the oyster reef bioenergetics model. Boxes represent functional groups and arrows represent direct consumption, among functional groups. Dashed line between Oysters and On-reef Invertebrates proportional interaction between this two groups used to describe On-reef Invertebrates growth ..... 47
- Figure 2.** Continuous temperatures from USGS Station LDWF/USGS 07381349 at Sister Lake, LA, with overlaying sine function used as temperature forcing function in bioenergetics model ..... 48
- Figure 3.** Diet percentage distribution for Transient Non-Piscivorous Fish and Transient Piscivorous fish used for the baseline model and *Simulation 3: Changes to Dependence on Oyster Reef Derived Prey*. Percentage parameters for baseline diet distribution can be found on Table 3. .... 49
- Figure 4.** Monthly model predicted biomass for functional groups. Grey dots represent monthly averaged biomass purple triangles represent monthly biomass of functional groups obtained from the Louisiana restoration project. **a.** Oysters. **b.** Reef resident fish, such as blenny and gobies. **c.** Transient non-piscivorous fish, such as croaker, black drum, and stingray. **d.** Transient piscivorous fish such as perch, snapper, and seatrout. Bars represent standard error for monthly averages..... 50
- Figure 5.** Monthly averaged model predicted biomass vs field-observed monthly averaged biomass for MSE analysis. **a.** Transient non-piscivorous fish. **b.** Transient piscivorous fish. Dashed red line is 1:1 line representing the line along which perfect model predictions would lie on compared to empirical data ..... 51
- Figure 6.** Monthly-averaged model predictions from Scenario 1 produced by increases to the oyster carrying capacity **a.** Oysters. **b.** Reef resident fish, such as blenny and gobies. **c.** Transient non-piscivorous fish, such as croaker, black drum, and stingray. **d.** Transient piscivorous fish such as perch, snapper, and seatrout. Bars represent standard error for monthly averages ..... 52
- Figure 7.** Monthly-averaged model predictions from Scenario 1 produced by a decrease to the oyster carrying capacity **a.** Oysters. **b.** Reef resident fish, such as blenny and gobies. **c.** Transient non-piscivorous fish, such as croaker, black drum, and stingray. **d.** Transient piscivorous fish such as perch, snapper, and seatrout. Bars represent standard error for monthly averages ..... 53
- Figure 8.** Monthly-averaged model predictions from Scenario 2 produced by increases to the oyster growth rate **a.** Oysters. **b.** Reef resident fish, such as blenny and gobies. **c.**



Transient non-piscivorous fish, such as croaker, black drum, and stingray. **d.** Transient piscivorous fish such as perch, snapper, and seatrout. Bars represent standard error for monthly averages ..... 54

**Figure 9.** Monthly-averaged model predictions from Scenario 2 produced by a decrease to the oyster growth rate **a.** Oysters. **b.** Reef resident fish, such as blenny and gobies. **c.** Transient non-piscivorous fish, such as croaker, black drum, and stingray. **d.** Transient piscivorous fish such as perch, snapper, and seatrout. Bars represent standard error for monthly averages ..... 55

**Figure 10.** Monthly-averaged model predictions from Scenario 3 produced increasing the dependence of transient fish on oyster-reef derived prey **a.** Oysters. **b.** Reef resident fish, such as blenny and gobies. **c.** Transient non-piscivorous fish, such as croaker, black drum, and stingray. **d.** Transient piscivorous fish such as perch, snapper, and seatrout. Bars represent standard error for monthly averages ..... 56

## List of Tables

<b>Table 1.</b> Fish species collected from restoration study, and assignment to appropriate functional group.....	57
<b>Table 2.</b> Functional group model parameters .....	58
<b>Table 3.</b> Diet distribution input for model. ....	59
<b>Table 4.</b> Ranked list of parameters for SI and RD Index sensitivities on biomass at day 1281 of transient non-piscivorous fish .....	60
<b>Table 5.</b> Ranked list of parameters for SI and RD Index sensitivities on biomass at day 1281 of transient piscivorous fish .....	62

## **Acknowledgments**

I would like to thank all of the members from the Peterson Marine Community Ecology Laboratory for their support: Dr. Amber Stubler, Dr. Brad Furman, Rebecca Kulp, Diana Chin, Lisa Jackson, Amanda Tinoco, and Stephen Heck. I would also like to thank Dr. John Carroll for his help. I need to give a special thanks to my two readers, Dr. Stuart Borrett from the University of North Carolina Wilmington and Dr. Janet Nye of Stony Brook University for all of their support, answering my questions, and spending the time to teach me about modeling and R. This work was possible thanks to their patience and guidance, which allowed me to understand and correct my mistakes as I went along. Finally, none of this would have been possible without the support of my advisor Dr. Bradley Peterson, who gave me the freedom to follow my desire and was invaluable in helping me figure out my research question over these past years, I have grown both academically and personally thanks to your guidance and advice.

## Introduction

Coastal habitats—mangroves, rocky intertidal, salt marshes, seagrasses and oyster reefs, among others—provide a host of ecosystem services that are critical for the health of coastal ecosystems (Costanza et al. 1997, Beck et al. 2001, Barbier et al. 2011). These habitats provide structure, substrate, and shelter for a variety of species of ecological and commercial importance (Heck and Thoman 1984, Beck et al. 2001, Heck et al. 2008, Barbier et al. 2011, Grabowski et al. 2012). In some cases, declines in coastal habitats have been associated with the collapse of commercial fisheries, such as the collapse of the bay scallop fishery following a dramatic loss of eelgrass in the northeast U.S. in the 1930s (Beck et al. 2001, Orth et al. 2006). Coastal habitats can improve water quality through direct phytoplankton removal, nutrient uptake, and sediment deposition (Cerco and Noel 2005, Lindahl et al. 2005, Barbier et al. 2011, Grabowski et al. 2012). Structured habitats can attenuate wave energy which stabilizes sediments and reduces coastal erosion (Piazza et al. 2005, Barbier et al. 2011). Some systems provide raw materials, such as limestone mined from coral reefs (Moberg and Folke 1999, Barbier et al. 2011). Coastal habitats provide a number of ecosystem services which are crucially important to the health and function of estuaries and coastal communities, yet coastal areas are one of the most heavily degraded areas in the marine environment (Lotze et al. 2006, Orth et al. 2006, Halpern et al. 2008, Barbier et al. 2011).

Coastal areas are epicenters for human development and civilization, and after decades of intensive use and modification, nearly all coastal habitats have been impacted by human actions (Halpern et al. 2008, Bulleri and Chapman 2010, Chapman

and Underwood 2011). Over 60% of seagrasses and wetlands have been lost worldwide, and shellfish habitat losses range from 60-90% (Lotze et al. 2006, Orth et al. 2006, Beck et al. 2011). Loss of these coastal habitats can be directly attributed to human actions, which include direct habitat modification, eutrophication and sedimentation of coastal areas, increases in the spread of disease and invasive species, and overharvesting of species (Silliman and Bertness 2004, Lotze et al. 2006, Orth et al. 2006, Beck et al. 2011, Chapman and Underwood 2011, Deegan et al. 2012). As human population near the coast continues to rise, an increase in recreational, commercial, residential, and shipping activities is expected (Chapman and Underwood 2011), which will further contribute to the rapid degradation of coastal ecosystems and further loss of ecosystem services (Scavia et al. 2002, Orth et al. 2006, Beck et al. 2011).

Oyster reefs are among the most degraded coastal habitats and have lost approximately 90% of their global extent (Lotze et al. 2006, Beck et al. 2011). In the U.S., the extent of the eastern oyster (*Crassostrea virginica*) has decreased by > 50% and is considered to be functionally extinct in some regions of the northeast (Kirby 2004, Lotze et al. 2006, Beck et al. 2011, Zu Ermgassen et al. 2012). Oysters were one of the first coastal invertebrates to experience declines due to their high value as a commercial fishery, destructive fishing practices, and overharvesting (Kirby 2004, Lotze et al. 2006, Beck et al. 2011). The first signs of decline in the U.S. oyster fishery occurred in the late 19<sup>th</sup> century in New England (Kirby 2004). Overexploitation of oysters continued throughout the east coast and Gulf of Mexico (Kirby 2004, Beck et al. 2011, Zu Ermgassen et al. 2012). In addition to overharvesting, decreases in water

quality and spread of disease have also compounded the decline of oyster stocks in the U.S. (Kirby 2004, Powell et al. 2009a, Beck et al. 2011, Zu Ermgassen et al. 2012).

Oyster reefs are valued for their economic importance as a commercial fishery, as well as the ecosystem services that these reefs provide (Grabowski and Peterson 2007, Beck et al. 2011, Grabowski et al. 2012). Grabowski et al. (2012) estimated that the average yearly value of commercial oyster harvest was between \$880 and \$17,072 per hectare, and the combined commercial landings of oysters in the U.S. east coast were valued at over \$400M between 2010 and 2012 (NOAA 2014). Additionally, oyster reefs provide a suite of ecosystem services which have been valued at a combined yearly average value of \$5,508 to \$99,421 per hectare (excluding commercial harvesting value) (Grabowski et al. 2012). Ecosystem services provided by oyster reefs include improving water quality through phytoplankton (Nelson et al. 2004, Cerco and Noel 2005, Newell et al. 2007), shoreline protection and reduction of shoreline erosion (Piazza et al. 2005, Grabowski and Peterson 2007), provision of habitat for benthic infauna (Lenihan et al. 2001, Rodney and Paynter 2006, Grabowski et al. 2012), and enhancing production of transient fish and mobile crustacean species (Peterson et al. 2003, Grabowski and Peterson 2007, Powers et al. 2009).

As ecosystem engineers, oysters provide complex structure and habitat in estuarine areas that is colonized by a diverse community (Wells 1961, Lenihan et al. 2001, Rodney and Paynter 2006, Harwell et al. 2011). Vertebrate and invertebrate species living on oyster reefs are either residents that spend the majority of their life on the reef, or transient, which utilize the reef as a refuge or foraging ground for part of their life (Wells 1961, Lenihan et al. 2001, Grabowski 2004, Yeager and Layman 2011). Oyster

reef-associated fauna include some species of shrimp, polychaete, mussels, xanthid crabs such as mud crabs, juvenile blue crabs (*Callinectes sapidus*), porcelain crabs, and small fish species such as gobies and blennies (Lenihan et al. 2001, Grabowski 2004, Yeager and Layman 2011). Transient fish species that use the oyster reef vary regionally; some common species found in the southeastern U.S. and Gulf of Mexico include spot (*Leiostomus xanthurus*), Atlantic croaker (*Micropogonias undulatus*), Atlantic spadefish (*Chaetodipterus faber*), Gulf toadfish (*Opsanus beta*), oyster toadfish (*Opsanus tau*), grey snapper (*Lutjanus griseus*) and southern flounder (*Paralichthys lethostigma*) (Wells 1961, Lehnert and Allen 2002, Grabowski 2004, Plunket and La Peyre 2005).

In addition, oyster reefs are of great importance in coastal areas as they provide a link between reef-associated benthic organisms and highly mobile transient species in estuaries (Lenihan et al. 2001, Peterson et al. 2003, Grabowski et al. 2012). Invertebrate fauna on oyster reefs have been found to be a main prey item of transient fish species; created *C. ariakensis* reefs in the Yangtze River (China) support higher trophic levels compared to other structured habitat due to the invertebrate fauna that colonizes the reef and is subsequently preyed upon by transient species (Quan et al. 2012). In southeast Florida, Yeager and Layman (2011) found that the crested goby (*Lophogobius cyprinoides*) are exclusively dependent on prey resources found on the oyster reef and are also an important resource predatory fish. These gobies transfer production from reef-associated fauna to higher trophic level species that forage on the oyster reef (Yeager and Layman 2011). Oyster reefs sustain a diverse vertebrate and

invertebrate food web, which provides a crucial link to sustaining higher trophic level transient species (Lehnert and Allen 2002, Peterson et al. 2003).

Due to the value of ecosystem services provided by oyster reefs the number of projects and monetary effort invested towards restoration has dramatically increased in the past several years (Grabowski et al. 2012, Zu Ermgassen et al. 2012). Although initial oyster restoration efforts were focused primarily on rebuilding the commercial oyster fishery, current restoration efforts focus on restoring all of the ecosystem services oyster reefs provide (Coen and Luckenbach 2000, Peterson et al. 2003, Beck et al. 2011, Grabowski et al. 2012, Grizzle and Coen 2013). Projects may have different restoration goals, and commonly increasing the density, biomass, and biodiversity of fish species that utilize the reef has been used as a restoration goal and metric of restoration success (Coen and Luckenbach 2000, Peterson et al. 2003, Beck et al. 2011, Grabowski et al. 2012, Grizzle and Coen 2013, Baggett et al. 2014).

Oyster reef restoration increases structured habitat and prey foraging grounds, leading to enhanced secondary production (Lenihan et al. 2001, Peterson et al. 2003, Grabowski et al. 2005, Rodney and Paynter 2006, Grabowski et al. 2012). Peterson et al. (2003) reviewed six studies that quantified fish and crustacean abundance in restored oyster reefs and found that the densities of 19 species of fish and large crustaceans were enhanced by the presence of a restored oyster reef, resulting in an annual increase in fish production of 2.57 kg per 10 m<sup>2</sup> of oyster reef (Peterson et al. 2003). Lenihan et al. (2001) found that species richness and abundance were higher on oyster reefs (restored or natural) than on sand-bottom habitat. Although restored oyster reefs increase prey foraging grounds (Grabowski et al. 2005, Tolley and Volety 2005,



Rodney and Paynter 2006), transient species that benefit from the restored oyster reef also depend on other coastal habitats for prey resources (Lenihan et al. 2001, Yeager and Layman 2011, Quan et al. 2012). Yeager and Layman (2011) found that the diet of transient predatory grey snapper was composed of a combination of prey from the oyster reef habitat and adjacent mangrove habitat. As juveniles, the grey snapper feed almost entirely on oyster reef fauna, however as subadults a greater proportion of their diet was derived from mangrove associated fauna (Yeager and Layman 2011). Quan et al. (2012) found that while a created oyster reef supported most of the basal resources for a robust food web, resources from a nearby salt marsh also comprised part of resources that supported transient carnivorous fish.

Experimental studies have shown that restoration of oyster reefs may be a successful strategy for increasing secondary production (Lenihan et al. 2001, Peterson et al. 2003, Tolley and Volety 2005), but predicting the effects of restoration on the fish community remains a challenge. Models that track energy flow through an ecosystem increase our understanding of connections among species and trophic guilds that use oyster reefs (Ulanowicz and Tuttle 1992, Hobbs 2007, Powell et al. 2009b). Such models may provide the building blocks to understanding the effects of restoration alternatives on secondary production from oyster reef restoration.

Mathematical models provide an alternative to experimental approaches that can be adjusted to site-specific applications and used to make projections regarding ecosystem-wide changes. For example, Fulford et al. (2010) used a trophic-simulation carbon budget model based on bioenergetics principles predict the potential impact of increasing oyster biomass in the Chesapeake Bay by assessing energy transfer

between trophic groups. Increasing oyster biomass decreased phytoplankton and pelagic fish biomass, while benthic and reef-associated fish biomass increased (Fulford et al. 2010). Fulford et al. (2010)'s simulation model allowed the authors to evaluate the potential impacts that oyster restoration could have in the Chesapeake Bay ecosystem, with a focus on water quality impacts, and could be used by restoration managers to set possible targets for restoration projects (Fulford et al. 2010).

A dynamic trophic model to understand energy flows in a restored oyster reef could be used to analyze the relationships among trophic groups and assess possible effects from restoration strategies. The objective of this project was to create an ecosystem model that simulated energy transfers through multiple trophic levels in a restored oyster reef system. The model aimed to predict ecosystem level changes in biomass that may occur from restoration activities, specifically the model addressed the following questions: (1) how will a restoration scenario that leads to a change in the mean oyster biomass affect (i.e. density of individuals) the biomass of transient fish species?; (2) how will a restoration strategy favoring individual or population-level oyster growth rate affect the biomass of transient fish species?; and (3) how will increasing diet dependence of transient fish species on oyster reef derived fauna affect their biomass?

## Methods

### *Functional Groups*

The model used functional groups representative of species commonly found in an oyster reef ecosystem which were grouped based on similar diets and life history characteristics. Functional groups of the model consisted of oysters, on-reef resident invertebrates, blue crabs, reef-resident fish, transient non-piscivorous fish, and transient piscivorous fish (Figure 1). In addition to the six functional groups representing organisms, a detritus/POC pool and outside carbon pool representing prey sources obtained by transient individuals outside of the oyster reef system were also modeled.

Oysters were considered their own functional group, as they grow in vertical and horizontal aggregations that provide biogenic structure for other organisms to settle on and inhabit (Wells 1961). On-reef invertebrates were considered a functional group and consist of invertebrate species that colonize the oyster reef including suspension-feeders, deposit-feeders, or carnivores (Fulford et al. 2010). These species include annelids, isopods, amphipods, gastropods, decapods, and other invertebrates that live within the reef matrix, settle on oyster shells, or aggregate on the reef for feeding (Wells 1961). Blue crabs were also selected as a separate functional group due to their transient nature, their documented high consumption of juvenile oysters, and their commercial importance (Eggleston 1990).

Fish were separated into three different functional groups: reef-resident fish, transient non-piscivorous fish, and transient piscivorous fish, each modeled independently. Reef-resident fish are species that recruit to oyster reefs and spend most of their life living in the structure provided by the oyster reef while feeding on small

invertebrates or POC (James-Pirri et al. 2001, Peterson et al. 2003); this group included gobies and blennies (Wells 1961, Fulford et al. 2010). Transient non-piscivorous fish are species that prey mainly on benthic invertebrates, while transient piscivorous fish feed primarily on small fish from the other two fish functional groups. The presence of an oyster reef may lead to an increase in the biomass of both transient fish through an increase in prey foraging grounds (Peterson et al. 2003). Due to their transient nature, these species only spend a portion of their time feeding in and around the oyster reefs before moving to other foraging grounds (Lehnert and Allen 2002, Peterson et al. 2003, Yeager and Layman 2011). Transient non-piscivorous fish may include sheepshead, black drum, and croaker (Zimmerman et al. 1989, Plunket and La Peyre 2005). Transient piscivorous fish may include southern flounder, spotted seatrout, and red drum (Zimmerman et al. 1989, Peterson et al. 2003, Plunket and La Peyre 2005). Planktivorous fish were not included in the model since a restored oyster reef is not likely to have a direct and spatially localized effect on their growth and biomass (Peterson et al. 2003).

### ***Bioenergetic Model***

The model is a dynamic bioenergetic model using a set of ordinary differential equations. Bioenergetics is based on the law of thermodynamics that energy cannot be created or destroyed and is the basis for tracking energy through an individual organism (Hanson et al. 1997). By linking species-specific bioenergetic models, the same concept can be used to follow energy through the system using functional groups representative of species in a system. This model tracked energy as grams of carbon

(gC) using a one day time step, and input and output equations for consumers were based on bioenergetics models and concepts from Hanson et al. (1997), Bartell et al. (1999), Naito et al. (2002), Megrey et al. (2007), and Fulford et al. (2010).

The model used representative functional groups found in an oyster reef ecosystem (Figure 1). The growth of oysters and on-reef invertebrates was modeled as logistic growth, while the growth of consumer functional groups was based on a set of inputs and outputs such that growth over time is:

$$\frac{dB}{dt} = \text{Consumption} - \text{Respiration} - \text{Metabolic Losses} - \text{Natural Mortality} - \text{Predation} \quad (1)$$

Most studies that have used a bioenergetic model to estimate oyster biomass have applied an oyster filtration rate with the goal of understanding the impact of oyster biomass on water quality (Cerco and Noel 2005, Wang et al. 2008, Fulford et al. 2010). The objective of this model was to understand the contribution of restored oyster reefs to fish secondary production, which occurs primarily through the accumulation of prey items on the oyster reef (Wells 1961, Peterson et al. 2003). Soniat et al. (2012) developed a model to calculate a sustainable oyster harvest estimate and described oyster growth as a change in length over time according to the von Bertalanffy function describing somatic growth, which is then converted to oyster density and mass.

Similar to Soniat et al. (2012), this study decoupled the model from phytoplankton biomass, and aimed to describe oyster biomass independent of primary productivity. However, rather than using the von Bertalanffy growth equation, I described population growth as a Gompertz growth process reaching a carrying capacity. Although a typical logistic growth function was initially considered to model oyster population growth, a Gompertz function more closely resembles the growth of oyster biomass. The logistic

growth function and the Gompertz growth function both have similar properties representing biological growth and no disadvantage exists when using the Gompertz growth over the logistic growth function (Winsor 1932, Tsoularis and Wallace 2002). A comparison of the logistic growth function and Gompertz growth function to represent oyster population growth can be found in Appendix I. Oyster growth is described as:

$$\frac{dB_o}{dt} = r_o \times B_o \times [\log(K_o) - \log(B_o)] - Pred_o \quad (2)$$

where  $B_o$  is the total oyster biomass ( $\text{gC} \cdot \text{m}^{-2}$ ),  $r_o$  is the growth rate of oysters ( $\text{gC} \cdot \text{gC}^{-1} \cdot \text{day}^{-1}$ ),  $K_o$  is the carrying capacity of oysters ( $\text{gC} \cdot \text{m}^{-2}$ ), and  $Pred_o$  are losses due to predation from other functional groups. By using a function that incorporates a growth rate term ( $r_o$ ) and a density-dependent term ( $K_o$ ), the model incorporates the effects that resources such as, substrate and recruits, and environmental conditions such as, salinity and temperature, may have on individual or population-level growth (Wang et al. 2008, Brumbaugh and Coen 2009, Knights and Walters 2010, Kim et al. 2013).

Since the on-reef invertebrate functional group represents a wide range of invertebrate species their biomass was described as a proportion of the oyster biomass. Fulford et al. (2010) used a similar approach describing the assemblage of on-reef invertebrates as a proportion of the oyster biomass. The growth of on-reef invertebrates is described as:

$$\frac{dB_i}{dt} = B_i \times \left[1 - \frac{B_i}{B_o \times IO}\right] \times f(T) - Pred_i \quad (3)$$

where  $B_i$  is the total on-reef invertebrate biomass ( $\text{gC} \cdot \text{m}^{-2}$ ),  $B_o$  is the oyster biomass ( $\text{gC} \cdot \text{m}^{-2}$ ),  $IO$  is a ratio of invertebrate biomass to oyster biomass (unitless),  $f(T)$  is a temperature dependence function, and  $Pred_i$  are losses due to predation. This

equation describes on-reef invertebrates as growing logistically, with a carrying capacity that is proportional to oyster biomass at each time step (with some temperature dependent effect on total on-reef invertebrate biomass) and losses due to predation from other functional groups.

The growth of consumer functional groups was described as energy gained from consuming prey biomass, minus energy lost from respiration processes, metabolic energy losses due to consumption, natural mortality rates, and predation from other functional groups. Consumer growth was based on the following equation:

$$\frac{dB_j}{dt} = B_j (C_j \times [1 - Mloss_j] - [R_j \times f(T)] - Mort_i) - Pred_j \quad (4)$$

where  $B_j$  is the biomass of consumer group  $j$  ( $gC \cdot m^{-2}$ ),  $C_j$  is the per capita consumption rate ( $gC \cdot m^{-2} \cdot day^{-1}$ ),  $R_j$  are losses due to respiration ( $gC \cdot gC^{-1} \cdot day^{-1}$ ),  $f(T)$  is a temperature dependence function (unitless; ranging 0-1),  $Mort_i$  is natural mortality rate ( $day^{-1}$ ),  $Mloss_j$  are metabolic losses from consumption ( $day^{-1}$ ), and  $Pred_j$  are losses due to predation ( $gC \cdot m^{-2} \cdot day^{-1}$ ).

Daily consumption rate for consumer  $j$  ( $C_j$ ) is defined as:

$$C_j = Cmax_j \times f(T) \times \frac{\sum_i w_{ji} \times e_j \times B_i}{B_j + \sum_i w_{ji} \times B_i} \quad (5)$$

where  $Cmax_j$  is the maximum consumption for consumer  $j$  ( $gC \cdot gC^{-1} \cdot day^{-1}$ ),  $f(T)$  is a temperature dependence function (unitless; ranging 0-1),  $B_j$  is the biomass of consumer  $j$  ( $gC \cdot m^{-2}$ ),  $w_{ji}$  is the prey preference of consumer  $j$  for prey  $i$  (unitless; ranging 0-1),  $e_j$  is the assimilation efficiency of consumer  $j$ , and  $B_i$  is the biomass of prey  $i$  ( $gC \cdot m^{-2}$ ) (Naito et al. 2002).

Predation losses for functional group  $j$  was defined as:

$$Pred_j = \frac{\sum_k C_{max_k} \times f(T) \times w_{kj} \times B_k}{B_k + (w_{kj} \times B_j) + \sum_k w_{kz} \times B_z} \quad (6)$$

where  $C_{max_k}$  is the maximum consumption for predator  $k$  ( $gC \cdot gC^{-1} \cdot day^{-1}$ ),  $f(T)$  is a temperature dependence function (unitless; ranging 0-1),  $w_{kj}$  is the preference of consumer  $k$  for prey  $j$  (unitless; ranging 0-1),  $B_k$  is the biomass of predator  $k$  ( $gC \cdot m^{-2}$ ),  $B_j$  is the biomass of prey  $j$  ( $gC \cdot m^{-2}$ ),  $w_{kz}$  is the preference of consumer  $k$  for prey items  $z$  (which includes all other prey items for predator  $k$ ) (unitless; ranging 0-1), and  $B_z$  is the biomass of all other prey items  $z$  for predator  $j$  ( $gC \cdot m^{-2}$ ) (Naito et al. 2002).

The temperature dependence function  $f(T)$  is used to simulate the effects of changing water temperature on the metabolic processes of different functional groups (Hanson et al. 1997). Temperature dependence is defined as:

$$f(T) = v(T)^{VX} \times e^{VX(1-v(T))} \quad (7)$$

where,

$$v(T) = \frac{T_{max} - T_{amb}}{T_{max} - T_{opt}} \quad (8)$$

$VX$  is a scaling parameter relating  $T_{opt}$ ,  $T_{max}$ , to the rate at which the function  $f(T)$  increases over relatively low water temperature,  $T_{max}$  is the upper lethal water temperature for each functional group,  $T_{opt}$  is the optimum water temperature where the maximum rate for a metabolic process is observed, and  $T_{amb}$  is the ambient water temperature predicted for the model. Different  $T_{opt}$  parameters were defined for respiration ( $T_{optR}$ ) and consumption ( $T_{opt}$ ) processes for each functional group, while  $T_{max}$  was defined as one parameter for each functional group.

Functions for detritus/POC and outside carbon are described in Appendix I. The model was constructed the *deSolve* package (Soetaert et al. 2010) in R Studio (R Core Team 2013) and can be found in Appendix II.



## ***Data Acquisition***

Model projections were evaluated using data provided from an oyster restoration project in Sister (Caillou) Lake, Louisiana (La Peyre et al. 2014). Sister Lake is an open-water brackish system with abundant oyster beds (Casas et al. 2015). Six experimental oyster reefs were constructed using shell-clutch in March 2009, and post-restoration monitoring was performed through March 2012. Monitoring included sampling of oyster recruitment, oyster growth, and community composition of highly mobile fish and crustacean species on the reefs (La Peyre et al. 2014). Detailed results from different monitoring activities can be found in La Peyre et al. (2014) and Casas et al. (2015).

Sampling of the restored reefs occurred 3-4 times annually and was summarized as average biomass per month for each functional group. Oyster biomass estimates were taken from oyster whole weights and converted to gC using a 1:50 dry meat to whole weight ratio (La Peyre *person comm.*), and a 0.5:1 dry meat to gC ratio (Cerco and Noel 2005). Blue crab estimates were obtained from seine and gillnet samples, and biomass was estimated using a 0.10:1 gC to whole weight ratio (Salonen et al. 1976, Ricciardi and Bourget 1998). Reef-resident fish estimates were obtained using embedded trays, since the reef-resident fish community is best captured in this manner, while estimates for transient fish (non-piscivorous and piscivorous) were taken from gillnets (Plunket and La Peyre 2005). Biomass for fish was estimated using a 0.10:1 gC to grams of whole weight ratio (Nixon et al. 1986). Fish species collected in the study were divided into functional groups based on life-history characteristics and are presented in Table 1 (Peterson et al. 2003, Kells and Carpenter 2011, Yeager and Layman 2011, Quan et al.

2012). The functional group biomass was considered the combined weight of all species in a functional group for each independent sampling effort.

## ***Parameter Selection***

### ***Bioenergetic Parameters***

Literature values were used for physiological parameters to describe consumption, growth, and respiration processes (Table 2). If necessary, parameters were adjusted, within biologically reasonable boundaries, until a close agreement between model output and empirical data was achieved.

Specific diet distribution parameters for consumers on oyster reefs were not available in the literature, and values for diet distribution were based on a broad literature research of diet composition from similar species and species-specific studies (Table 3). Diet distribution was derived from information on diet composition of species belonging to the distinct functional groups (Kells and Carpenter 2011), previous models describing diet composition of functional groups (Bartell et al. 1999, Peterson et al. 2003, Fulford et al. 2010), species-specific literature regarding diet composition (Hettler Jr 1989, Lipcius et al. 2007, Brown et al. 2008), and studies looking at gut-content and isotopic analysis of species found on oyster reefs (Lenihan et al. 2001, Yeager and Layman 2011, Quan et al. 2012).

Initial biomass values for oysters and on-reef invertebrates were set at  $1 \text{ gCm}^{-2}$ , blue crab and reef-resident fish species starting biomass values were selected to be close to the lower biomass estimates obtained from the restoration study, and starting biomass estimates for transient fish communities were chosen to be within the values obtained

for monthly biomass sampling since the restoration study revealed no significant increase over time for transient species (La Peyre et al. 2014).

### *Temperature Forcing Function*

Water temperature values taken at 15-minute intervals for a 3.5-year period were obtained from the USGS Station LDWF/USGS 07381349 at Sister Lake, LA. Continuous water temperatures for the area were plotted as Julian days and daily water temperatures for the model were described using a sine function (Figure 2).

### **Model Evaluation**

#### *Model Verification*

The model was validated against observed field data from the restoration study as a diagnostic to check for sources of error within the model (Rice and Cochran 1984). Partitioning of the mean squared error (MSE) was used to evaluate the model for systematic biases. MSE partitioning is done by comparing model predicted values ( $P_i$ ) and field-observed values ( $A_i$ ) and measuring the variance of these points from a perfect model (a 1:1 regression line) (Rice and Cochran 1984),

$$MSE = \frac{1}{n} \sum (P_i - A_i)^2 \quad (9)$$

$$MSE = (\bar{P} - \bar{A})^2 + (S_P - rS_A)^2 + (1 + r^2)S_A^2 \quad (10)$$

$$1 = \frac{(\bar{P} - \bar{A})^2}{MSE} + \frac{(S_P - rS_A)^2}{MSE} + \frac{(1 + r^2)S_A^2}{MSE} \quad (11)$$

$$\text{MSE} = \text{MC} + \text{SC} + \text{RC} \quad (12)$$

The MSE is divided into its three components, the mean component (MC), which explains the bias due to differences in the predicted and observed values, the slope component (SC), which measures the error from the slope deviating from unity, and the residual component (RC), which measures the proportion of MSE due to random error. Ideally  $\text{MSE} = 0$ , which indicates a perfect prediction, when this is not possible the best fit distribution would be  $\text{SC}=0$ ,  $\text{MC}=0$ , and  $\text{RC}=1$ , indicating that errors in the model are not systematic (Rice and Cochran 1984).

### *Sensitivity Analysis*

A sensitivity analysis was used to determine which model parameters contribute the most variability to the model output. This analysis can be used to identify the parameters that contribute the most variation and target them for further study to improve future models (Shaeffer 1980). Sensitivity analysis of model parameters was done using the Flexible Modeling Environment package in R (Soetaert and Petzoldt 2010).

The sensitivity analysis tested the effect of a change in each individual parameter on a particular sensitivity variable (Hamby 1994). Parameters were varied one-at-a-time by sampling from a random uniform distribution with a range of  $\pm 75\%$  of each parameter's calibration value (Tables 2 and 3). The sensitivity variables were selected as the biomass of transient non-piscivorous fish and transient piscivorous fish at day 1281 (summer of year 3). Since the objective of the model was to understand the impact of

oyster restoration on fish communities, choosing a transient fish functional group during the summer time allowed us to understand what parameters had the most influence on these particular groups of interest.

Two methods were selected to measure parameter sensitivity relative to the selected sensitivity variable (D), a Sensitivity Index and a Relative Deviation method. While each sensitivity analysis method would produce a different ranking of the model parameters, the importance is the parameters that are consistently ranked higher, meaning that a variation in the parameter produces a larger variation in the sensitivity variable (Hamby 1994). The sensitivity analyses are described below:

1. Sensitivity Index (SI), which calculates the percent difference in the sensitivity variable when varying each parameter over the selected range (Hamby 1994),

$$SI = \frac{D_{max} - D_{min}}{D_{max}} \quad (13)$$

2. Relative deviation method (RD), is a coefficient of variation which measures the ratio of the standard deviation to the mean of the sensitivity variable and provides an indication of contribution to the variability in the model sensitivity variable (Hamby 1994),

$$RD = \frac{S_D}{\bar{D}} \quad (14)$$

### ***Model Scenarios***

The fully parametrized model was used to examine effects of possible oyster reef restoration scenarios on biomass of secondary consumers. Oyster restoration scenarios were simulated by making changes to the oyster population growth function

and by making changes to the diet distribution of transient species. Changes in biomass of different functional groups were quantified and compared to the baseline model.

### *Scenario 1: Changes to the Oyster Carrying Capacity*

The first scenario focused on changes to the oyster carrying capacity ( $K_O$  in equation 2). Oyster populations have been described as having stable carrying capacities that may be influenced by both the environment and human actions (Powell et al. 2009). In Delaware Bay during the 1953-2005 period the oyster population went through fluctuations in abundances and the basin wide carrying capacity experienced two distinct stable carrying capacities with a 4X difference in abundance between the 1970s and 1990s (Powell et al. 2009b). Oyster restoration projects often have a mean oyster abundance target, which could reflect a historic or previously observed abundance such as the Chesapeake Bay 2000 Agreement which called for a minimum tenfold increase in oyster biomass (EPA 2000). The oyster carrying capacity scenario was aimed at understanding how changes in possible restoration techniques which affect the mean oyster biomass could impact the fish community.

### *Scenario 2: Changes to the Oyster Growth Rate*

The second scenario was related to changes in the oyster growth rate ( $r_O$  in equation 2). The individual oyster growth rate may vary due to environmental conditions, such as changes in salinity, dissolved oxygen, or temperature (Kraeuter et al. 2007, Wang et al. 2008). And the overall oyster population growth may vary due to characteristics of the population, such as variations in recruitment rate, as well as outside influences, such as

fishing induced population mortality (Powell et al. 2009b, Knights and Walters 2010). The overall population growth of a restored oyster reef may be affected by environmental conditions, and placement of the restoration project in regards to localized environmental conditions may have an effect on overall oyster population growth and success (Powers et al. 2009, Casas et al. 2015). This scenario was intended to understand how external factors (local or regional environmental conditions) representative of either favorable or unfavorable restoration placement might influence the oyster growth rate and subsequent impact on the fish community.

### *Scenario 3: Changes to Dependence on Oyster Reef Derived Prey*

The third scenario was related to changes in the diet composition of transient fish and their dependence on oyster reef derived prey ( $w_{ij}$  in equation 5). Transient species in estuaries often forage for prey in multiple habitats within the same estuary, and some fish species have been found to undergo ontogenetic shifts in their diet preference (Heck et al. 2008, Yeager and Layman 2011, Quan et al. 2012). Enhancement of secondary production resulting from oyster reef restoration has been shown to be dependent on the location of the oyster reef in relation to adjacent habitats, with a significant enhancement from pre-restoration levels observed in reefs restored near mud-bottom habitats as opposed to seagrasses or salt marshes (Grabowski et al. 2005, Geraldi et al. 2009). This has been attributed to the functional redundancy of oyster reefs and other coastal habitats in their ability to provide refuge and prey foraging grounds (Grabowski et al. 2005). While the availability of and connectivity among different coastal habitats has been shown to be of great importance in estuarine

systems (Heck and Thoman 1984, Beck et al. 2001, Heck et al. 2008), it has been difficult to quantify the diet distribution of transient species among these habitats (Lenihan et al. 2001, Yeager and Layman 2011, Quan et al. 2012). This model assumed that 50% and 45% of the diet of transient non-piscivorous fish and transient piscivorous fish, respectively, was derived from oyster reef prey (oysters, on-reef invertebrates, blue crabs, and reef-resident fish). The third scenario recreated two diet changes in which the dependence of oyster reef derived prey for transient fish species was increased:

1. Diet 1: the dependence on oyster reef derived prey for transient non-piscivorous fish was increased to 80% while transient non-piscivorous fish remained the same, (Figure 3) and
2. Diet 2: the dependence on oyster reef derived prey for transient non-piscivorous fish and transient piscivorous fish was increased to 80% and 75%, respectively (Figure 3).

This scenario was aimed at understanding how transient fish would respond to a restoration project if they were more dependent on the oyster reef for prey foraging grounds than on other habitats.



## Results

### ***Model Evaluation***

#### *Model Dynamics and Comparison with Empirical Data*

Predicted mean monthly oyster biomass followed a similar pattern to field-observed data, and maximum predicted oyster biomass values are within one standard error of the two highest field-observed oyster biomass measurements (Figure 4a). During the first two years, predicted oyster biomass is higher than field-observed biomass, but by summer of the third year predicted oyster biomass plateaus between 400-440 gCm<sup>-2</sup>, compared to observed oyster biomass estimates of 331 ± 47 gCm<sup>-2</sup> and 450 ± 56 gCm<sup>-2</sup> during the winter of the year 2 and spring of year 3, respectively. Predicted oyster maximum biomass values are lower than the model selected carrying capacity (600 gCm<sup>-2</sup>) due to predation from other functional groups. Since on-reef invertebrate biomass is modeled as a fixed proportion of oyster biomass, on-reef invertebrates have an identical growth pattern as oysters, and their biomass is half of the predicted oyster biomass at all times ( $IO = 0.5$ ; Table 2).

Predicted mean monthly biomass values for fish functional groups exhibited seasonal patterns corresponding to changes in predicted water temperature (Figures 4b-d). Predicted biomass maxima occurred during early spring and fall when modeled water temperature was near 28°C, which is the optimum temperature for fish functional groups to achieve maximum consumption (27°C for reef-resident fish and transient non-piscivorous fish, and 28°C for transient piscivorous fish [Table 2]). Seasonal variation is not indicative of net fish movement into and out of the estuary; rather it reflects that

during spring and fall the predicted water temperature is at an optimum range for consumption and fish growth.

Model predicted reef resident fish biomass was relatively low the first year and increased after two years, reaching values ranging between 20-60 gCm<sup>-2</sup> after the winter of year 2 (Figure 4b). On-reef invertebrates composed 60% of reef-resident fish diet and the large increase in reef-resident fish biomass after year 2 was a result of on-reef invertebrates reaching their peak biomass. Observed field data for reef-resident fish is only available for 1.5 years post-restoration (La Peyre et al. 2014) and predicted model estimates during the first 1.5 years are within one standard error of field-observed biomass, which ranged from  $0.061 \pm 0.04$  gCm<sup>-2</sup> to  $4.47 \pm 4.19$  gCm<sup>-2</sup>.

Model predicted values for both transient fish functional groups exhibited some variation during the first year, but by the end of the second year, biomass values appear to have stabilized (Figure 4c-d). Forty percent of the diet of transient non-piscivorous fish was composed of oysters and on-reef invertebrate, and the biomass for this transient group stabilized near the same time that oysters and on-reef invertebrates reached their maximum values. This suggests there was insufficient prey available during years 1 and 2 to support the selected initial biomass for transient non-piscivorous fish. Transient piscivorous fish exhibited a steady increase until stabilizing near the end of year 2 (Figure 4c). Fifty five percent of the diet for transient piscivorous fish was derived from an outside source, which dampened the effects of changes in oyster reef fauna on their biomass. Field-observed data for transient non-piscivorous fish biomass ranged from  $4.47 \pm 2.04$  gCm<sup>-2</sup> to  $33.4 \pm 9.90$  gCm<sup>-2</sup>, and for transient piscivorous fish from  $1.84 \pm 1.30$  gCm<sup>-2</sup> to  $12.77 \pm 5.36$  gCm<sup>-2</sup>, reflecting the natural variability in the

transient fish community. Predicted transient non-piscivorous and piscivorous fish biomass values were within the range of field-observed values, except for three values during year 1 for the non-piscivorous fish, which were higher than model predicted values or any other field-observed biomass values (Figure 4d).

### *Model Verification*

Partitioning of MSE analysis between field-observed and model-predicted values for transient non-piscivorous fish indicated that there was some variance due to differences in the observed and predicted values, but most of the variance was due to random errors (MC = 0.34, SC=0.24, RC=0.49) (Figure 5a). The variability in the MC and SC components are driven due to the three high field-observed values during year 1. Partitioning of MSE analysis for transient piscivorous fish indicates that most of the variance in model predictions was due to random error (MC = 0.13, SC=0.008, RC=0.95) (Figure 5b).

### *Sensitivity Analysis*

The sensitivity index (SI) and relative deviation index (RD) showed similar parameter sensitivity ranking for both transient fish functional groups' biomass at day 1281. Parameters controlling the growth of these functional groups (those used in Equations 4 and 5 except for diet distribution parameters  $w_{ij}$ ) had the most effect on variability on their biomass at day 1281 (Tables 4 and 5). Temperature related parameters (Equation 8) ranked in the top ten of both indices since they scale consumption and respiration processes. The optimum temperature for maximum consumption ( $T_{opt}$ ) had the highest

sensitivity rating for both transient functional groups. Temperature related parameters were obtained from species-specific studies and the selected values are reflective of peer-reviewed literature (Table 2). Parameters for which peer-reviewed literature was limited did not appear to have a large effect on the biomass of transient functional groups.

### **Scenario Analysis**

#### *Scenario 1: Changes to the Oyster Carrying Capacity*

Changes to the oyster carrying capacity produced proportional changes of oyster, on-reef invertebrate, and reef-resident fish biomass (Figures 6 and 7). A  $\pm 50\%$  change to the oyster carrying capacity produced a nearly equal change in biomass for the three functional groups: oyster and on-reef invertebrates biomass changed  $\pm 50\%$  by the middle of year two, and reef-resident fish biomass changed  $\pm 50\%$  biomass change by the end of year three (Figure 6 and 7). Doubling the oyster carrying capacity had comparable impacts on biomass of these functional groups, producing a doubling of oysters and on-reef invertebrate biomass by year 2, and doubling reef-resident fish biomass by the end of year 3 (Figure 6).

Varying oyster carrying capacity produced moderate changes in the biomass of transient fish groups, which were most obvious by the end of years 2-3 (Figure 6c-d and 7c-d). A  $\pm 50\%$  change in oyster carrying capacity produced a  $\pm 47\%$  change in transient non-piscivorous fish biomass by the end of year five (Figure 6c and 7c). Transient non-piscivorous fish consume 40% of their diet from oyster reef sources, thus a 50% change in its diet source resulted in a proportional impact on their biomass. Transient

piscivorous fish biomass experienced a  $\pm 28\%$  change in biomass by the end of year five following  $\pm 50\%$  change to oyster carrying capacity (Figure 6d and 7d). Since transient non-piscivorous fish have a lower dependence on oyster reef fauna, changes to the oyster carrying capacity had a moderate effect on their biomass. A doubling of the oyster carrying capacity produced a near doubling of transient non-piscivorous fish biomass by year 5, while transient piscivorous fish increased 50% by the end of year five.

Reef-resident fish and transient non-piscivorous fish exhibited percentage biomass changes nearly identical to percentage changes in the oyster carrying capacity after five years. These two groups are directly dependent on oyster reef fauna and changes to the carrying capacity directly affected their biomass. Transient piscivorous fish consume organisms that predate on oyster reef fauna, but do not directly predate on oyster reef fauna. Thus, percentage changes to the oyster carrying capacity produced moderate percentage changes on the biomass of this fish functional group.

### *Scenario 2: Changes to the Oyster Growth Rate*

Increases to the oyster growth rate produced similar changes in the biomass of oysters and reef-resident fish (Figures 8 and 9). The time for oysters to reach a maximum biomass was reduced by about 1 year compared to the baseline model when increasing the growth rate by 50% (Figure 8a). Changes from a 50% increase in oyster growth rate were most evident during the fall of year 1 when oyster biomass and reef-resident fish biomass were 190% and 80% higher, respectively, than the baseline model, and during the fall of year 2 when oyster and reef-resident fish biomass were

both 100% higher than the baseline model (Figure 8a-b). After 5 years a 50% growth rate increase produced an overall increase of 15% in oyster and reef-resident fish biomass. A doubling (+100%) of the oyster growth rate reduced the time for oysters to reach their maximum biomass values by 1.5 years, and produced a 20% increase in the biomass of oysters and reef-resident fish after 5 years (Figure 8a-b).

Increases in the oyster growth rate led to proportionally larger magnitude impacts on transient non-piscivorous fish biomass than on transient piscivorous fish (Figure 8c-d). In comparison to the baseline model, a 50% increase in oyster growth rate produced a 50% increase in biomass of transient non-piscivorous fish biomass during the fall of year 1, but had a negligible impact on transient piscivorous fish (+4%). During the fall of year 2, transient non-piscivorous fish biomass was 75% higher and transient piscivorous fish biomass was 20% higher than the baseline model. Although this percentage biomass changes are high, percentage changes are lower than those observed for the prey items of transient fish groups, oysters (100-190%) and reef-resident fish (80-100%), during the same time period. After 5 years, a 50% increase in the oyster growth rate produced a 15% increase in transient non-piscivorous fish biomass and an 8% increase in transient piscivorous fish biomass. A doubling of the oyster growth rate produced a 20% increase in transient non-piscivorous fish biomass and a 10% increase in transient piscivorous biomass after 5 years (Figure 8c-d).

The magnitude of biomass decreases produced from a 50% decrease in oyster growth rate were larger than those produced from a 50% increase in oyster growth rate (Figures 8 and 9). Oyster maximum biomass values were achieved 1.5 years later than the baseline model with a 50% decrease in oyster growth rate, compared to 1 year

earlier with a 50% increase in oyster growth rate. After 5 years, a 50% decrease in oyster growth rate produced a 40% decline in biomass of oysters, reef-resident fish, and transient non-piscivorous fish (Figure 9a-c), compared to the 15% biomass increase of these functional groups produced by a 50% oyster growth rate increase. After 5 years, a 50% decrease in oyster growth rate produced a 25% decline in biomass of transient piscivorous fish, compared to an 8% increase produced by a 50% oyster growth rate increase (Figure 9d).

### *Scenario 3: Changes to Dependence on Oyster Reef Derived Prey*

Increasing the dependence of transient non-piscivorous fish on oyster-reef derived prey (Diet 1) led to a decrease in biomass of this transient group during years 1-2, followed by a biomass increase during years 3-5 (Figure 10). During the first 1.5 years, biomass for oysters was approximately 20% lower, biomass for transient non-piscivorous fish was approximately 30% lower, and effects on transient piscivorous fish were negligible (-2%) (Figure 10c-d). Despite the increased preference for oyster-reef derived prey by transient non-piscivorous fish; the amount of available prey biomass cannot sustain the high biomass levels of transient non-piscivorous during the first year and a half, compared to the baseline model. This biomass decrease during the first year could indicate that a higher dependence on outside carbon allows the transient non-piscivorous group to have higher biomass levels while biomass of oyster-reef derived prey reaches biomass levels that can sustain transient non-piscivorous fish. Oysters and on-reef invertebrates reach their maximum biomass values after 3 years, when transient non-piscivorous fish biomass is higher than values predicted by the baseline

model. After 5 years, oyster and on-reef invertebrate biomass decreased approximately 25%, while biomass of transient non-piscivorous fish increased 15% and transient piscivorous fish remained largely unaffected (- 4-6%). Increased predation on oyster-reef derived prey by transient non-piscivorous fish produced a biomass increase in this fish group, but only once biomass of its prey source reached their maximum value during year 3. Biomass of reef-resident fish biomass (Figure 10b) declined due to prey limitation since transient non-piscivorous fish consumed a larger proportion of on-reef invertebrates, the main prey source for reef-resident fish.

Increasing the dependence of both transient fish groups on oyster reef-derived prey (Diet 2) produced an overall decrease in biomass of both transient groups during all 5 years (Figure 10). Predicted oyster biomass values produced from Diet 2 were higher than values predicted under Diet 1 and similar to oyster biomass predicted by the baseline model (Figure 10a). During years 1-3, the Diet 2 change produced the lowest predicted biomass values for transient non-piscivorous fish, 20-50% lower than baseline predicted values (Figure 10c). The decline in predicted biomass for transient non-piscivorous fish could release oysters from predation and explain the increase in oyster biomass, relative to the Diet 1. After five years, biomass of transient non-piscivorous fish was similar to the baseline mode (5% decline), but compared to Diet 1 this represented a 15-20% decrease in biomass (Figure 10d). Due to the increase in oyster reef derived prey after 5 years we expected an increase in the biomass of transient non-piscivorous fish, but predation by transient piscivorous fish limited their biomass. After 5 years biomass of transient piscivorous fish was 15% lower than the baseline model, compared to a reduction of 5% from the baseline model under Diet 1. Predicted reef-



resident fish biomass changes from Diet 2 were similar to changes produced from Diet 1 (Figure 10b), as the increased predation by transient piscivorous fish was offset by an increase in on-reef invertebrates.

Diet 2 produced an overall decrease in transient fish biomass compared to the baseline model. Increasing the dependence of transient non-piscivorous fish on oyster reef derived prey from 50% to 80% and for transient piscivorous fish from 45% to 75% produces a situation in which the oyster reef system could not provide enough prey biomass to sustain the biomass of these transient groups. This would suggest that prey availability from outside sources may be crucial in sustaining the biomass of transient species.

## Discussion

Previous oyster models have been developed, but for the most part have focused on understanding oyster population dynamics and the impact of oyster filtration on basin wide water quality (Ulanowicz and Tuttle 1992, Cerco and Noel 2005, Wang et al. 2008, Powell et al. 2009b, Fulford et al. 2010). These models provide a framework to link oyster reef restoration to specific goals, be it developing harvesting limits or improving water quality; however, few models have incorporated the effects of oyster restoration on higher trophic level groups. Fulford et al. (2010) found a negative effect on pelagic fish due to an increase in oyster biomass—a result of increased competition for resources. Transient benthic fish species increased after an increase in oyster biomass due to the linear increase in reef-resident fish and proportional increase of on-reef invertebrates, both prey items for transient fish (Fulford et al. 2010). While an increase in fish biomass is expected from increases in oyster biomass, Fulford et al. (2010)'s model could be an overestimation due to assumptions regarding the dependence of transient fish on oyster-reef derived prey and the linear relationship between reef-resident fish and oyster biomass. Ulanowicz and Tuttle (1992) found that decreases in oyster exploitation led to declines in phytoplankton and gelatinous zooplankton, accompanied by increases in pelagic and carnivorous fish production, representing an improvement in the state of the estuary.

Model projections were able to describe biomass growth patterns of oysters and fish functional groups in a restored oyster reef system in the northern Gulf of Mexico, based on available data. Oysters grow rapidly during the first years until reaching a carrying capacity, consistent with Powell et al. (2009b)'s description of oyster population growth.

On-reef invertebrates were described as a proportion of oyster biomass, since they are associated with oyster reefs food, shelter, and substrate (Tolley and Volety 2005) — all of which would increase as oyster biomass increases. Previous studies have found that oyster restoration enhances invertebrate biomass (Grabowski et al. 2005, Tolley and Volety 2005). Thus, the projections of on-reef invertebrate biomass increasing with oyster biomass are consistent with previous field studies. The use of a constant and linear oyster to on-reef invertebrate ratio may cause an overestimation of on-reef invertebrate biomass; however few, if any, studies have documented proportional changes in the entire invertebrate community with changes in oyster biomass. Reef-resident fish predicted biomass for years 3-5 was higher than field-observed values for the first 1.5 years, but no data is available for this time period (>1.5 years). Oyster restoration enhances biomass and densities of reef-resident fish through the increase in prey availability and habitat structure (Peterson et al. 2003, Grabowski et al. 2005, Tolley and Volety 2005, Rodney and Paynter 2006). While the model can simulate the increased prey availability for reef-resident fish species, an indirect enhancement as a result of oyster reef structure can be more difficult to represent in a bioenergetic model, which links functional groups through direct consumption. The model appropriately reflected biomass for transient fish functional groups.

### ***Model Scenarios***

#### *Oyster Carrying Capacity and Growth Rate*

Changes to the oyster carrying capacity were aimed at understanding how restoration strategies that impact mean oyster biomass may affect transient fish groups

associated with oyster reefs. A mean oyster density or biomass target is often used as a restoration goal to determine the success of restoration (Coen and Luckenbach 2000, Brumbaugh et al. 2006, Powers et al. 2009, Baggett et al. 2014). However, different environmental constraints and restoration techniques can impact the observed mean oyster biomass following a restoration project (Powell et al. 2009b, Schulte et al. 2009, Harwell et al. 2011, Soniat et al. 2012). Additionally, natural environmental variability and human-induced stress can result in changes to the carrying capacity of oyster populations (Powell et al. 2009b). My results show that increases to the oyster carrying capacity had predictable increases in the biomass all functional groups. Functional groups that were directly linked to oysters through consumption of oysters or on-reef invertebrates had percentage increases nearly equal to the oyster carrying capacity percentage increase. These changes were most evident in year 3. This simulation may have limited applications for restoration managers since predicting the mean biomass that will result from a restored oyster reef may be challenging due to the different factors that impact mean oyster biomass (Powell et al. 2009b, Schulte et al. 2009, Harwell et al. 2011, Soniat et al. 2012). Nonetheless, these results provide evidence that increasing the mean biomass of oysters should also produce an increase in transient fish biomass due to the increase in prey biomass. Similarly, decreasing oyster biomass will produce proportional decreases in biomass of fish functional groups.

Changes to the oyster growth rate were aimed at understanding how a restoration strategy affecting this rate, most likely through placement in an area that could either favor or hinder oyster growth, would affect transient fish groups. Increasing the oyster growth rate produced an overall increase in the biomass of all functional groups at the

end of 5 years and decreased the amount of time required to reach stable biomass values. The largest increases in biomass were observed in the early years (years 1-2)—despite maintaining the same model imposed oyster carrying capacity of 600 gCm<sup>-2</sup>. During the first two years, oyster biomass experienced increases of >100% while transient non-piscivorous fish increased only by 50-75%. Mesopredators, such as mud crabs, can decrease survival, recruitment, and abundance of oysters as a result of direct consumption of juvenile oysters (Grabowski 2004, O'Connor et al. 2008). Field and mesocosm experiments have shown that removal of mesopredators releases juvenile oysters from predation and increases survival, abundance, and recruitment of oysters (Grabowski 2004, O'Connor et al. 2008). While the model does not incorporate invertebrate mesopredators, predation by transient non-piscivorous fish simulates a comparable predation pressure. Model projections indicate that an increase in oyster growth rate allows for the early accumulation of oyster biomass, and in combination with the lower predation pressure during early years, this results in higher biomass values. After five years, an increase in prey biomass (oyster and on-reef invertebrates) produced higher biomass of fish functional groups. However, the oyster growth rate simulation also revealed that while an increase in oyster growth rate can have a beneficial impact, a decrease in oyster growth rate had disproportionately more detrimental impacts to the entire oyster reef community. This indicates that while an oyster growth rate produced slightly higher biomass of fishes an oyster growth rate decrease of a similar magnitude caused much larger fish biomass losses.

Restoration projects often have restoration goals to achieve a certain mean oyster biomass (Coen and Luckenbach 2000, Brumbaugh et al. 2006, Powers et al. 2009,

Baggett et al. 2014). But while it can be difficult to predict the oyster biomass that will result from the restoration project, selecting reef placement that favors oyster growth rates can be done using available environmental data and restoration tools (Cake 1983, Powell et al. 2009b, North et al. 2010, Pollack et al. 2012) and can have positive effects on both oysters and the associated fish community. Oyster growth rate may be enhanced by a variety of environmental conditions, particularly salinity, temperature, and dissolved oxygen (Kraeuter et al. 2007, Wang et al. 2008, Pollack et al. 2012). Water temperatures can affect juvenile oysters' growth rates; oysters in the warmer Gulf of Mexico have been found to have more rapid growth rates and also experience multiple spawning seasons, compared to the East Coast (Powell et al. 2009b, Soniat et al. 2012). Salinity can also impact growth rate, in Apalachicola Bay, FL oyster growth rate was found to have an optimal salinity range (17-26 ppt), and changes in river discharge leading to salinity changes outside the optimal range had negative impacts on growth (Wang et al. 2008). Casas et al. (2015) found that within the same site, salinity gradients caused significant changes in oyster reef growth rates. Population growth is also affected by recruitment rate, which must exceed a certain threshold for population growth to occur, but very high recruitment rates may increase density-dependent population mortality and reduce population size (Powell et al. 2009b, Knights and Walters 2010). Finally, anthropogenic factors such as disease spread may also negatively impact oyster growth rate and are influenced by environmental factors (high salinity increases prevalence of *Perkinsus marinus*) and oyster population dynamics (high oyster densities may accelerate disease spread) (Paynter and Burreson 1991, Chu et al. 1993, Powell et al. 2009b). Restoration managers can use available

environmental monitoring data prior to restoration projects to determine sites that will have conditions favoring optimal oyster and population growth rates (Soniati and Brody 1988, North et al. 2010). Habitat suitability indices can provide a valuable tool as they have been developed for oysters in multiple regions (Cake 1983, Soniat and Brody 1988, Pollack et al. 2012), and can be used to assess how various environmental conditions in different locations can collectively affect oyster growth. While previous models and studies have highlighted the importance of oyster growth rate, this model shows that the benefits of a favorable oyster growth rate will also produced benefits for the transient fish community leading to biomass increases of these fish.

#### *Dependence on Oyster Reef Derived Prey*

Increasing the dependence of transient fish functional groups on oyster reef derived prey produced increases in oyster biomass and limited the overall biomass of transient fish. Although there were two diet changes used, Diet 2 is more realistic as both transient species are heavily reliant on the reef (>50% consumption derived from the reef), rather than the Diet 1 for which only the transient non-piscivorous fish are heavily reliant on the reef while the transient piscivorous fish maintain a large portion of their consumption from an outside source. Increasing predation on transient non-piscivorous fish reduced their biomass and appears to have released oysters from predation, relative to Diet 1. Similar interactions among multiple trophic groups have been found in mesocosm and field experiments (Silliman and Bertness 2002, Grabowski 2004). Grabowski (2004) found that predation of mud crabs by oyster toadfish led to increased mud crab mortality and an increase in oyster abundance and survival. Silliman and

Bertness (2002) found that a recent decline in top predators (blue crabs and terrapins [*Malaclemys terrapin*]) has caused an increase in densities of marsh periwinkle *Littoraria irrorata* and massive losses of marsh substrate (Silliman and Bertness 2002). Model projections revealed a similar interaction, where predation by transient piscivorous fish controlled biomass of transient non-piscivorous fish and increased oyster biomass. However, increasing dependence of both transient fish groups on oyster reef derived prey produced an overall decline in combined transient fish biomass. This suggests that the amount of prey available on the oyster reef is not enough to support transient fish biomass levels produced by the baseline model, when transient fish obtained at least 50% of their nutrition from an outside source. Transient fish species consume prey items from different sources in estuaries (Polis et al. 1997, Heck et al. 2008, Yeager and Layman 2011, Quan et al. 2012), and the model suggests that connectivity among different habitats and ability of transient fish to obtain prey from other systems can be crucial in supporting transient fish biomass.

Previous work has shown that the existence of structured and nursery habitats near oyster restoration sites can have an impact on fish biomass following restoration (Grabowski et al. 2005). In Alabama, Geraldi et al. (2009) found no clear enhancement of total fish abundance or biomass as a result of a restored oyster reef, which was attributed to the presence of a dense salt marsh surrounding the restoration site. Grabowski et al. (2005) found that restored oyster reefs increased prey abundance regardless of placement, but transient fish abundance was significantly increased only when reefs were located in mud flats away from salt marshes and seagrass beds. The model presented here assumed that transient fish species foraged in surrounding



habitats by setting at least 50% of transient consumption to an outside carbon source. Increasing the dependence of transient groups on oyster reef derived prey revealed that the system could not sustain such high biomass levels as the baseline model. This suggests that while an oyster reef restored away from other habitat could support a transient fish community that was previously not there, or prey limited, the overall biomass of the transient community would be lower than if they were able to forage and obtain prey from other sources in addition to the reef. Although an oyster reef restored in an area where foraging grounds are limiting may result in a significant secondary production enhancement from pre-restoration levels, the model indicates that the ability of fish to forage in an outside system may be able to support higher levels of secondary production than when transient fish are limited to the reef. Restoration projects focusing on enhancing fish production should focus not only on location of the oyster reef in prey-limited areas, but also on maintaining connectivity among habitats with the goal of enhancing the basin-wide biomass of transient species.

## **Conclusions**

The model presented was able to mimic the dynamics of a particular restored oyster reef system in the northern Gulf of Mexico, and demonstrates that a complex model can be adapted to further understand how transient and resident species are linked to an oyster reef and how they respond to restoration alternatives. As the number of restoration projects and the amount of money used towards these projects continues to increase (Zu Ermgassen et al. 2012), population models describing the oyster reef community could be employed to set realistic and attainable goals for enhancement of

fish production. Peterson et al. (2003) developed one of the first quantitative studies to quantify fish and mobile crustacean enhancement from restored oyster reefs, this model is not a predictive tool and is based on restored reefs in the southeastern U.S. Moving forward, the development of models along with restoration projects could help managers and decision-makers set goals for restoration, and improve projects with the goal of enhancing fish production.

This model was developed to answer questions about restoration scenarios and model projections highlight the need for restoration strategies that focus on site selection for optimum oyster growth and connections among estuarine habitats. Optimizing oyster growth can decrease the time for the community to develop and reach stability and produce an overall higher biomass of both oysters and transient fish groups compared to sites that may not be optimal for oyster growth. Restoring oyster reefs in proximity to other estuarine habitats can lead to increases in transient fish biomass. While previous work has shown that restoration projects located near other estuarine habitats may result in functional redundancy, this model suggest that an oyster reef system may have limited abilities to maintain transient fish species biomass when these transient groups are mostly dependent on the oyster reef for prey biomass. Oyster reef restoration managers that aim to increase biomass of transient species should focus on site locations that are favorable for the growth of oyster, as well as maintaining connectivity among different estuarine habitats.

## Literature Cited

- Baggett L, Powers SP, Brumbaugh RD, Coen LD, DeAngelis B, Greene J, Hancock B, Morlock S. 2014. Oyster Habitat Restoration Monitoring and Assessment Handbook. The Nature Conservancy Arlington, VA, USA., 96pp.
- Barbier EB, Hacker SD, Kennedy C, Koch EW, Stier AC, Silliman BR. 2011. The value of estuarine and coastal ecosystem services. *Ecological Monographs* 81: 169-193.
- Bartell SM, Lefebvre G, Kaminski G, Carreau M, Campbell KR. 1999. An ecosystem model for assessing ecological risks in Quebec rivers, lakes, and reservoirs. *Ecological Modelling* 124: 43-67.
- Beck MW, et al. 2001. The Identification, Conservation, and Management of Estuarine and Marine Nurseries for Fish and Invertebrates. *BioScience* 51: 633-641.
- Beck MW, et al. 2011. Oyster Reefs at Risk and Recommendations for Conservation, Restoration, and Management. *BioScience* 61: 107-116.
- Brown KM, George GJ, Peterson GW, Thompson BA, Cowan Jr JH. 2008. Oyster predation by black drum varies spatially and seasonally. *Estuaries and Coasts* 31: 597-604.
- Brumbaugh RD, Coen LD. 2009. Contemporary approaches for small-scale oyster reef restoration to address substrate versus recruitment limitation: a review and comments relevant for the Olympia oyster, *Ostrea lurida* Carpenter 1864. *Journal of Shellfish Research* 28: 147-161.
- Brumbaugh RD, Beck MW, Coen LD, Craig L, Hicks P. 2006. A Practitioner's guide to the design and monitoring of shellfish restoration projects: an ecosystem services approach. Arlington, VA: The Nature Conservancy. Report no. MRD Educational Report No. 22.
- Bulleri F, Chapman MG. 2010. The introduction of coastal infrastructure as a driver of change in marine environments. *Journal of Applied Ecology* 47: 26-35.
- Cake EWJ. 1983. Habitat suitability index models: Gulf of Mexico American oyster. US Fish and Wildlife Service. Report no. FWS/OBS-82/10.57.
- Casas SM, La Peyre J, La Peyre MK. 2015. Restoration of oyster reefs in an estuarine lake: population dynamics and shell accretion. *Marine Ecology Progress Series* 524: 171-184.
- Cerco CF, Noel MR. 2005. Evaluating Ecosystem Effects of Oyster Restoration in Chesapeake Bay. . A Report to the Maryland Department of Natural Resources US Army Engineer Research and Development Center, Vicksburg MS.
- Chapman M, Underwood A. 2011. Evaluation of ecological engineering of "armoured" shorelines to improve their value as habitat. *Journal of Experimental Marine Biology and Ecology* 400: 302-313.

- Chu F-LE, La Peyre JF, Burreson CS. 1993. Perkinsus marinus infection and potential defense-related activities in eastern oysters, Crassostrea virginica: salinity effects. *Journal of Invertebrate Pathology* 62: 226-232.
- Coen LD, Luckenbach MW. 2000. Developing success criteria and goals for evaluating oyster reef restoration: ecological function or resource exploitation? *Ecological Engineering* 15: 323-343.
- Costanza, R., d'Arge, R., de Groot, R., Farber, S., Grasso, M., Hanon, B., Limburg, K., Naeem, S., O'Neill, R., Paruelo, J., Rasking, R., Sutton, P., Van den Belt, M. 1997. The value of the world's ecosystem services and natural capital. *Nature* 387: 235-260.
- Deegan LA, Johnson DS, Warren RS, Peterson BJ, Fleeger JW, Fagherazzi S, Wollheim WM. 2012. Coastal eutrophication as a driver of salt marsh loss. *Nature* 490: 388-392.
- Eggleston DB. 1990. Foraging behavior of the blue crab, Callinectes sapidus, on juvenile oysters, Crassostrea virginica: effects of prey density and size. *Bulletin of Marine Science* 46: 62-82.
- EPA US. 2000. Chesapeake 2000 Bay Agreement in Program USECB, ed. Annapolis, Maryland, USA.
- Fulford RS, Breitburg DL, Luckenbach M, Newell RI. 2010. Evaluating ecosystem response to oyster restoration and nutrient load reduction with a multispecies bioenergetics model. *Ecological Applications* 20: 915-934.
- Geraldi NR, Powers SP, Heck KL, Cebrian J. 2009. Can habitat restoration be redundant? Response of mobile fishes and crustaceans to oyster reef restoration in marsh tidal creeks. *Marine Ecology Progress Series* 389: 171-180.
- Grabowski JH. 2004. Habitat complexity disrupts predator-prey interactions but not the trophic cascade on oyster reefs. *Ecology* 85: 995-1004.
- Grabowski JH, Peterson CH. 2007. Restoring oyster reefs to recover ecosystem services. *Theoretical ecology series* 4: 281-298.
- Grabowski JH, Hughes AR, Kimbro DL, Dolan MA. 2005. How habitat setting influences restored oyster reef communities. *Ecology* 86: 1926-1935.
- Grabowski JH, Brumbaugh RD, Conrad RF, Keeler AG, Opaluch JJ, Peterson CH, Piehler MF, Powers SP, Smyth AR. 2012. Economic valuation of ecosystem services provided by oyster reefs. *BioScience* 62: 900-909.
- Grizzle RE, Coen LD. 2013. Slow Down and Reach Out (and We'll Be There): A Response to "Shellfish as Living Infrastructure" by Kate Orff. *Ecological Restoration* 31: 325-329.
- Halpern BS, Walbridge S, Selkoe KA, Kappel CV, Micheli F, D'Agrosa C, Bruno JF, Casey KS, Ebert C, Fox HE. 2008. A global map of human impact on marine ecosystems. *Science* 319: 948-952.

- Hamby D. 1994. A review of techniques for parameter sensitivity analysis of environmental models. *Environmental monitoring and assessment* 32: 135-154.
- Hanson P, Johnson T, Schindler D, Kitchell J. 1997. *Fish Bioenergetics 3.0 for Windows*. University of Wisconsin System Sea Grant Technical Report No WISCU-T-97-001.
- Harwell HD, Posey MH, Alphin TD. 2011. Landscape aspects of oyster reefs: effects of fragmentation on habitat utilization. *Journal of Experimental Marine Biology and Ecology* 409: 30-41.
- Heck KL, Thoman TA. 1984. The nursery role of seagrass meadows in the upper and lower reaches of the Chesapeake Bay. *Estuaries* 7: 70-92.
- Heck KL, Carruthers TJ, Duarte CM, Hughes AR, Kendrick G, Orth RJ, Williams SW. 2008. Trophic transfers from seagrass meadows subsidize diverse marine and terrestrial consumers. *Ecosystems* 11: 1198-1210.
- Hettler Jr WF. 1989. Food habits of juveniles of spotted seatrout and gray snapper in western Florida Bay. *Bulletin of Marine Science* 44: 155-162.
- Hobbs RJ. 2007. Setting effective and realistic restoration goals: key directions for research. *Restoration Ecology* 15: 354-357.
- James-Pirri M, Raposa K, Catena J. 2001. Diet composition of mummichogs, *Fundulus heteroclitus*, from restoring and unrestricted regions of a New England (USA) salt marsh. *Estuarine, Coastal and Shelf Science* 53: 205-213.
- Kells V, Carpenter K. 2011. *A Field Guide to Coastal Fishes From Maine to Texas*. The John Hopkins University Press.
- Kim CK, Park K, Powers SP. 2013. Establishing restoration strategy of eastern oyster via a coupled biophysical transport model. *Restoration Ecology* 21: 353-362.
- Kirby MX. 2004. Fishing down the coast: Historical expansion and collapse of oyster fisheries along continental margins. *Proceedings of the National Academy of Sciences of the United States of America* 101: 13096-13099.
- Knights AM, Walters K. 2010. Recruit-recruit interactions, density-dependent processes and population persistence in the eastern oyster *Crassostrea virginica*. *Mar Ecol Prog Ser* 404: 79-90.
- Kraeuter JN, Ford S, Cummings M. 2007. Oyster growth analysis: a comparison of methods. *Journal of Shellfish Research* 26: 479-491.
- La Peyre MK, Humphries AT, Casas SM, La Peyre JF. 2014. Temporal variation in development of ecosystem services from oyster reef restoration. *Ecological Engineering* 63: 34-44.
- Lehnert RL, Allen DM. 2002. Nekton use of subtidal oyster shell habitat in a southeastern US estuary. *Estuaries* 25: 1015-1024.

- Lenihan HS, Peterson CH, Byers JE, Grabowski JH, Thayer GW, Colby DR. 2001. Cascading of habitat degradation: oyster reefs invaded by refugee fishes escaping stress. *Ecological Applications* 11: 764-782.
- Lindahl O, Hart R, Hernroth B, Kollberg S, Loo L-O, Olrog L, Rehnstam-Holm A-S, Svensson J, Svensson S, Syversen U. 2005. Improving marine water quality by mussel farming: a profitable solution for Swedish society. *AMBIO: A Journal of the Human Environment* 34: 131-138.
- Lipcius RN, Eggleston DB, Heck Jr KL, Seitz RD, van Montfrans J. 2007. Post-settlement abundance, survival, and growth of postlarvae and young juveniles in nursery habitats. Pages 535-564 in Kennedy VS, Cronin E, eds. *The Blue Crab: Callinectes sapidus*. College Park, MD: Maryland Sea Grant.
- Lotze HK, Lenihan HS, Bourque BJ, Bradbury RH, Cooke RG, Kay MC, Kidwell SM, Kirby MX, Peterson CH, Jackson JB. 2006. Depletion, degradation, and recovery potential of estuaries and coastal seas. *Science* 312: 1806-1809.
- Megrey BA, Rose KA, Klumb RA, Hay DE, Werner FE, Eslinger DL, Smith SL. 2007. A bioenergetics-based population dynamics model of Pacific herring (*Clupea harengus pallasii*) coupled to a lower trophic level nutrient-phytoplankton-zooplankton model: Description, calibration, and sensitivity analysis. *Ecological Modelling* 202: 144-164.
- Moberg F, Folke C. 1999. Ecological goods and services of coral reef ecosystems. *Ecological Economics* 29: 215-233.
- Naito W, Miyamoto K-i, Nakanishi J, Masunaga S, Bartell SM. 2002. Application of an ecosystem model for aquatic ecological risk assessment of chemicals for a Japanese lake. *Water Research* 36: 1-14.
- Nelson KA, Leonard LA, Posey MH, Alphin TD, Mallin MA. 2004. Using transplanted oyster (*Crassostrea virginica*) beds to improve water quality in small tidal creeks: a pilot study. *Journal of Experimental Marine Biology and Ecology* 298: 347-368.
- Newell RI, Kemp WM, Hagy J, Cerco CF, Testa JM, Boynton WR. 2007. Top-down control of phytoplankton by oysters in Chesapeake Bay, USA: Comment on Pomeroy et al.(2006). *Marine Ecology Progress Series* 341: 293.
- Nixon S, Oviatt C, Frithsen J, Sullivan B. 1986. Nutrients and the productivity of estuarine and coastal marine ecosystems. *Journal of the Limnological Society of Southern Africa* 12: 43-71.
- NOAA. 2014. Commercial Fisheries Statistics: Annual Commercial Landing Statistics. (November 2014; <http://www.st.nmfs.noaa.gov/commercial-fisheries/commercial-landings/annual-landings/index>)
- North E, King D, Xu J, Hood R, Newell R, Paynter K, Kellogg M, Liddel M, Boesch D. 2010. Linking optimization and ecological models in a decision support tool for oyster restoration and management. *Ecological Applications* 20: 851-866.

- O'Connor NE, Grabowski JH, Ladwig LM, Bruno JF. 2008. Simulated predator extinctions: predator identity affects survival and recruitment of oysters. *Ecology* 89: 428-438.
- Orth, R. J., Carruthers, T. J. B., Dennison, W. C., Duarte, C. M., Fourqurean, J. W., Heck, K. L., Hughes, R.A., Kendrick, G.A., Kenworthy, W.J., Olyarnik, S., Short, F.t., Wyacott, M., Williams, S. L. 2006. A Global Crisis for Seagrass Ecosystems. *BioScience* 56: 987-996.
- Paynter KT, Burreson E. 1991. Effects of *Perkinsus marinus* infection in the eastern oyster, *Crassostrea virginica*: II. Disease development and impact on growth rate at different salinities. *J. Shellfish Res* 10: 425-431.
- Peterson CH, Grabowski JH, Powers SP. 2003. Estimated enhancement of fish production resulting from restoring oyster reef habitat: quantitative valuation. *Marine Ecology Progress Series* 264: 249-264.
- Piazza BP, Banks PD, La Peyre MK. 2005. The potential for created oyster shell reefs as a sustainable shoreline protection strategy in Louisiana. *Restoration Ecology* 13: 499-506.
- Plunket J, La Peyre MK. 2005. Oyster beds as fish and macroinvertebrate habitat in Barataria Bay, Louisiana. *Bulletin of Marine Science* 77: 155-164.
- Polis GA, Anderson WB, Holt RD. 1997. Toward an integration of landscape and food web ecology: the dynamics of spatially subsidized food webs. *Annual review of ecology and systematics*: 289-316.
- Pollack JB, Cleveland A, Palmer TA, Reisinger AS, Montagna PA. 2012. A restoration suitability index model for the Eastern oyster (*Crassostrea virginica*) in the Mission-Aransas Estuary, TX, USA. *PLoS one* 7: e40839.
- Powell EN, Klinck JM, Ashton-Alcox KA, Kraeuter JN. 2009a. Multiple stable reference points in oyster populations: biological relationships for the eastern oyster (*Crassostrea virginica*) in Delaware Bay. *Fishery Bulletin* 107: 109-132.
- . 2009b. Multiple stable reference points in oyster populations: implications for reference point-based management. *Fishery Bulletin* 107: 133-147.
- Powers SP, Peterson CH, Grabowski JH, Lenihan HS. 2009. Success of constructed oyster reefs in no-harvest sanctuaries: implications for restoration. *Marine Ecology Progress Series* 389: 159-170.
- Quan W-m, Humphries AT, Shi L-y, Chen Y-q. 2012. Determination of trophic transfer at a created intertidal oyster (*Crassostrea ariakensis*) reef in the Yangtze River estuary using stable isotope analyses. *Estuaries and coasts* 35: 109-120.
- R Core Team. 2013. R: A language and environment for statistical computing. R Foundation for Statistical Computing, Vienna, Austria. URL <http://www.R-project.org/>
- Ricciardi A, Bourget E. 1998. Weight-to-weight conversion factors for marine benthic macroinvertebrates. *Marine Ecology Progress Series* 163: 245-251.

- Rice JA, Cochran PA. 1984. Independent evaluation of a bioenergetics model for largemouth bass. *Ecology*: 732-739.
- Rodney WS, Paynter KT. 2006. Comparisons of macrofaunal assemblages on restored and non-restored oyster reefs in mesohaline regions of Chesapeake Bay in Maryland. *Journal of Experimental Marine Biology and Ecology* 335: 39-51.
- Salonen K, Sarvala J, Hakala I, Viljanen ML. 1976. The relation of energy and organic carbon in aquatic invertebrates<sup>1</sup>. *Limnology and Oceanography* 21: 724-730.
- Scavia D, Field JC, Boesch DF, Buddemeier RW, Burkett V, Cayan DR, Fogarty M, Harwell MA, Howarth RW, Mason C. 2002. Climate change impacts on US coastal and marine ecosystems. *Estuaries* 25: 149-164.
- Schulte DM, Burke RP, Lipcius RN. 2009. Unprecedented restoration of a native oyster metapopulation. *Science* 325: 1124-1128.
- Shaeffer DL. 1980. A model evaluation methodology applicable to environmental assessment models. *Ecological Modelling* 8: 275-295.
- Silliman BR, Bertness MD. 2002. A trophic cascade regulates salt marsh primary production. *Proceedings of the national Academy of Sciences* 99: 10500-10505.
- . 2004. Shoreline development drives invasion of *Phragmites australis* and the loss of plant diversity on New England salt marshes. *Conservation Biology* 18: 1424-1434.
- Soetaert K, Petzoldt T. 2010. Inverse Modelling, Sensitivity and Monte Carlo Analysis in R Using Package FME. *Journal of Statistical Software* 33: 1-28.
- Soetaert K, Petzoldt T, Setzer RW. 2010. Solving differential equations in R: package deSolve. *Journal of Statistical Software* 33: 1-25.
- Soniat TM, Brody MS. 1988. Field validation of a habitat suitability index model for the American oyster. *Estuaries* 11: 87-95.
- Soniat TM, Klinck JM, Powell EN, Cooper N, Abdelguerfi M, Hofmann EE, Dahal J, Tu S, Finigan J, Eberline BS. 2012. A shell-neutral modeling approach yields sustainable oyster harvest estimates: a retrospective analysis of the Louisiana state primary seed grounds. *Journal of Shellfish Research* 31: 1103-1112.
- Tolley SG, Volety AK. 2005. The role of oysters in habitat use of oyster reefs by resident fishes and decapod crustaceans. *Journal of Shellfish Research* 24: 1007-1012.
- Tsoularis A, Wallace J. 2002. Analysis of logistic growth models. *Mathematical biosciences* 179: 21-55.
- Ulanowicz RE, Tuttle JH. 1992. The trophic consequences of oyster stock rehabilitation in Chesapeake Bay. *Estuaries* 15: 298-306.
- Wang H, Huang W, Harwell MA, Edmiston L, Johnson E, Hsieh P, Milla K, Christensen J, Stewart J, Liu X. 2008. Modeling oyster growth rate by coupling oyster population and hydrodynamic models for Apalachicola Bay, Florida, USA. *ecological modelling* 211: 77-89.



Wells HW. 1961. The fauna of oyster beds, with special reference to the salinity factor. *Ecological Monographs*: 239-266.

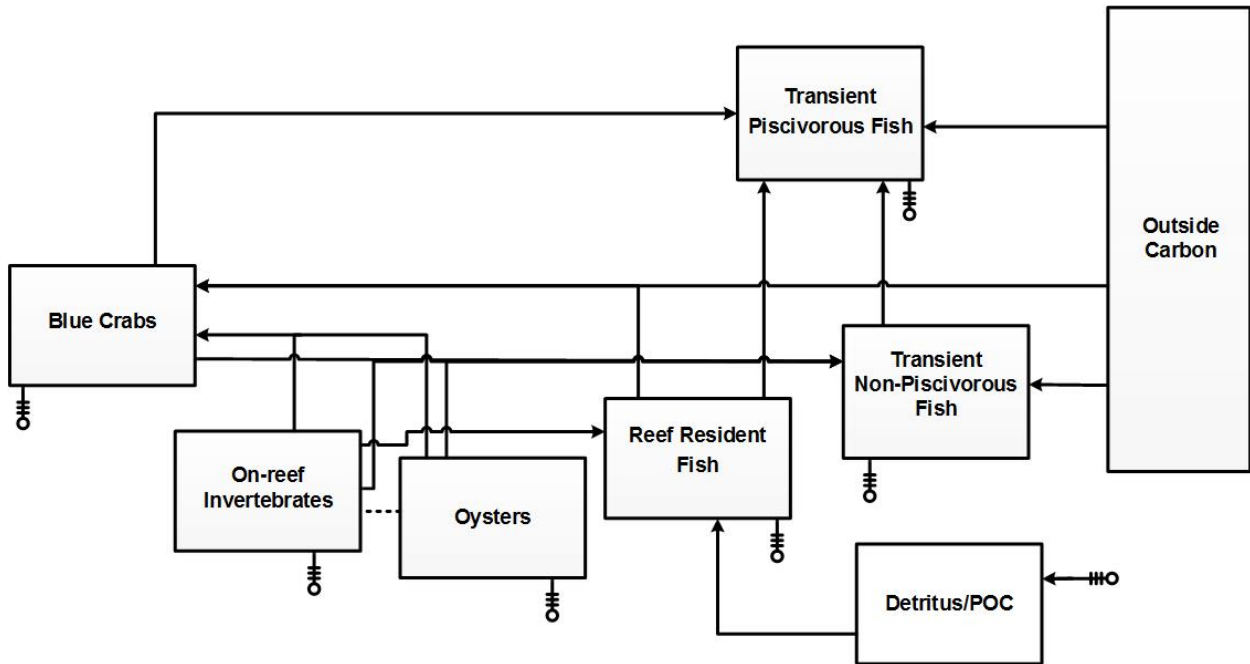
Winsor CP. 1932. The Gompertz curve as a growth curve. *Proceedings of the National Academy of Sciences of the United States of America* 18: 1.

Yeager LA, Layman CA. 2011. Energy flow to two abundant consumers in a subtropical oyster reef food web. *Aquatic Ecology* 45: 267-277.

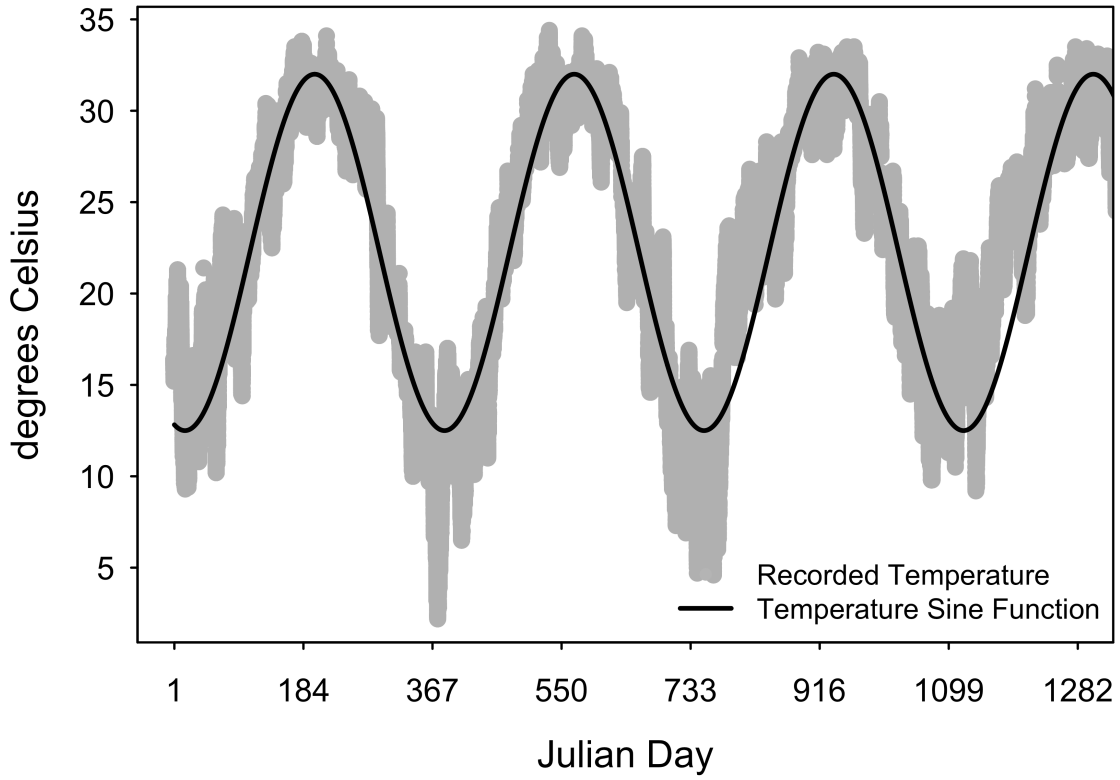
Zimmerman RJ, Minello TJ, T B, M C. 1989. Oyster reef as habitat for estuarine macrofauna. *NOAA Tech Memo NMFS-SEFC-249*: 16.

Zu Ermgassen PS, Spalding MD, Blake B, Coen LD, Dumbauld B, Geiger S, Grabowski JH, Grizzle R, Luckenbach M, McGraw K. 2012. Historical ecology with real numbers: past and present extent and biomass of an imperilled estuarine habitat. *Proceedings of the Royal Society of London B: Biological Sciences* 279: 3393-3400.

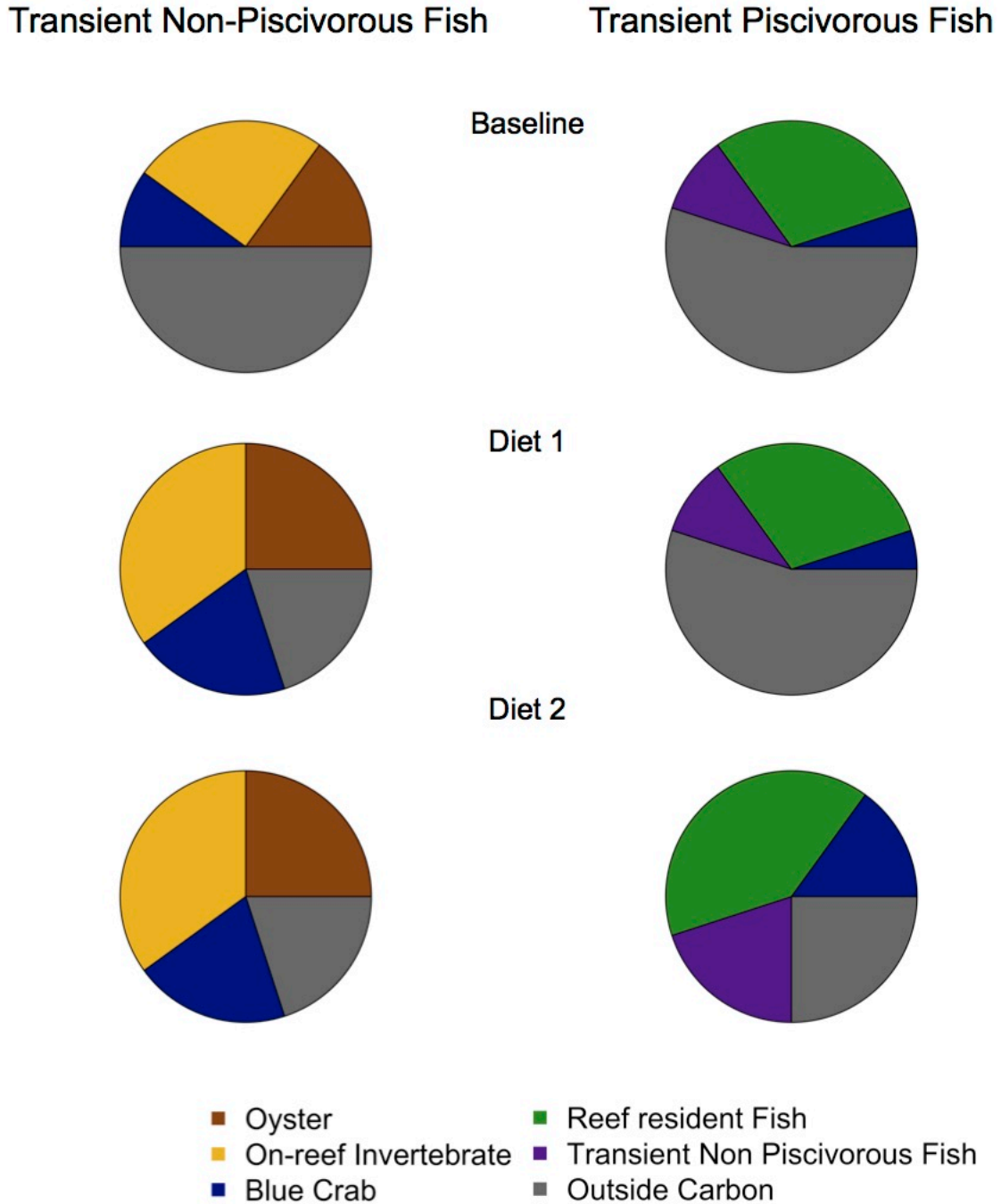
**Figure 1.** Model diagram describing the flow of carbon among functional groups in the oyster reef bioenergetics model. Boxes represent functional groups and arrows represent direct consumption, among functional groups. Dashed line between Oysters and On-reef Invertebrates proportional interaction between this two groups used to describe On-reef Invertebrates growth.



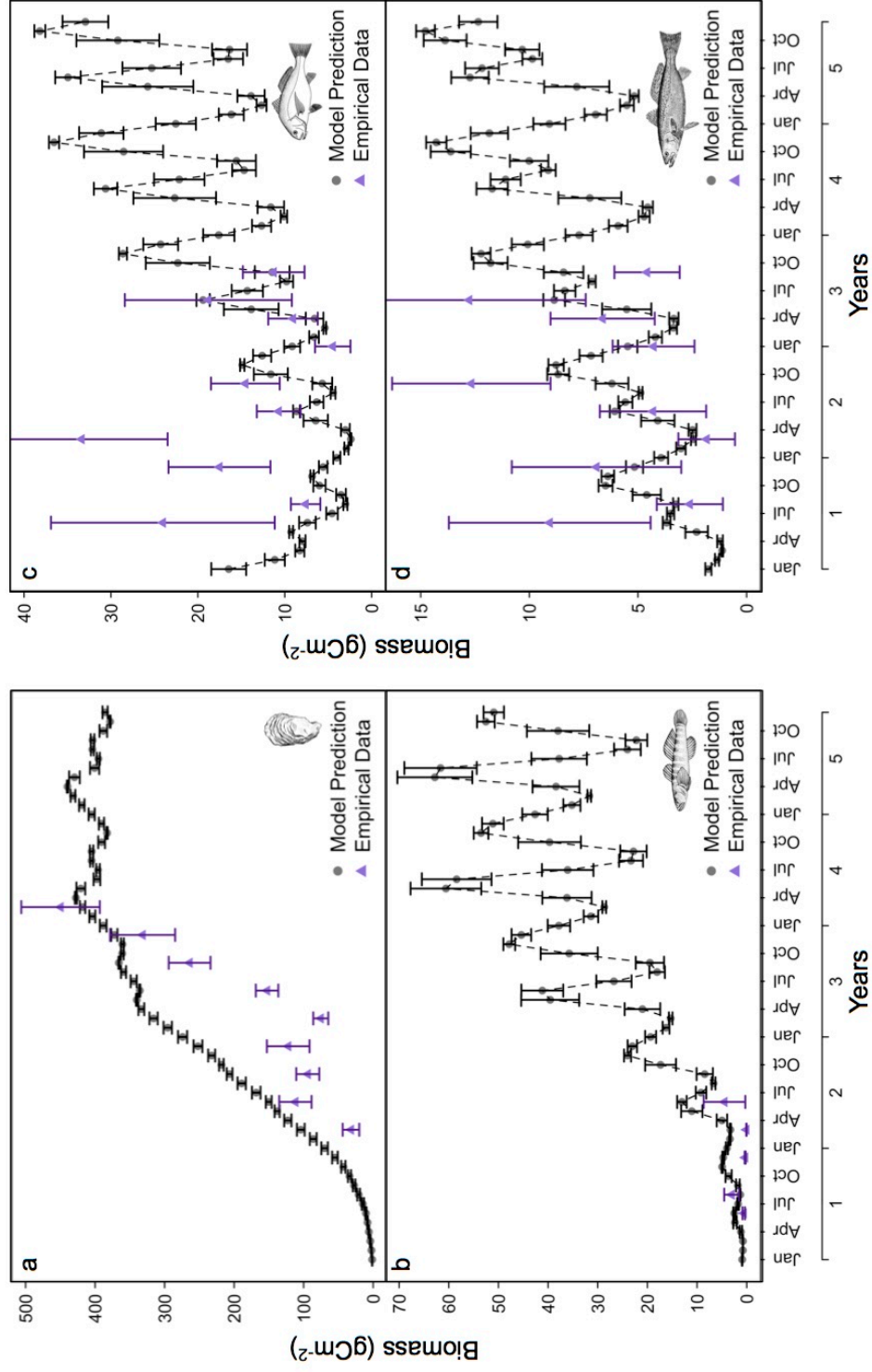
**Figure 2.** Continuous temperatures from USGS Station LDWF/USGS 07381349 at Sister Lake, LA, with overlaying sine function used as temperature forcing function in bioenergetics model



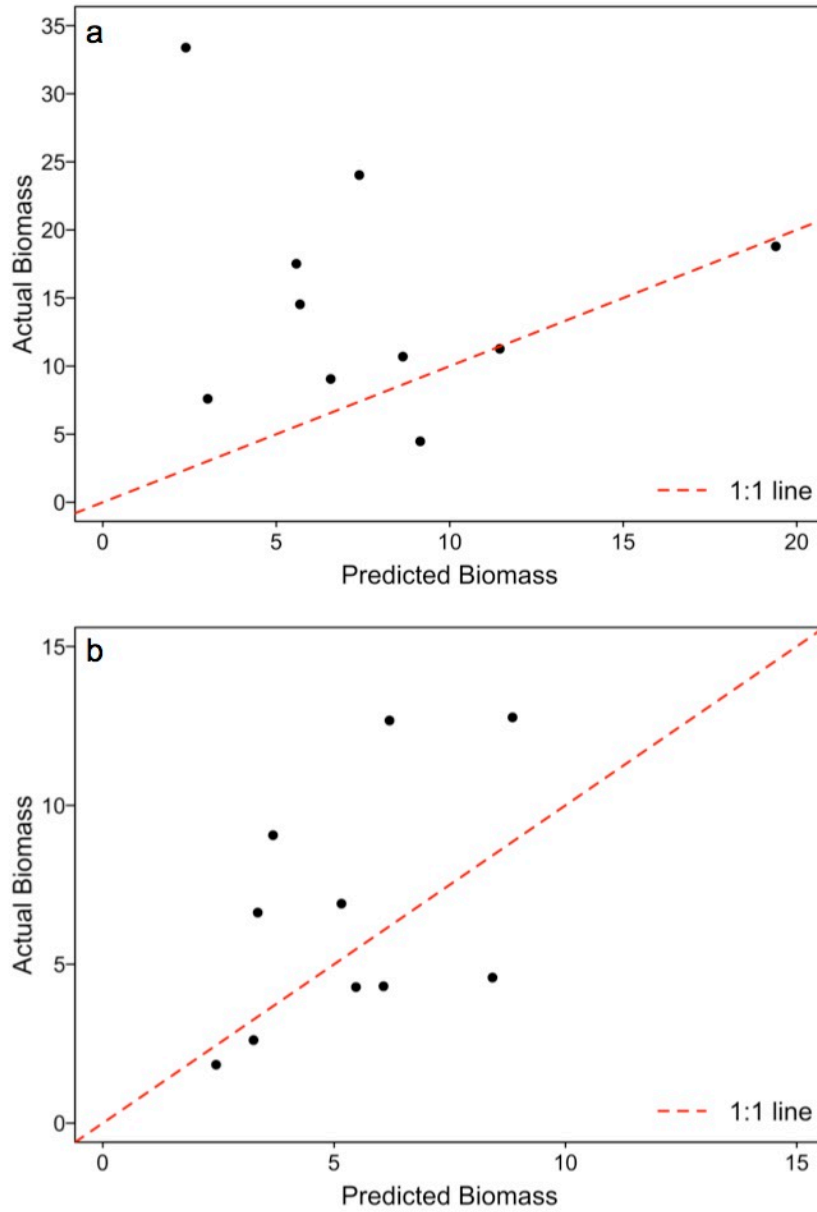
**Figure 3.** Diet percentage distribution for Transient Non-Piscivorous Fish and Transient Piscivorous fish used for the baseline model and *Simulation 3: Changes to Dependence on Oyster Reef Derived Prey*. Percentage parameters for baseline diet distribution can be found on Table 3.



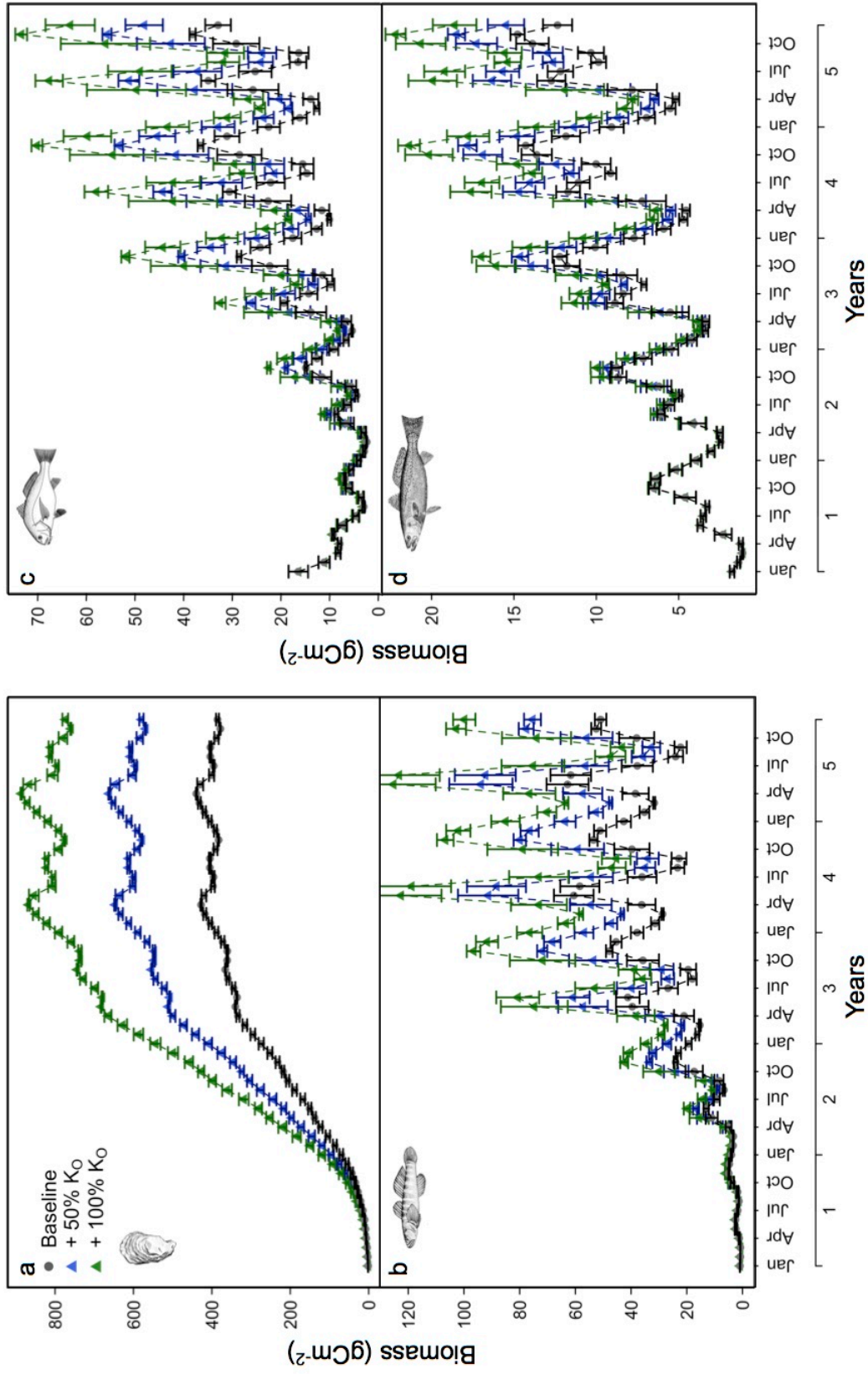
**Figure 4.** Monthly model predicted biomass for functional groups. Grey dots represent monthly averaged biomass purple triangles represent monthly biomass of functional groups obtained from the Louisiana restoration project. **a.** Oysters. **b.** Reef resident fish, such as blenny and gobies. **c.** Transient non-piscivorous fish, such as croaker, black drum, and stingray. **d.** Transient piscivorous fish such as perch, snapper, and seatrout. Bars represent standard error for monthly averages.



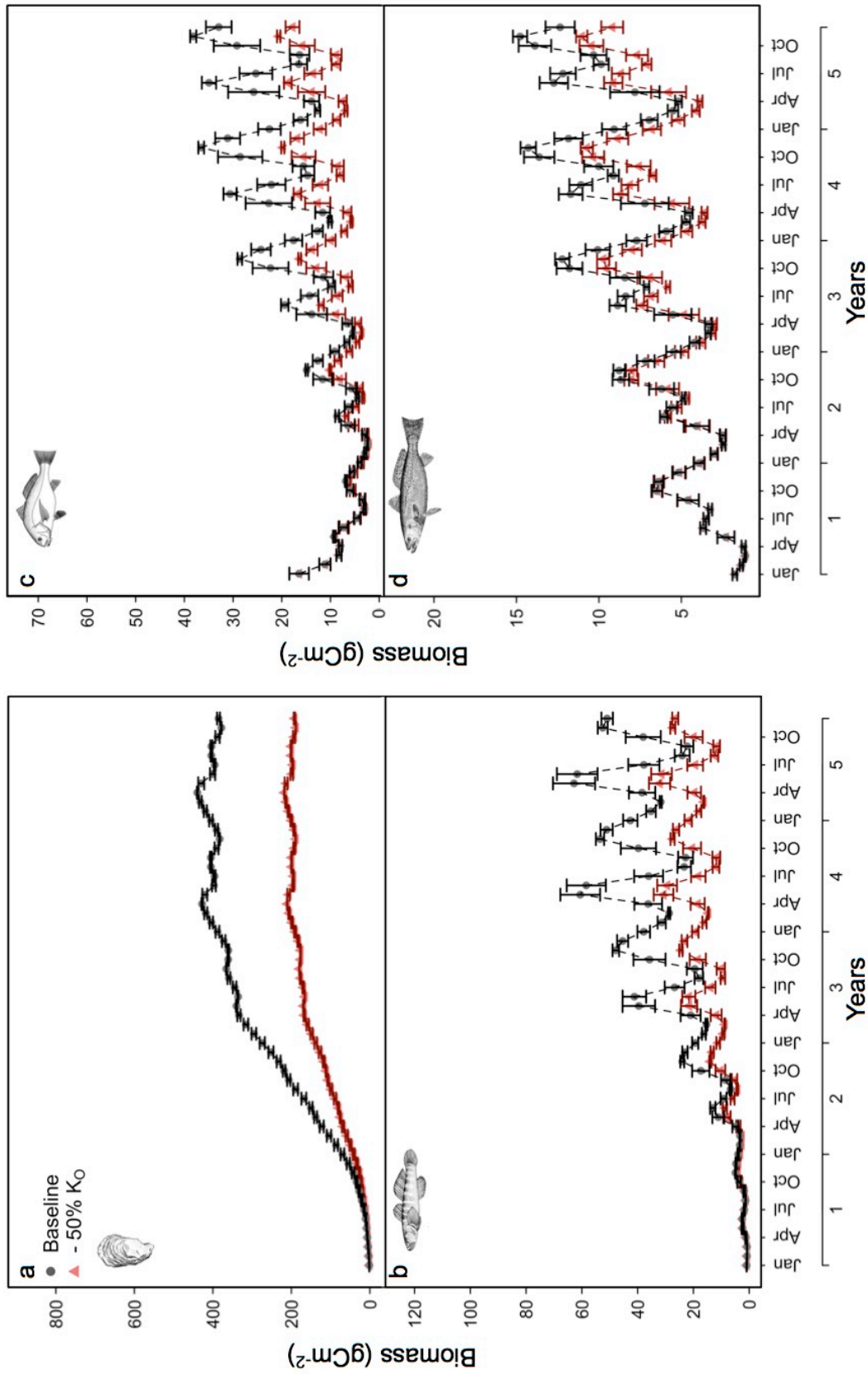
**Figure 5.** Monthly averaged model predicted biomass vs field-observed monthly averaged biomass for MSE analysis. **a.** Transient non-piscivorous fish. **b.** Transient piscivorous fish. Dashed red line is 1:1 line representing the line along which perfect model predictions would lie on compared to empirical data.



**Figure 6.** Monthly-averaged model predictions from Scenario 1 produced by increases to the oyster carrying capacity **a**. Oysters. **b**. Reef resident fish, such as blenny and gobies. **c**. Transient non-piscivorous fish, such as croaker, black drum, and stingray. **d**. Transient piscivorous fish such as perch, snapper, and seatrout. Bars represent standard error for monthly averages.

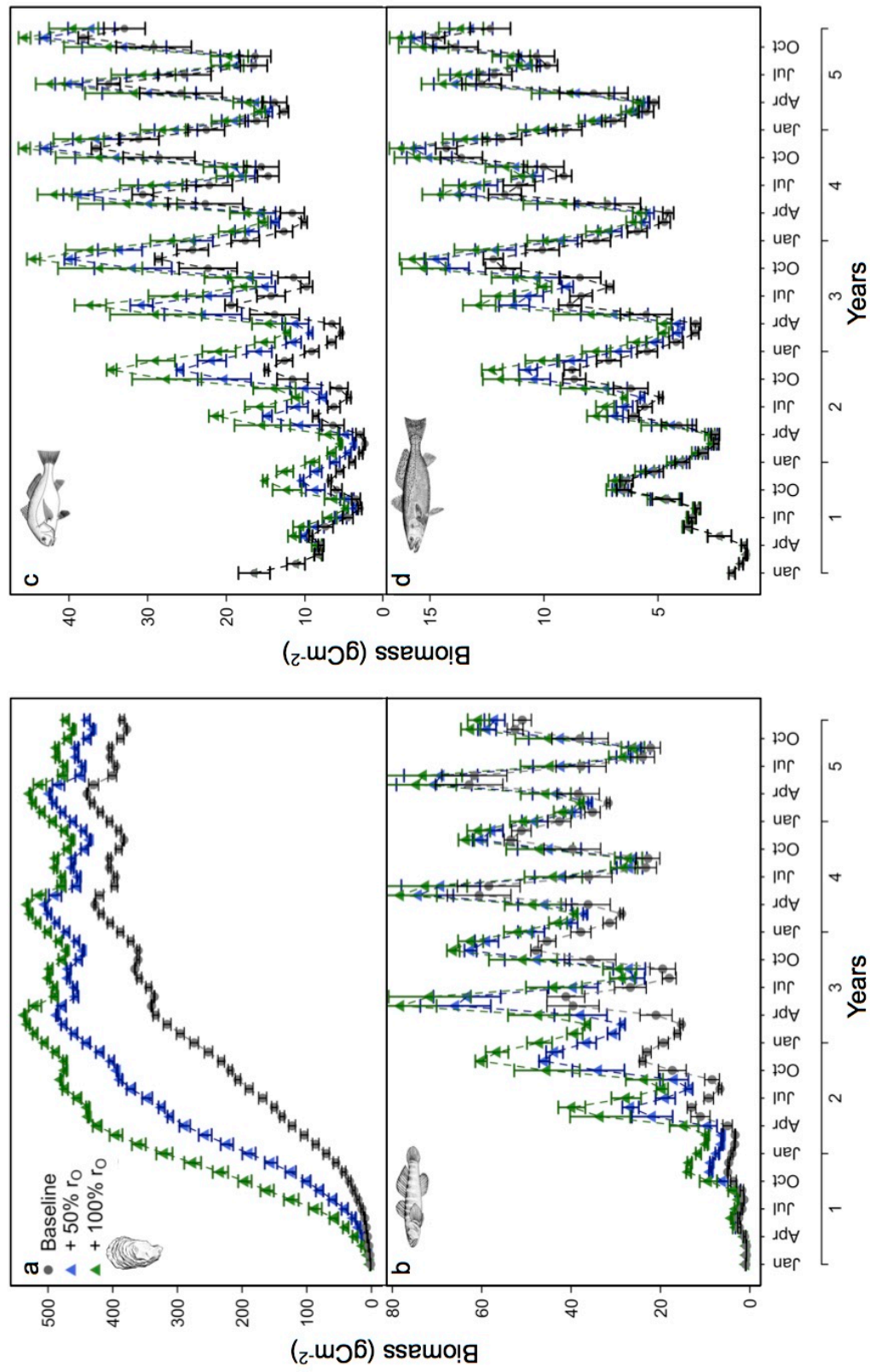


**Figure 7.** Monthly-averaged model predictions from Scenario 1 produced by a decrease to the oyster carrying capacity **a**. Oysters. **b.** Reef resident fish, such as blenny and gobies. **c.** Transient non-piscivorous fish, such as croaker, black drum, and stingray. **d.** Transient piscivorous fish such as perch, snapper, and seatrout. Bars represent standard error for monthly averages.

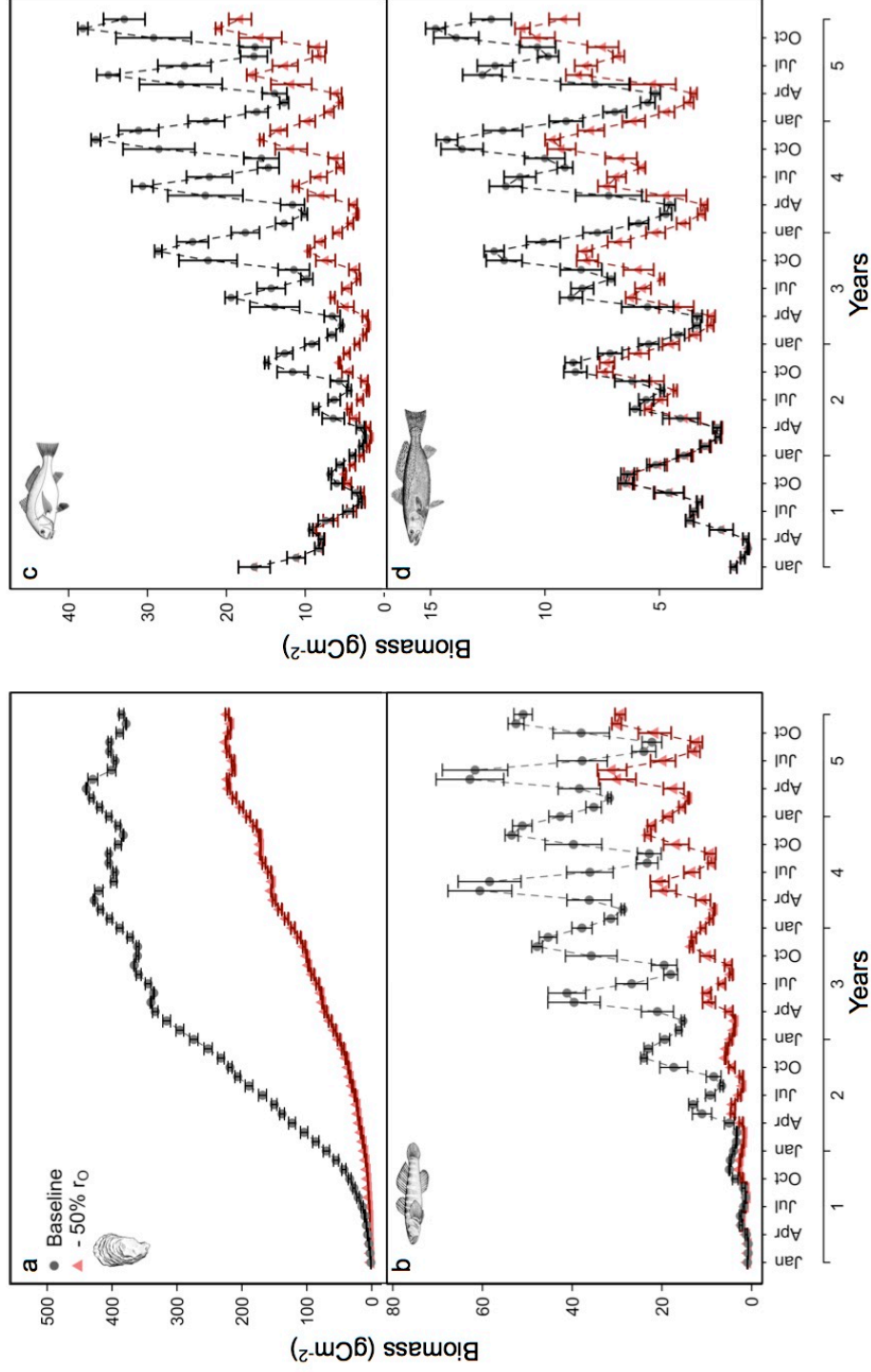




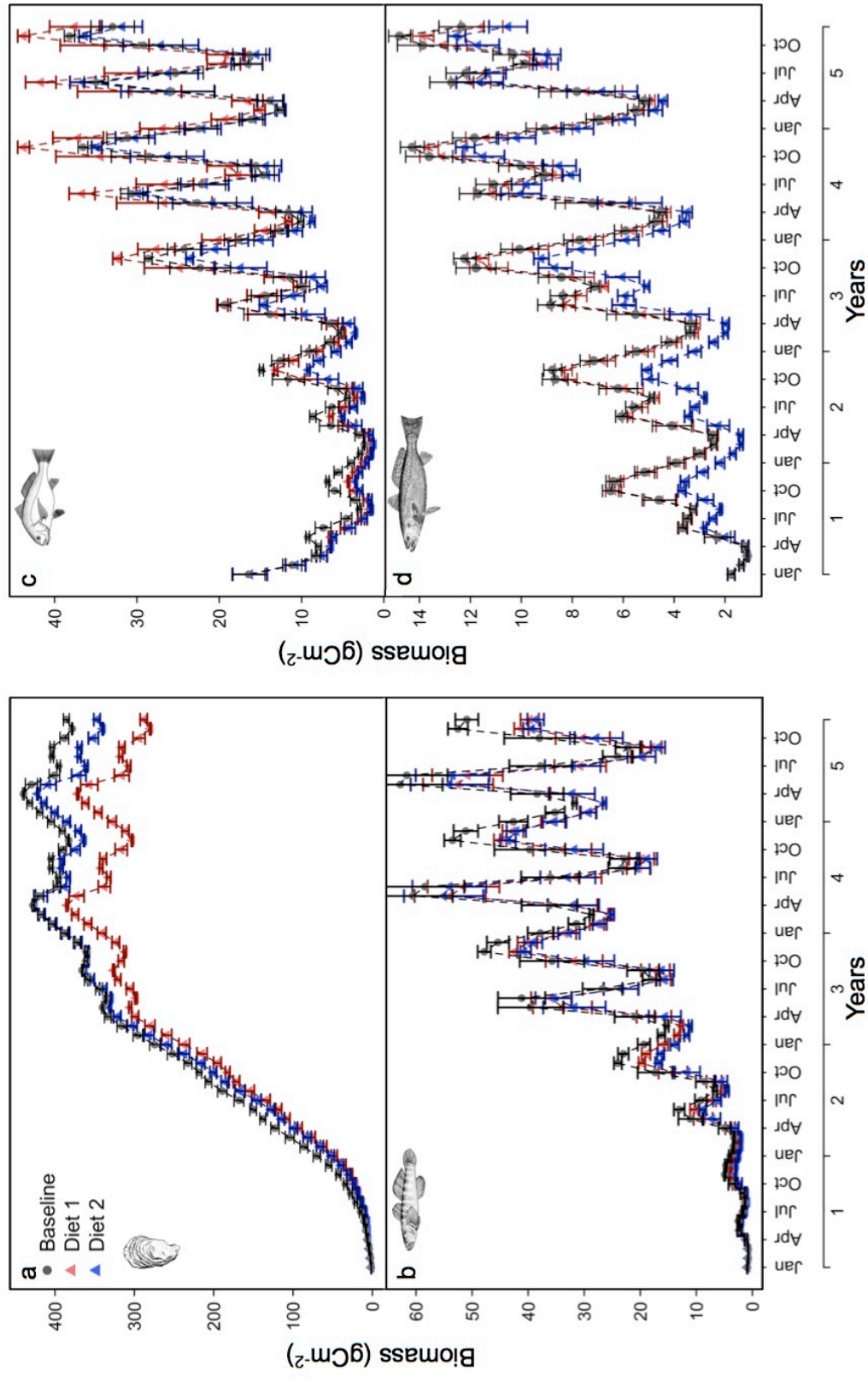
**Figure 8.** Monthly-averaged model predictions from Scenario 2 produced by increases to the oyster growth rate **a**. Oysters. **b.** Reef resident fish, such as blenny and gobies. **c.** Transient non-piscivorous fish, such as croaker, black drum, and stingray. **d.** Transient piscivorous fish such as perch, snapper, and seatrout. Bars represent standard error for monthly averages.



**Figure 9.** Monthly-averaged model predictions from Scenario 2 produced by a decrease to the oyster growth rate **a.** Oysters. **b.** Reef resident fish, such as blenny and gobies. **c.** Transient non-piscivorous fish, such as croaker, black drum, and stingray. **d.** Transient piscivorous fish such as perch, snapper, and seatrout. Bars represent standard error for monthly averages.



**Figure 10.** Monthly-averaged model predictions from Scenario 3 produced increasing the dependence of transient fish on oyster-reef derived prey **a**. Oysters. **b**. Reef resident fish, such as blenny and gobies. **c**. Transient non-piscivorous fish, such as croaker, black drum, and stingray. **d**. Transient piscivorous fish such as perch, snapper, and seatrout. Bars represent standard error for monthly averages.



**Table 1.** Fish species collected from restoration study, and assignment to appropriate functional group

<b>Scientific Name</b>	<b>Common Name</b>
Resident Fish	
<i>Chasmodes bosquianus</i>	Striped blenny
<i>Gobiellonus boleosoma</i>	Darter goby
<i>Gobiosoma bosc</i>	Naked goby
<i>Gobiesox strumosus</i>	Skilletfish
<i>Hypsoblennius hentz</i>	Blenny
<i>Hypsoblennius ionthas</i>	Freckled blenny
Transient Non-Piscivorous Fish	
<i>Ariopsis felis</i>	Hardhead catfish
<i>Archosargus probatocephalus</i>	Sheepshead
<i>Chaetodipterus faber</i>	Atlantic spadefish
<i>Dasyatis americana</i>	Southern stingray
<i>Leiostomus xanthurus</i>	Spot croaker
<i>Micropogonias undulatus</i>	Atlantic croaker
<i>Pogonias cromis</i>	Black drum
Transient Piscivorous Fish	
<i>Alosa chrysochloris</i>	Skipjack shad
<i>Bairdiella chrysoura</i>	Silver perch
<i>Bagre marinus</i>	Gafftopsail catfish
<i>Caranx hippos</i>	Crevelle jack
<i>Carcharhinus leucas</i>	Bull shark
<i>Cynoscion arenarius</i>	Sand seatrout
<i>Cynosicon nebulosus</i>	Spotted seatrout
<i>Elops saurus</i>	Ladyfish
<i>Lutjanus griseus</i>	Gray snapper
<i>Paralichthys lethostigma</i>	Southern flounder
<i>Sciaenops ocellatus</i>	Red drum
<i>Scomberomorus maculates</i>	Spanish mackerel
<i>Lagodon rhomboides</i>	Pinfish

**Table 2.** Functional group model parameters

Functional Group	Parameter								
Oysters	$B_0$ (gC m <sup>-2</sup> )	$r_{O_1}$ (gC gC <sup>-1</sup> d <sup>-1</sup> )	$K_O$ (gC m <sup>-2</sup> )						
	1 <sup>a</sup>	0.0035 <sub>a</sub>	600 <sup>a</sup>						
On-reef Invertebrates	$B_0$ (gC m <sup>-2</sup> )	$T_{max}$ (°C)	$T_{opt}$ (°C)	IO					
	1 <sup>a</sup>	40 <sup>b</sup>	30 <sup>b</sup>	0.5					
Blue Crabs	$B_0$ (gC m <sup>-2</sup> )	$C_{max}$ (gC gC <sup>-1</sup> d <sup>-1</sup> )	$R$ (gC gC <sup>-1</sup> d <sup>-1</sup> )	$E_{ff}$ <i>unitless</i>	Mort (d <sup>-1</sup> )	$M_{loss}$ (d <sup>-1</sup> )	$T_{max}$ (°C)	$T_{opt}$ (°C)	$T_{optR}$ (°C)
	0.03 <sup>a</sup>	0.08 <sup>c</sup>	0.020 <sub>c</sub>	0.45 <sup>d,</sup> <sub>c</sub>	0.010 <sub>d</sub>	0.020 <sub>d</sub>	39 <sup>c</sup>	31 <sup>c</sup>	34 <sup>c</sup>
	1 <sup>a</sup>	0.15 <sup>b</sup>	0.034 <sub>b</sub>	0.58 <sup>d</sup>	0.010 <sub>d</sub>	0.025 <sub>d</sub>	34 <sup>b</sup>	27 <sup>b</sup>	29 <sup>b</sup>
	20 <sup>a</sup>	0.13 <sup>b,d</sup>	0.030 <sub>b</sub>	0.60 <sup>d</sup>	0.015 <sub>d</sub>	0.030 <sub>d</sub>	34 <sup>b</sup>	27 <sup>e</sup>	29 <sup>f</sup>
Piscivorous Fish	2 <sup>a</sup>	0.11 <sup>f</sup>	0.030 <sub>b</sub>	0.70 <sup>d</sup>	0.010 <sub>d</sub>	0.025 <sub>d</sub>	34 <sup>b</sup>	28 <sup>f</sup>	29 <sup>f</sup>

<sup>a</sup> Unable to find parameter in literature, parameter determined based on Louisiana oyster restoration study; <sup>b</sup> Fulford et al. (2010); <sup>c</sup> Brylawski and Miller (2003); <sup>d</sup> Bartell et al. (1999); <sup>e</sup> Gillum et al. (2012); <sup>f</sup> Ault et al. (1999)

**Table 3.** Diet distribution input for model

<b>Functional Group</b>	<b>Preference</b>	<b>Prey/food Resource</b>
Blue Crabs	0.15	On-reef Inverts
	0.15	Oyster
	0.10	POC
	0.10	Resident Fish
	0.50	Outside Carbon Source
Resident Fish	0.40	POC
	0.60	On-reef Inverts
Transient Non-Piscivorous Fish	0.25	On-reef Inverts
	0.50	Outside Carbon Source
	0.15	Oyster
	0.10	Blue Crabs
	0.10	Transient Non-Piscivorous Fish
Transient Piscivorous Fish	0.10	Fish
	0.30	Resident Fish
	0.55	Outside Carbon Source
	0.05	Blue Crabs

**Table 4.** Ranked list of parameters for SI and RD Index sensitivities on biomass at day 1281 of transient non-piscivorous fish

Parameter	SI Index	Parameter	RD Index
T <sub>opt</sub> TNP	1.00	T <sub>opt</sub> TNP	1.10
T <sub>max</sub> TNP	1.00	T <sub>opt</sub> RTNP	0.98
E <sub>ff</sub> TNP	1.00	E <sub>ff</sub> TNP	0.95
C <sub>max</sub> TNP	1.00	C <sub>max</sub> TNP	0.88
MortTNP	1.00	MortTNP	0.82
T <sub>opt</sub> RTNP	1.00	R <sub>max</sub> TNP	0.78
R <sub>max</sub> TNP	1.00	T <sub>max</sub> TNP	0.65
VX	0.95	VX	0.54
r <sub>O</sub>	0.90	T <sub>max</sub> TP	0.45
K <sub>O</sub>	0.84	K <sub>O</sub>	0.42
T <sub>max</sub> TP	0.77	r <sub>O</sub>	0.42
C <sub>max</sub> TP	0.74	T <sub>opt</sub> TP	0.40
T <sub>opt</sub> TP	0.71	C <sub>max</sub> TP	0.32
C <sub>max</sub> BC	0.51	T <sub>opt</sub> RTP	0.24
T <sub>opt</sub> BC	0.50	T <sub>opt</sub> BC	0.23
IO	0.48	T <sub>opt</sub> ORI	0.23
w.TNP.ORI	0.47	IO	0.19
T <sub>max</sub> ORI	0.43	E <sub>ff</sub> TP	0.18
T <sub>opt</sub> ORI	0.43	w.TNP.ORI	0.17
T <sub>opt</sub> RTP	0.42	C <sub>max</sub> BC	0.17
E <sub>ff</sub> TP	0.40	MortTP	0.13
MortTP	0.35	R <sub>max</sub> TP	0.13
R <sub>max</sub> TP	0.35	w.TNP.O	0.10
E <sub>ff</sub> BC	0.31	E <sub>ff</sub> BC	0.10
w.TNP.O	0.31	T <sub>max</sub> ORI	0.09
w.TP.TNP	0.27	w.TP.TNP	0.09
M <sub>loss</sub> TNP	0.22	M <sub>loss</sub> TNP	0.07
MortBC	0.17	w.TNP.outC	0.04
w.TNP.outC	0.14	MortBC	0.04
K <sub>outC</sub>	0.11	K <sub>outC</sub>	0.03
T <sub>opt</sub> RRf	0.04	T <sub>opt</sub> RBC	0.01
w.TP.outC	0.03	T <sub>opt</sub> Rf	0.01
T <sub>opt</sub> RBC	0.03	T <sub>opt</sub> RRf	0.01

Functional Groups: O = oyster; OIR = on-reef invertebrates; BC = blue crabs; Rf = reef-resident fish; TNP = transient non-piscivorous fish; TP = transient piscivorous fish; POC = particulate organic carbon; outC = outside source of carbon

Diet consumption parameters: w.*i.j* = percent preference of consumer *i* for prey *j*

For other parameter acronyms refer to methods section.

**Table 4 (Continued).** Ranked list of parameters for SI and RD Index sensitivities on biomass at day 1281 of transient non-piscivorous fish

<b>Parameter</b>	<b>SI Index</b>	<b>Parameter</b>	<b>RD Index</b>
w.TP.Rf	0.03	w.TP.outC	0.01
T <sub>max</sub> Rf	0.02	T <sub>max</sub> BC	0.01
T <sub>opt</sub> Rf	0.02	w.TP.Rf	0.01
T <sub>max</sub> BC	0.02	C <sub>max</sub> Rf	0.01
M <sub>loss</sub> TP	0.02	E <sub>ff</sub> Rf	0.01
C <sub>max</sub> Rf	0.02	M <sub>loss</sub> TP	0.01
E <sub>ff</sub> Rf	0.02	T <sub>max</sub> Rf	0.01
R <sub>max</sub> Rf	0.01	R <sub>max</sub> Rf	0.00
MortRf	0.01	MortRf	0.00
R <sub>max</sub> BC	0.01	w.Rf.ORI	0.00
w.Rf.ORI	0.01	R <sub>max</sub> BC	0.00
w.BC.Rf	0.00	w.BC.Rf	0.00
w.TNP.BC	0.00	w.TNP.BC	0.00
K <sub>POC</sub>	0.00	K <sub>POC</sub>	0.00
w.BC.ORI	0.00	w.BC.ORI	0.00
w.Rf.POC	0.00	w.Rf.POC	0.00
w.BC.O	0.00	w.BC.O	0.00
w.TP.BC	0.00	w.TP.BC	0.00
M <sub>loss</sub> BC	0.00	M <sub>loss</sub> BC	0.00
w.BC.outC	0.00	w.BC.outC	0.00
M <sub>loss</sub> Rf	0.00	M <sub>loss</sub> Rf	0.00
w.BC.POC	0.00	w.BC.POC	0.00

Functional Groups: O = oyster; OIR = on-reef invertebrates; BC = blue crabs; Rf = reef-resident fish; TNP = transient non-piscivorous fish; TP = transient piscivorous fish; POC = particulate organic carbon; outC = outside source of carbon

Diet consumption parameters: *w.i.j* = percent preference of consumer *i* for prey *j*

For other parameter acronyms refer to methods section.



**Table 5.** Ranked list of parameters for SI and RD Index sensitivities on biomass at day 1281 of transient piscivorous fish

<b>Parameter</b>	<b>SI Index</b>	<b>Parameter</b>	<b>RD Index</b>
T <sub>opt</sub> TP	1.00	T <sub>opt</sub> TP	0.99
E <sub>ff</sub> TP	1.00	T <sub>opt</sub> RTP	0.98
C <sub>max</sub> TP	1.00	C <sub>max</sub> TP	0.90
T <sub>max</sub> TP	1.00	E <sub>ff</sub> TP	0.88
T <sub>opt</sub> RTP	1.00	R <sub>max</sub> TP	0.69
R <sub>max</sub> TP	0.98	MortTP	0.63
MortTP	0.97	T <sub>opt</sub> RRf	0.53
VX	0.79	C <sub>max</sub> Rf	0.51
E <sub>ff</sub> Rf	0.76	E <sub>ff</sub> Rf	0.51
C <sub>max</sub> Rf	0.75	T <sub>max</sub> TP	0.50
T <sub>opt</sub> RRf	0.73	VX	0.41
R <sub>max</sub> Rf	0.68	T <sub>opt</sub> Rf	0.35
MortRf	0.63	T <sub>max</sub> Rf	0.33
T <sub>max</sub> Rf	0.61	R <sub>max</sub> Rf	0.32
r <sub>O</sub>	0.60	T <sub>opt</sub> ORI	0.30
T <sub>opt</sub> Rf	0.59	MortRf	0.27
K <sub>O</sub>	0.57	r <sub>O</sub>	0.26
IO	0.52	K <sub>O</sub>	0.23
T <sub>max</sub> ORI	0.50	T <sub>max</sub> TNP	0.20
T <sub>opt</sub> ORI	0.50	IO	0.20
K <sub>outC</sub>	0.50	K <sub>outC</sub>	0.19
w.TP.outC	0.49	w.TP.outC	0.19
w.Rf.ORI	0.47	T <sub>opt</sub> TNP	0.17
T <sub>max</sub> TNP	0.42	w.Rf.ORI	0.17
w.TP.Rf	0.39	C <sub>max</sub> TNP	0.15
C <sub>max</sub> TNP	0.38	T <sub>max</sub> ORI	0.13
T <sub>opt</sub> TNP	0.36	w.TP.Rf	0.13
C <sub>max</sub> BC	0.29	T <sub>opt</sub> BC	0.12
T <sub>opt</sub> BC	0.29	C <sub>max</sub> BC	0.08
w.TNP.O	0.16	E <sub>ff</sub> TNP	0.06
MortTNP	0.15	T <sub>opt</sub> RTNP	0.06
T <sub>max</sub> BC	0.15	MortTNP	0.06

Functional Groups: O = oyster; OIR = on-reef invertebrates; BC = blue crabs; Rf = reef-resident fish; TNP = transient non-piscivorous fish; TP = transient piscivorous fish; POC = particulate organic carbon; outC = outside source of carbon

Diet consumption parameters:: w.*i.j* = percent preference of consumer *i* for prey *j*

For other parameter acronyms refer to methods section.

**Table 5 (Continued).** Ranked list of parameters for SI and RD Index sensitivities on biomass at day 1281 of transient piscivorous fish

<b>Parameter</b>	<b>SI Index</b>	<b>Parameter</b>	<b>RD Index</b>
E <sub>ff</sub> TNP	0.15	w.TNP.O	0.05
T <sub>opt</sub> RTNP	0.13	T <sub>max</sub> BC	0.05
w.TP.TNP	0.13	R <sub>max</sub> TNP	0.04
R <sub>max</sub> TNP	0.13	M <sub>loss</sub> TP	0.04
M <sub>loss</sub> TP	0.13	w.TP.TNP	0.04
w.BCRf	0.10	w.BC.Rf	0.03
E <sub>ff</sub> BC	0.09	E <sub>ff</sub> BC	0.03
w.BCoys	0.07	w.BC.O	0.02
M <sub>loss</sub> Rf	0.07	M <sub>loss</sub> Rf	0.02
w.TNPotherORI	0.06	w.TNP.ORI	0.02
w.BCotherORI	0.03	w.BC.ORI	0.01
K <sub>POC</sub>	0.03	K <sub>POC</sub>	0.01
w.RfPOC	0.03	w.Rf.POC	0.01
M <sub>loss</sub> TNP	0.01	M <sub>loss</sub> TNP	0.00
w.BC.outC	0.01	w.BC.outC	0.00
MortBC	0.01	T <sub>opt</sub> RBC	0.00
w.TNP.outC	0.01	MortBC	0.00
T <sub>opt</sub> BC.resp	0.01	w.TNP.outC	0.00
R <sub>max</sub> BC	0.00	R <sub>max</sub> BC	0.00
w.BC.POC	0.00	w.BC.POC	0.00
w.TNP.BC	0.00	w.TNP.BC	0.00
w.TP.BC	0.00	w.TP.BC	0.00
M <sub>loss</sub> BC	0.00	M <sub>loss</sub> BC	0.00

Functional Groups: O = oyster; OIR = on-reef invertebrates; BC = blue crabs; Rf = reef-resident fish; TNP = transient non-piscivorous fish; TP = transient piscivorous fish; POC = particulate organic carbon; outC = outside source of carbon  
Diet consumption parameters: w.i.j = percent preference of consumer i for prey j  
For other parameter acronyms refer to methods section

## Appendix I

### Logistic and Gompertz Growth Comparison

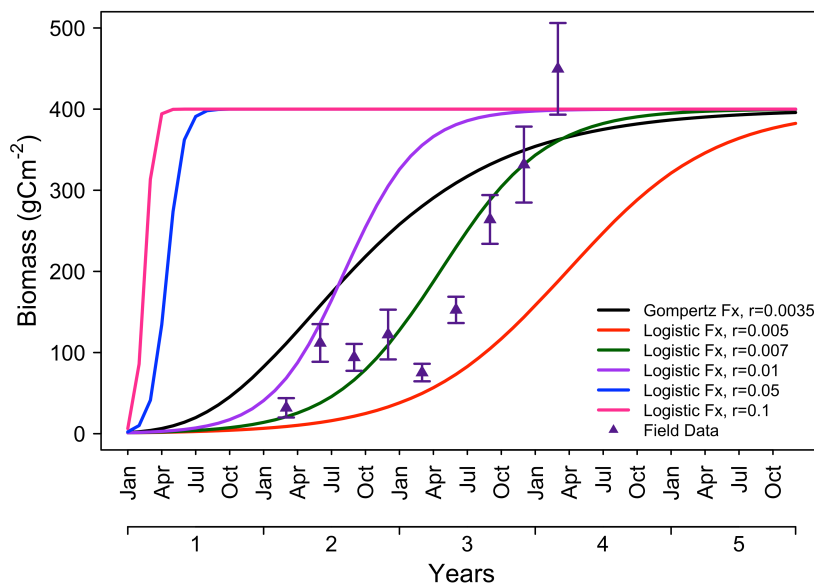
The logistic and Gompertz growth functions use the same number of parameters:  $B_0$  is the total oyster biomass ( $\text{gC} \cdot \text{m}^{-2}$ ),  $r_0$  is the growth rate of oysters ( $\text{gC} \cdot \text{gC}^{-1} \cdot \text{day}^{-1}$ ), and  $K_0$  is the carrying capacity of oysters ( $\text{gC} \cdot \text{m}^{-2}$ ). However, each equation is written in a different form. Logistic growth is defined as:

$$\frac{dB_0}{dt} = r_0 \times B_0 \times \left(1 - \frac{B_0}{K_0}\right) \quad (1)$$

And Gompertz growth is defined as:

$$\frac{dB_0}{dt} = r_0 \times B_0 \times [\log(K_0) - \log(B_0)] \quad (2)$$

A comparison of the mathematical properties of Gompertz and logistic function are presented in Winsor (1932), and Tsoularis and Wallace (2002). The plot below depicts the comparison of both functions to describe oyster growth. The carrying capacity was set at  $400\text{gCm}^{-2}$  for all functions, the Gompertz function shown uses the  $r_0$  value selected for the final model (Table 3), and the  $r_0$  values selected for the different logistic functions are shown in the figure legend. The main difference among all the functions is the growth of biomass during the first 2.5 years. I selected the Gompertz function because of its higher biomass during the first 2.5 years, without the sharp increase generated by a logistic growth model. Either function could be used to describe growth over time, but ultimately I decided that the Gompertz growth function better depicted the oyster growth during years 2.5 based on the plot below.



### **Outside Carbon Equation**

$$\frac{dB_{OC}}{dt} = B_{OC} \times \left(1 - \frac{B_{OC}}{K_{OC}}\right) \quad (3)$$

$B_{OC}$  is the availability of outside carbon, and  $K_{OC}$  is the carrying capacity of the outside carbon source. This function describes carbon as a source that quickly reaches its carrying capacity ( $K_{OC}$ ) and stays at this level for the model duration.

### **POC Equation**

$$\frac{dB_{POC}}{dt} = B_{POC} \times \left(1 - \frac{B_{POC}}{K_{POC}}\right) + 0.75 \left(Mort_i + (0.10 \times Oyst_{growth})\right) - 0.01B_{POC} - Pred_{POC} \quad (4)$$

$B_{POC}$  is the availability of POC, and  $K_{POC}$  is the carrying capacity of POC,  $Mort_i$  is natural mortality from all functional groups except oysters,  $Oyst_{growth}$  is the natural growth of oysters (equation 2) so that oyster natural mortality is considered to be 10% of their total growth, and  $Pred_{POC}$  is POC predated by other functional groups. This function describes POC as growing exponentially until reaching its carrying capacity, with 75% of daily mortality being converted to POC, 1% of daily POC is lost from the system, and POC predated is lost from the system.

### **Literature Cited**

Tsoularis A, Wallace J. 2002. Analysis of logistic growth models. *Mathematical biosciences* 179: 21-55.

Winsor CP. 1932. The Gompertz curve as a growth curve. *Proceedings of the National Academy of Sciences of the United States of America* 18: 1.

## Appendix li

Code used for oyster reef trophic bioenergetic model

```
#Code for Oyster Reef Model

#####
#PARAMETERS
#####
parameters.reef = c(

  #####
  #Oysters
  #####
  r.oyster = 0.0035, #gC/gCday
  oyster.cc = 600, # half saturation constant of oysters

  #####
  #Inverts
  #####
  #temperature dependence function
  tmax.invert = 40, #max temperature for consumption and respiration (C)
  topt.invert = 30, #optimum temperature for consumption (C)
  invoys.ratio = 0.5,

  #####
  #Blue Crabs
  #####
  Cmax.bcrab = 0.08, #0.0406, #max consumption rate (gC/gC*day)
  Rmax.bcrab = 0.02, #max respiration rate (gC/gCday)
  w.bcrabotherinvert = 0.15, #blue crab preference for other inverts
  w.bcrabboys = 0.15, #blue crab preference for other inverts
  w.bcrabPOC = 0.10, #blue crab preference for POC
  w.bcrabrfish = 0.1, #blue crab preference for other fish
  w.bcraboutC = 0.5, #blue crab preference for outside C
  efficiency.bcrab = 0.45, #blue crab efficiency of assimilation
  mortality.bcrab = 0.01, #mortality losses (1/day)
  bcrab.mloss = 0.02, #losses due to excretion and metabolic processes
  #temperature dependence function
  tmax.bcrab = 39, #max temperature for consumption and respiration (C)
  topt.bcrab = 31, #optimum temperature for consumption (C)
  topt.bcrab.resp = 34, #optimum temperature for respiration

  #####
  #Reef Associated Fish
  #####
  Cmax.rfish = 0.15, #max consumption rate (gC/gC*day)
  Rmax.rfish = 0.034, #max respiration rate (gC/gCday)
```

```

w.rfishPOC = 0.4, #preferece for POC by small fish
w.rfishotherinvert= 0.6, #preferece for other inverts by small fish
efficiency.rfish = 0.58, # efficiecnny of assimilation and handling prey
mortality.rfish = 0.01, #mortality losses (1/day)
rfish.mloss = 0.025, #Losses due to excretion amnd etabolic processes
#Temperature dependence parameters
tmax.rfish = 34, #max temperature for consumption and respiration (C)
topt.rfish = 27, #optimum temperature for consumption (C)
topt.rfish.resp = 29, #optimum temperature for respiration

#####
#Transcient NON Piscivorous Fish
#####
Cmax.mfish = 0.13, #max consumption rate (gC/gC*day)
Rmax.mfish = 0.03, #max respiration rate (gC/gCday)
w.mfishotherinvert = 0.25, #preferece for other inverts by medium fish
w.mfishoutC = 0.5, #preferece for outside C by medium fish
w.mfishhoys = 0.15, #preferece for oysters by medium fish
w.mfishbcrab = 0.1, #preferece for blue crabs by medium fish
efficiency.mfish = 0.6, #medium fish efficiency of assimilation and handlin
g prey
mortality.mfish = 0.015, #mortality losses (1/day)
mfish.mloss = 0.03, #Losses due to excretion and metabolic processes
#temperature dependence function
tmax.mfish = 34, #max temperature for consumption and respiration (C)
topt.mfish = 27, #optimum temperature for consumption (C)
topt.mfish.resp = 29, #optimum temperature for respiration

#####
#Transcient Piscivorous Fish
#####
Cmax.bfish = 0.11, #max consumption rate (gC/gC*day)
Rmax.bfish = 0.03, #max respiration rate (gC/gCday)
w.bfishmfish = 0.1, #preferece for medium fish by big fish
w.bfishrfish = 0.3, #preferece for smallfish by big fish
w.bfishoutC = 0.55, #preferece for outside C by big fish
w.bfishbcrab = 0.05, #preference for blue crabs by big fish
efficiency.bfish = 0.7, #big fish efficiency of assimilation
mortality.bfish = 0.01, #mortality losses (1/day)
bfish.mloss = 0.025, #Losses due to excretion and metabolic processes
#temperature dependence function
tmax.bfish = 34, #max temperature for consumption and respiration (C)
topt.bfish = 28, #30, #optimum temperature for consumption (C)
topt.bfish.resp = 29, #optimum temperature for respiration

####
#Outside Carbon
####

```

```

outC.cc = 20,
POC.cc = 10,

####
#Environmental parameters and Function parameters
####
VX = 3
)

#####
#Initial Values
#####
state.reef= c(
  biomass.oyster = 1,
  biomass.invert = 1,
  biomass.bcrab = 0.03,
  POC = 10,
  biomass.rfish = 1,
  biomass.mfish = 20,
  biomass.bfish = 2,
  biomass.outsideC = 10#,
)

#####
#TIME
#####
ti = 1
tf = 366*20
time=seq(ti, tf, by=1)

#####
#TEMPERATURE FORCING FUNCTION
#####
A=(32-12.5)/2
B = (2 * pi) / ( 2* (200-16))
C = 200
D=(32+12.5)/2
TempCurveParam <- c(A, B, C, D)
TempForce <- function (time, TempCurveParam) {
  with(as.list(c(TempCurveParam)), {
    Temp = A * cos(B*(time - C)) + D
    return(Temp)  })
}

#####
#FUNCTION FOR MODEL

```

```

#####

reef.model= function(time, parameters.reef, state.reef){
  with(as.list(c(parameters.reef, state.reef)),{

    #Environmental Forcing Data
    tamb <- TempForce(time, TempCurveParam)

    #####
    #Tempmerature Forcing Functions

    #Invertebrates
    v.temperature.invert.N = (tmax.invert - tamb) / (tmax.invert - topt.inver
t)
    v.temperature.invert = ifelse(v.temperature.invert.N<0, 0, v.temperature.
invert.N)
    temperature.invert = (v.temperature.invert ^ VX) * exp (VX * (1 - v.tempe
rature.invert))

    #Blue Crabs
    v.temperature.bcrab.N = (tmax.bcrab - tamb) / (tmax.bcrab - topt.bcrab)
    v.temperature.bcrab = ifelse(v.temperature.bcrab.N<0, 0, v.temperature.bc
rab.N)
    temperature.bcrab = (v.temperature.bcrab ^ VX) * exp (VX * (1 - v.tempera
ture.bcrab))

    v.temperature.bcrab.respN = (tmax.bcrab - tamb) / (tmax.bcrab - topt.bcrab
b.resp)
    v.temperature.bcrab.resp = ifelse(v.temperature.bcrab.respN<0, 0, v.tempe
rature.bcrab.respN)
    temperature.bcrab.resp = (v.temperature.bcrab.resp ^ VX) * exp (VX * (1 -
v.temperature.bcrab.resp))

    #Resident Fish
    v.temperature.rfish.N = (tmax.rfish - tamb) / (tmax.rfish - topt.rfish)
    v.temperature.rfish = ifelse(v.temperature.rfish.N<0, 0, v.temperature.rf
ish.N)
    temperature.rfish = (v.temperature.rfish ^ VX) * exp (VX * (1 - v.tempera
ture.rfish))

    v.temperature.rfish.respN = (tmax.rfish - tamb) / (tmax.rfish - topt.rfis
h.resp)
    v.temperature.rfish.resp = ifelse(v.temperature.rfish.respN<0, 0, v.tempe
rature.rfish.respN)
    temperature.rfish.resp = (v.temperature.rfish.resp ^ VX) * exp (VX * (1 -
v.temperature.rfish.resp))

    #Medium Fish
    v.temperature.mfish.N = (tmax.mfish - tamb) / (tmax.mfish - topt.mfish)

```



```

v.temperature.mfish = ifelse(v.temperature.mfish.N<0, 0, v.temperature.mfish.N)
temperature.mfish = (v.temperature.mfish ^ VX) * exp (VX * (1 - v.temperature.mfish))

v.temperature.mfish.respN = (tmax.mfish - tamb) / (tmax.mfish - topt.mfish.resp)
v.temperature.mfish.resp = ifelse(v.temperature.mfish.respN<0, 0, v.temperature.mfish.resp)
temperature.mfish.resp = (v.temperature.mfish.resp ^ VX) * exp (VX * (1 - v.temperature.mfish.resp))

#Big Fish
v.temperature.bfish.N = (tmax.bfish - tamb) / (tmax.bfish - topt.bfish)
v.temperature.bfish = ifelse(v.temperature.bfish.N<0, 0, v.temperature.bfish.N)
temperature.bfish = (v.temperature.bfish ^ VX) * exp (VX * (1 - v.temperature.bfish))

v.temperature.bfish.respN = (tmax.bfish - tamb) / (tmax.bfish - topt.bfish.resp)
v.temperature.bfish.resp = ifelse(v.temperature.bfish.respN<0, 0, v.temperature.bfish.resp)
temperature.bfish.resp = (v.temperature.bfish.resp ^ VX) * exp (VX * (1 - v.temperature.bfish.resp))

#####
#Prey Preferences Equations

WBCRAB = (w.bcraboys * biomass.oyster) + (w.bcrabotherinvert * biomass.invert) + (w.bcrabPOC * POC) + (w.bcrabrfish * biomass.rfish) + (w.bcraboutC * biomass.outsideC)
WRFISH = (w.rfishotherinvert * biomass.invert) + (w.rfishPOC * POC)
WMFISH = (w.mfishoutC * biomass.outsideC) + (w.mfishoys * biomass.oyster) + (w.mfishotherinvert * biomass.invert) + (w.mfishbcrab * biomass.bcrab)
WBFISH = (w.bfishoutC * biomass.outsideC) + (w.bfishmfish * biomass.mfish) + (w.bfishrfish * biomass.rfish) + (w.bfishbcrab * biomass.bcrab)

#####
#Oysters

#Growth
oyster.growth = r.oyster * biomass.oyster * (log (oyster.cc) - log(biomass.oyster))

#Predation Losses
oyster.predloss = ((Cmax.bcrab * temperature.bcrab * w.bcraboys * biomass.bcrab) / (biomass.bcrab + WBCRAB)) +

```

```

    ((Cmax.mfish * temperature.mfish * w.mfishoys * biomass.mfish) / (bioma
ss.mfish + WMFISH))

#####
#Inverts

#Growth
invert.cc = invoys.ratio * biomass.oyster
invert.growth = biomass.invert * (1 - (biomass.invert/invert.cc)) * temp
erature.invert

#Predation Losses
invert.predloss = ((Cmax.rfish * temperature.rfish * w.rfishotherinvert *
biomass.rfish) / (biomass.rfish + WRFISH)) +
    ((Cmax.bcrab * temperature.bcrab * w.bcrabotherinvert * biomass.bcrab)
/ (biomass.bcrab + WBCRAB)) +
    ((Cmax.mfish * temperature.mfish * w.mfishotherinvert * biomass.mfish)
/ (biomass.mfish + WMFISH))

#####
#POC

#Growth
POC.growth = POC*(1- (POC/POC.cc))

#Predation Loss
POC.predloss = ((Cmax.rfish * temperature.rfish * w.rfishPOC * biomass.rf
ish) / (biomass.rfish + WRFISH)) +
    ((Cmax.bcrab * temperature.bcrab * w.bcrabPOC * biomass.bcrab) / (bioma
ss.bcrab + WBCRAB))

#####
#Blue Crabs

#Growth
bcrab.consumption = Cmax.bcrab * temperature.bcrab * (
    ((w.bcraboys * efficiency.bcrab * biomass.oyster) / (biomass.bcrab +
WBCRAB)) +
    ((w.bcrabotherinvert * efficiency.bcrab * biomass.invert) / (biomass.
bcrab + WBCRAB)) +
    ((w.bcrabPOC * efficiency.bcrab * POC) / (biomass.bcrab + WBCRAB)) +
    ((w.bcrabrfish * efficiency.bcrab * biomass.rfish) / (biomass.bcrab +
WBCRAB)) +
    ((w.bcraboutC * efficiency.bcrab * biomass.outsideC) / (biomass.bcrab
+ WBCRAB))
    )

#Respiration
bcrab.resprate = Rmax.bcrab * temperature.bcrab.resp

```

```

    #Predation Losses
    bcrab.predloss = ((Cmax.mfish * temperature.mfish * w.mfishbcrab * biomass.mfish) / (biomass.mfish + WMFISH)) +
        ((Cmax.bfish * temperature.bfish * w.bfishbcrab * biomass.bfish) / (biomass.bfish + WBFISH))

    #####
    #Reef Fish

    #Growth
    rfish.consumption = Cmax.rfish * temperature.rfish * (
        ((w.rfishPOC * efficiency.rfish * POC) / (biomass.rfish + WRFISH)) +
        ((w.rfishotherinvert * efficiency.rfish * biomass.invert) / (biomass.rfish + WRFISH))
    )

    #Respiration
    rfish.resprate = Rmax.rfish * temperature.rfish.resp

    #Predation Losses
    rfish.predloss = ((Cmax.bcrab * temperature.bcrab * w.bcrabrfish * biomass.rfish) / (biomass.bcrab + WBCRAB)) +
        ((Cmax.bfish * temperature.bfish * w.bfishrfish * biomass.bfish) / (biomass.bfish + WBFISH))

    #####
    #Medium Fish

    #Growth
    mfish.consumption = Cmax.mfish * temperature.mfish * (
        ((w.mfishoutC * efficiency.mfish * biomass.outsideC) / (biomass.mfish + WMFISH)) +
        ((w.mfishoys * efficiency.mfish * biomass.oyster) / (biomass.mfish + WMFISH)) +
        ((w.mfishotherinvert * efficiency.mfish * biomass.invert) / (biomass.mfish + WMFISH)) +
        ((w.mfishbcrab * efficiency.mfish * biomass.bcrab) / (biomass.mfish + WMFISH))
    )

    #Respiration
    mfish.resprate = Rmax.mfish * temperature.mfish.resp

    #Predation Losses
    mfish.predloss = (Cmax.bfish * temperature.bfish * w.bfishmfish * biomass.bfish) / (biomass.bfish + WBFISH)

```

```

#####
#Big Fish

#Growth
bfish.consumption = Cmax.bfish * temperature.bfish * (
    ((w.bfishoutC * efficiency.bfish * biomass.outsideC) / (biomass.bfish
+ WBFISH)) +
    ((w.bfishmfish * efficiency.bfish * biomass.mfish) / (biomass.bfish +
WBFISH)) +
    ((w.bfishrfish * efficiency.bfish * biomass.rfish) / (biomass.bfish
+ WBFISH)) +
    ((w.bfishbcrab * efficiency.bfish * biomass.bcrab) / (biomass.bfish +
WBFISH))
)

#Respiration
bfish.resprate = Rmax.bfish * temperature.bfish.resp

#####
#EQUATIONS
#####

oyster.predated = biomass.oyster * oyster.predloss

invert.predated = biomass.invert * invert.predloss

POC.predated = POC * POC.predloss

bcrab.growth = biomass.bcrab * bcrab.consumption
bcrab.mortality = biomass.bcrab * mortality.bcrab
bcrab.metabolicloss = biomass.bcrab * bcrab.consumption * bcrab.mloss
bcrab.respiration = biomass.bcrab * bcrab.resprate
bcrab.predated = biomass.bcrab * bcrab.predloss

rfish.growth = biomass.rfish * rfish.consumption
rfish.mortality = biomass.rfish * mortality.rfish
rfish.respiration = biomass.rfish * rfish.resprate
rfish.metabolicloss = biomass.rfish * rfish.consumption * rfish.mloss
rfish.predated = biomass.rfish * rfish.predloss

mfish.growth = biomass.mfish * mfish.consumption
mfish.mortality = biomass.mfish * mortality.mfish
mfish.respiration = biomass.mfish * mfish.resprate
mfish.metabolicloss = biomass.mfish * mfish.consumption * mfish.mloss
mfish.predated = biomass.mfish * mfish.predloss

```

```

bfish.growth = biomass.bfish * bfish.consumption
bfish.mortality = biomass.bfish * mortality.bfish
bfish.respiration = biomass.bfish * bfish.resprate
bfish.metabolicloss = biomass.bfish * bfish.consumption * bfish.mloss

#####
#DIFFERENTIAL EQUATIONS
#####

dBdt.oyster = oyster.growth - oyster.predated

dBdt.invert = invert.growth - invert.predated

dBdt.bcrab = bcrab.growth - bcrab.mortality - bcrab.metabolicloss - bcrab
.respiration - bcrab.predated

dPOCdt = POC.growth + 0.75 * ( (0.1 *oyster.growth) + bcrab.mortality + r
fish.mortality + mfish.mortality + bfish.mortality ) - 0.01*POC - POC.predate
d

dBdt.rfish = rfish.growth - rfish.mortality - rfish.respiration - rfish.m
etabolicloss - rfish.predated

dBdt.mfish = mfish.growth - mfish.mortality - mfish.respiration - mfish.m
etabolicloss - mfish.predated

dBdt.bfish = bfish.growth - bfish.mortality - bfish.respiration -bfish.me
tabolicloss

dBdt.outisdeC = biomass.outsideC *(1- (biomass.outsideC/outC.cc))

return(list(c(dBdt.oyster, dBdt.invert,dBdt.bcrab,
              dPOCdt, dBdt.rfish, dBdt.mfish, dBdt.bfish,dBdt.outisdeC),
           c(tamb)))
})
}

##Run Model
model.out <- ode(y=state.reef, times=time, func=reef.model, parms=parameters.
reef)

```