

THE GORDION
EXCAVATIONS, 1950-1973:
FINAL REPORTS
VOLUME IV
Illustrations

THE EARLY PHRYGIAN
POTTERY

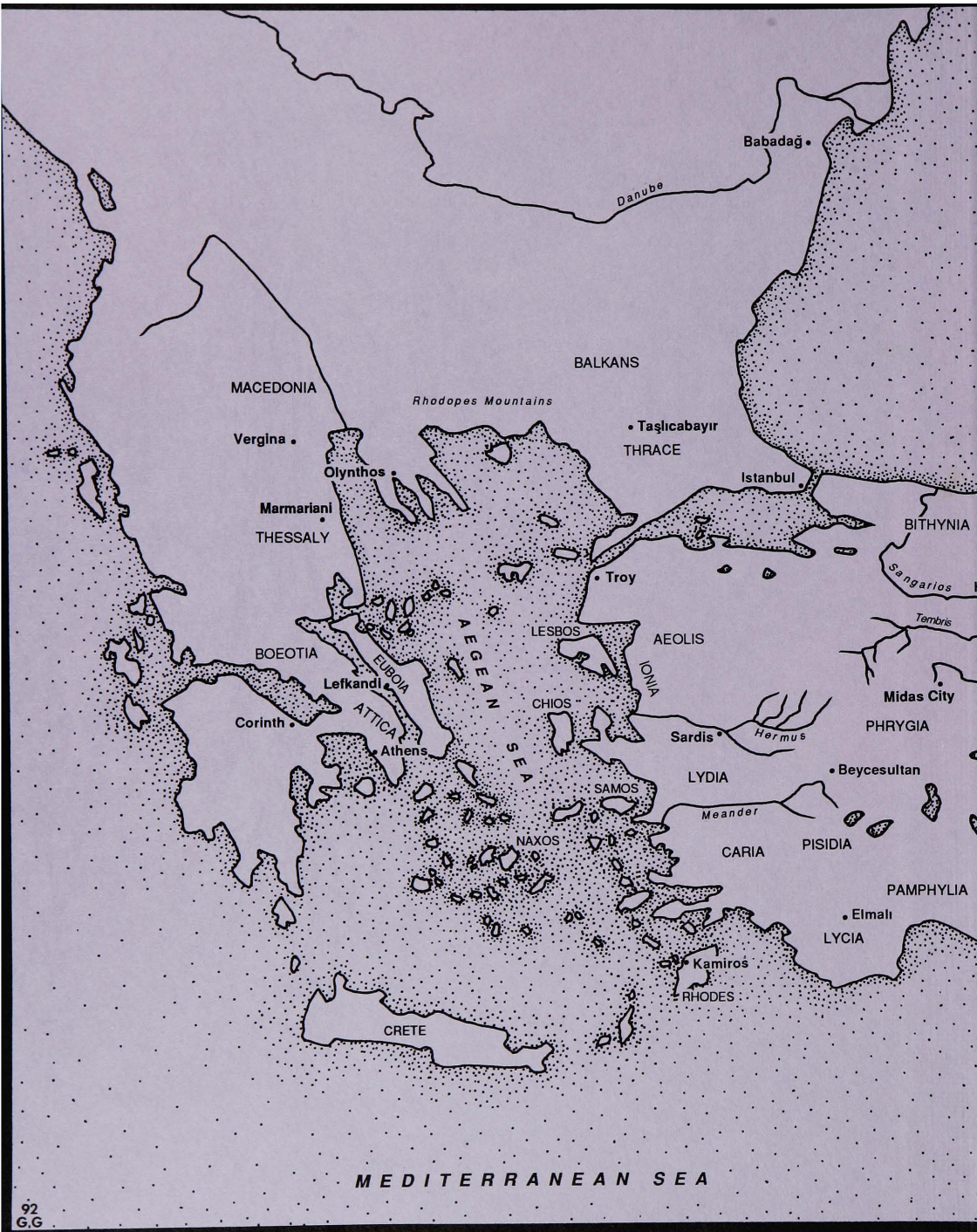



MACEDONIA

Vergina •

Marmariani •
THESSALY

BOEOTIA

Corinth •

ATTICA
Athens •

CRETE

BALKANS

Danube

Babadağ •

• Taşlıcabayır
THRACE

Istanbul •

BITHYNIA

Sangarios

Tembris

Midas City

PHRYGIA

• Beycesultan

LYDIA

Meander

CARIA

PISIDIA

PAMPHYLIA

• Elmalı
LYCIA

• Kamiros
RHODES

Rhodopes Mountains

AEGEAN SEA

LESBOS

CHIOS

SAMOS

NAXOS

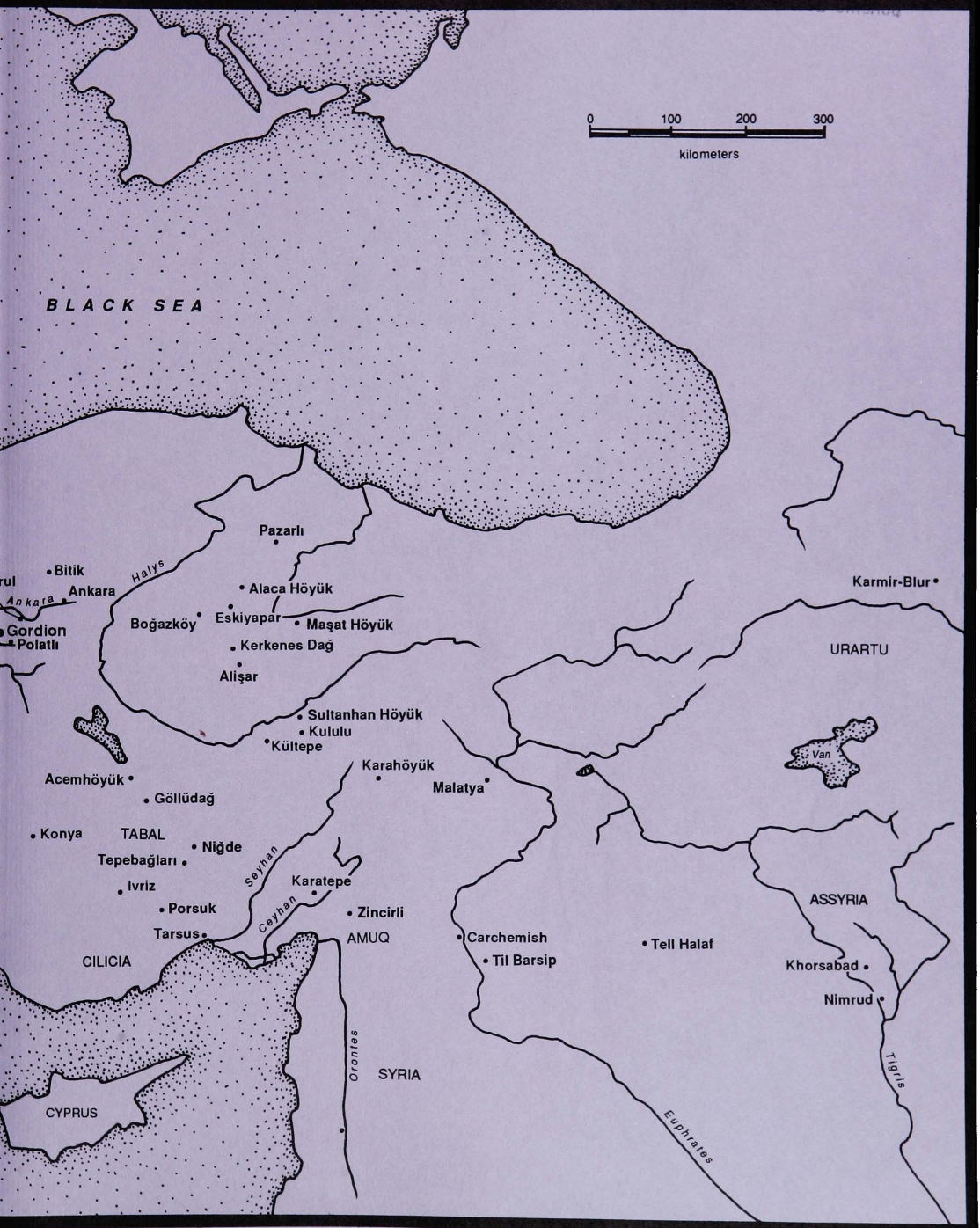

BLACK SEA

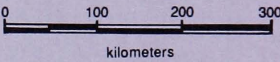

Arslan

Ankara

Gordion

Polatli

• Bitik

• Ankara

Halys

Pazarlı

• Alaca Höyük

Boğazköy

• Eskiyağar

• Maşat Höyük

• Kerkenes Dağ

• Alişar

• Sultanhan Höyük

• Kültepe

• Karahöyük

Malatya

Karmir-Blur •

URARTU

Van

Acemhöyük •

• Göllüdağ

• Konya

TABAL

• Niğde

Tepebağları •

• İvriz

• Porsuk

Tarsus •

CILICIA

Seyhan

Ceyhan

• Karatepe

• Zincirli

AMUQ

• Carchemish

• Til Barsip

• Tell Halaf

ASSYRIA

• Khorsabad

Nimrud •

CYPRUS

Orontes

SYRIA

Euphrates

Tigris

THE EARLY PHRYGIAN POTTERY

Illustrations

University Museum Monograph 79

The Gordion Excavations, 1950-1973:
Final Reports
Volume IV
Illustrations

E.L. Kohler, Editor

THE EARLY PHRYGIAN POTTERY

G. Kenneth Sams

Published by



The University Museum
University of Pennsylvania
1994

Design, editing, production
Publications Department
The University Museum

Printing
Science Press
Ephrata, Pennsylvania

Library of Congress Cataloging-in-Publication Data
(Revised for vol. 4)

The Gordion excavations.

(University Museum monograph / University Museum, University of
Pennsylvania ; 43-)

Companion set to "Gordion special studies".

Vol. : The Gordion excavations, 1950-1973.

Includes bibliographical references and index.

Contents: v. 1. Three great early tumuli / Rodney S. Young - v. 4. The early
Phrygian pottery / G. Kenneth Sams.

1. Gordion (Extinct city). 2. Turkey--Antiquities. I. Young, Rodney Stuart,
1907- II. The gordion excavations, 1950-1973. III. University Museum
monograph ; 43, etc.

DS156.G6G67 1981

939'.26

81-13373

ISBN 0-924171-18-9

Copyright © 1994
The University Museum
University of Pennsylvania
Philadelphia
All rights reserved
Printed in the United States of America

Contents

List of Color Plates	vii
List of Plans	ix
List of Figures	xi
List of Plates.	xiii
Color Plates	
Plans	
Figures	
Plates	

List of Color Plates

Color Plate I

Color Plate II

Color Plate III

List of Plans

- Plan A. Gordion, Destruction Level
- Plan B. Gordion, Pre-Terrace Phase
- Plan C. Early Phrygian Building as excavated, 1969
- Plan D. Early Phrygian Building and area to W, as excavated, 1965

List of Figures

- Figure 1. Early Phrygian Handmade, Carinated Bowls
Figure 2. Early Phrygian Handmade, Plain Bowls
Figure 3. Early Phrygian Handmade, Group 1 Closed Vessels
Figure 4. Early Phrygian Handmade, Group 2 Closed Vessels
Figure 5. Miscellaneous Handmade Vessels
Figures 6-15. Carinated Bowls
Figures 16-20. Plain Bowls
Figure 21. Bowls with Articulated Rims
Figure 21. Bowls, Miscellaneous
Figures 22-25. Round-Mouthed Jugs
Figure 26. Trefoil Jugs
Figure 27. Miscellaneous Jugs, Askos
Figures 28-30. Ambiguous Jugs
Figure 30. Side-Spouted Sieve Jugs
Figure 31. One-Handled Utility Pots
Figure 31. Stand
Figures 32-33. Miscellaneous Vessels
Figures 34-47. Amphoras
Figures 48-50. Jars
Figures 51-55. Large Vessels with Lugged Rims
Figures 56-57. Large Vessels with Unlugged Rims
Figures 58-59. Ambiguous Vessels, Miscellaneous
Figures 60-61. Stamped Motifs
Figures 62-65. Painted Motifs

List of Plates

Plate A	Storerooms behind Meg. 1
Plate B1	Megaron 4, anteroom
Plate B2	CC Building 2, E corner
Plate C	Terrace Building 2, NW aisle
Plates D1, 2	Terrace Gateway Pottery Depot
Plate E1	Terrace Gateway Pottery Depot
Plate E2	TB 5 from southwest
Plate F	Early Phrygian Building, area to W
Plate G	Meg. 10 sounding
Plate H	Citadel, aerial view
Plate 1	Early Phrygian Handmade, Carinated Bowls
Plate 2	Early Phrygian Handmade, Plain-Rimmed Bowls
Plate 3	Early Phrygian Handmade, Unclassifiable Bowl and Loop-Handled Cup
Plate 4	Early Phrygian Handmade, Group 1 Closed Vessels
Plates 5-6	Early Phrygian Handmade, Group 2 Closed Vessels
Plate 7	Early Phrygian Handmade, Ambiguous Closed Vessels
Plates 8-9	Miscellaneous Handmade Vessels
Plates 10-13	Crude Handmade Pottery
Plates 14-23	Carinated Bowls
Plate 24	Flaring-Rimmed Bowls
Plates 25-33	Plain-Rimmed Bowls
Plates 34-35	Bowls with Articulated Rims
Plate 36	Ambiguous Bowls
Plates 37-55	Round-Mouthed Jugs
Plates 56-60	Large Round-Mouthed Jugs
Plate 61	Round-Mouthed Jugs from Tumuli
Plates 62-75	Narrow-Necked Trefoil Jugs, Small and Medium
Plates 76-80	Narrow-Necked Trefoil Jugs, Large
Plates 81-85	Wide-Mouthed Trefoil Jugs
Plate 86	Miscellaneous Jugs: Narrow-Necked, Round-Mouthed
Plate 87	Miscellaneous Jugs: Spouted
Plate 88	Miscellaneous Jugs: Assorted

Plates 89-92	Ambiguous Jugs
Plate 93	Askoi
Plates 94-100	Side-Spouted Sieve Jugs
Plates 101-102	One-Handled Utility Pots
Plate 103	Lids
Plates 104-105	Miscellaneous Vessels
Plates 106-108	Stands
Plate 109	Small Amphoras
Plate 110	Kantharos Kraters
Plates 111-112	Narrow-Necked Amphoras, Neck-Handled
Plates 113-115	Narrow-Necked Amphoras, Shoulder-Handled
Plates 116-132	Open-Mouthed Amphoras
Plate 133	Amphoras in the Alişar IV Style
Plate 134	Miscellaneous and Ambiguous Amphoras
Plates 135-141	Low-Necked Jars and Dinoi
Plates 142-143	Necked Jars
Plates 144-149	Storage Jars
Plates 150-157	Ambiguous Vessels, Monochrome
Plates 158-167	Ambiguous Vessels, Painted
Plates 168-170	Details of Stamped Motifs



Color Plates



227



167

165

114



168

117

135

COLOR PLATE II



127

23

295

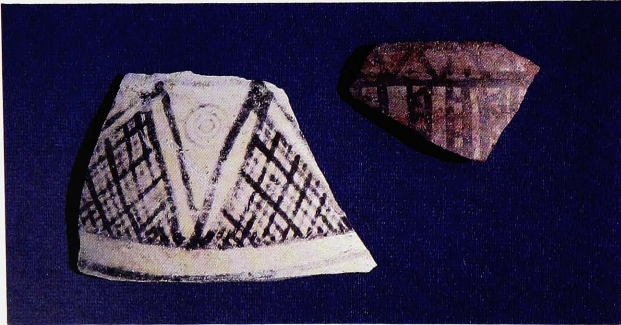

172

116



296



186

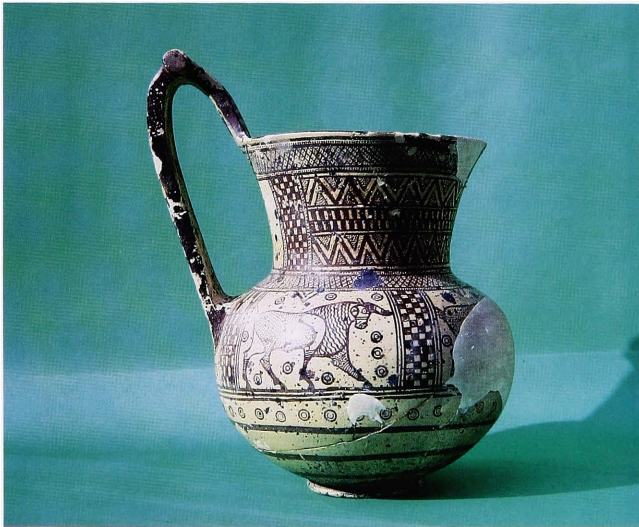

Brown-on-buff round-mouthed jug from Tumulus P (Tum P 57)

Plans

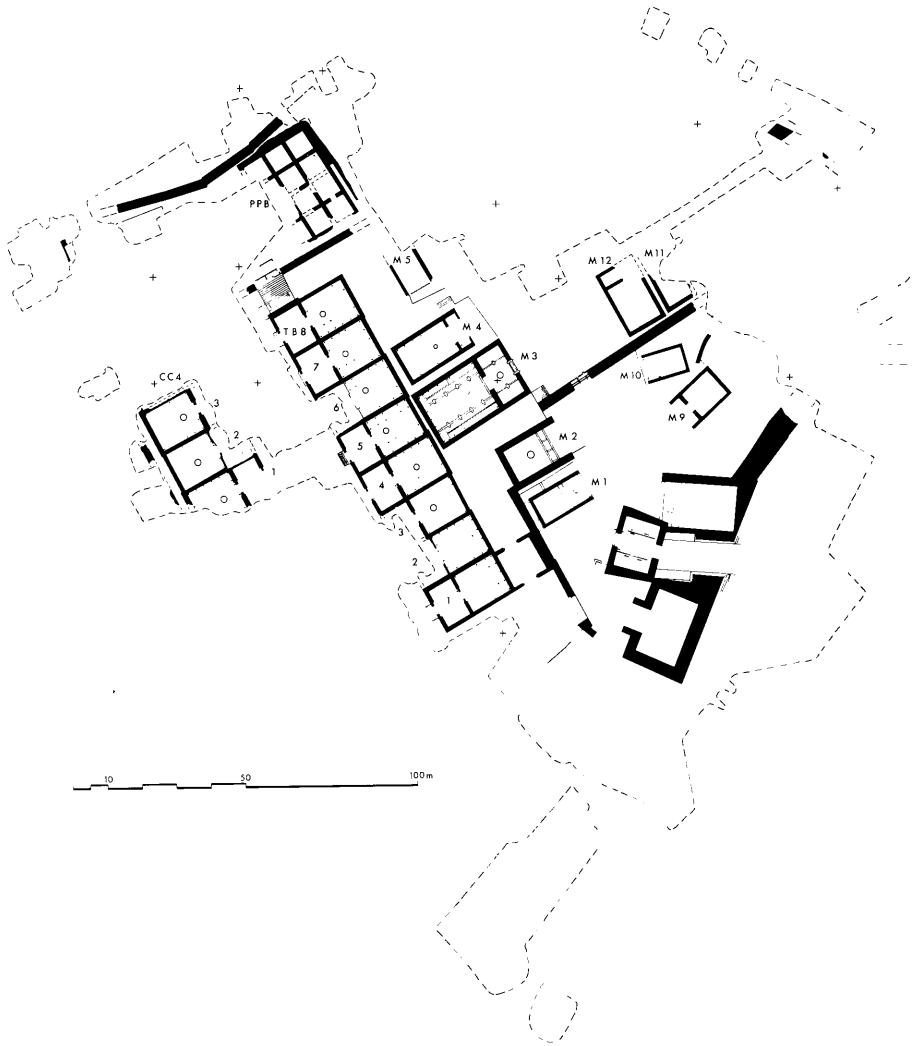

Gordion, Destruction Level

PLAN B

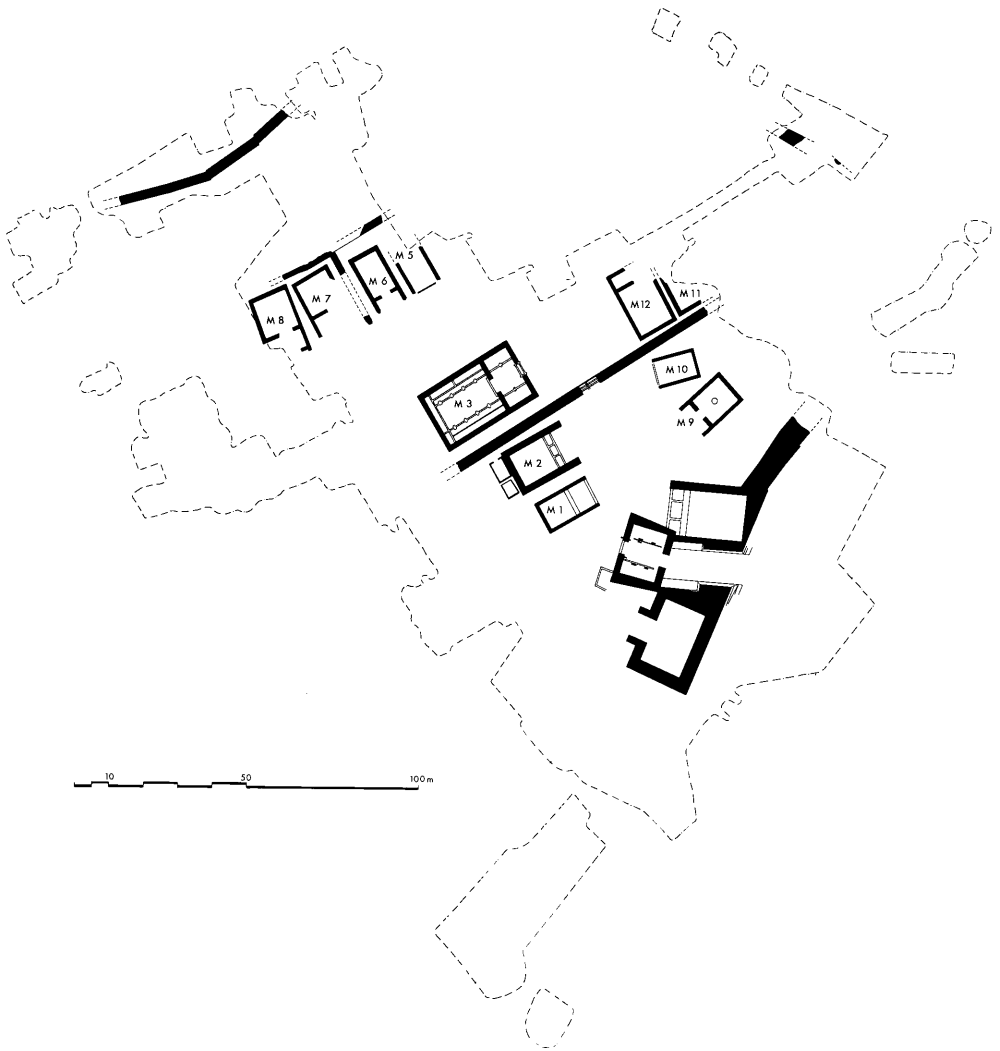

Gordion, Pre-Terrace Phase

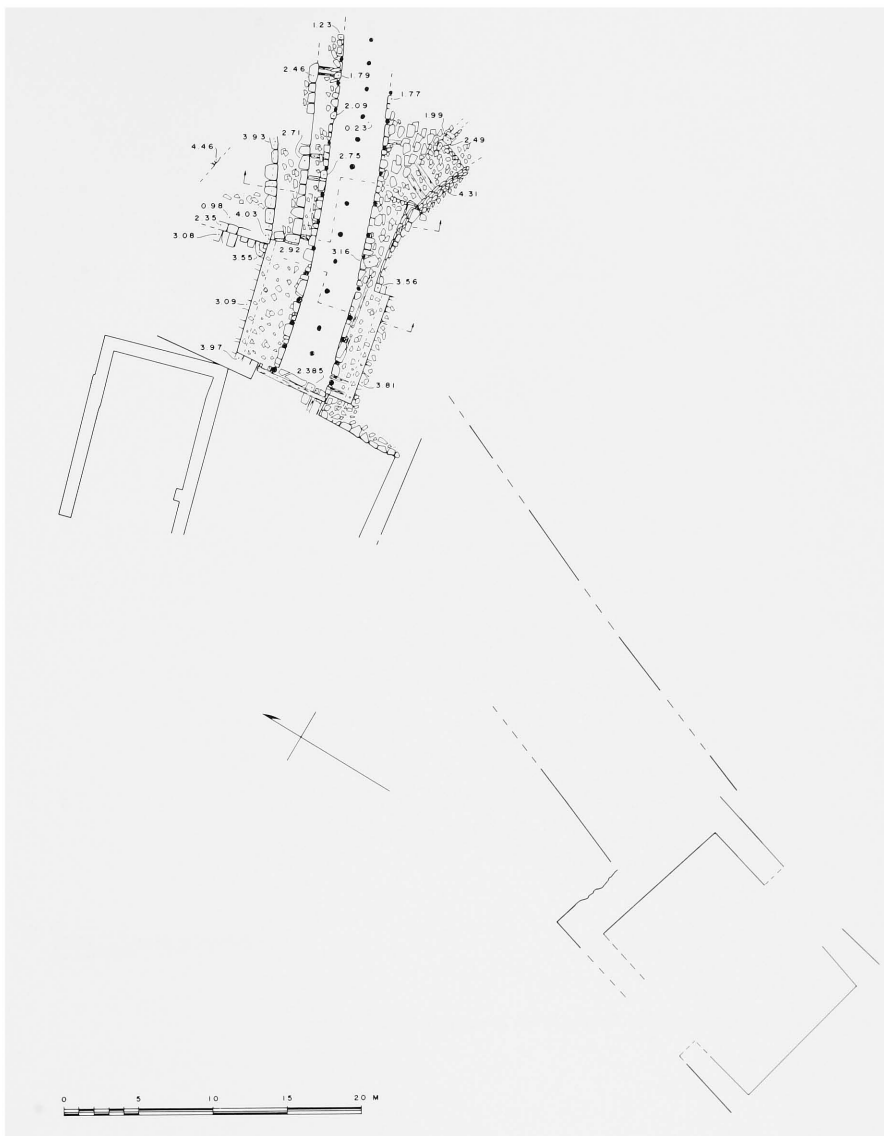

Early Phrygian Building, as excavated, 1969

PLAN D

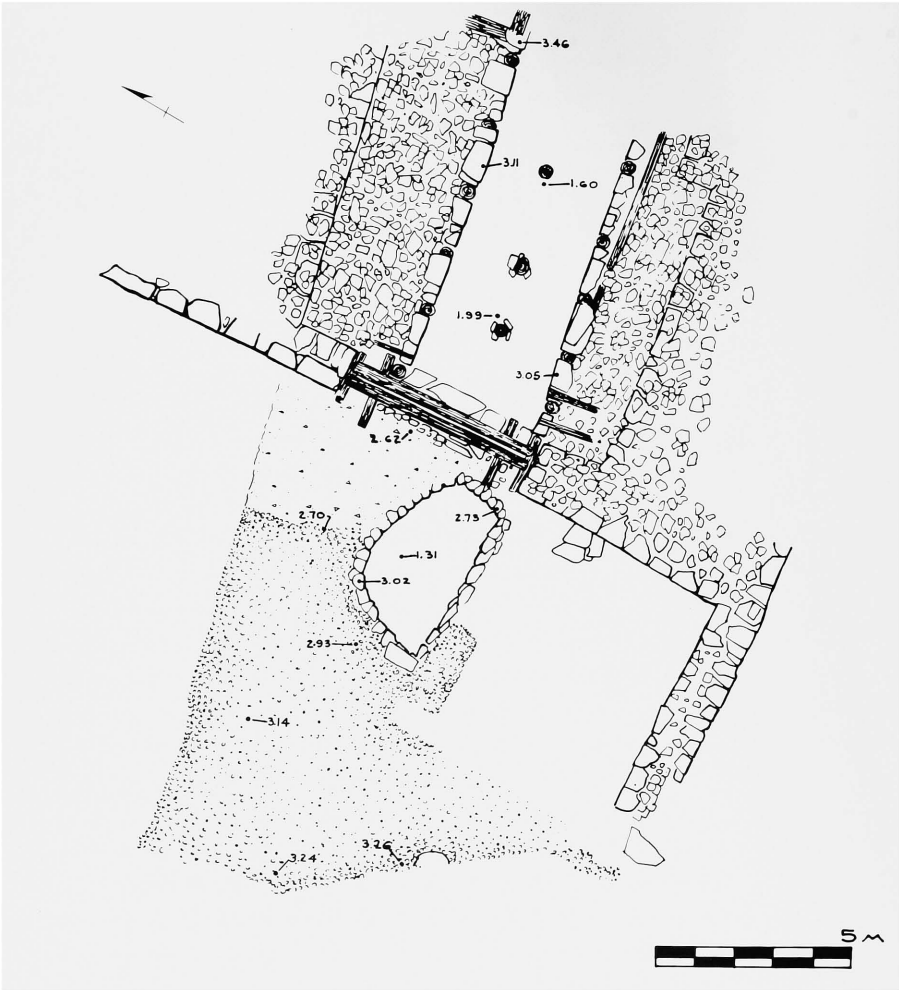

Early Phrygian Building and Area to West, as excavated 1965

Figures

CARINATED BOWLS

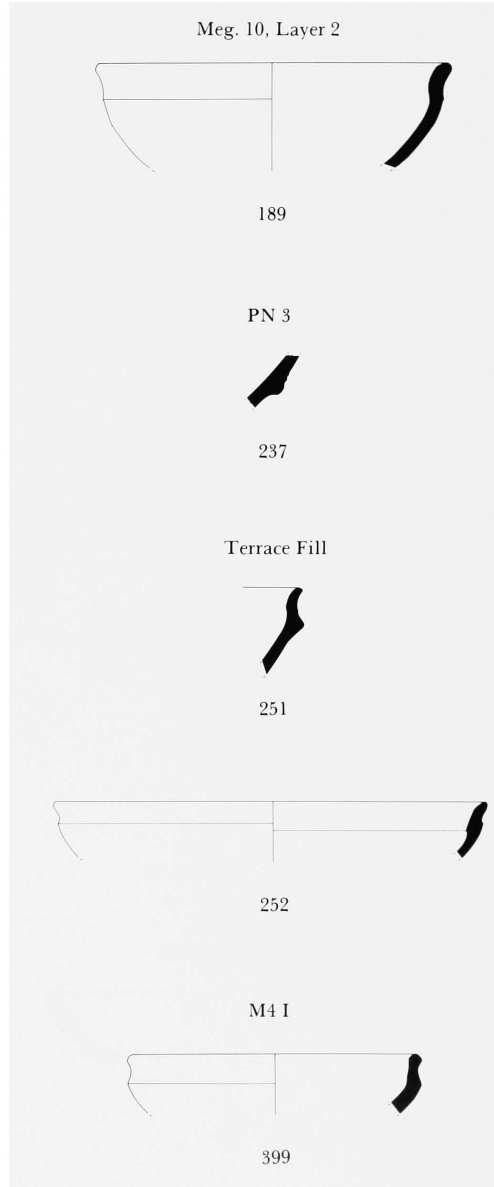
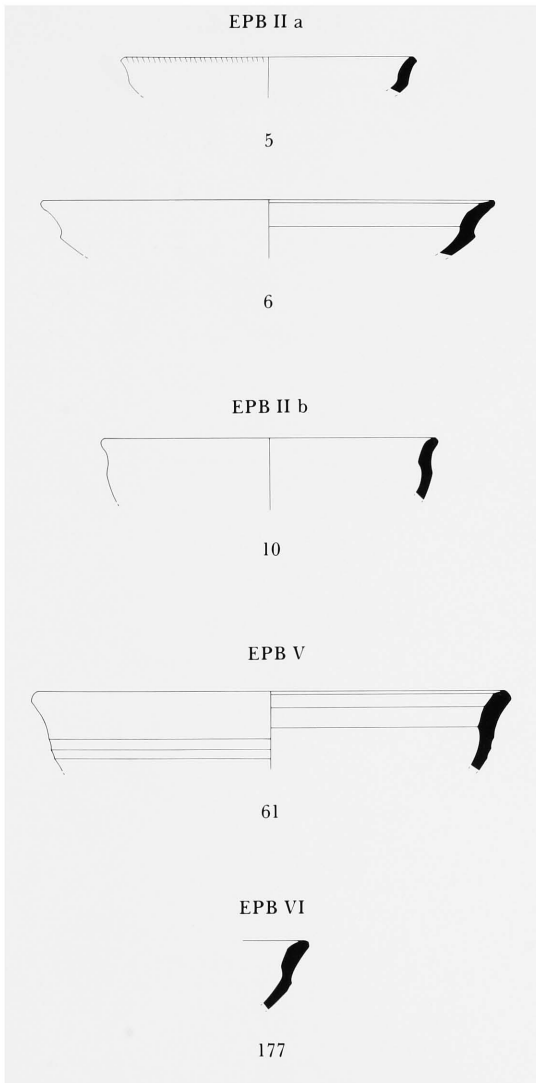

PLAIN BOWLS

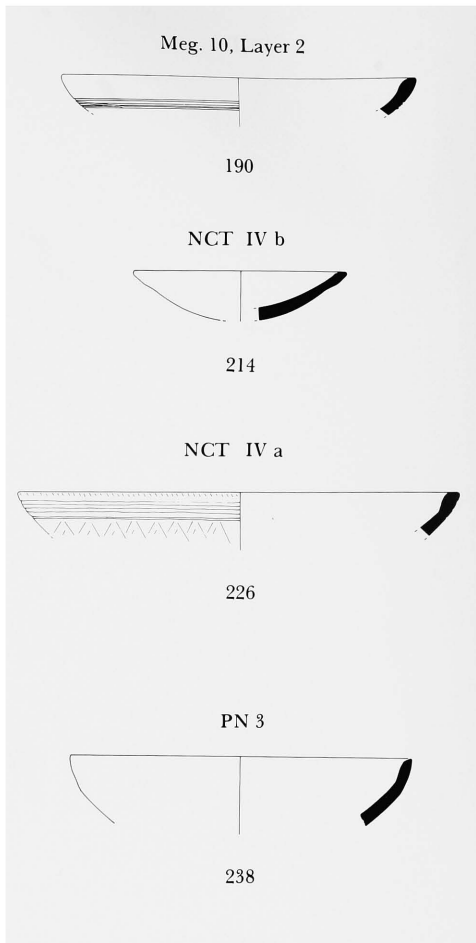
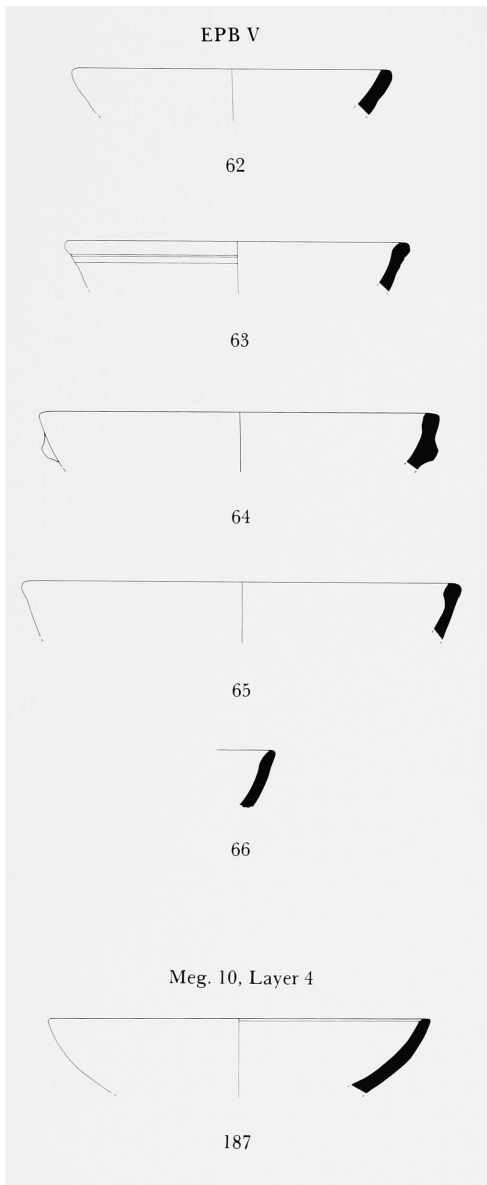

CLOSED VESSELS, GROUP 1

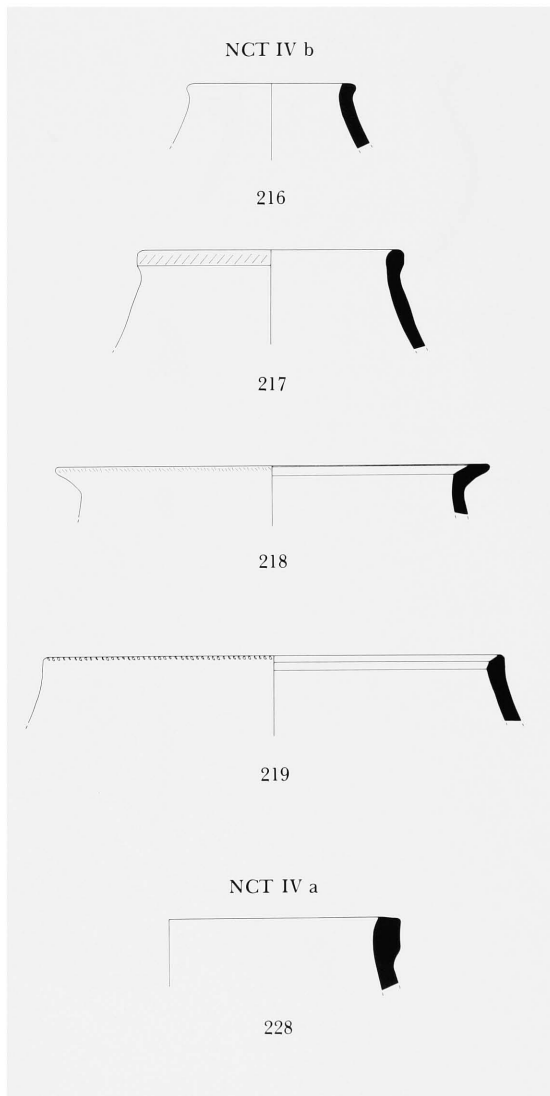
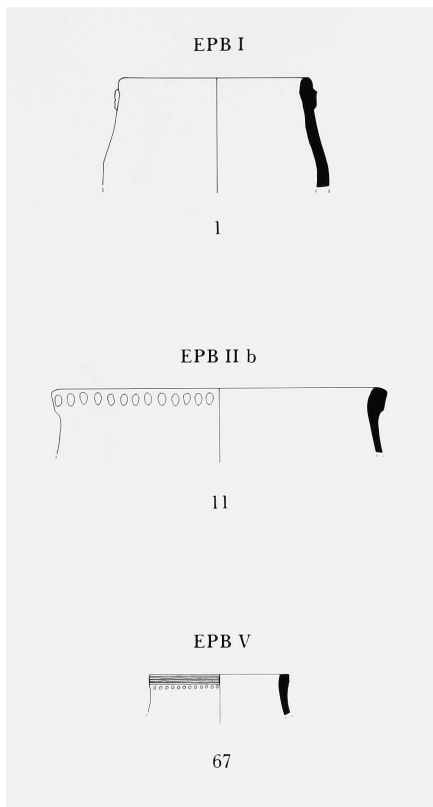

CLOSED VESSELS, GROUP 2

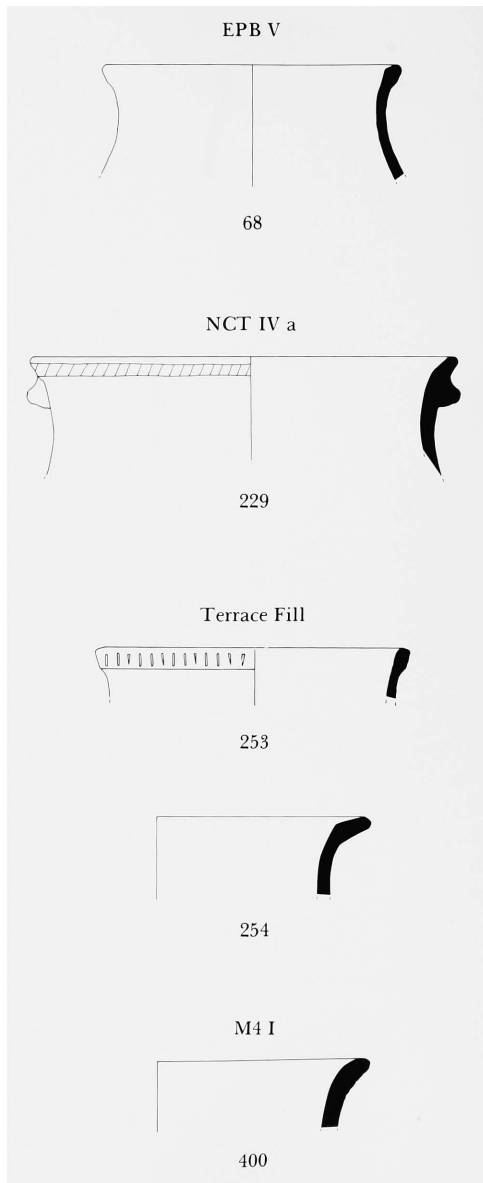
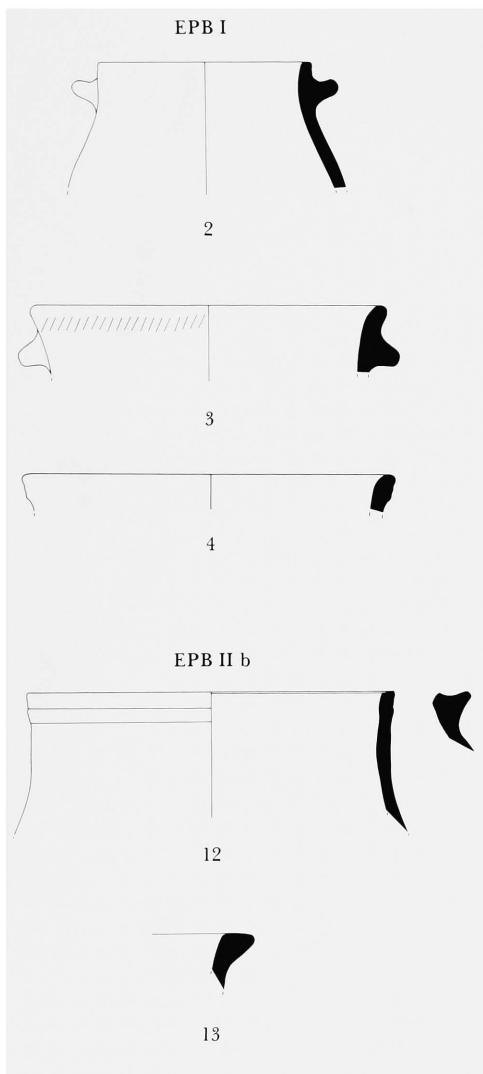

Destruction Level

Carinated Basin

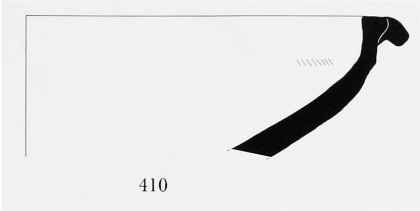

One-Handled Utility Pot



Spouted Jug

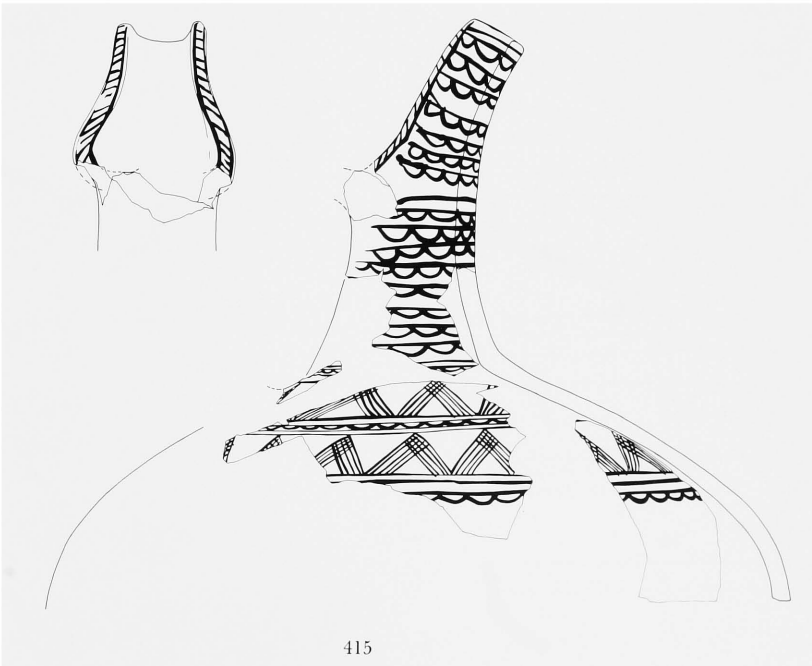
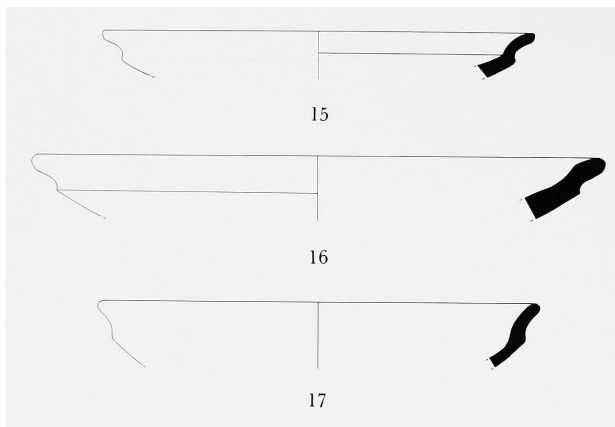

FIGURE 6

CARINATED BOWLS

EPB II b

Class 1



EPB III

Class 1

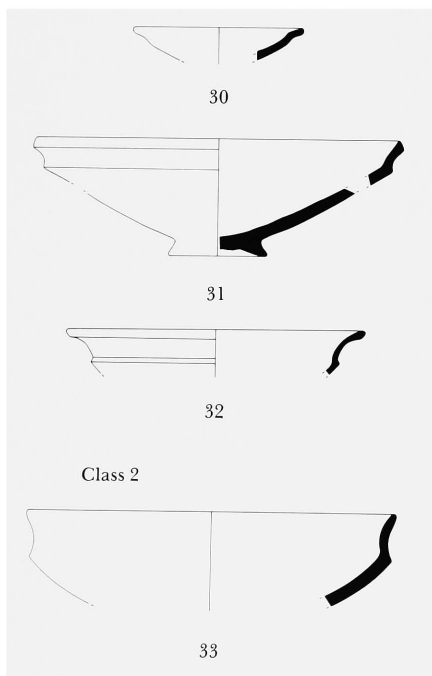

Class 2

Class 2 (continued)

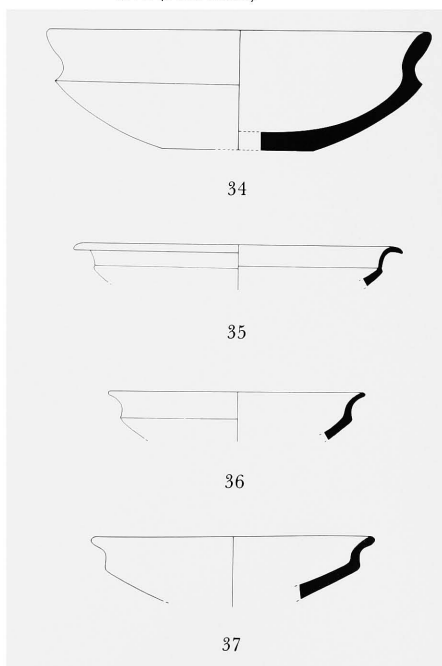

CARINATED BOWLS

FIGURE 7

EPB V

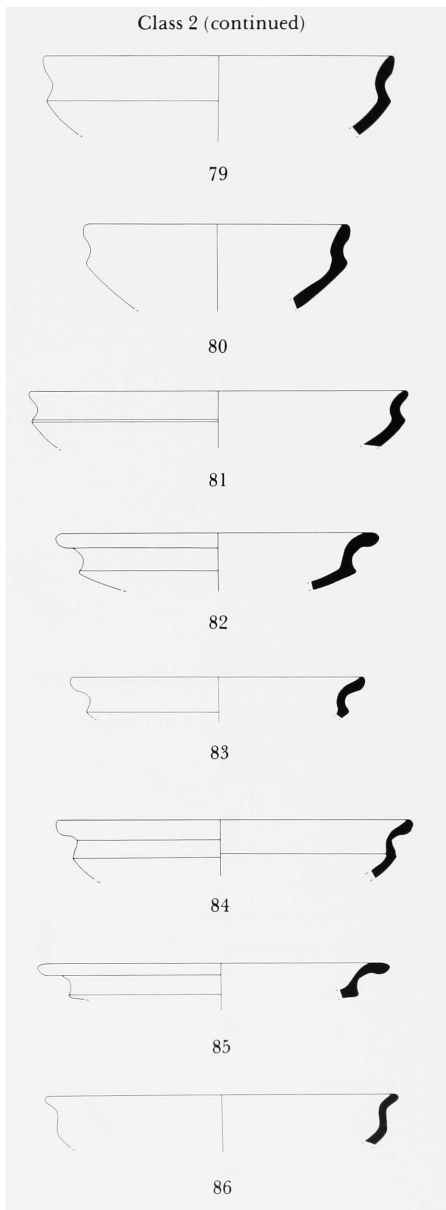
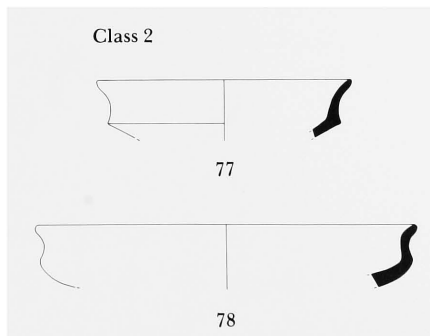
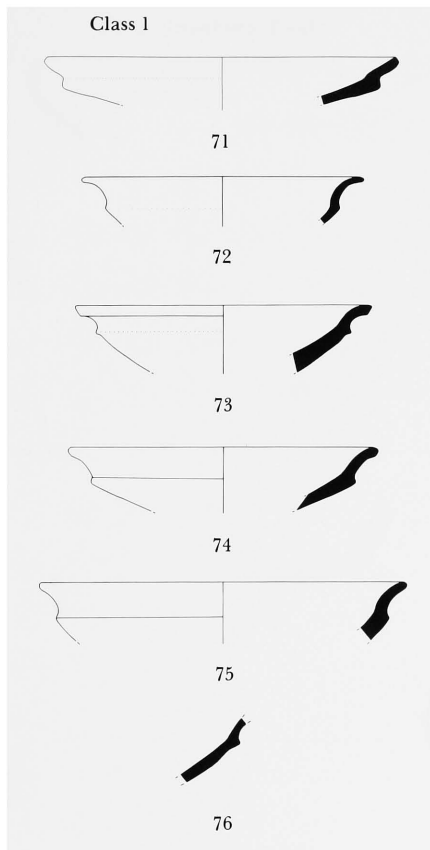

FIGURE 8

EPB V

Class 2 (continued)



87



88



89



90



91

Class 3



92



93

CARINATED BOWLS

Class 3 (continued)



94



95



96



97

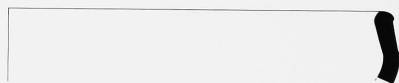

98

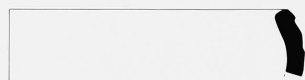

99

Meg. 10, Layer 1

Class 1

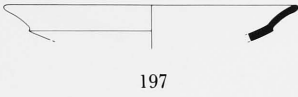

Class 2

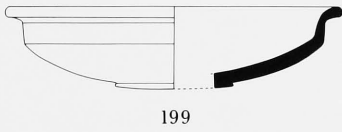
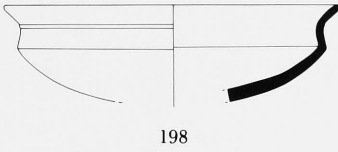

Unclassed



NCT IVa

Class 2

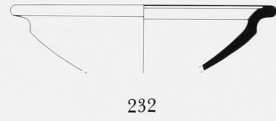

Class 3

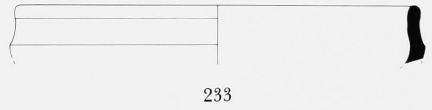

Early Bronze Trench/PN3

Class 1

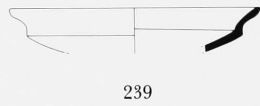

FIGURE 10

CARINATED BOWLS

Terrace Fill

Class 1



257



258



259



260



261



262



263

Class 2



264



265



266



267



268



269



270



271

CARINATED BOWLS

FIGURE 11

Terrace Fill (continued)

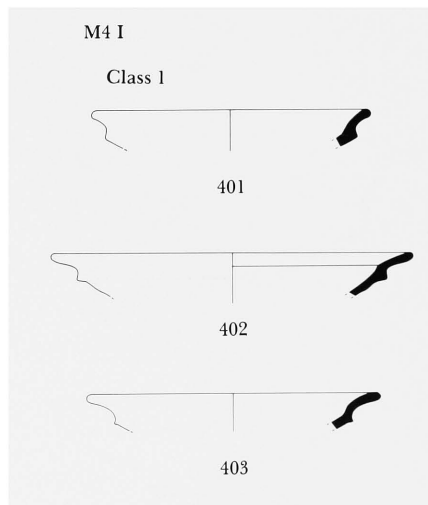
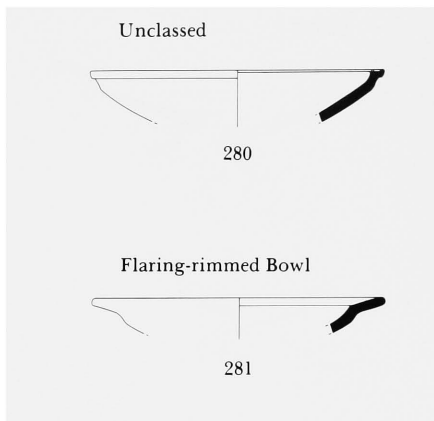
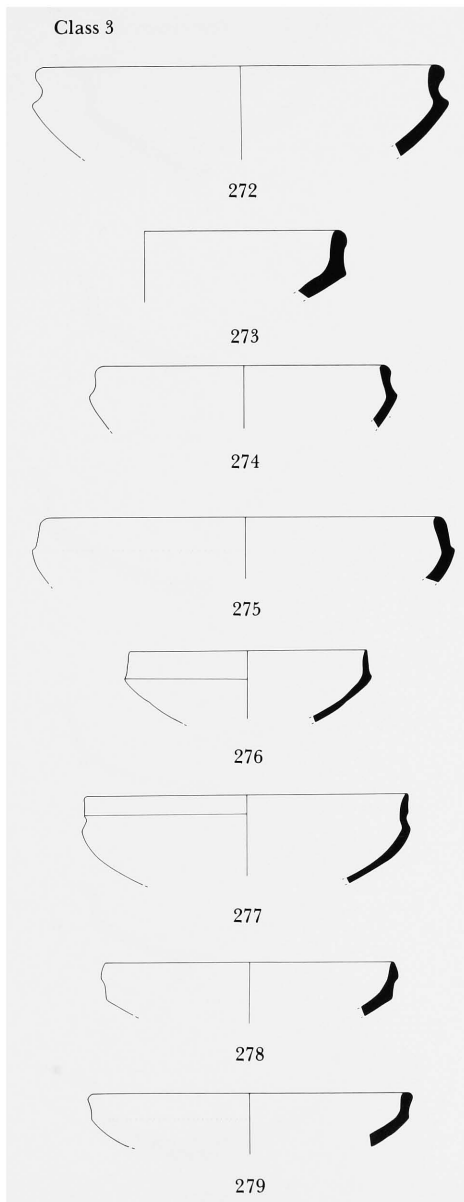

FIGURE 12

CARINATED BOWLS

Destruction Level

Class 1



435



436



437



439

Class 2

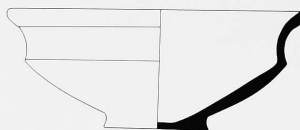

441



442

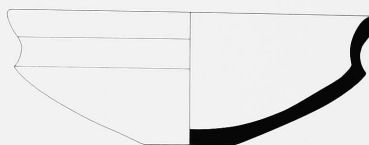

443



445



447



449

Destruction Level

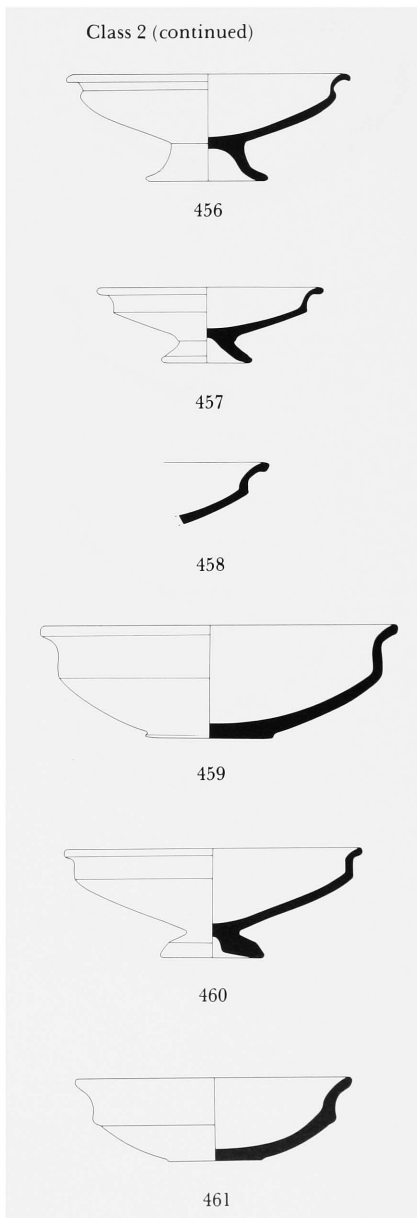
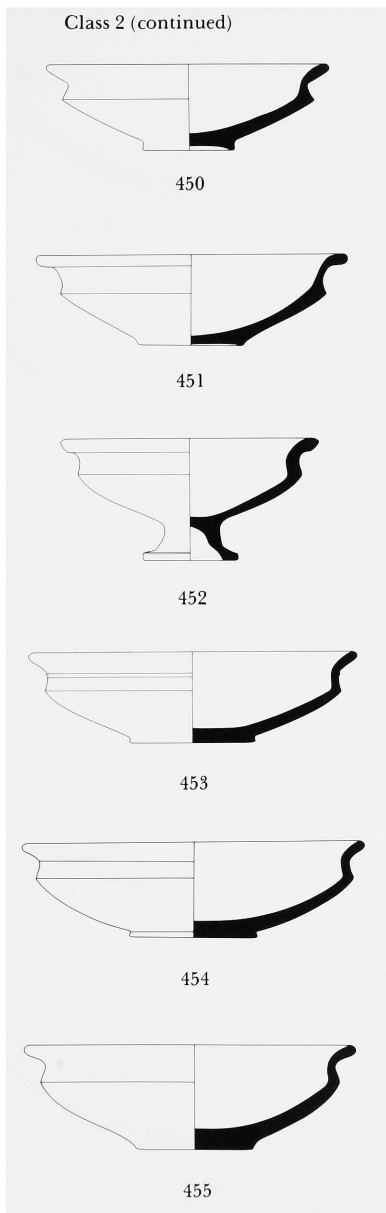

FIGURE 14

CARINATED BOWLS

Destruction Level

Class 2 (continued)



462



463



464



465



467

Class 3



468



470



471



472



473

CARINATED BOWLS

FIGURE 15

Destruction Level

Class 3 (continued)

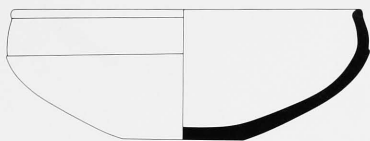

474



475

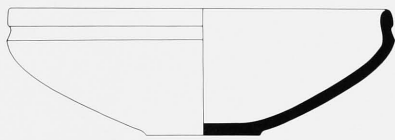

477



479



480

Class 3 (continued)



481



482

Unclassed



483

Flaring-Rimmed Bowl



485

EPB II a

Class 1

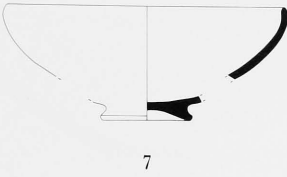

EPB II b

Class 1

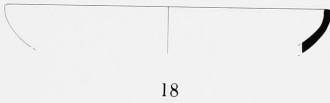

Class 2



EPB III

Class 1



EPB III

Class 1 (continued)

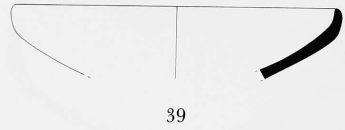

EPB V

Class 1

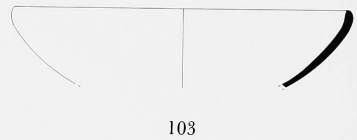

Class 2

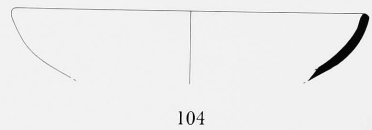

PLAIN BOWLS

FIGURE 17

EPB V (continued)

Class 3



106



107



108

EPB VI

Class 2



178



179

Meg. 10, Layer 1

Class 2



202

Class 3



203

NCT IV b

Class 2



220

Class 3



221

Terrace Fill

Class 1

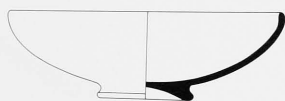

282



283



284

Class 2



285



286

Class 3



287



288

Destruction Level

Class 1



486



487



488



489



490

Destruction Level

Class 1 (continued)

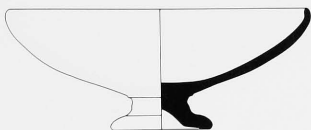

491

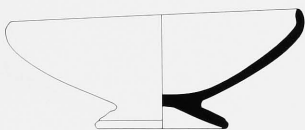

492

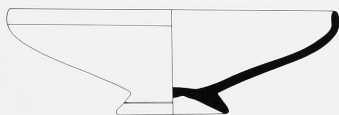

493

Class 1 (continued)

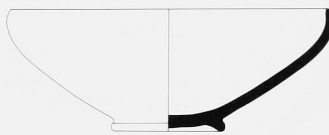

494



497

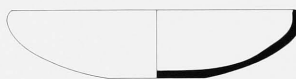

498

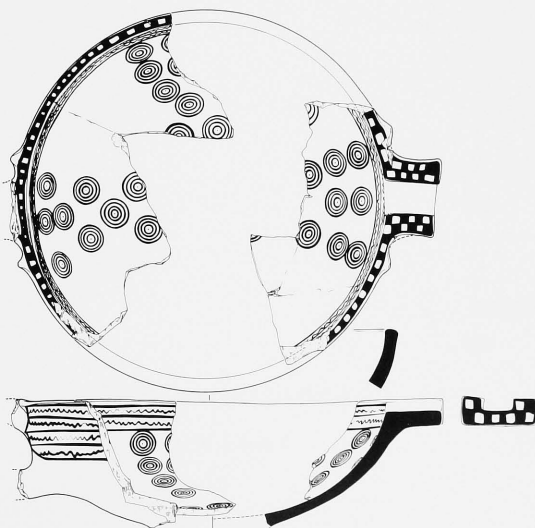

500

FIGURE 20

PLAIN BOWLS

Destruction Level

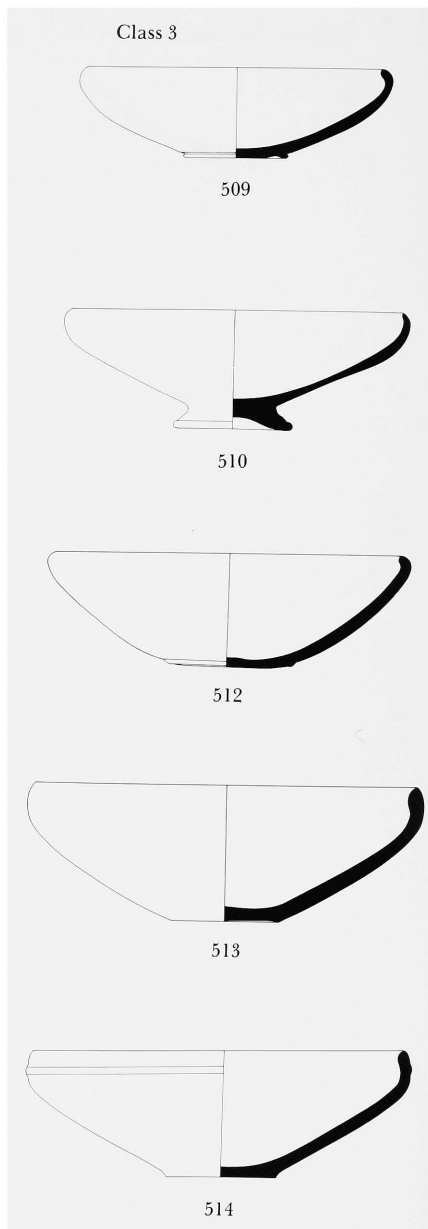
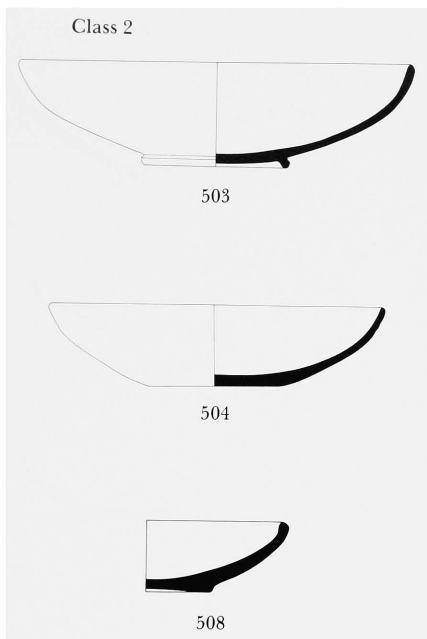

BOWLS WITH ARTICULATED RIMS

FIGURE 21

EPB II a



NCT IV a



EPB III

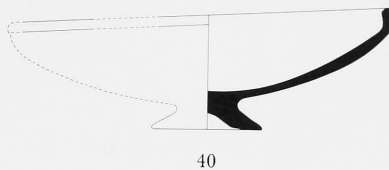

Meg. 10,
Layer 2



Destruction Level

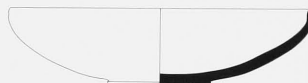

BOWLS, MISCELLANEOUS

EPB V



Meg. 10, Layer 1



Terrace Fill



EPB II b



21

EPB III



41

EPB V

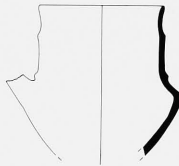

110



111



112

EPB VI

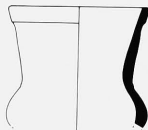

180

Terrace Fill



292



293

ROUND-MOUTHED JUGS

FIGURE 23

Destruction Level

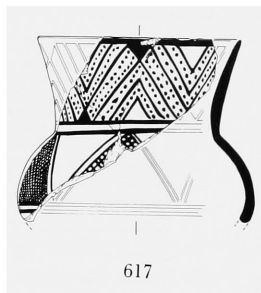
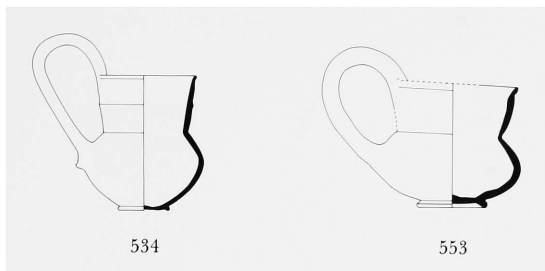

LARGE ROUND-MOUTHED JUGS

EPB III

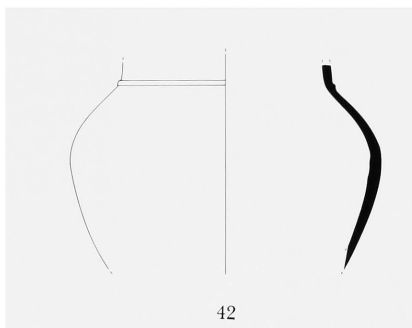

EPB V

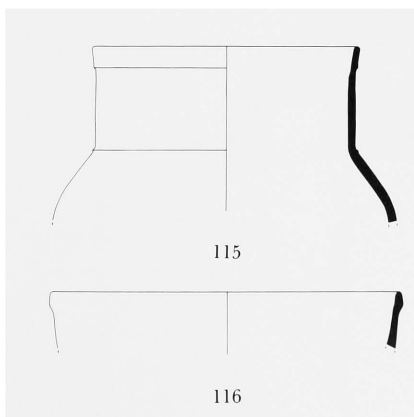
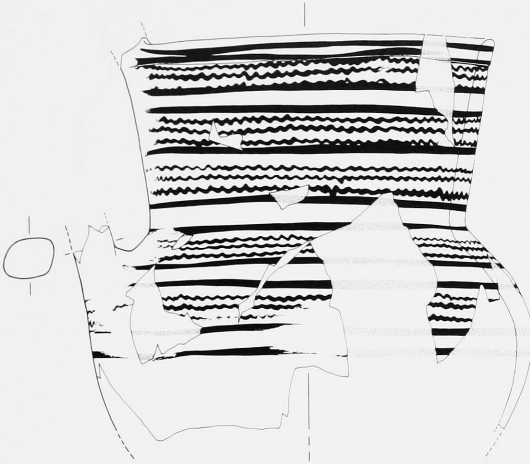

FIGURE 24

LARGE ROUND-MOUTHED JUGS

Destruction Level



632

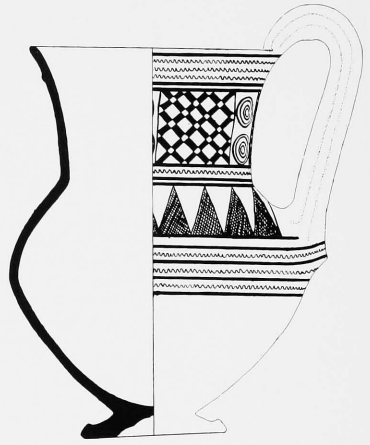

638

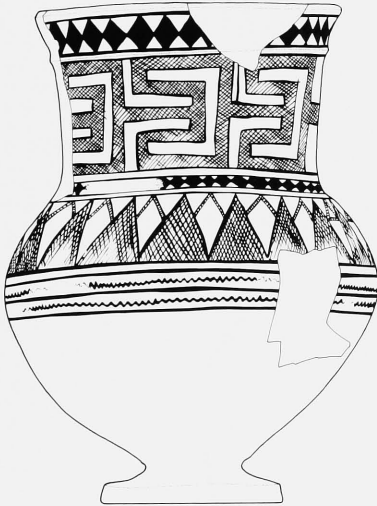

640

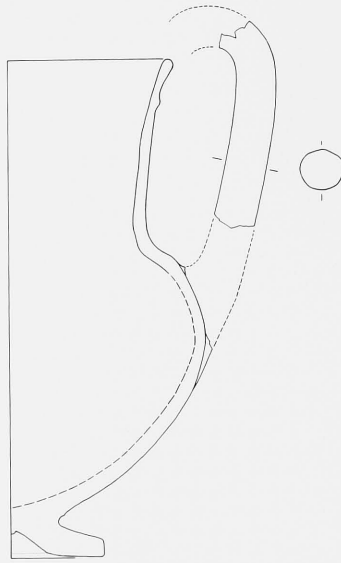

Destruction Level (continued)

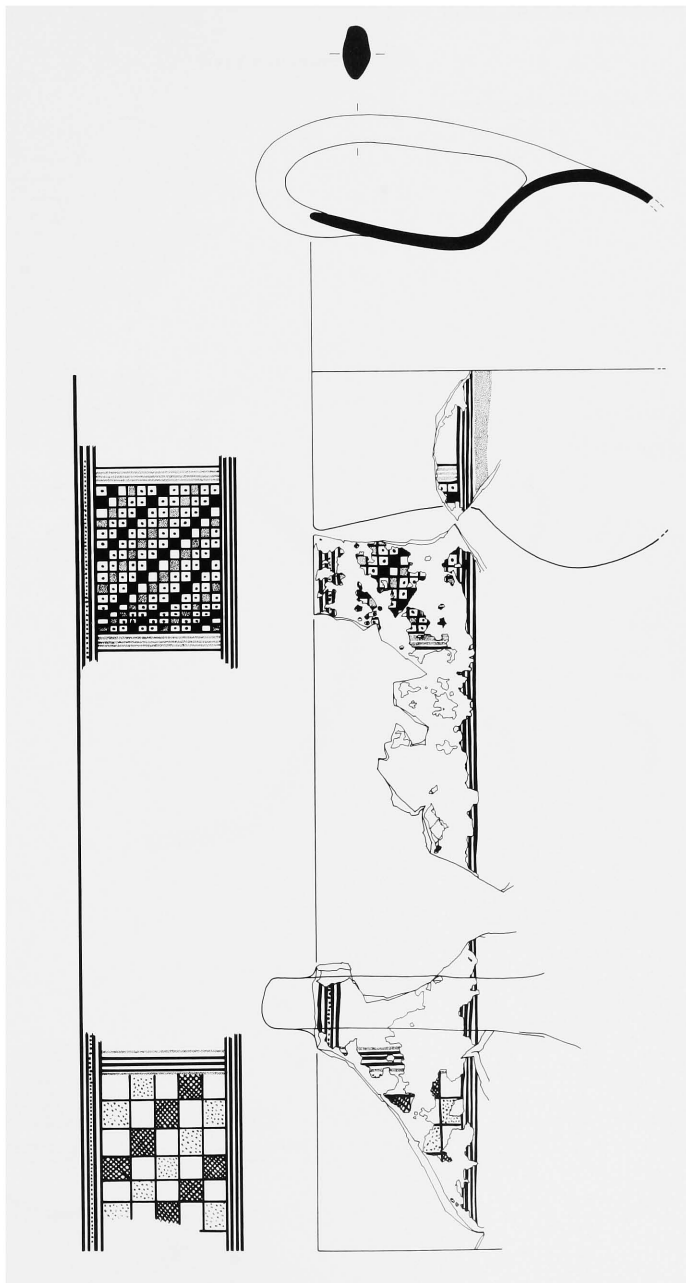

NARROW-NECKED TREFOIL JUGS

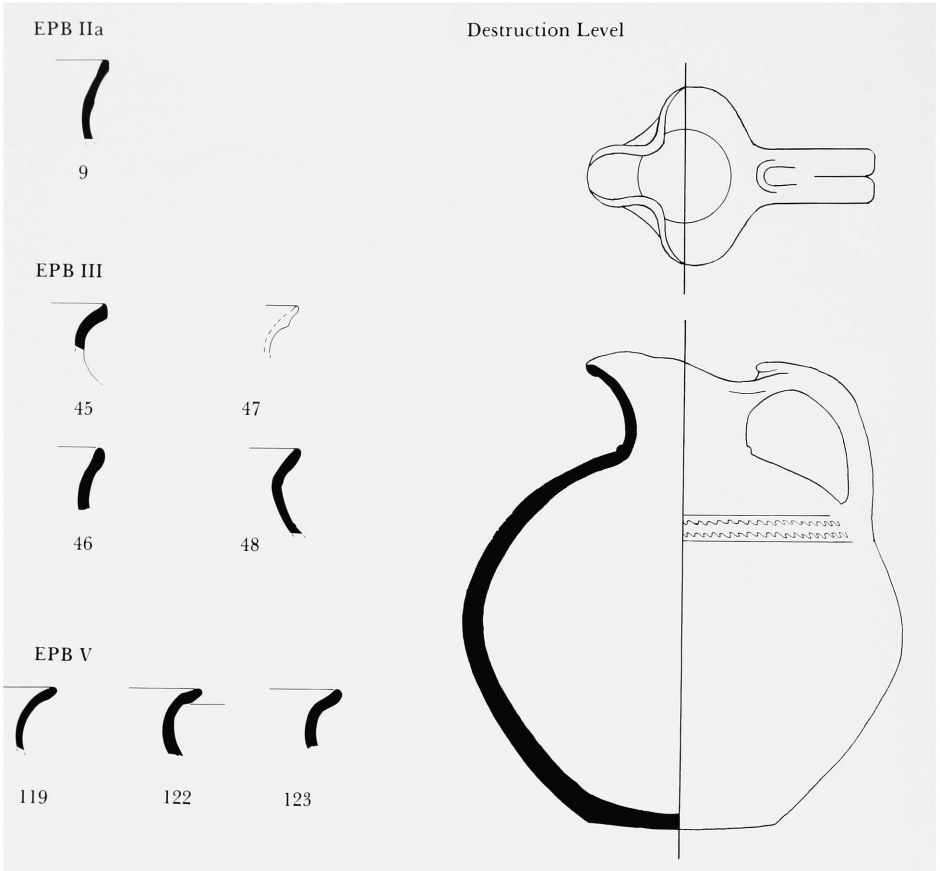

WIDE-MOUTHED TREFOIL JUGS

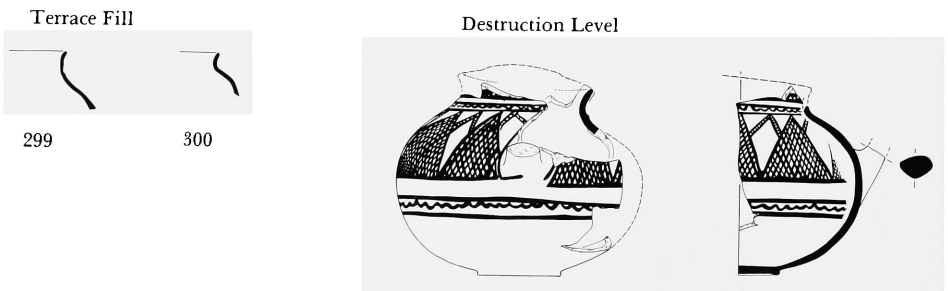

EPB V

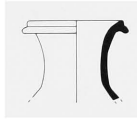

125

Destruction Level

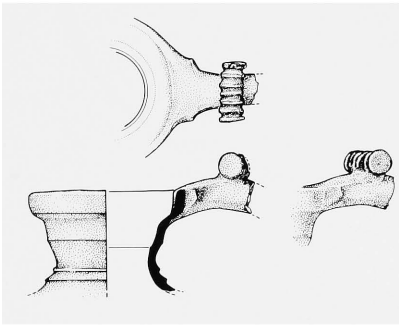

784

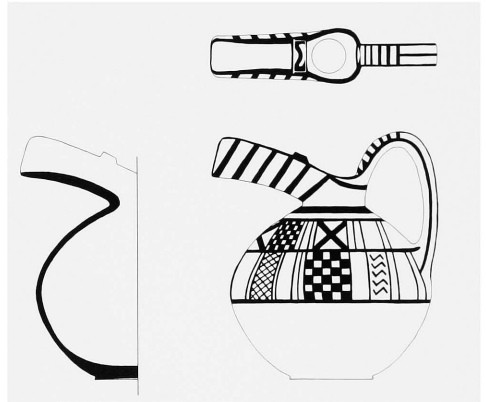

789

Askos

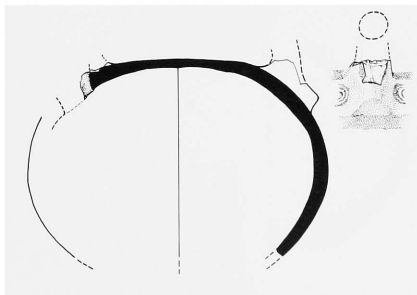

815

Destruction Level

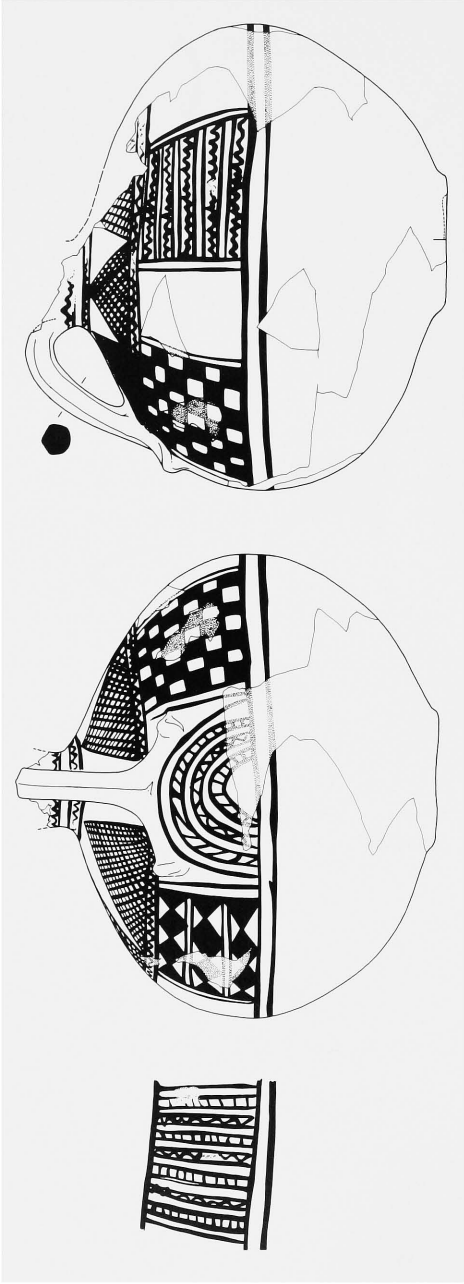

803

13

Destruction Level (continued)

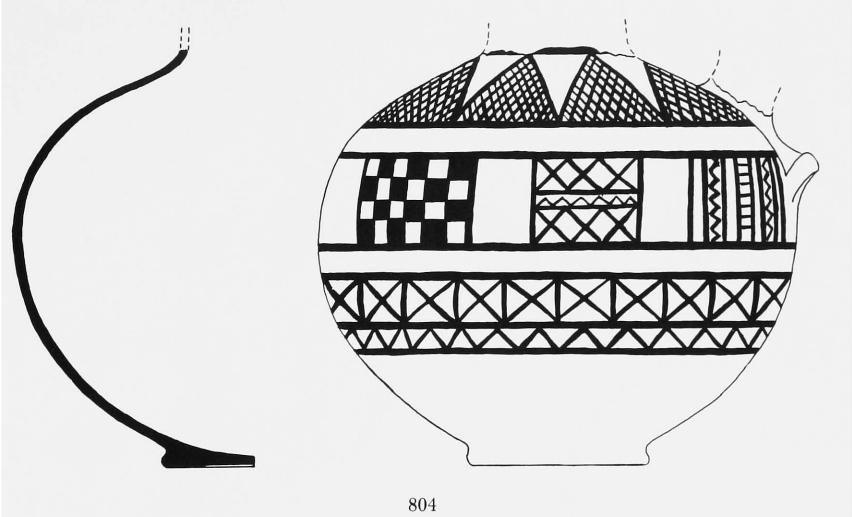

804

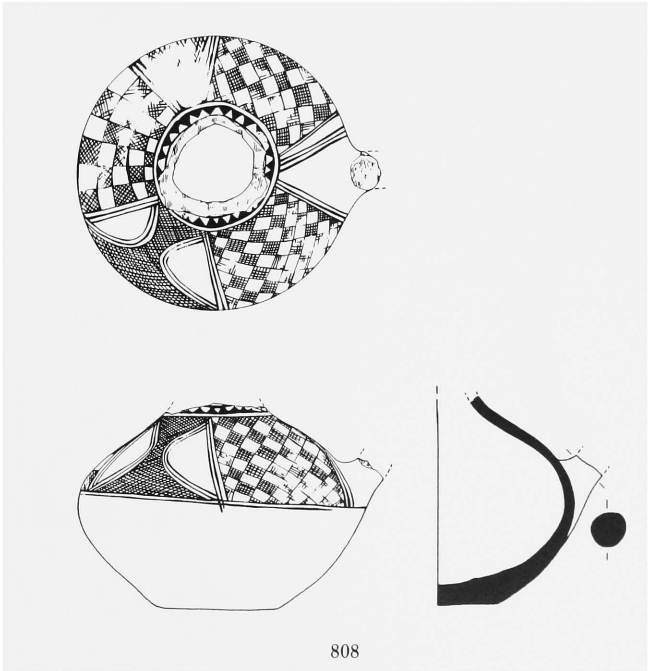

808

Post-Destruction Contexts

Jug Restored with Trefoil Mouth

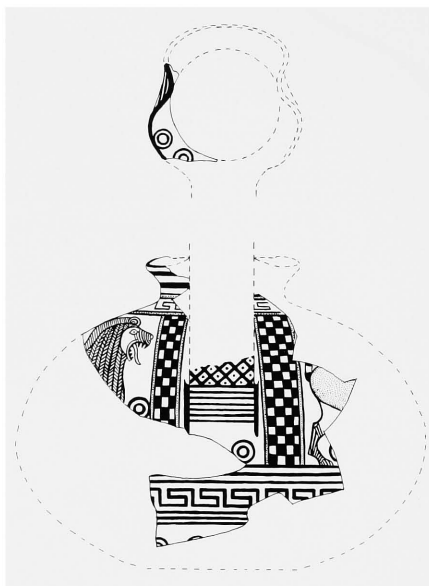
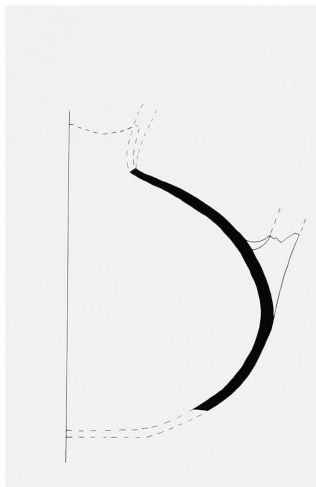

1041

SIDE-SPOUTED SIEVE JUGS

EPB V

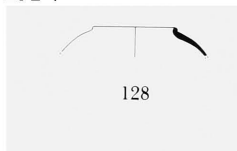

128

Tumulus X

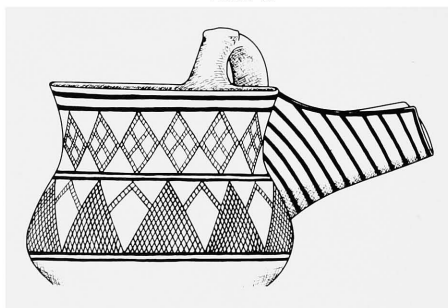

P3136

ONE-HANDLED UTILITY POTS

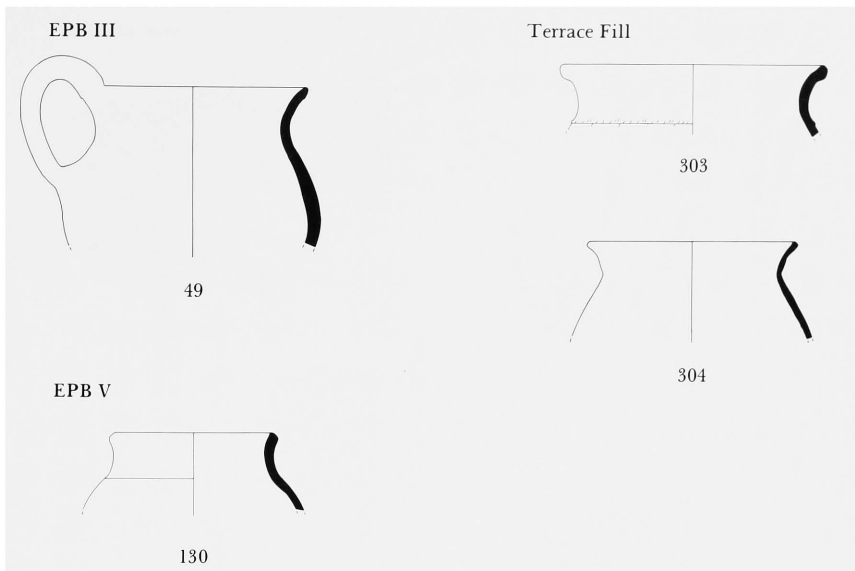

STAND

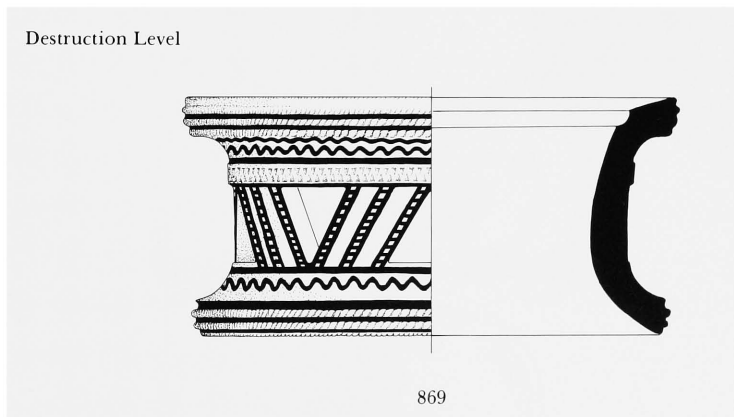

Destruction Level

Rhyton



858

Sipping Chalice

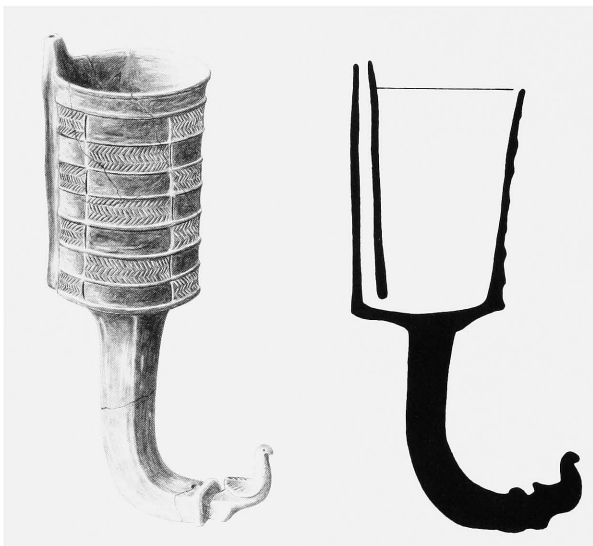

859

Destruction Level (continued)

Sipping Bowl

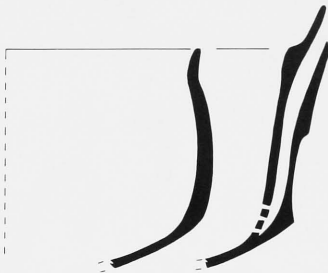
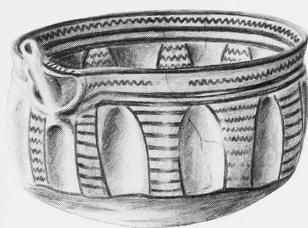

860

Bowl with Perforated Cover



862

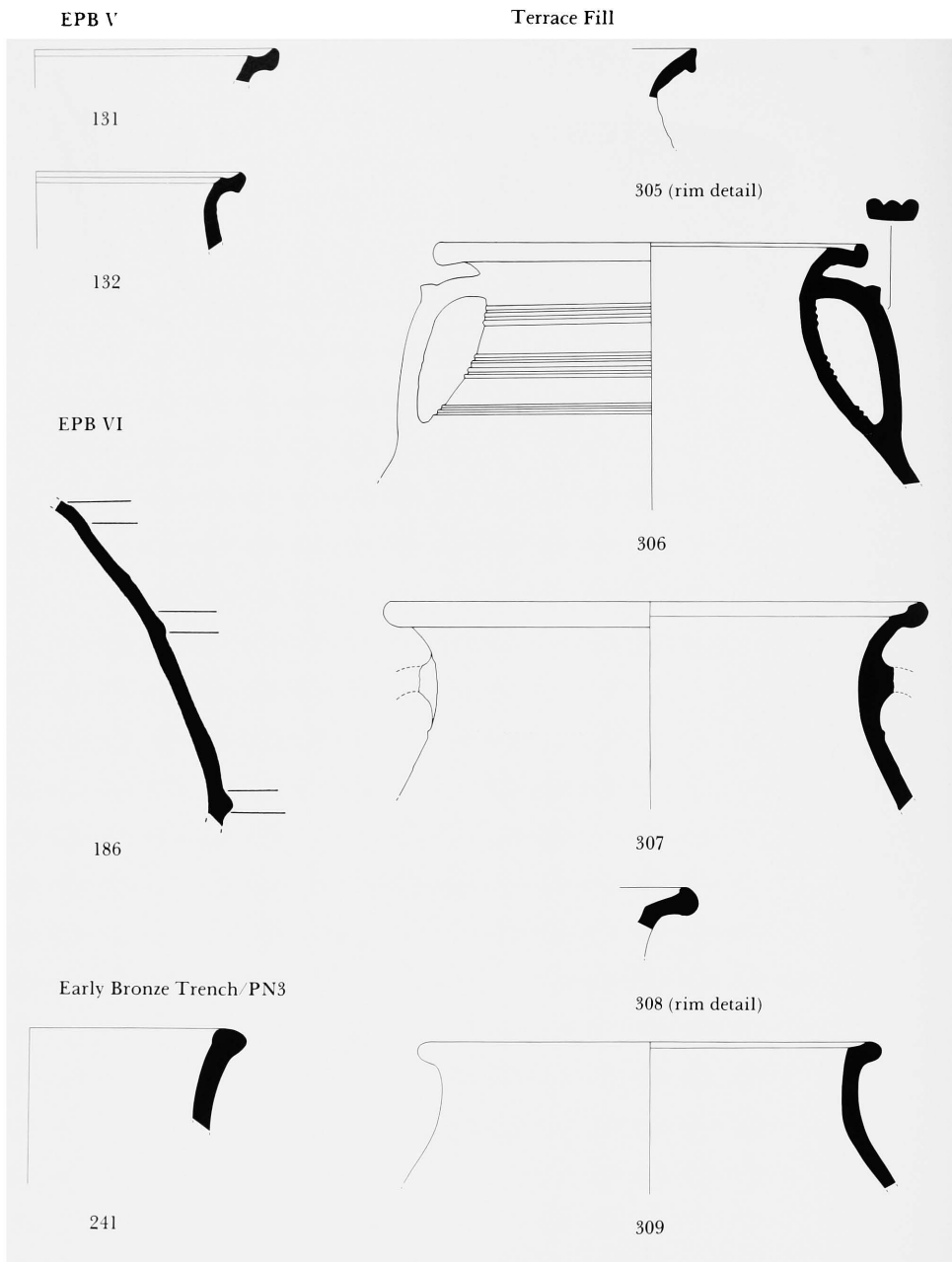

Terrace Fill (continued)



310



314



315



316

Destruction Level

Kantharos Krater

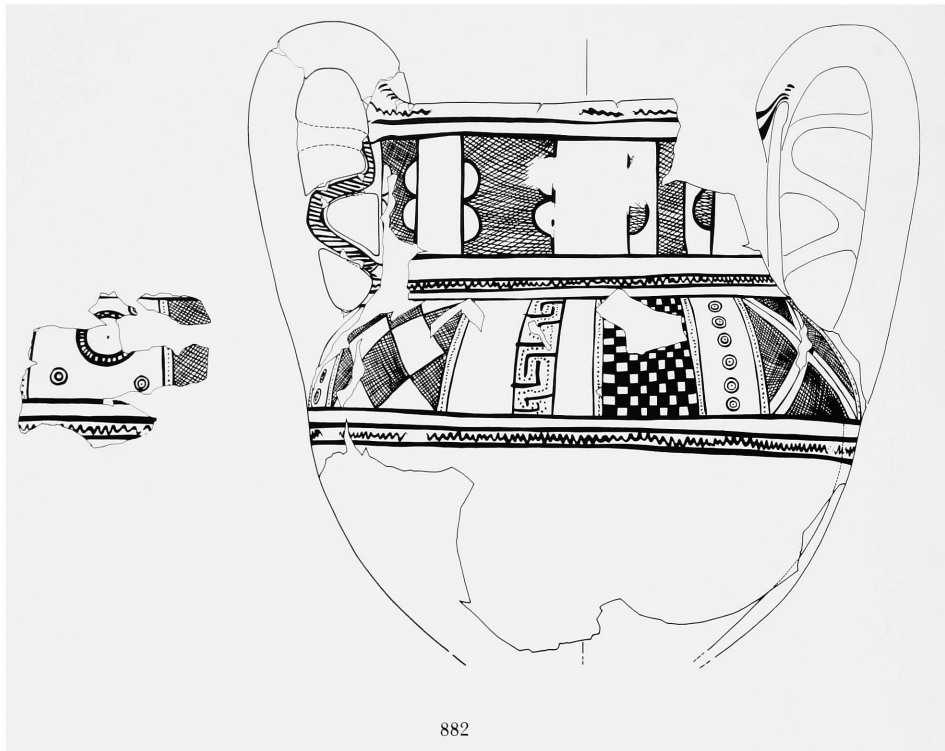

Destruction Level
Shoulder-Handled Amphora

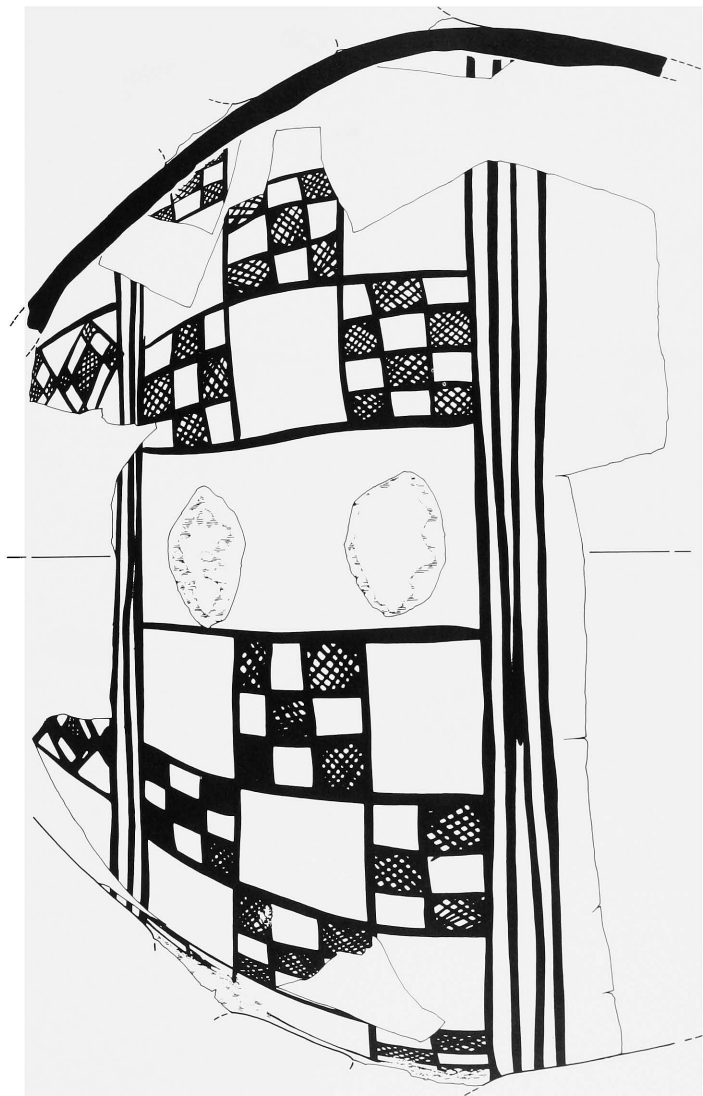

898

1:1

Destruction Level

NARROW-NECKED AMPHORAS, NECK-HANDLED, RIM DETAILS



NARROW-NECKED AMPHORAS, SHOULDER-HANDLED, RIM DETAILS

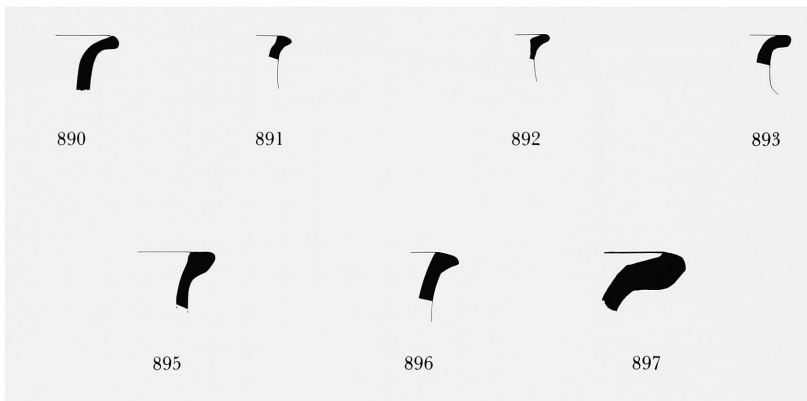

Destruction Level

OPEN-MOUTHED AMPHORAS, RIM DETAILS

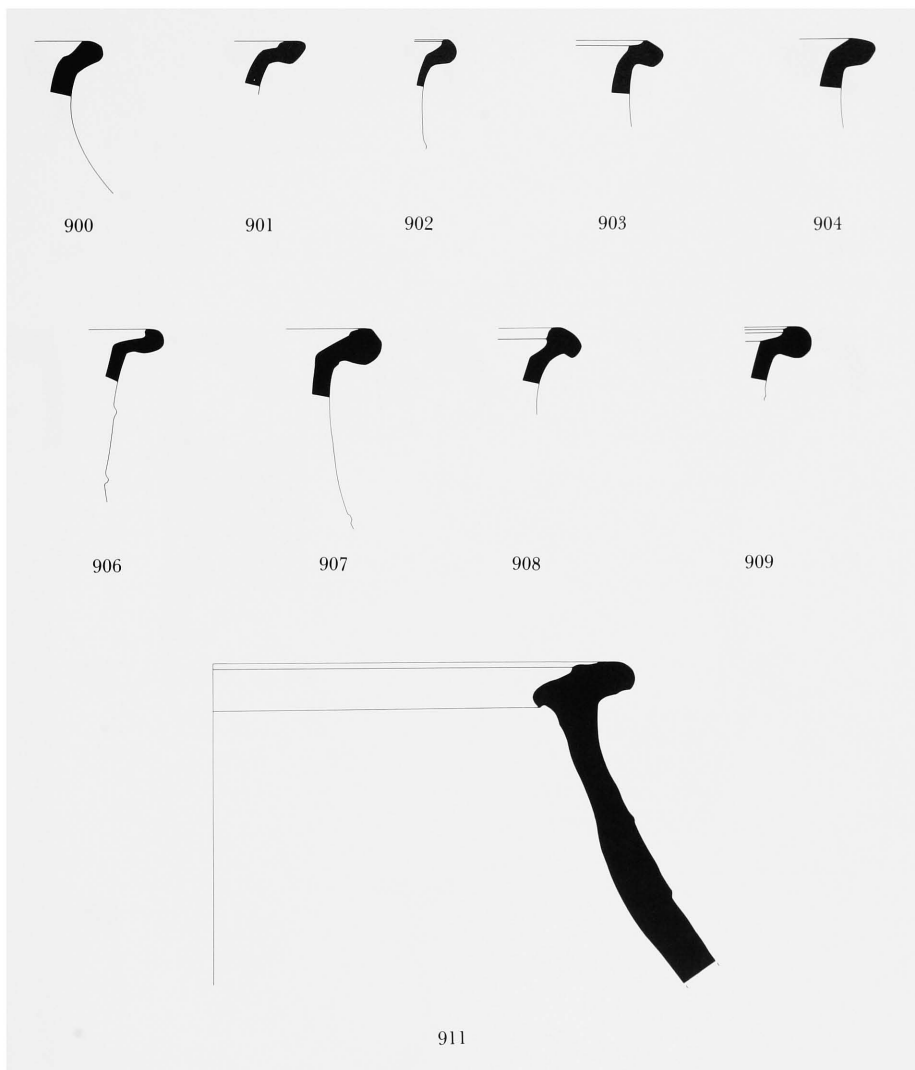

Destruction Level

OPEN-MOUTHED AMPHORAS, RIM DETAILS (continued)

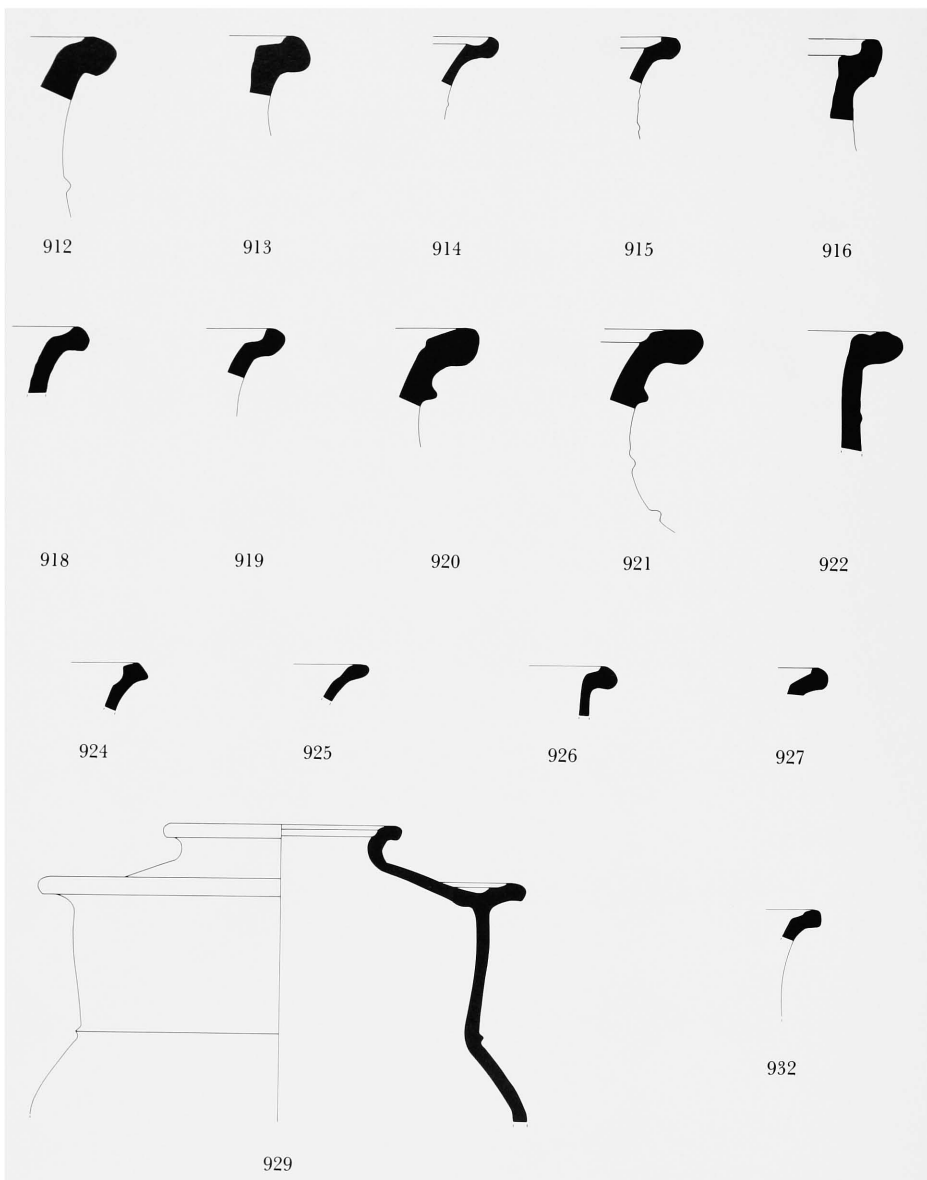

Destruction Level

OPEN-MOUTHED AMPHORAS (PAINTED) (continued)

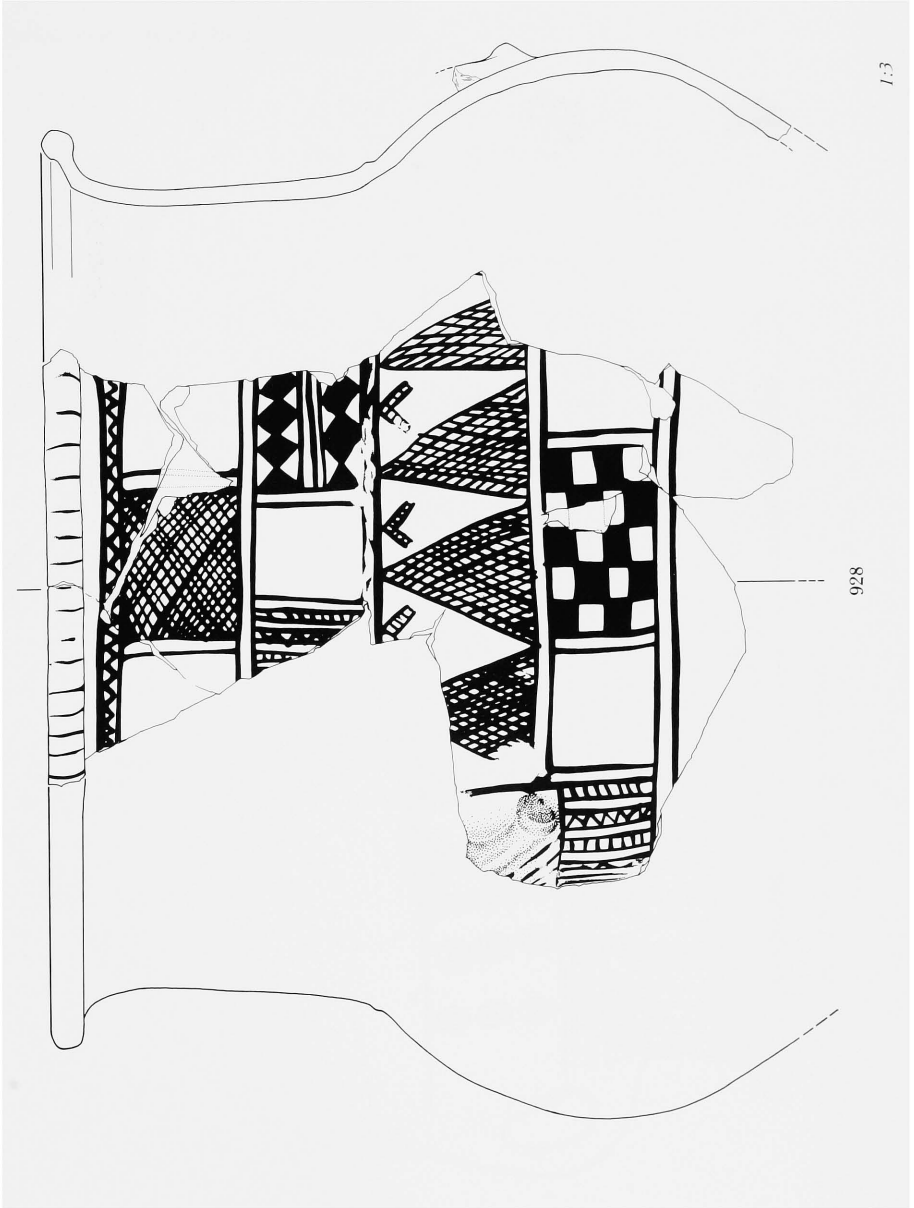

928

Destruction Level

OPEN-MOUTHED AMPHORAS (PAINTED) (continued)

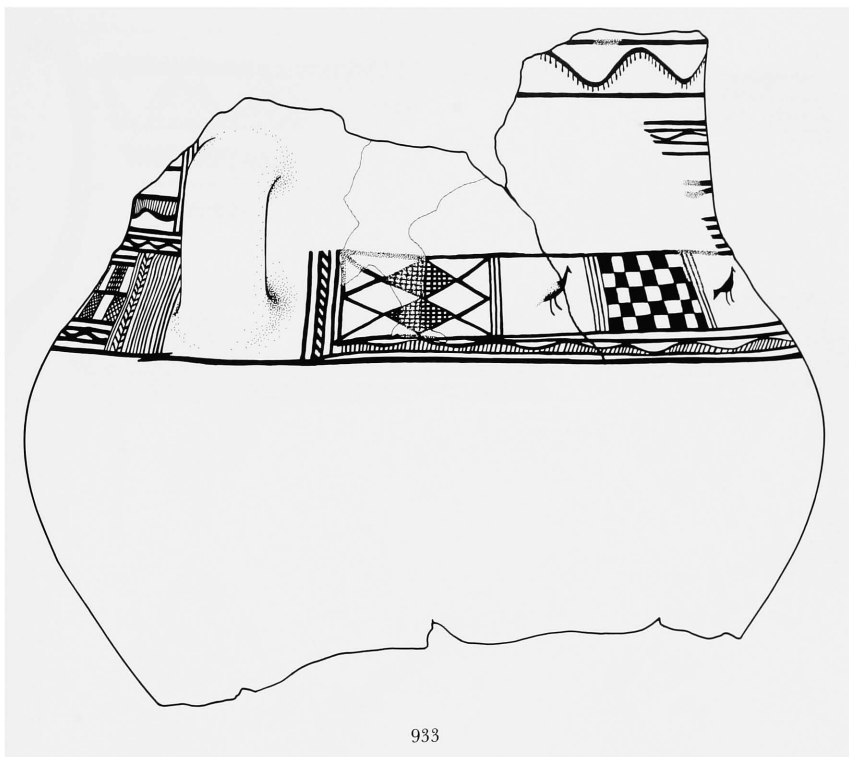

Destruction Level

OPEN-MOUTHED AMPHORAS (PAINTED) (continued)

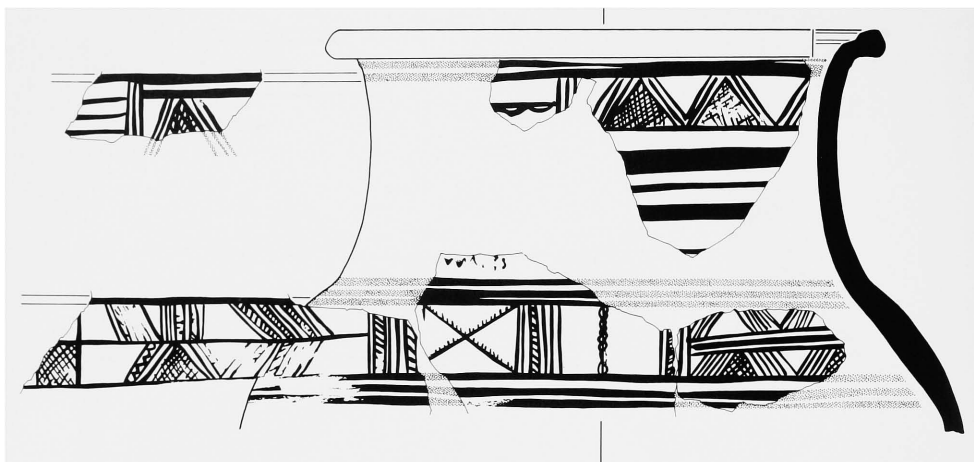

935

MISCELLANEOUS AMPHORA



937

Post-Destruction Contexts

ENORMOUS KRATERS IN STYLE OF BROWN-ON-BUFF

Composite Drawing of 1065, 1066, 1070, 1071, 1072

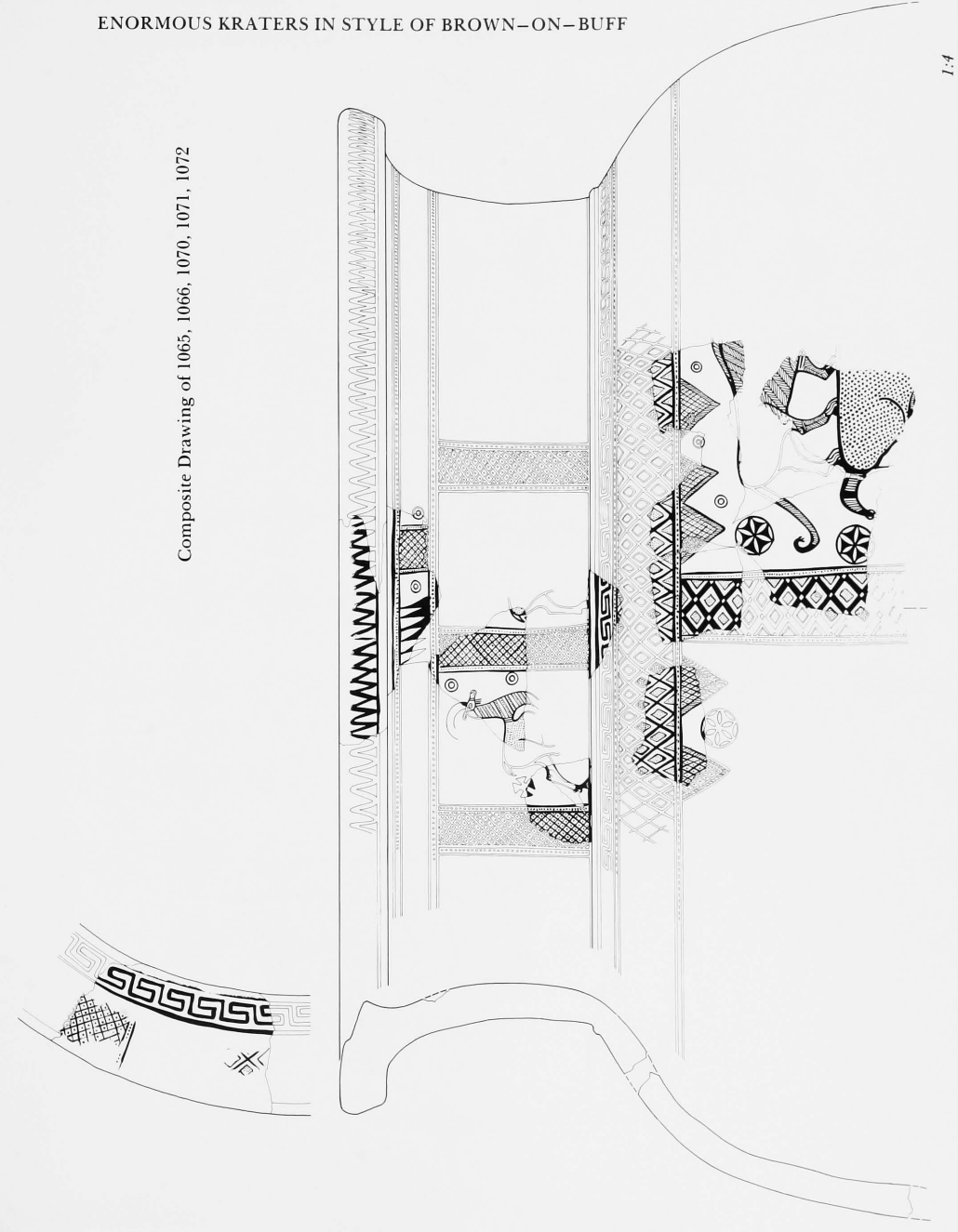

1:4

Post-Destruction Contexts

ENORMOUS KRATERS IN STYLE OF BROWN-ON-BUFF (continued)

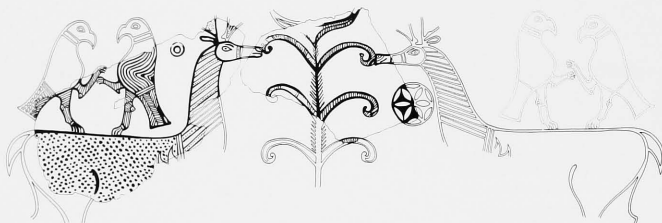

1067

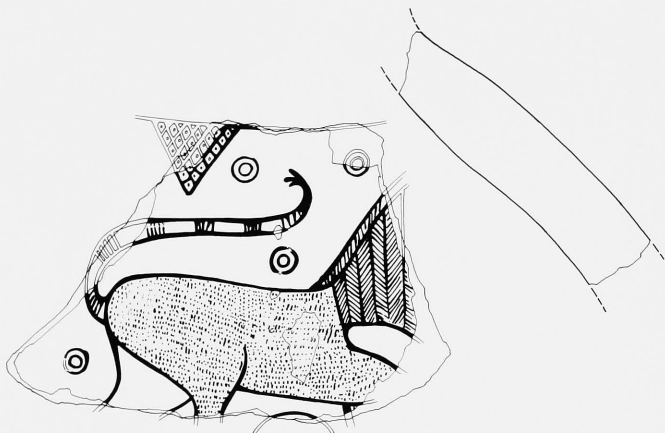

1068

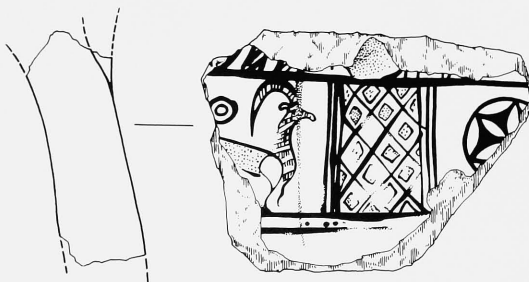

1069

Post-Destruction Contexts

ENORMOUS KRATERS IN STYLE OF BROWN-ON-BUFF (continued)

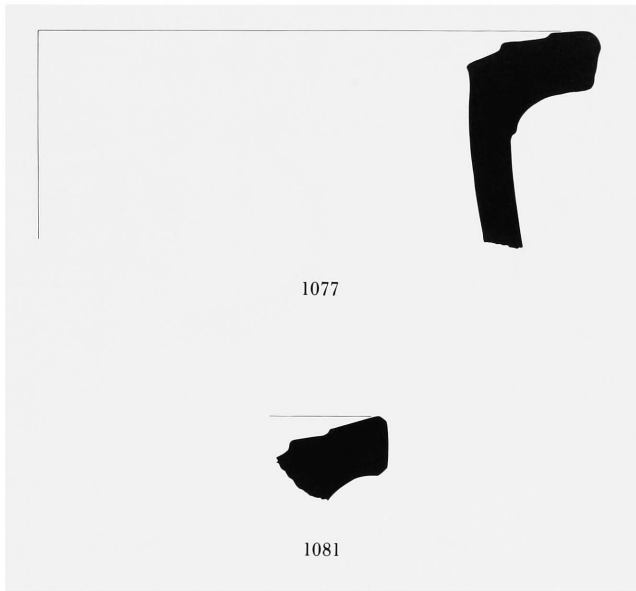

AMPHORA IN THE ALIŞAR IV STYLE

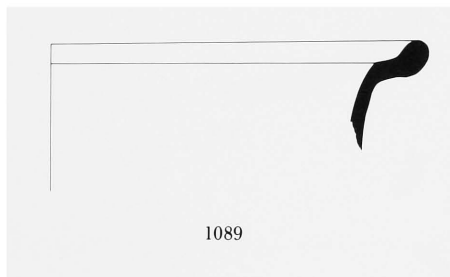

LOW-NECKED JARS AND DINOI

SMALL

Destruction Level

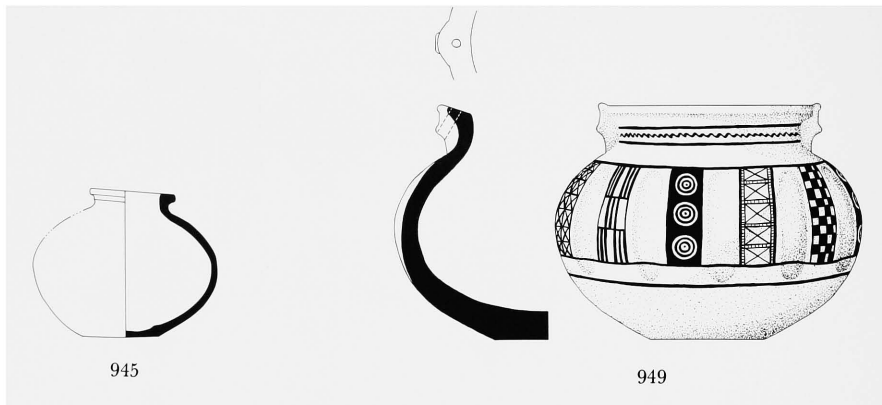

LARGE

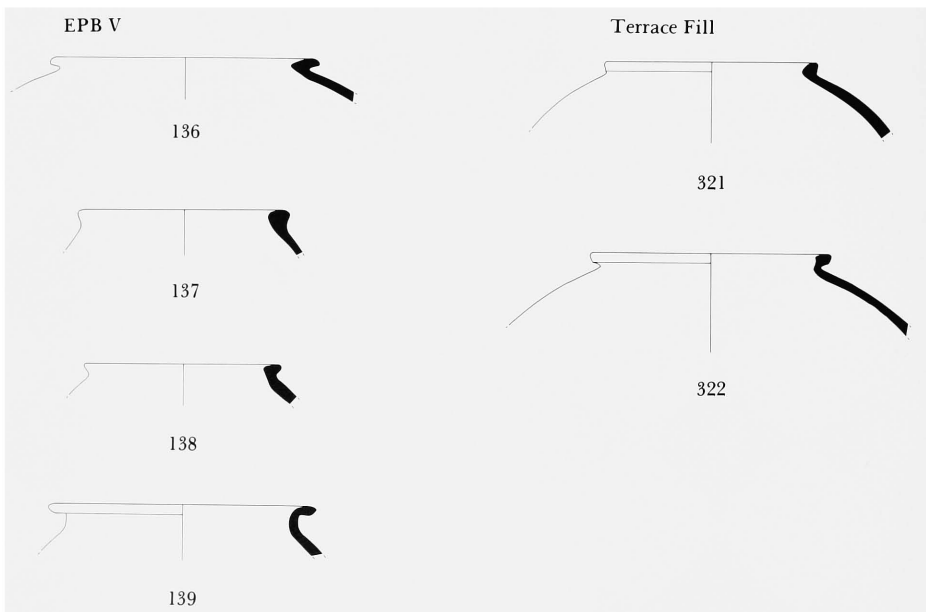

LOW-NECKED JARS AND DINOI

LARGE (continued)

Destruction Level

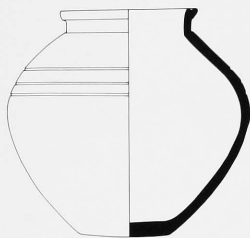

954

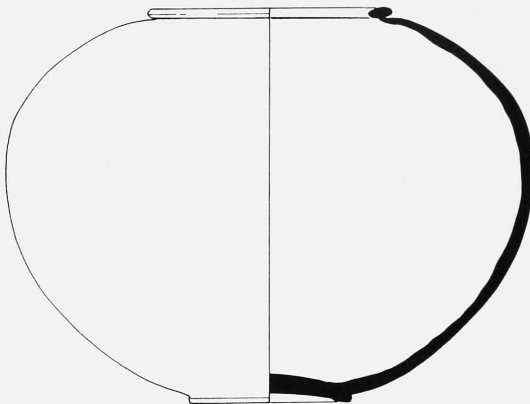

960

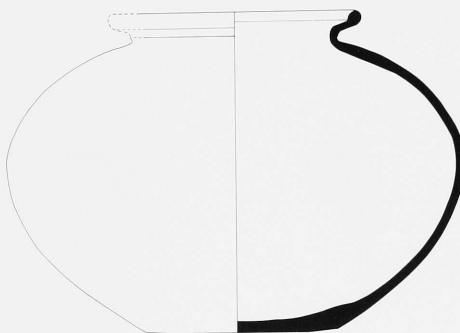

961



970

NARROW-NECKED STORAGE JARS, RIM DETAILS

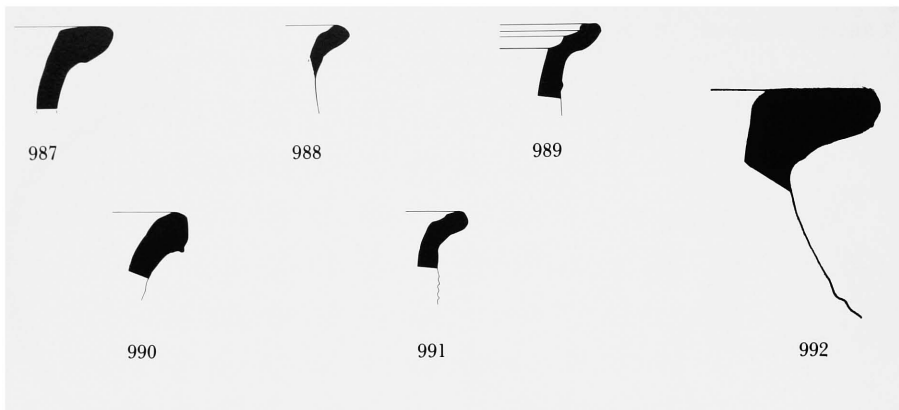

WIDE-MOUTHED STORAGE JARS, RIM DETAILS

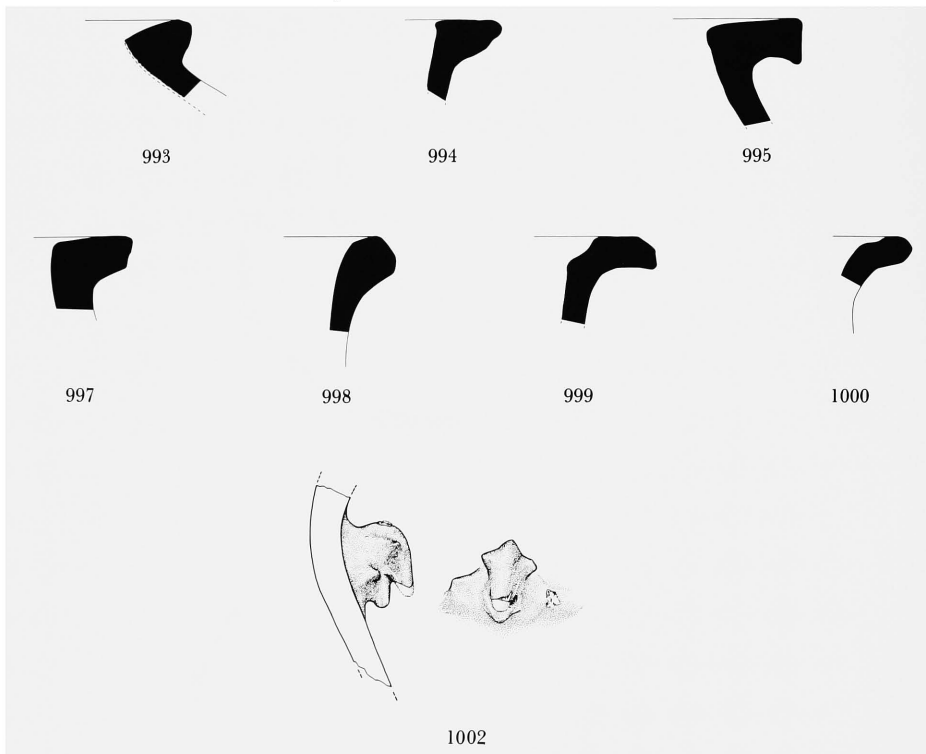

LARGE VESSELS WITH LEDGED RIMS

FIGURE 51

EPB IIb

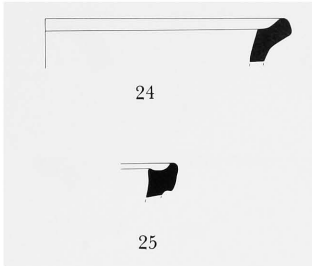

EPB III

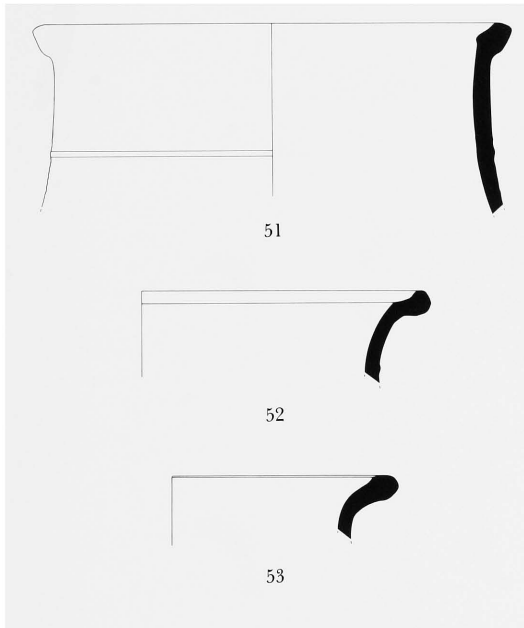

EPB V

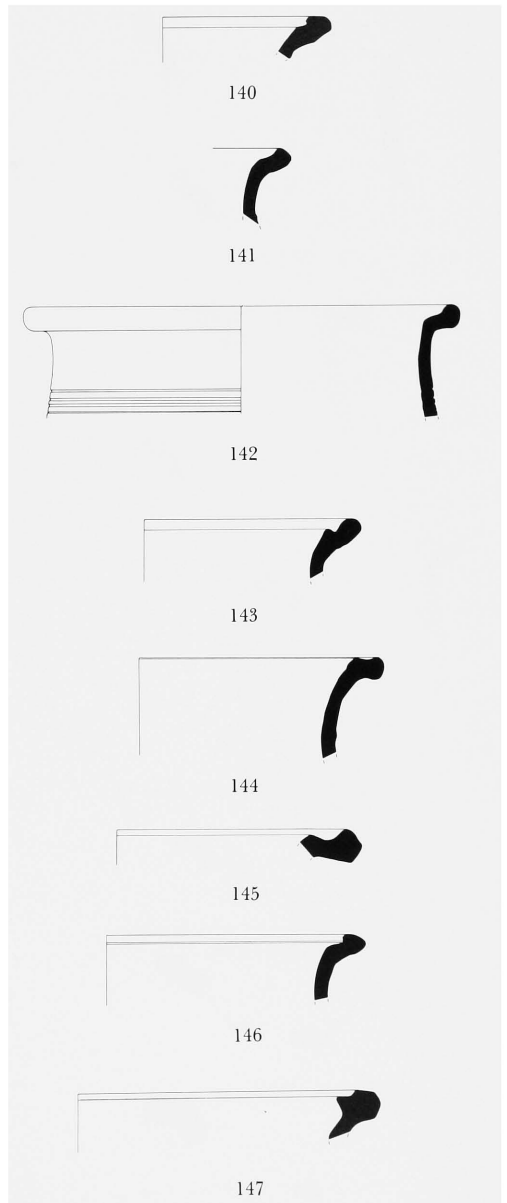
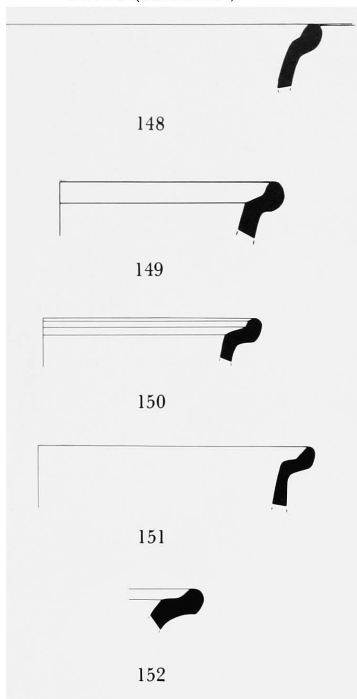

FIGURE 52

EPB V (continued)



LARGE VESSELS WITH LEDGED RIMS

Meg. 10, Layer 1 (continued)

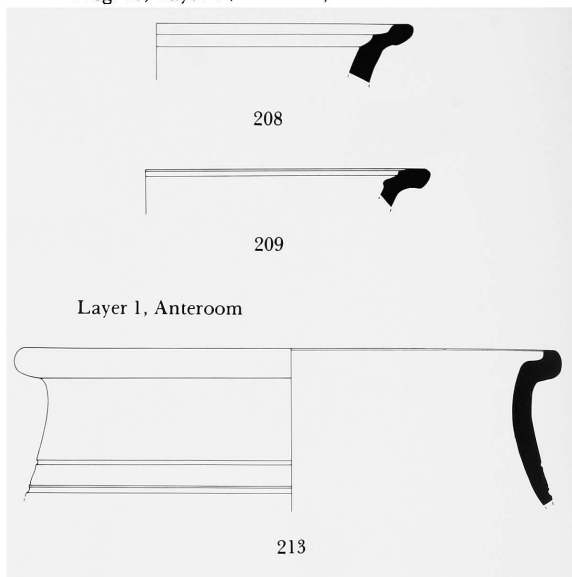

Layer 1, Anteroom

NCT IVb

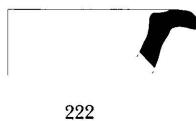

Meg. 10, Layer 1

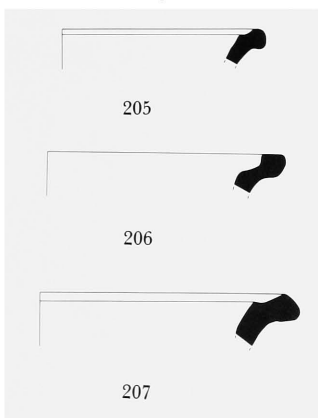

Early Bronze Trench/PN 3

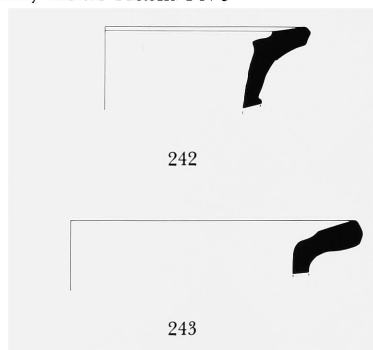

LARGE VESSELS WITH LEDGED RIMS

FIGURE 53

Meg. 5, Under Floor



Terrace Fill

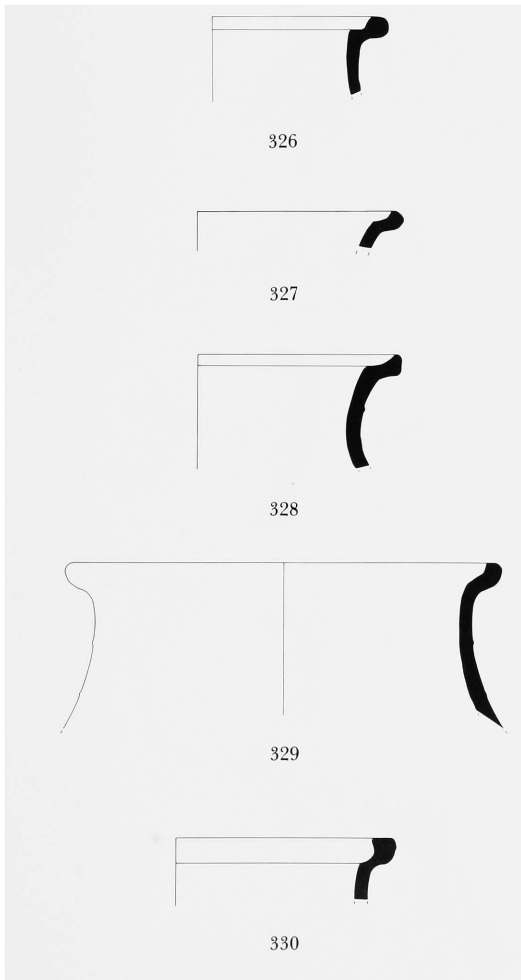

Terrace Fill (continued)

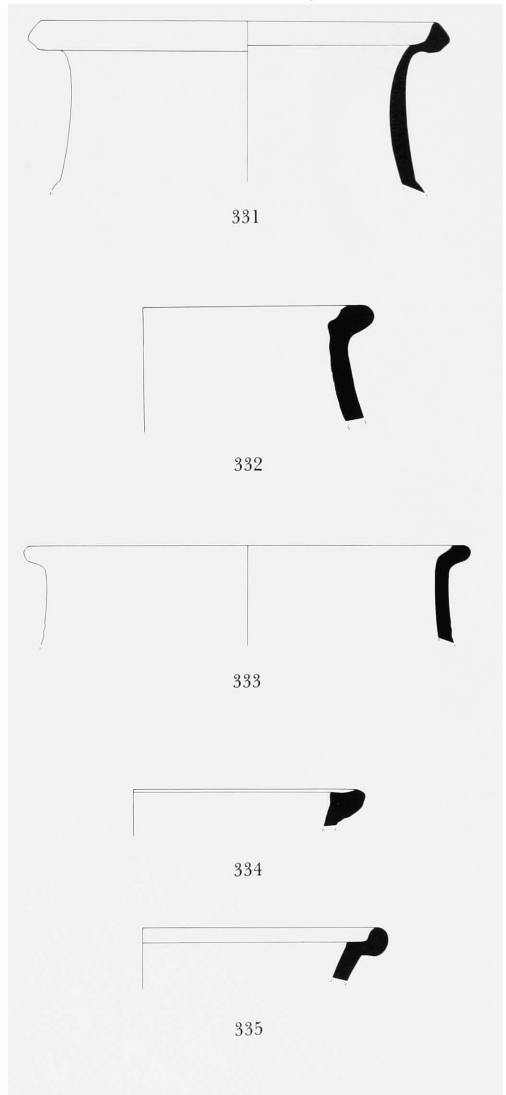

Terrace Fill (continued)

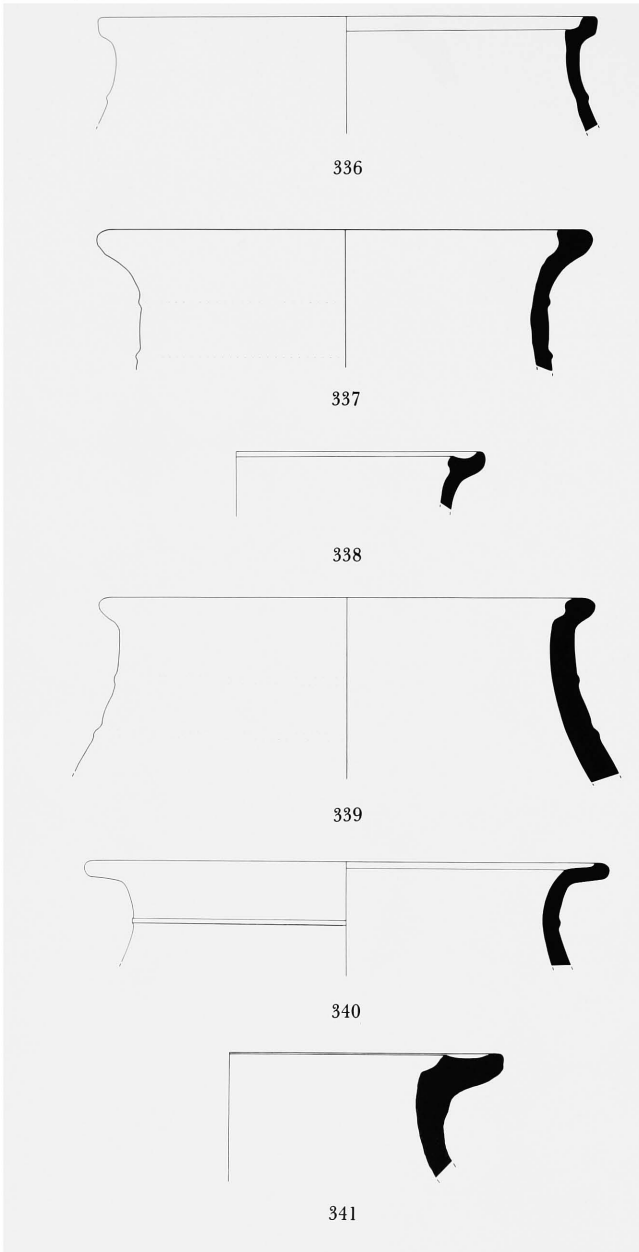

Terrace Fill (continued)

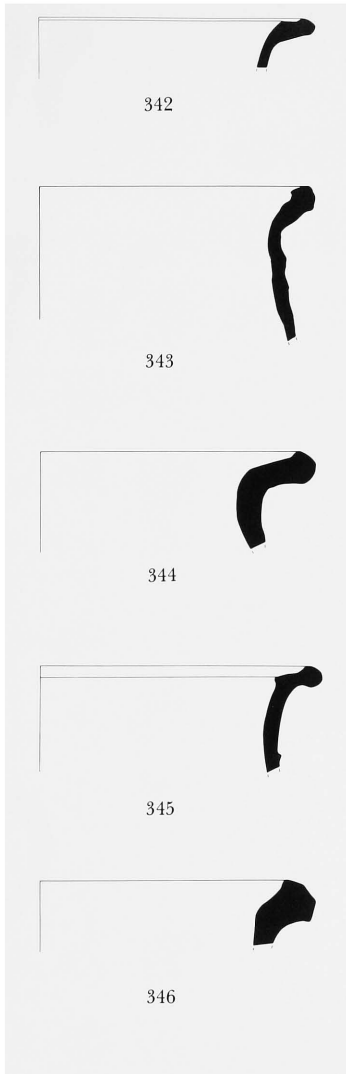

Terrace Fill (continued)

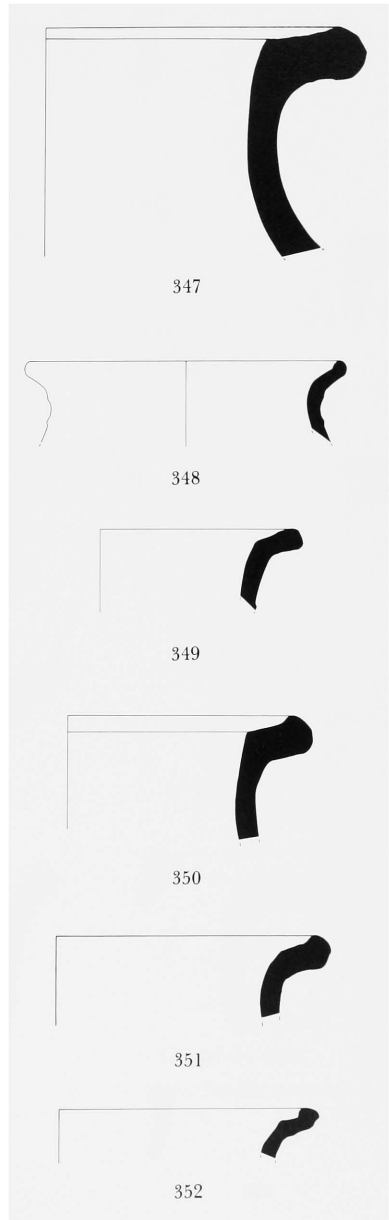
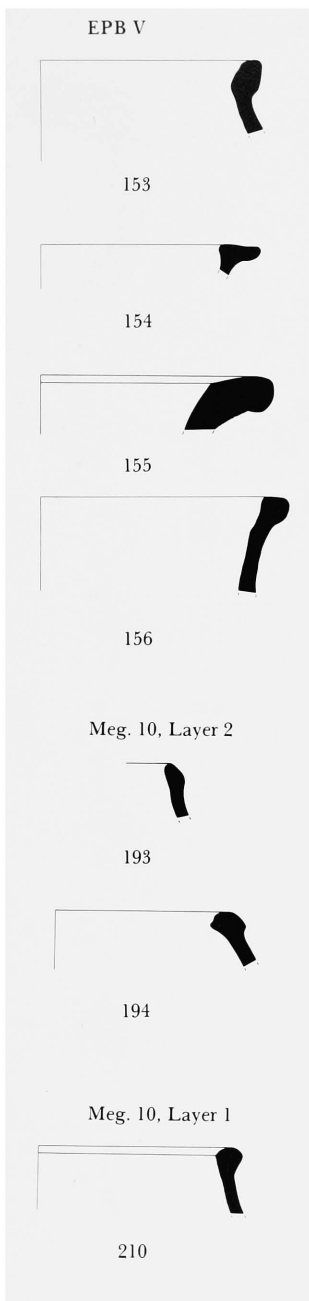
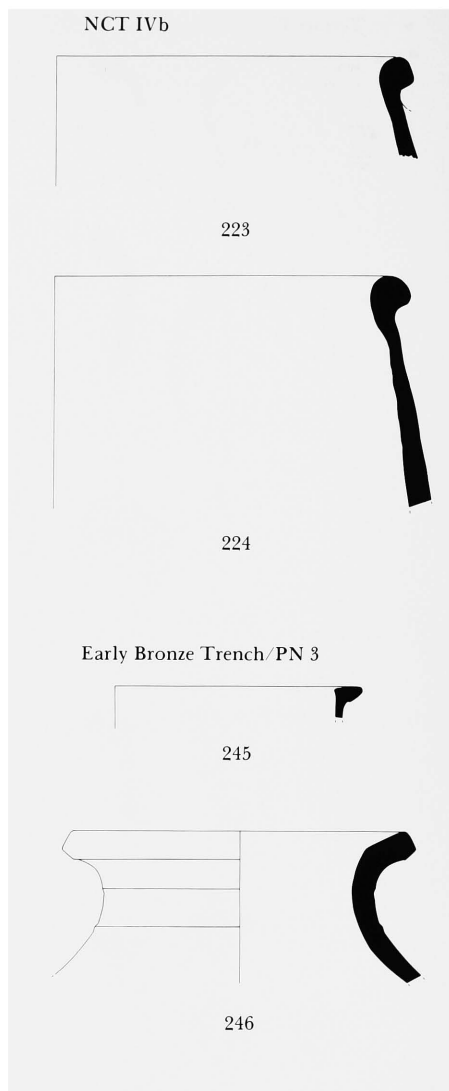

FIGURE 56



LARGE VESSELS WITH NON-LEDGED RIMS



Terrace Fill



353

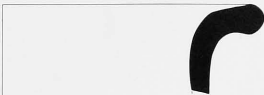

359



364



354

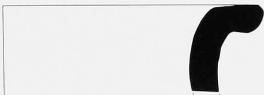

360

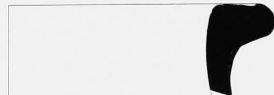

365

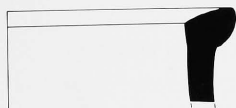

355

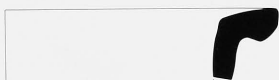

361

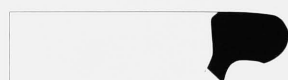

366



356



362

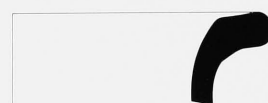

367

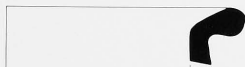

357



363



368



358

FIGURE 58

AMBIGUOUS VESSELS, MISCELLANEOUS

EPB IIb



27

EPB V



157



158

EPB III



54



159



55



160

Meg. 10, Layer 1



211



56



165

NCT IV b



225



57

Meg. 10, Layer 4



188

Terrace Fill



377

Destruction Level

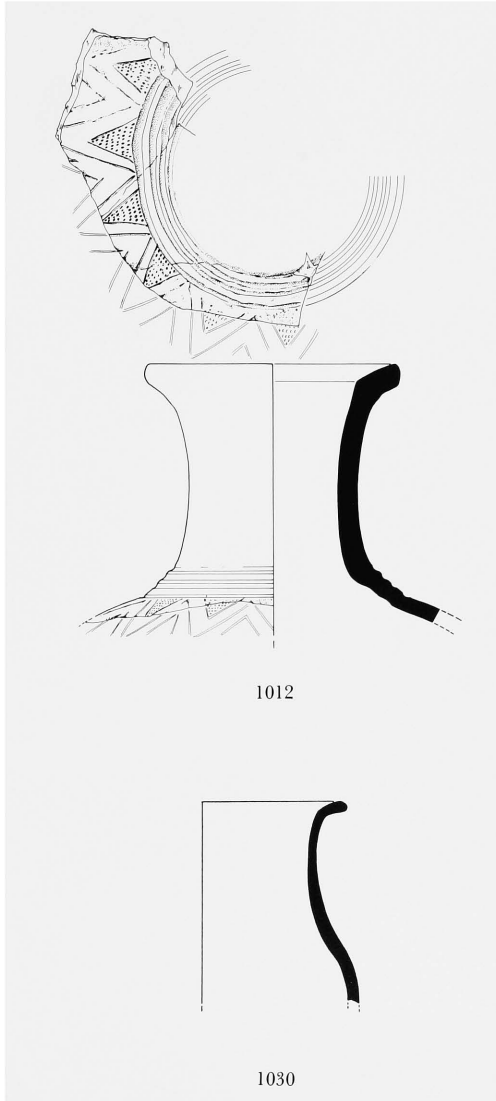

Diminishing Triangles



1009

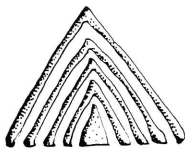

918



P1740

Circular Stamps

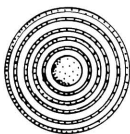

992



404

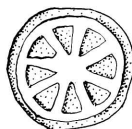

1014



1003

X Panel Stamps



1004



1003



1004

Herringbone Stamps



407

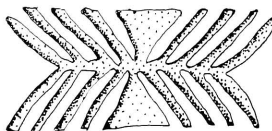

939

Stamp with Semicircles

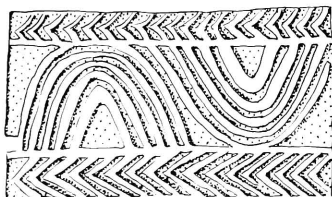

1017 (composite drawing)

Lozenge Stamps

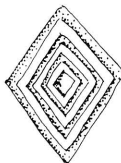

1000

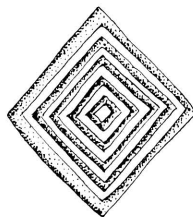

992

S-Spirals



922



1000

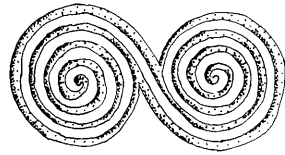

1001



918

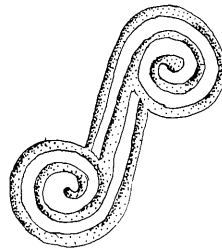

1016

Spectacle-Spiral

S-Curls



1000

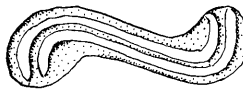

939



1000

Concentric Horseshoes



1000

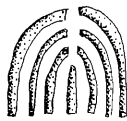

1001

Oval Tree



1003

Goat



1000

TRIANGLES

TYPE 1

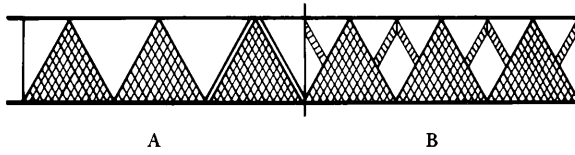

TYPE 2 (Chevron-Triangles)

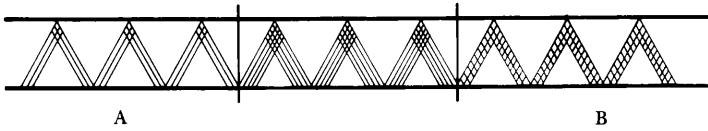

TYPE 3

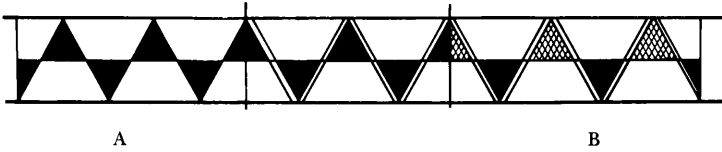

LOZENGE ROWS

SIMPLE

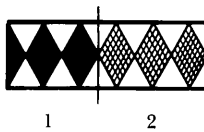

COMPLEX

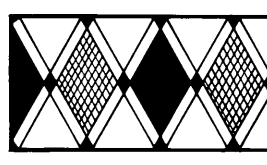

ZIGZAG ROWS

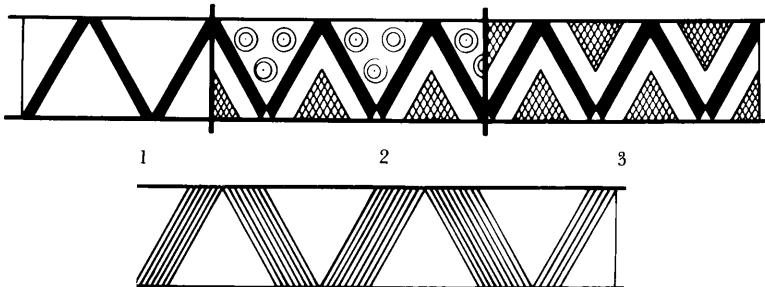

MEANDERS

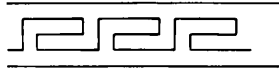

1

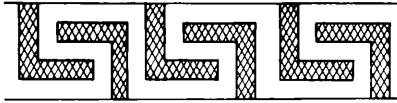

2



3A

3B

CROSS-AND-LOZENGE PANELS

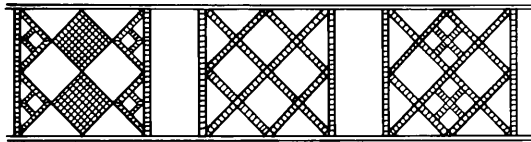

1

2

3

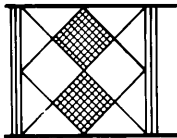

4

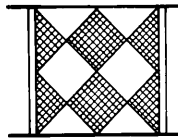

5

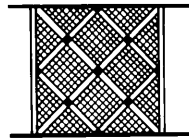

6

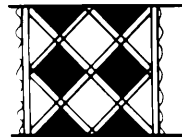
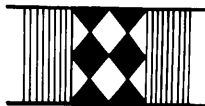

7

MULTIPLE LOZENGE PANEL

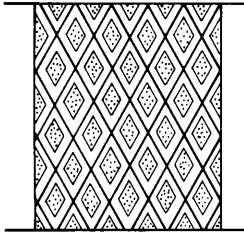

1

CHECKERBOARDS

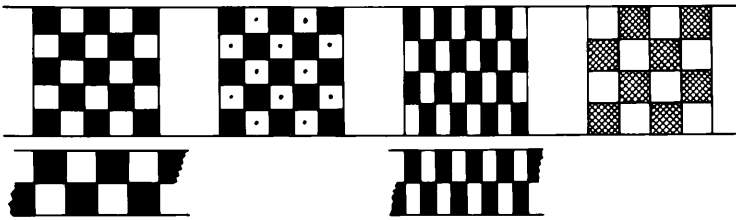

1A

1B

1C

2

OBLIQUE CHECKERBOARD

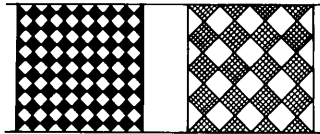

1

2

LATTICED PANELS

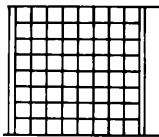

1

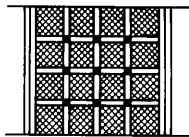

2

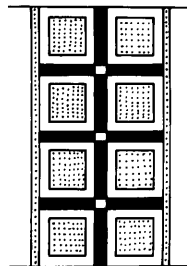

3

CROSS—HATCHING

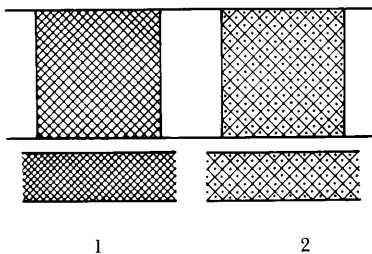

HERRINGBONE

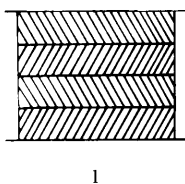

SEMICIRCLE PANELS

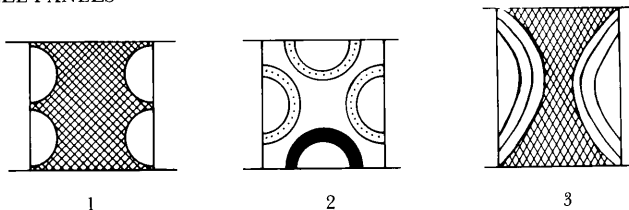

BUTTERFLY PANEL

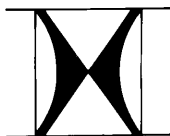

VERTICAL LADDERS AND ZIGZAGS

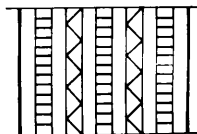

MALTESE CROSS



FEATHER TREE



Plates



A. Storerooms behind Meg. 1, from NW.

PLATE B



B1. Meg. 4, E corner.



B2. CC 2, E corner.



C. TB 2, NW aisle.

PLATE D



D1. Pottery depot beside Terrace Gateway (South Phrygian House), trefoil jugs and bowls.



D2. Pottery depot as above, piles of bowls.



E1. Pottery depot, as above, inverted carinated bowl with underlying bottom of wicker basket.



E2. TB 5, from SW.



F. Area to W of EPB, from E. A) cobbled Floor 2; B) Floor 3; C) Floor 4; D) latrine pit; E) EPB SW Room; F) EPB threshold; G) Meg. 10, S wall; H) diagonal wall over EPB SW Room (partially removed); I) mudbrick wall belonging to Floor 4; J) window cut beside Meg. 10.



G. Meg. 10 sounding, from E. Main room being cleared to Floor 3; hearths and earlier mudbrick bin still in place; anteroom not yet dug. Note at L the merger of the cobbled Floor 2 and Floor 3 in front of the EPB.

PLATE H



H. Aerial view of City Mound.

CARINATED BOWLS

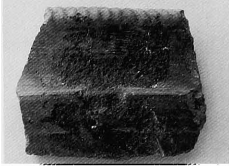

6 (EPB II a)



61 (EPB V)



177 (EPB V)

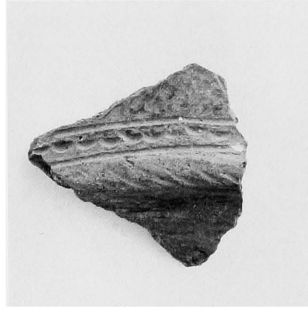

237 (PN 3)



251 (Terrace Fill)

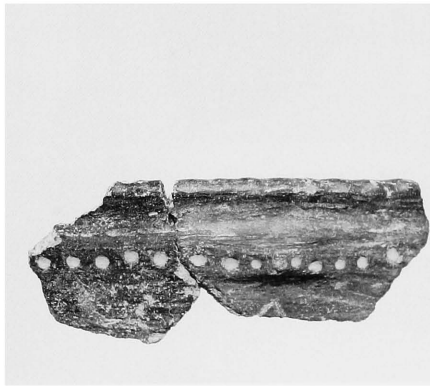

252 (Terrace Fill)

PLAIN BOWLS



62 (EPB V)

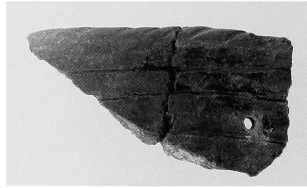

63 (EPB V)



64 (EPB V)



190 (Meg. 10-2)



226 (NCT IV a)

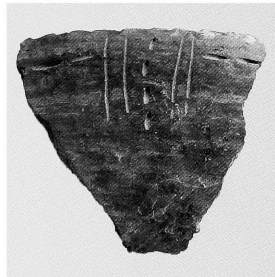

238 (PN 3)

UNCLASSIFIABLE BOWL



227 (NCT IV a)

LOOP-HANDLED CUP

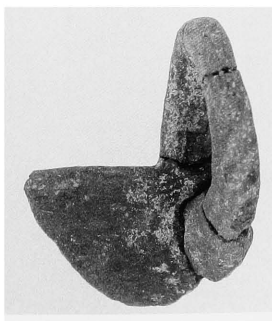

215 (NCT IV b)

CLOSED VESSELS, GROUP 1



1 (EPB I)

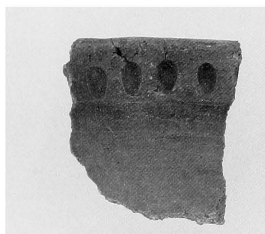

11 (EPB II b)



67 (EPB V)



217 (NCT IV b)



219 (NCT IV b)

CLOSED VESSELS, GROUP 2

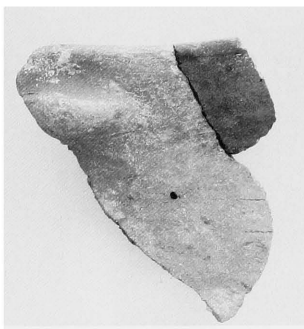

2 (EPB I)



3 (EPB I)

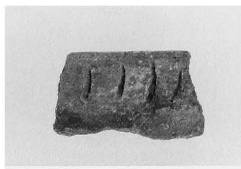

4 (EPB I)



12 (EPB II b)

PLATE 6

CLOSED VESSELS, GROUP 2 (cont.)



13 (EPB II b)

EARLY PHRYGIAN HANDMADE

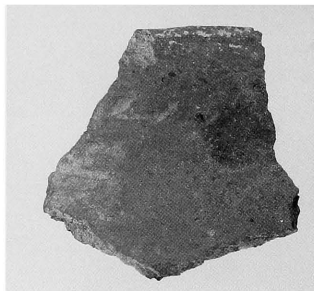

68 (EPB V)



253 (Terrace Fill)



400 (M4 I)



229 (NCT IV a)

CLOSED VESSELS, AMBIGUOUS



69 (EPB V)



70 (EPB V)

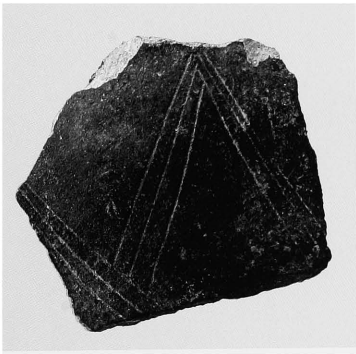

191 (Meg. 10-2)



230 (NCT IV a)

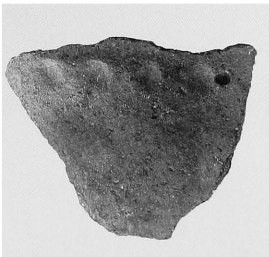

231 (NCT IV a)

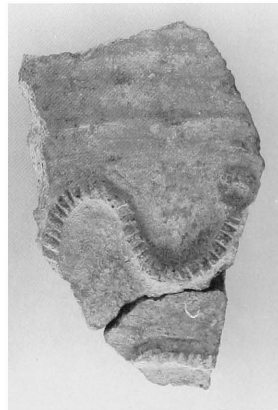

256 (Terrace Fill)

PLATE 8

AMPHORA
Terrace Fill



255

MISCELLANEOUS HANDMADE

CARINATED BASIN
Destruction Level



410

ONE-HANDED UTILITY POTS
Destruction Level



411



412



413

SPOUTED JUGS
Destruction Level



414



415

EPB II b
TREFOIL JUG



14

BOWL
Destruction Level



416

ROUND-MOUTHED JUG
Destruction Level



417

TREFOIL JUG
Destruction Level



418

MUGS

Destruction Level



419



420



421

SIDE-SPOUTED JUG

Destruction Level



422

PINCH-POTS
Destruction Level



423



424



425

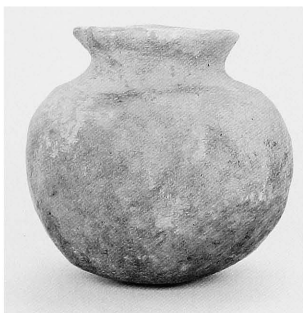

426



427



428

PINCH-POTS

Destruction Level (cont.)



429



430

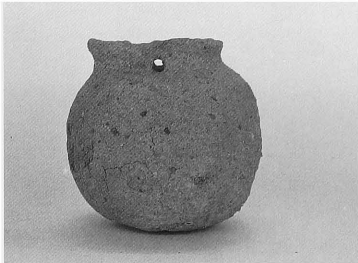

431



432

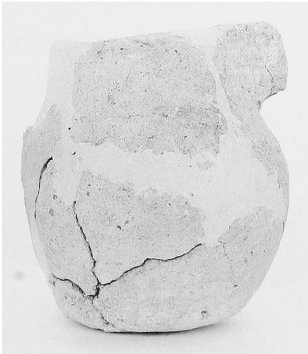

433



434

CLASS 1

Destruction Level



435



436



437



438

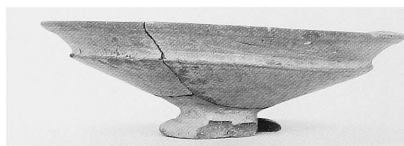

439

CLASS 2
EPB III



34

Meg. 10-1



198

Terrace Fill



265

Destruction Level



440



441

CLASS 2

Destruction Level (cont.)



442



443

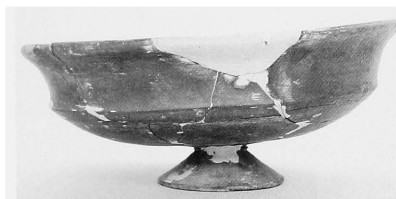

444



445



446



447



448

CLASS 2

Destruction Level (cont.)

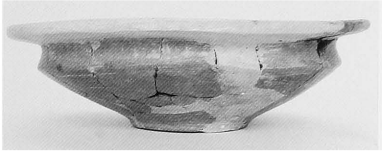

449



450



451



452



453



454



455

CLASS 2

Destruction Level (cont.)



456

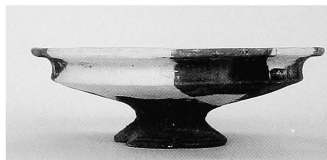

457



458



459



460



461

CLASS 2

Destruction Level (cont.)



462



463



464



465



466



467

CLASS 3
Destruction Level



468



469



470



471

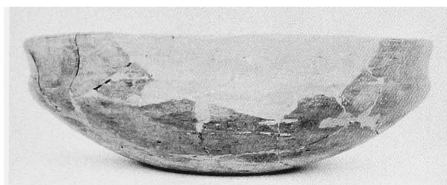

472



473

CLASS 3

Destruction Level (cont.)



474

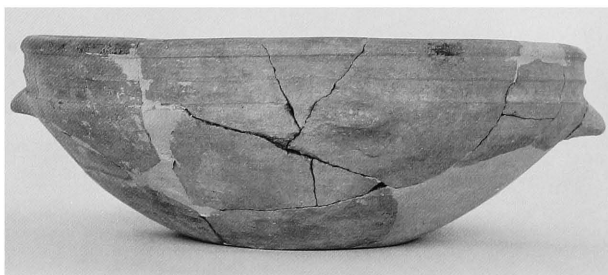

475



476

CLASS 3
Destruction Level (cont.)



477



478



479



480



481

CLASS 3
Destruction Level (cont.)

Incised

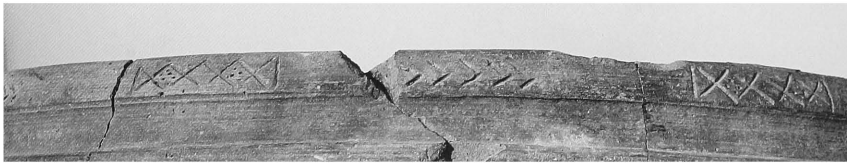

482

UNCLASSIFIED
Destruction Level



483

482 - 1:4
482 Detail - N.S.
483 - 3:8

FLARING-RIMMED BOWLS

EPB V



100

Terrace Fill



281

Destruction Level



484



485

CLASS 1
EPB V

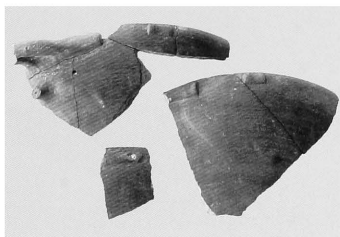

102 A-C



102 Detail

Terrace Fill



282

Destruction Level



486



487



488



489

CLASS 1

Destruction Level (cont.)



490



491



492



493



494

CLASS 1

Destruction Level (cont.)



495

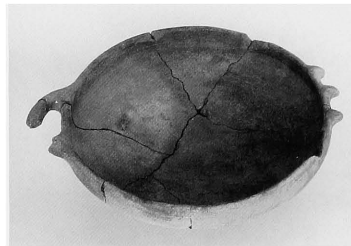

496



497



498

CLASS I

Destruction Level (cont.)

Bowls in Wavy-Line Style

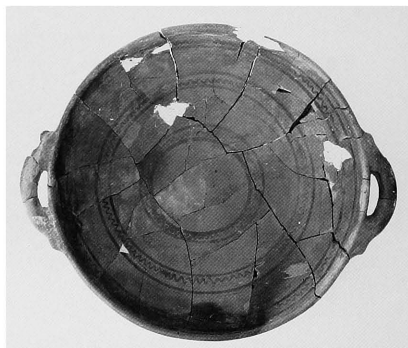

499



500



501

CLASS 1

Destruction Level (cont.)



CLASS 2

Destruction Level



503



504

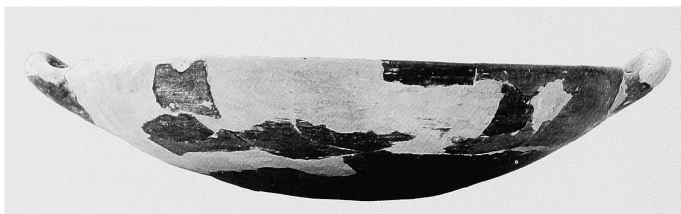

505



506

CLASS 2

Destruction Level (cont.)



507



508 Interior

CLASS 2 (cont.)

Post-Destruction Contexts

Brown-on-Buff Ware



1036



1037 Exterior



1037 Interior

CLASS 3

Destruction Level



509



510



511



512



513



514

EPB III



40

Destruction Level



515



516



517



518



519

Destruction Level (cont.)



520



521



522

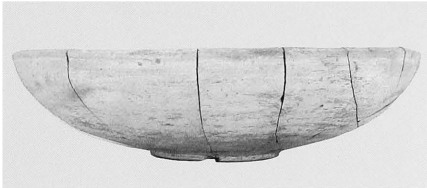

523



524



525



526

Terrace Fill

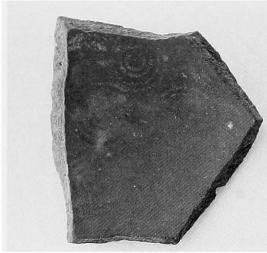

290

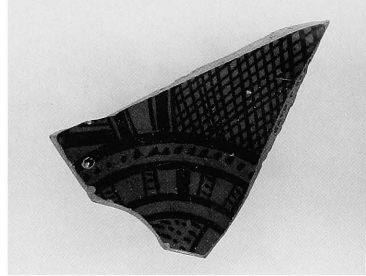

291

Destruction Level

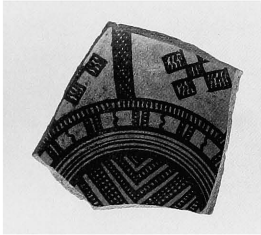

527



528

EPB II b



22

EPB V



110

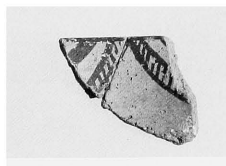

113 Exterior, Interior



114

EPB VI

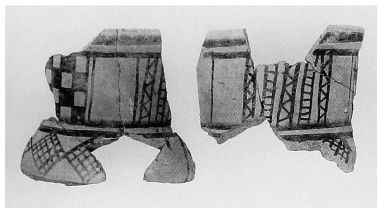

180



181

Meg. 5, Fill Below Floor



248

Terrace Fill



294



295

Destruction Level

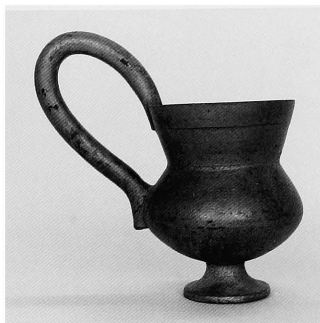

529



530



531



532

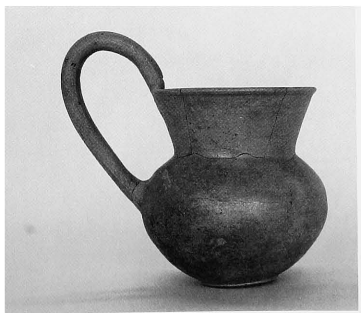

533



534

Destruction Level (cont.)

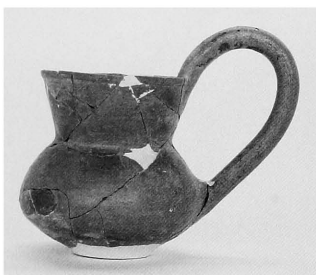

535

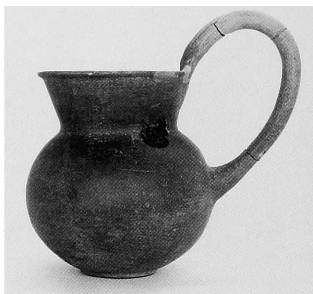

536

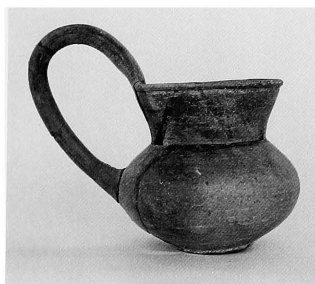

537

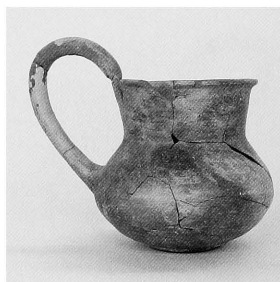

538

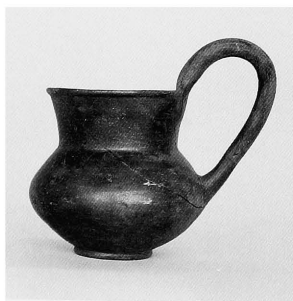

539

Destruction Level (cont.)

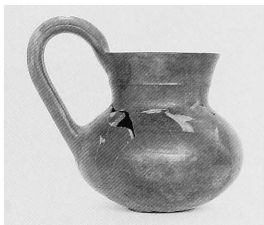

540

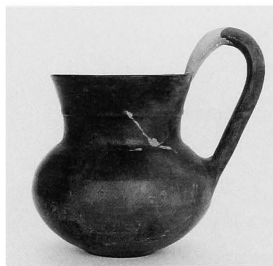

541

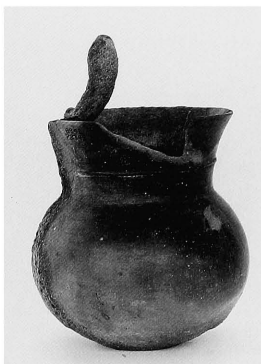

542



543

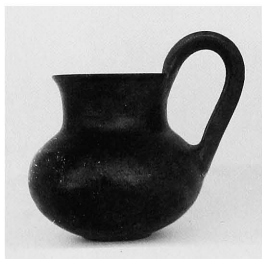

544



545



546

Destruction Level (cont.)



547

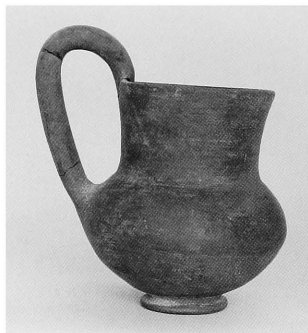

548



549

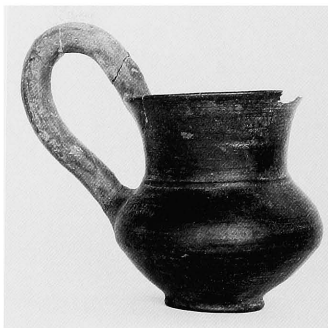

550

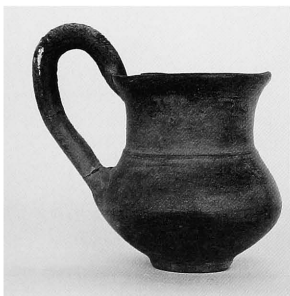

551

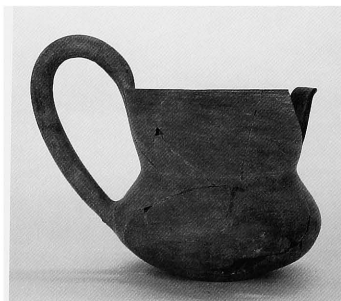

552

Destruction Level (cont.)



553



554



555



556



557



558

Destruction Level (cont.)



559

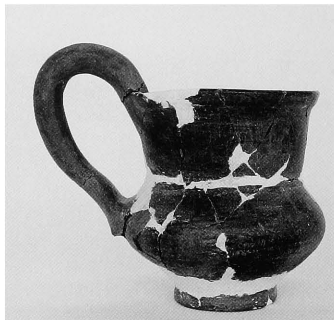

560



561

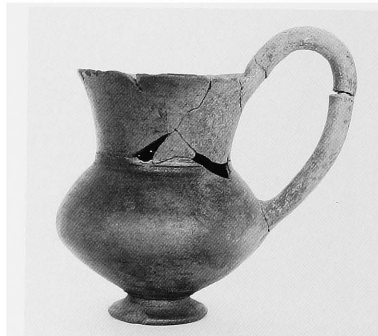

562



563

Destruction Level (cont.)

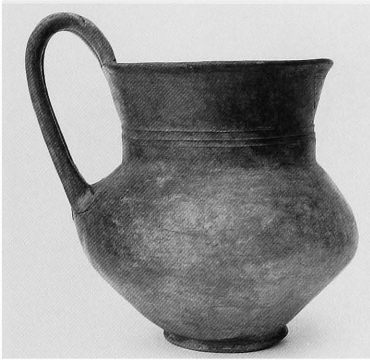

564

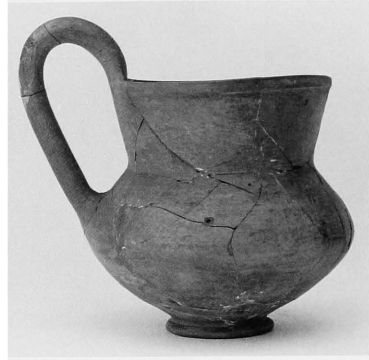

565

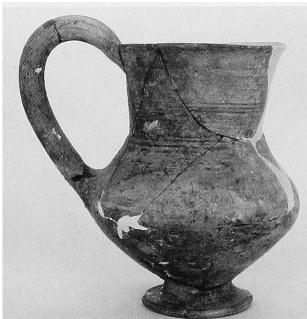

566

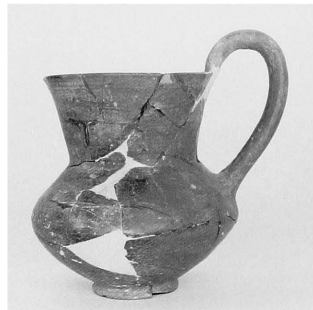

567

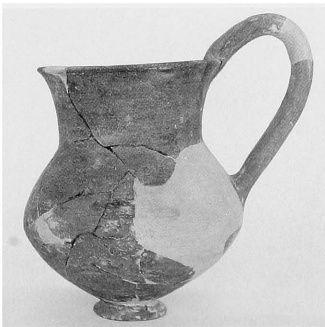

568



569

Destruction Level (cont.)



570



571



572



573



574

Destruction Level (cont.)



575



576



577



578



579



580



581

Destruction Level (cont.)



582

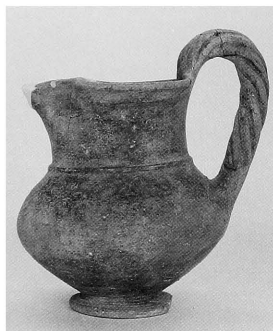

583



584



585

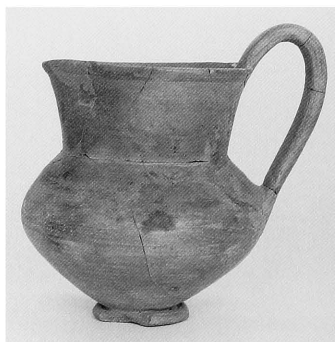

586

Destruction Level (cont.)



587



588



589



590



591



592



593



594



595



596



597

Destruction Level (cont.)

Wavy-Line Style

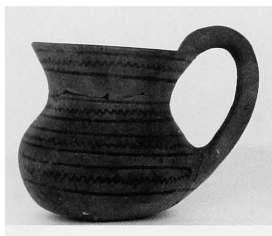

598

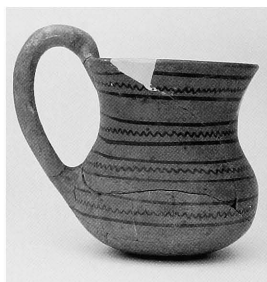

599



600



601

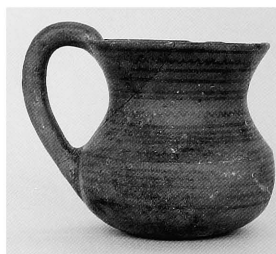

602



603



604

Destruction Level

Wavy-Line Style (cont.)



605



606



P 4682



607



Chevron-Triangle Style



608



609



610

Destruction Level (cont.)

Polychrome House Style

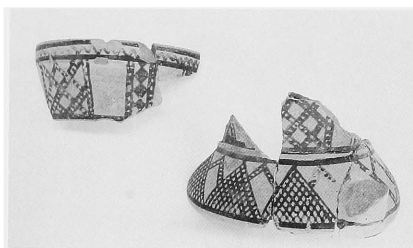

611 A-B

TB 8 Group

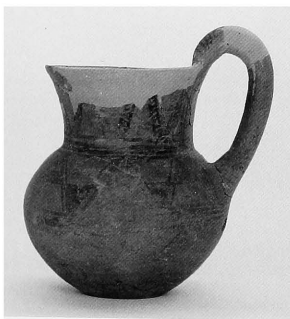

612

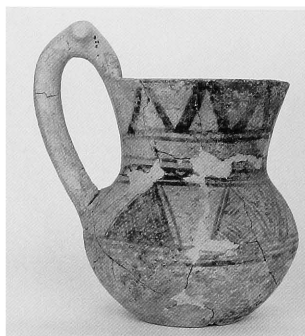

613



614



615

Destruction Level (cont.)

Other Painted



616

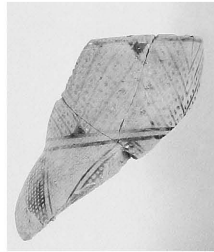

617



618

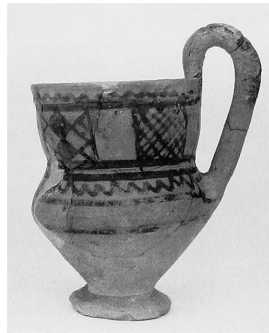

619



620

Destruction Level

Other Painted (cont.)



621



622

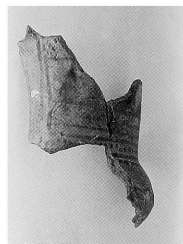

623

Ground Coated



624

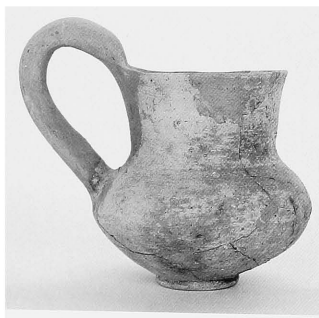

625



626

Post-Destruction Contexts

Brown-on-Buff Ware



1038



1039



1040

1038, 1039 - 2:3
1040 - 4:3

EPB II b



23

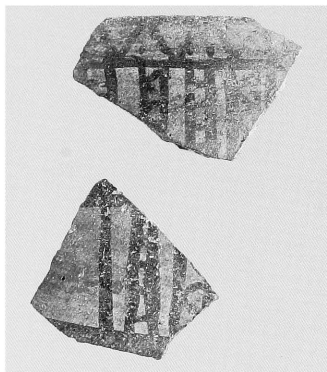

116

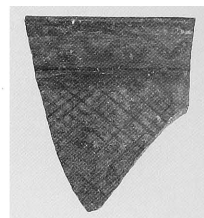

117

PN 3



240

Terrace Fill

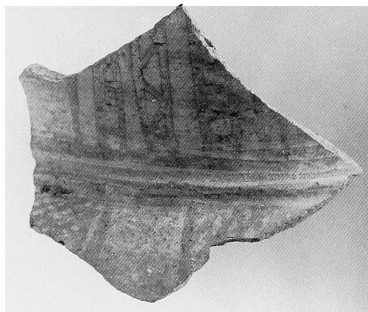

296

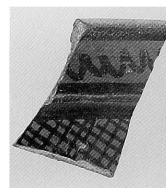

297

Destruction Level

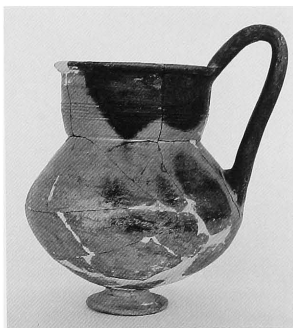

627

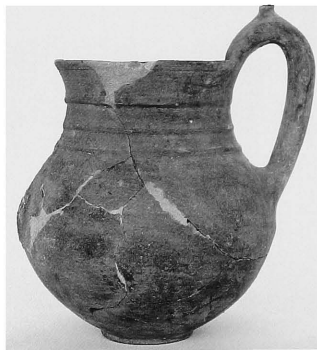

628

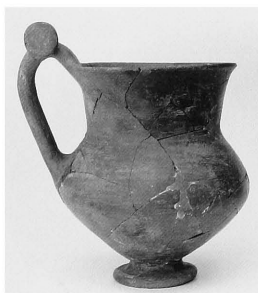

629



630



631

Destruction Level (cont.)
Wavy-Line Style



632



633

Fine-Line Buff Ware

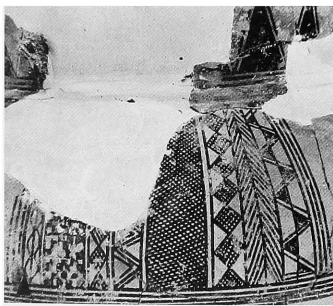
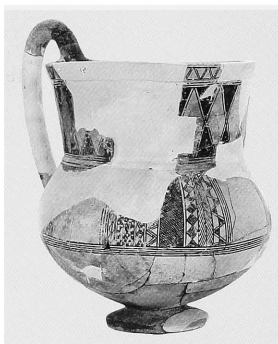

634

Destruction Level

Fine-Line Buff Ware (cont.)

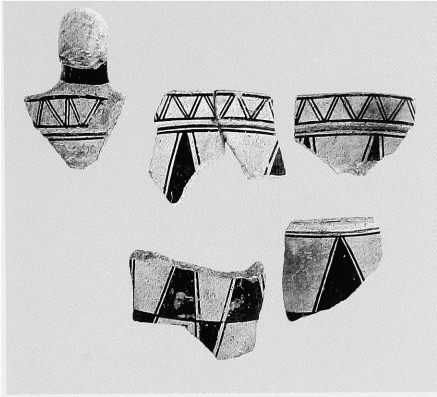

635

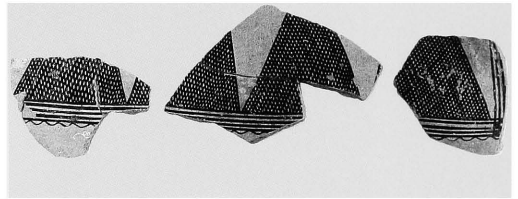

636

Other Painted



637

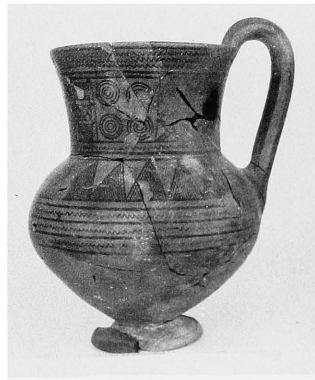

638

Destruction Level

Other Painted (cont.)



639

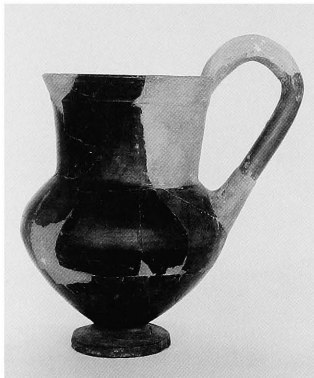

640

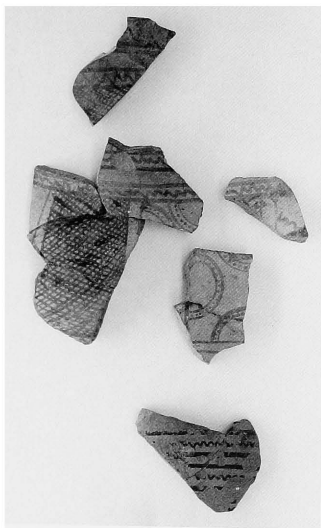

641



642



643



644

Tumulus Y

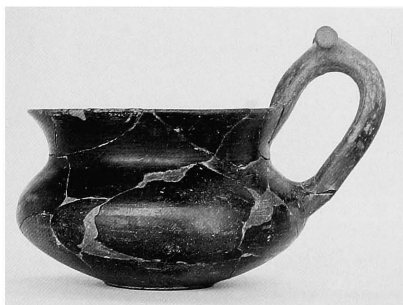

P 3160

Tumulus G

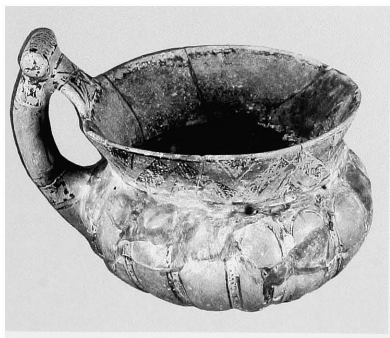

P 45



P 49

EPB III



43

EPB V



118



119

Terrace Fill



298

Destruction Level



645



646



647



648

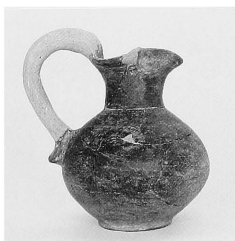

649



650

Destruction Level (cont.)



651



652

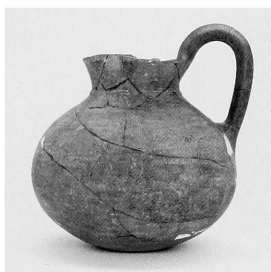

653

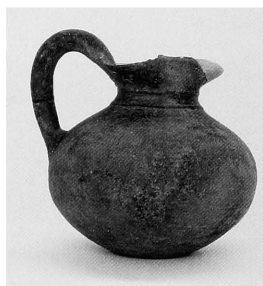

654



655



656



657

Destruction Level (cont.)



658



659



660



661



662



663



664



665

Destruction Level (cont.)



666



667

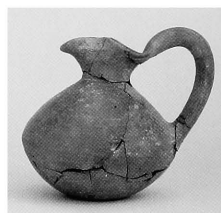

668



669



670



671



672



673

Destruction Level (cont.)



674



675



676



677

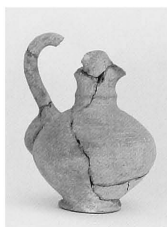

678



679



680

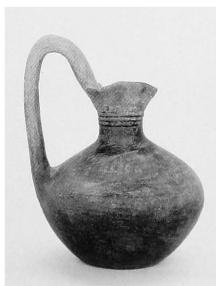

681



682

Destruction Level (cont.)



683

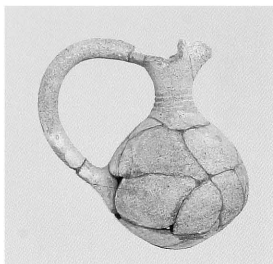

684



685



686



687



688



689



690

Destruction Level (cont.)

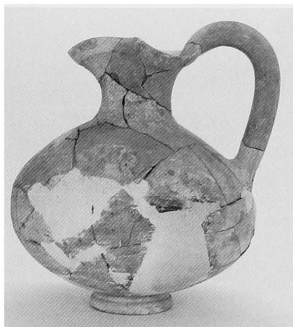

691



692

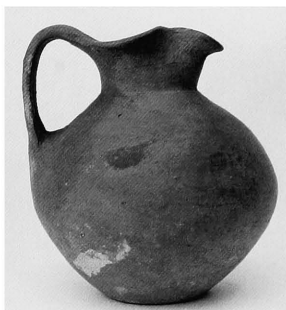

693



694



695

Destruction Level (cont.)



696



697

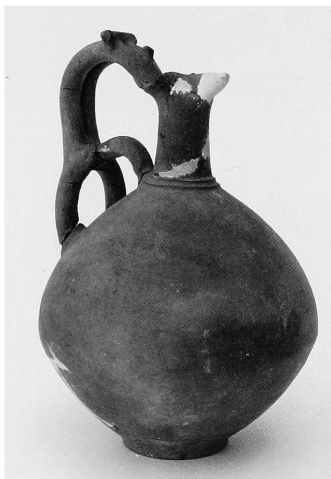

698



Destruction Level (cont.)

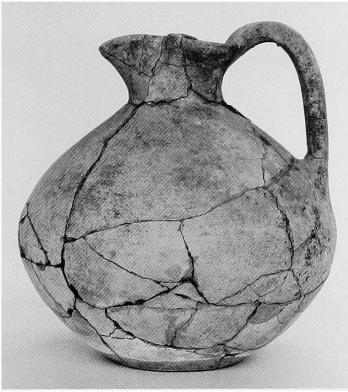

699

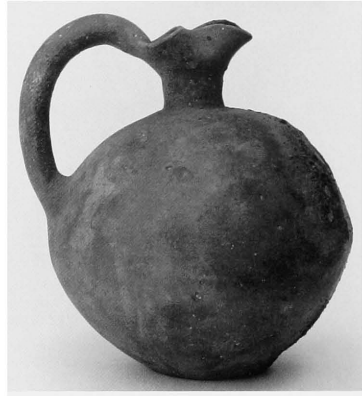

700

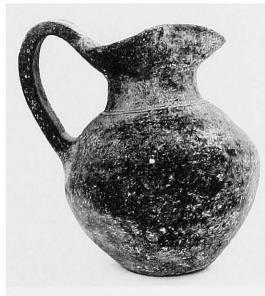

701

Stamped



702



702 Bottom

Destruction Level

Stamped (cont.)

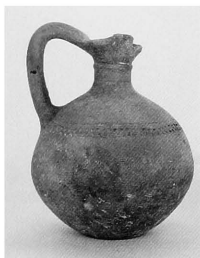

703

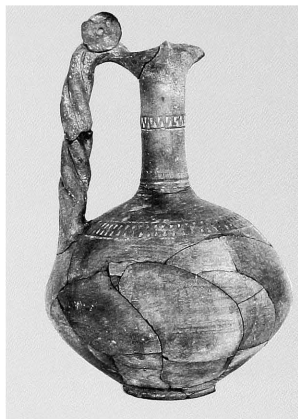

704

Wavy-Line Style



705



706

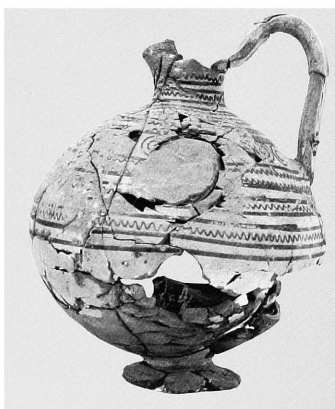

707

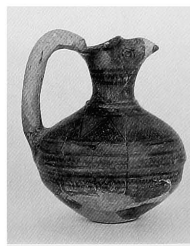

708

Destruction Level (cont.)

TB 8 Group

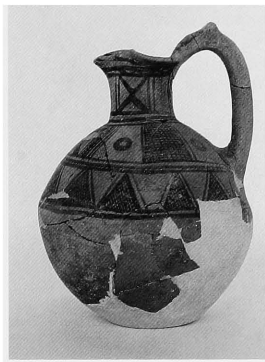

709

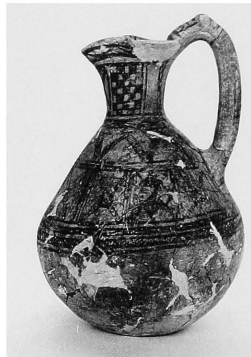

710

Other Painted (Small)



711



712



713

Destruction Level

Other Painted (Small) (cont.)



717

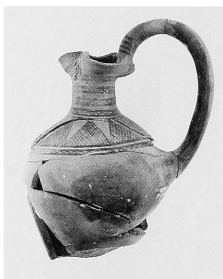

718

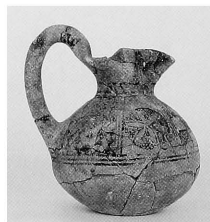

719

Other Painted (Medium)

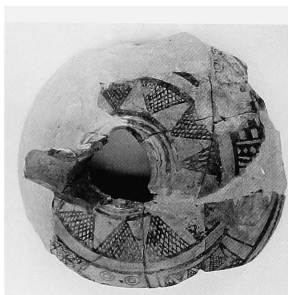

714



715

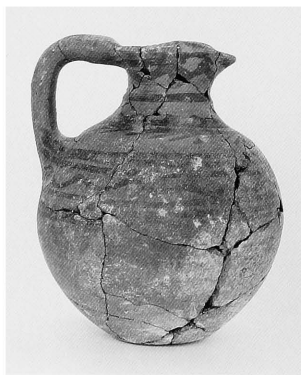

716

Destruction Level

Other Painted (Medium) (cont.)



720

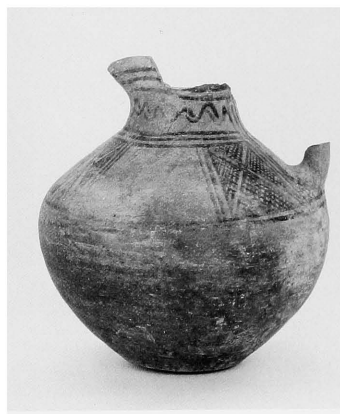

721

Ground Coated

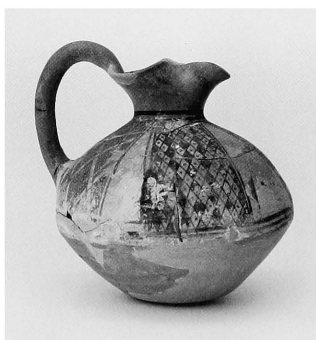

722

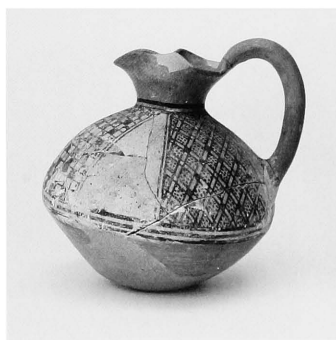

PLATE 76

EPB III



44

LARGE NARROW-NECKED TREFOIL JUGS

EPB V



120



121

Destruction Level



723



724

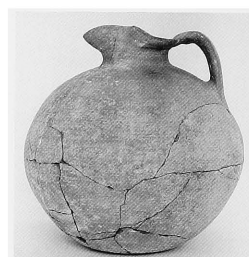

725



726

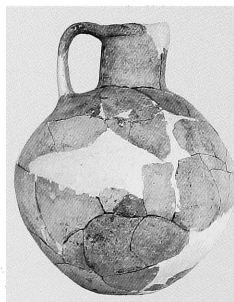

727

Destruction Level (cont.)

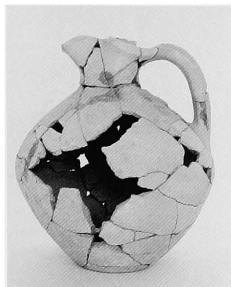

728



729



730



731



732



733

Destruction Level (cont.)



734

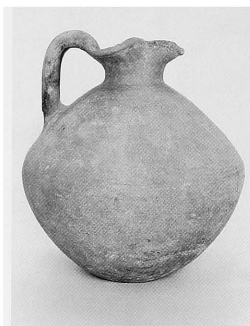

735

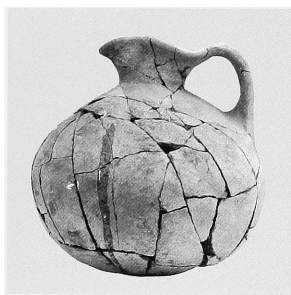

736

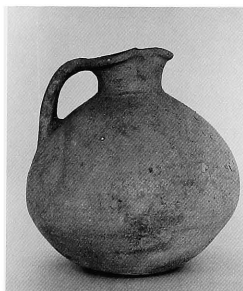

737



738

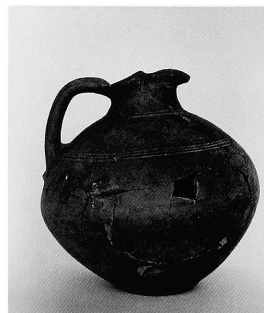

739

Destruction Level (cont.)



740



741



742

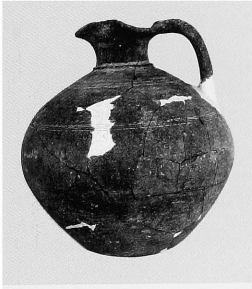

743



744



745



746

Destruction Level (cont.)



747



748



749



750

Ground Coated



751

EPB V

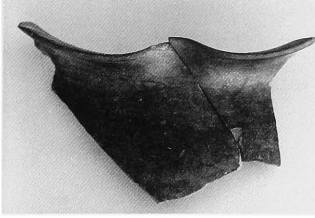

124

Terrace Fill

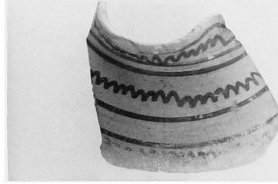

300

Destruction Level

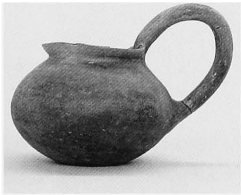

752

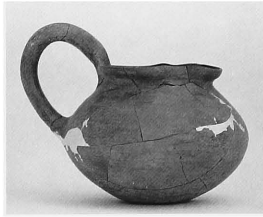

753

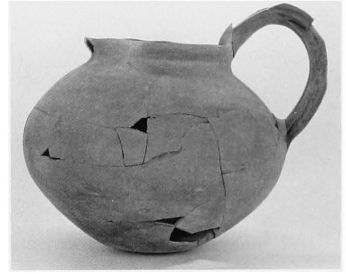

754



755



757



758



756

Destruction Level (cont.)



759



760

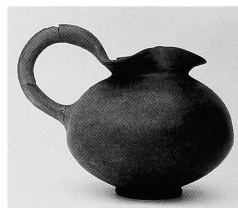

761



762



763



764



766

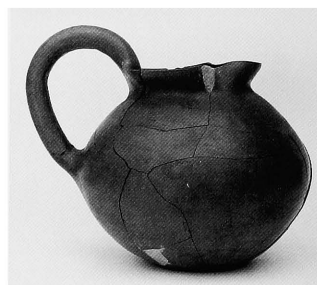

767



765

Destruction Level (cont.)

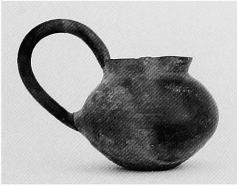

768



769



770



771

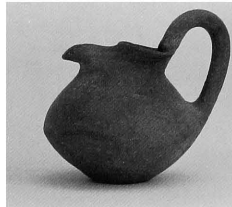

772



773



774



775

Destruction Level (cont.)

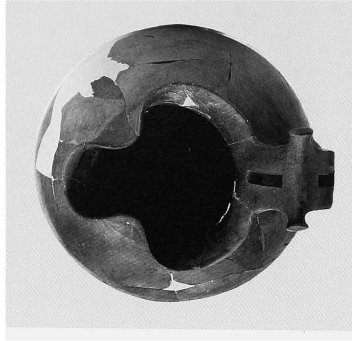

776



777

Destruction Level (cont.)

Wavy Line Style

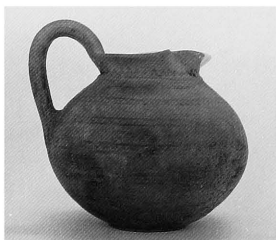

778



779

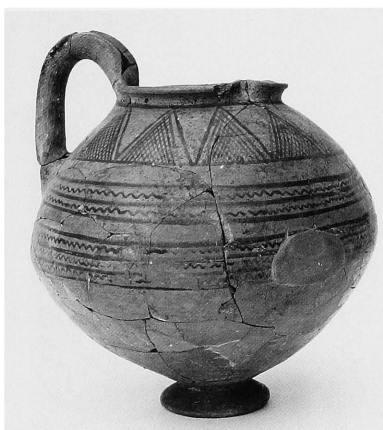

780

Other Painted

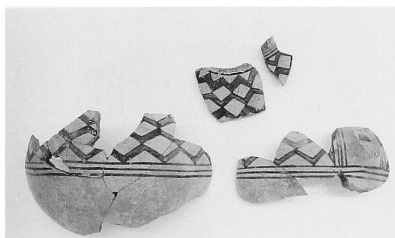

782

NARROW-NECKED, ROUND MOUTHED

EPB V



125

Destruction Level



783

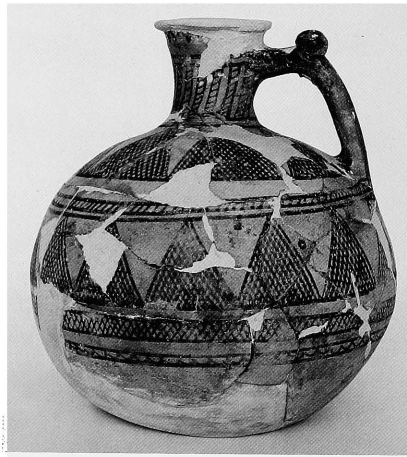

785

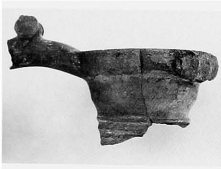

784

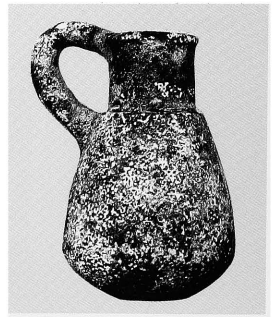

786

1:4
784 - 1:3
786 - 1:2
785 - 1:2
783 - 1:2

SPOUTED

EPB V

Terrace Fill

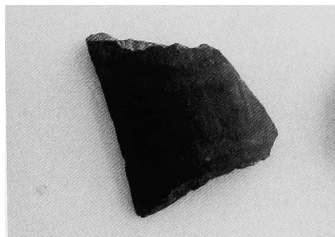

126

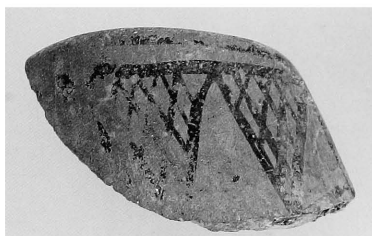

301

Destruction Level



787

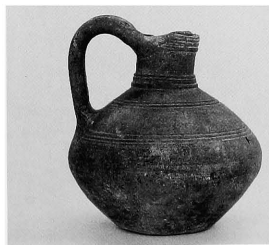

788



789

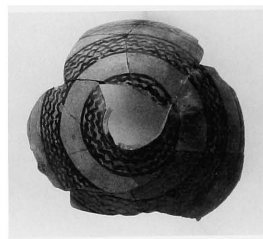

790

Destruction Level

Miniature Jug with Side Spouts



791

Jug with Duofoil Mouth



792

Ring-Shaped Jug

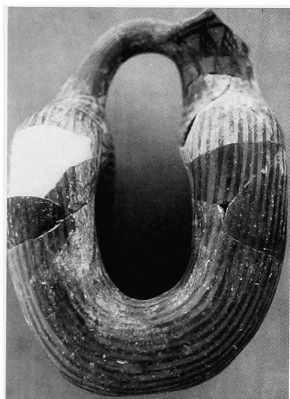

793

AMBIGUOUS JUGS

EPB II b

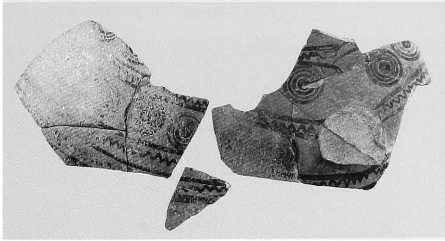

29

EPB V



127

EPB VII

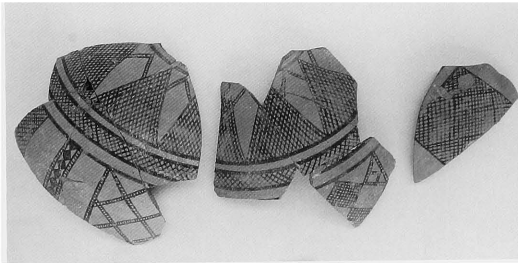

184

Destruction Level

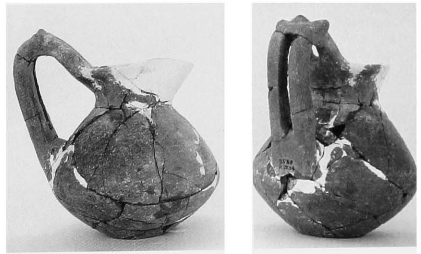

794

Destruction Level

Stamped



796



795

Destruction Level (cont.)

Wavy-Line Style



797



798

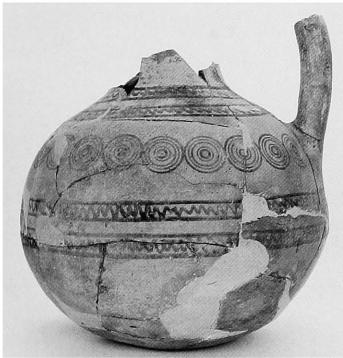

799



800

Fine-Line Buff Ware

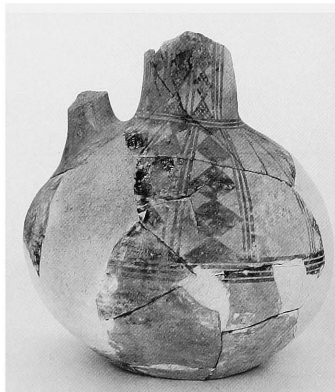

801

Destruction Level (cont.)

Ladders-and-Zigzags Style



802



803

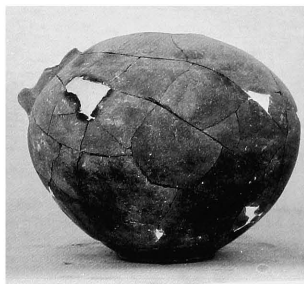

804

TB 8 Group



805



806

Group of 932



807

Destruction Level (cont.)

Other Painted



809



810

Post-Destruction Contexts

Brown-on-Buff Ware

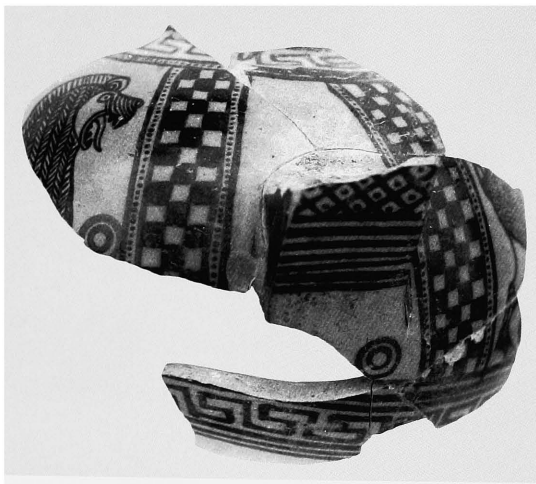

1041



P967c, b

Destruction Level

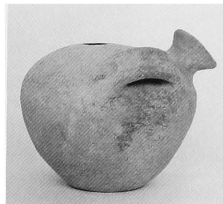

811

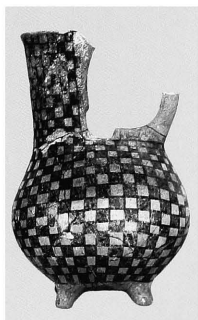

812

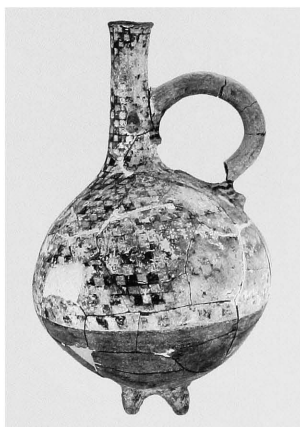

814

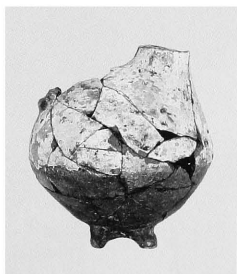

813



815

PLATE 94

EPB V

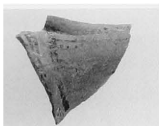

129

SIDE-SPOUTED SIEVE JUGS

Terrace Fill



302

TYPE 1

Destruction Level



816



817

TYPE 2

Destruction Level



818



819



820

TYPE 2

Destruction Level (cont.)



821



822



823

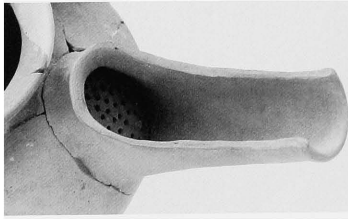

824



825

TYPE 3

Destruction Level



826

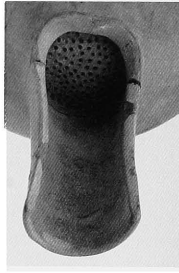

827



828



829



830



831

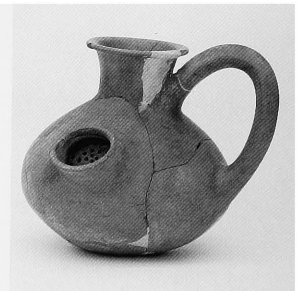

TYPE 3

Destruction Level (cont.)

Brown-on-Buff Ware

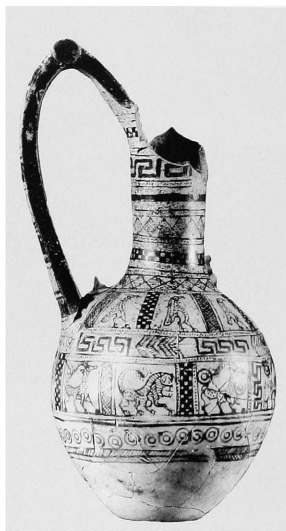

TYPE 3

Destruction Level (cont.)

Other Painted

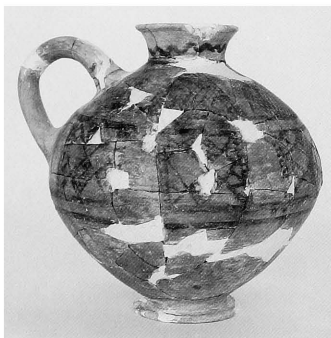

833



834

Ambiguous



835

Post-Destruction Contexts

Brown-on-Buff Ware

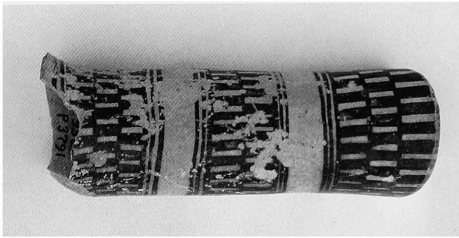
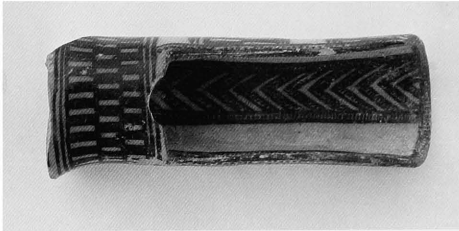

1042

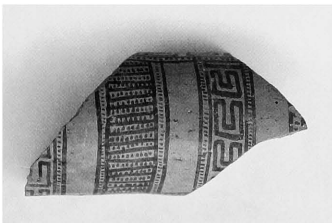

1044



1045

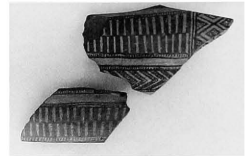

1043



1046



1047

Tumulus X

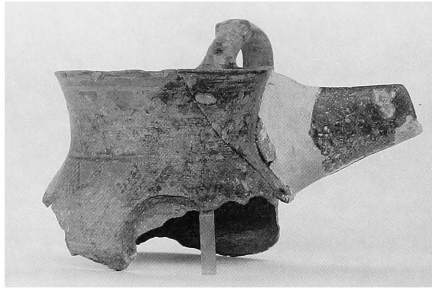

P3136

Tumulus III



K-III 19 / Spout Detail



K-III 21 / Spout Detail

Destruction Level



836

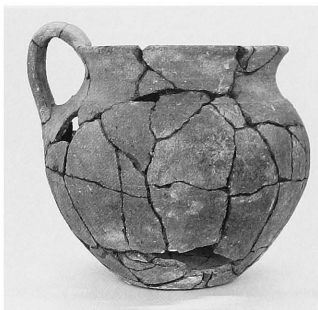

837



838

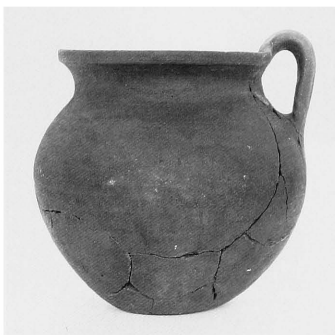

840



839



841



842

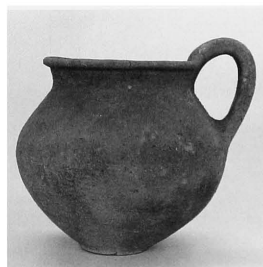

843

Destruction Level (cont.)



844

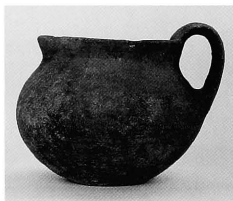

845

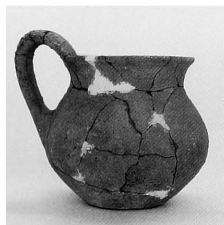

846



847



848



849



850

Tumulus III



K-III 29 & 31

Destruction Level



851 on 573



852 on 836



853 on 838



854 on 843



855



856 on 748



857

RHYTON
Destruction Level

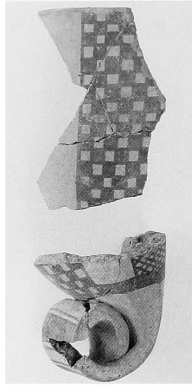

858

SIPPING CHALICE
Destruction Level



859

SIPPING BOWL

Destruction Level



860

PAN WITH PITTED BOTTOM

Destruction Level

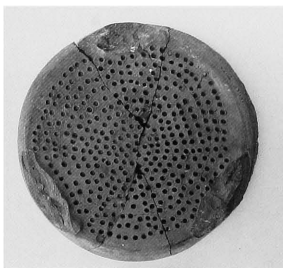

863

BOWLS WITH PERFORATED COVERS

Destruction Level



861



862

Destruction Level



864



865 supporting 821

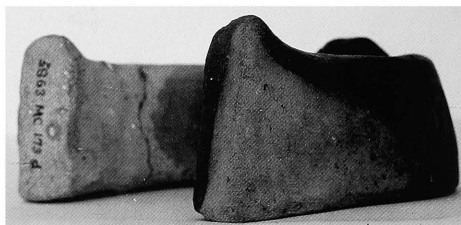

MC 173



866

Destruction Level (cont.)



867



868



869

Destruction Level (cont.)

Group of 932



870



871

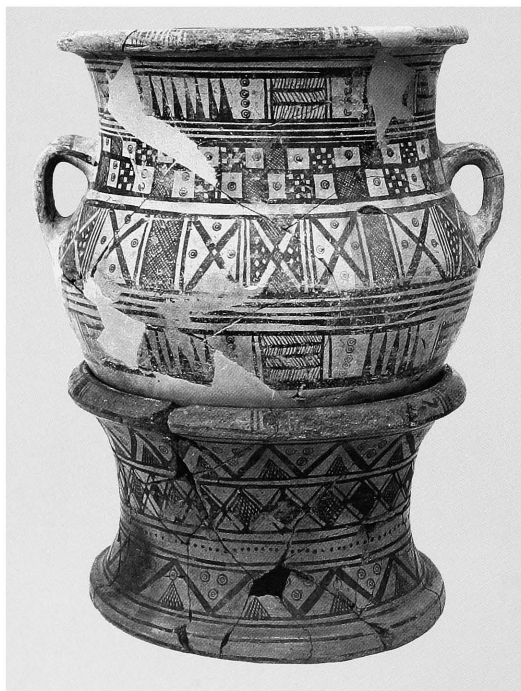

871 supporting 930

SMALL AMPHORAS

Destruction Level



872



873



874



875

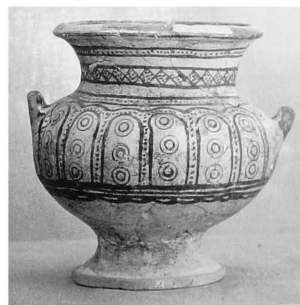
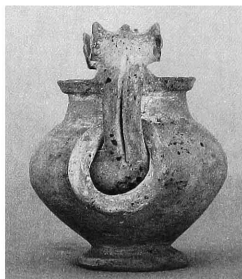

876

KANTHAROS KRATERS

Destruction Level



877

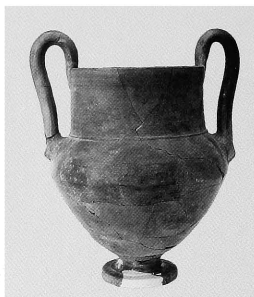

878

Polychrome House Style



879



880

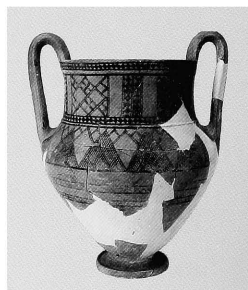

Other Painted



881

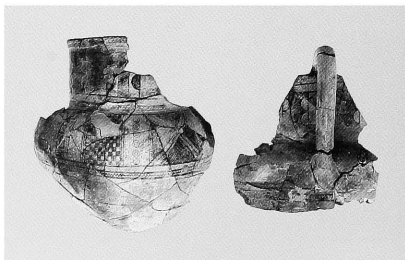

882

NARROW-NECKED AMPHORAS, NECK-HANDLED

Destruction Level



883

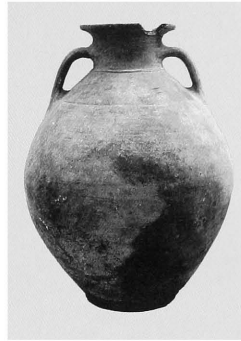

884

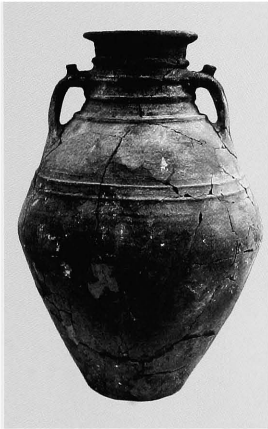

885



886

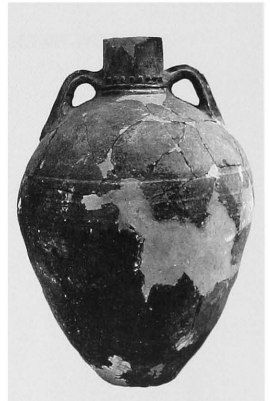

887

NARROW-NECKED AMPHORAS, NECK-HANDLED

Destruction Level (cont.)

Incised Decoration



888

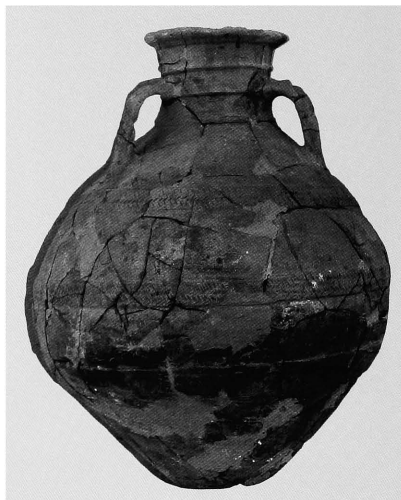

889

NARROW-NECKED AMPHORAS, SHOULDER-HANDLED

EPB VII



185

NARROW-NECKED AMPHORAS, SHOULDER-HANDLED

EPB VII (cont.)

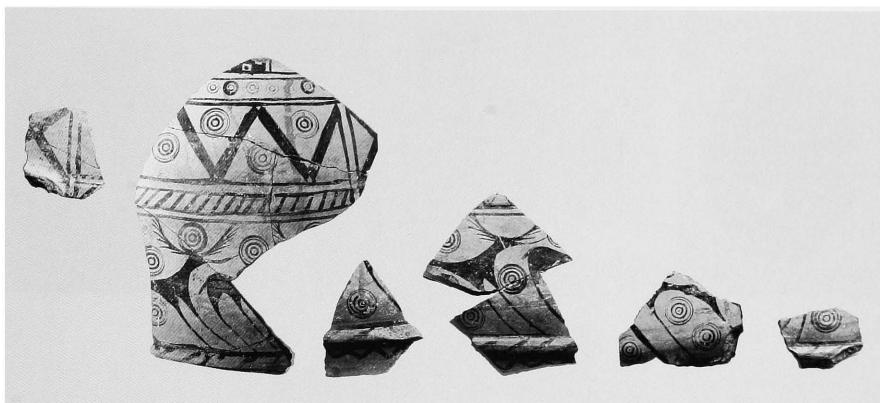

Destruction Level



890



891



892



893

NARROW-NECKED AMPHORAS, SHOULDER-HANDLED

Destruction Level (cont.)



894

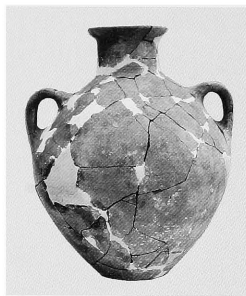

895

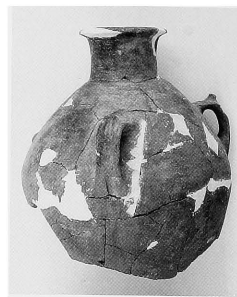

896

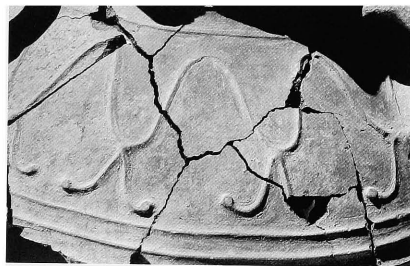

897

NARROW-NECKED AMPHORAS, SHOULDER-HANDLED
Destruction Level (cont.)

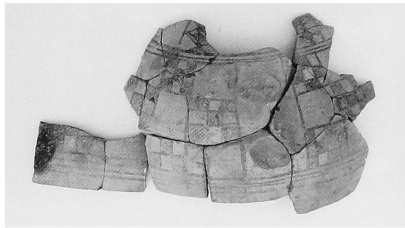
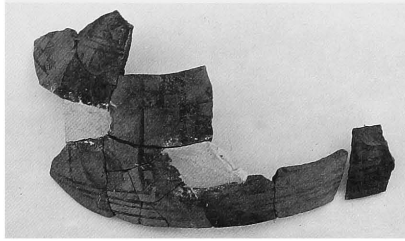

898

OPEN-MOUTHED AMPHORAS
EPB V

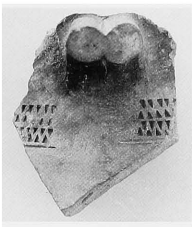

133



135

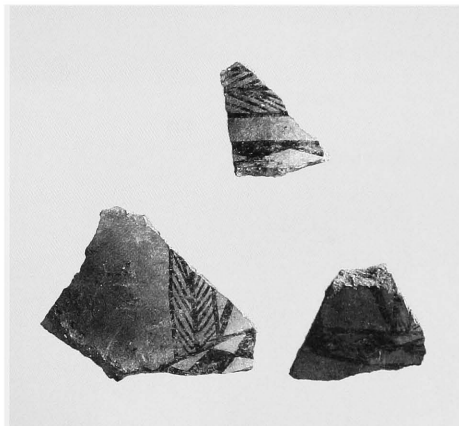

134

OPEN-MOUTHED AMPHORAS (cont.)

PN3



241

Terrace Fill



305



306

Incised



311

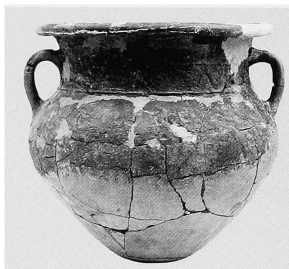

308

Stamped



312

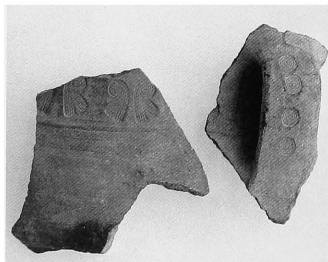

313 A-B

311, 313 - 2:5
305, 306, 308 - 1:10
241, 312 - 3:10

OPEN-MOUTHED AMPHORAS

Terrace Fill (cont.)

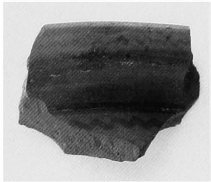

314

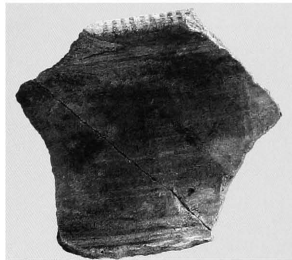

315

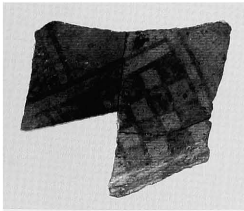

319



318

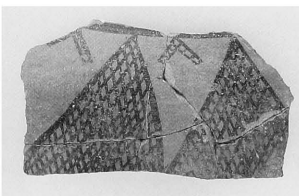

317

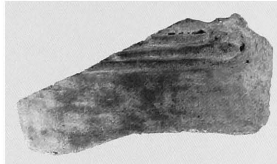

316B

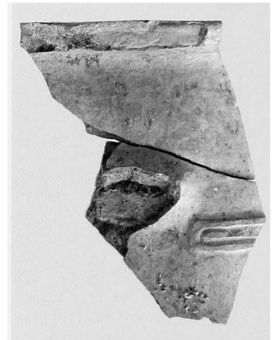

316A



320

OPEN-MOUTHED AMPHORAS (cont.)

Destruction Level



899

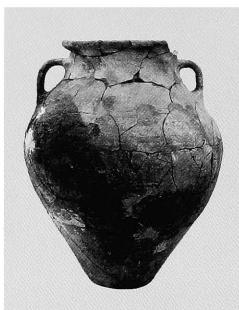

900

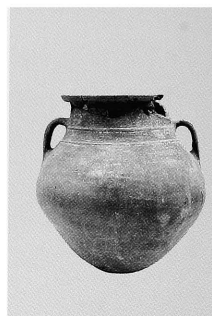

901



902



903



904

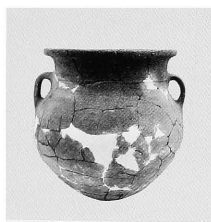

905



906

OPEN-MOUTHED AMPHORAS

Destruction Level (cont.)



907

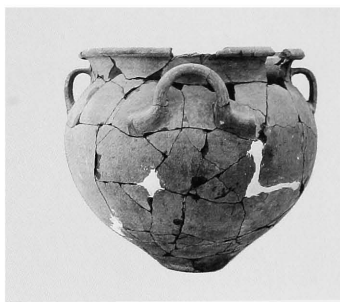

908



909

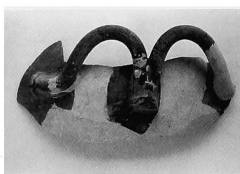

910 A, B

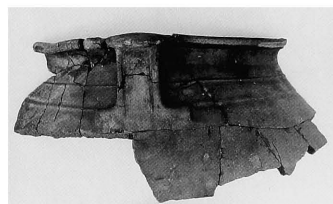

911



913



912 A, B



OPEN-MOUTHED AMPHORAS

Destruction Level (cont.)

Incised



914



915

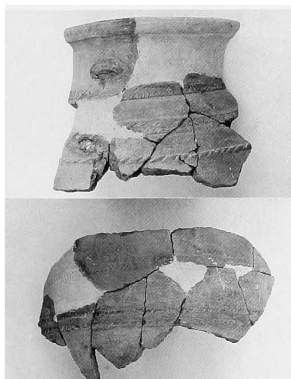

916 A, B

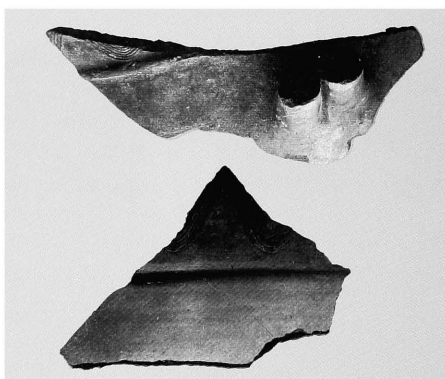

917

Stamped

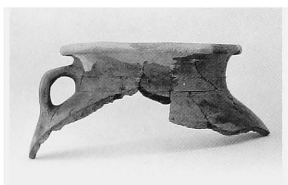

918



919

OPEN-MOUTHED AMPHORAS

Destruction Level

Stamped (cont.)

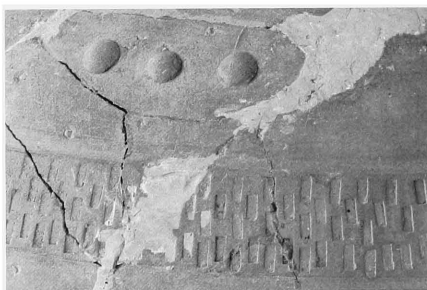
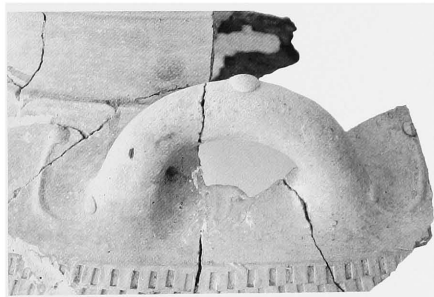

920



921

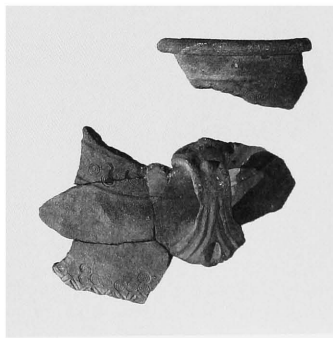

922

OPEN-MOUTHED AMPHORAS

Destruction Level (cont.)

Painted



923

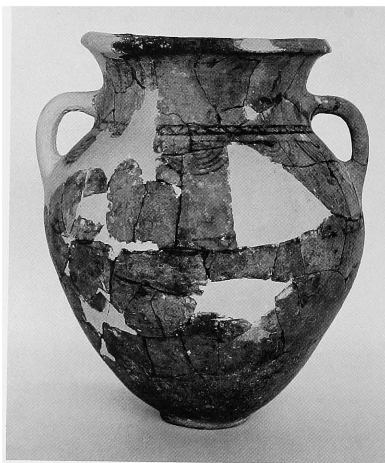

924



925

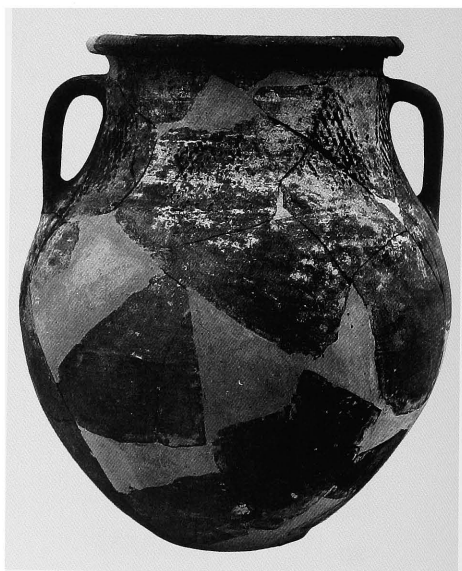

926

OPEN-MOUTHED AMPHORAS

Destruction Level

Painted (cont.)

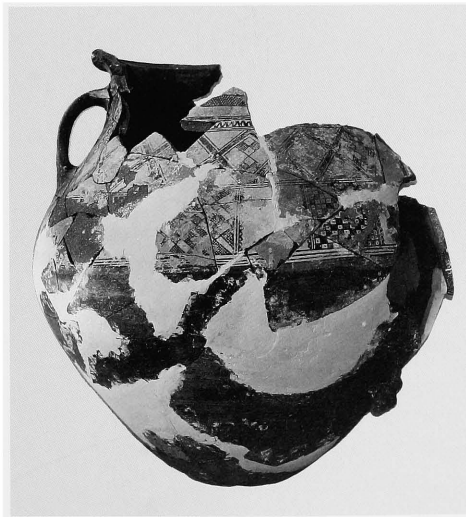
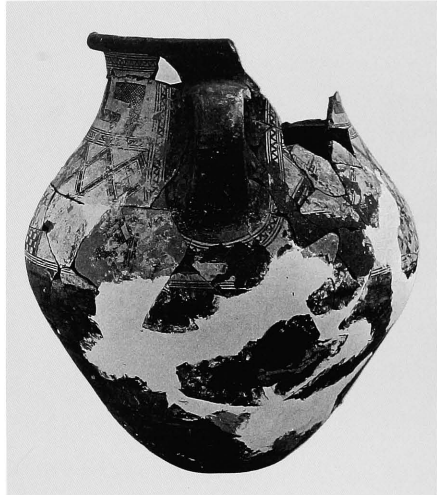

927

OPEN-MOUTHED AMPHORAS

Destruction Level

Painted (cont.)



929

OPEN-MOUTHED AMPHORAS

Destruction Level

Painted (cont.)



928

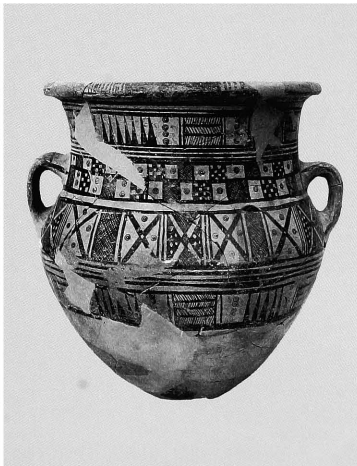

930

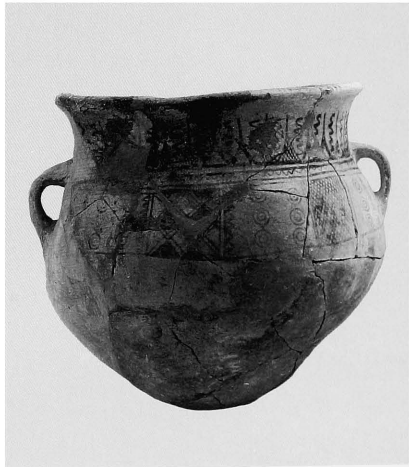

931

OPEN-MOUTHED AMPHORAS

Destruction Level

Painted (cont.)

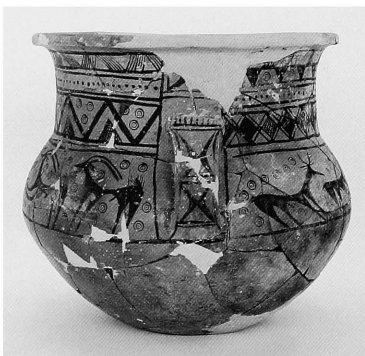
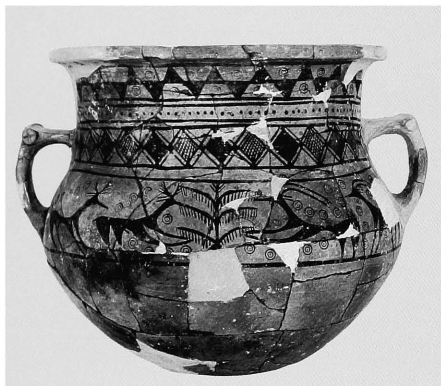

932

OPEN-MOUTHED AMPHORAS

Destruction Level

Painted (cont.)

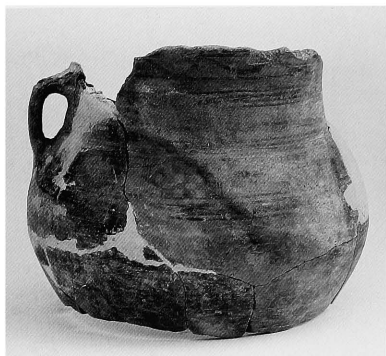

933



934

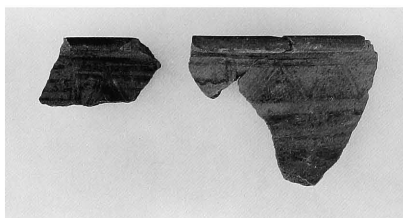

935

AMPHORAS/KRATERS IN STYLE OF BROWN-ON-BUFF WARE

Post-Destruction Contexts



1061



1062

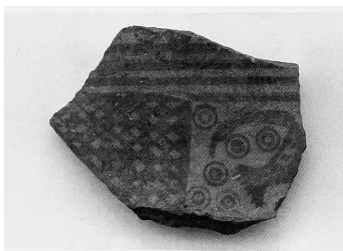

1063



1064

ENORMOUS KRATERS IN STYLE OF BROWN-ON-BUFF WARE

Post-Destruction Contexts (cont.)

Double Concentric Circle Group



1070



1070

1071

1072

1066



1065B



1065A

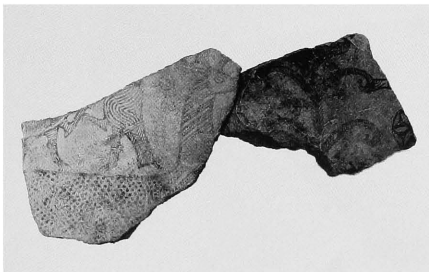

1067

ENORMOUS KRATERS IN STYLE OF BROWN-ON-BUFF WARE

Post-Destruction Contexts

Double Concentric Circle Group (cont.)



1073



1068



1069

ENORMOUS KRATERS IN STYLE OF BROWN-ON-BUFF WARE

Post-Destruction Contexts (cont.)

Triple Concentric Circle Group



1077 A (above), B-D (below)



1075

P544h



1074

1076

ENORMOUS KRATERS IN STYLE OF BROWN-ON-BUFF WARE

Post-Destruction Contexts (cont.)

Without Preserved Concentric Circles



1081

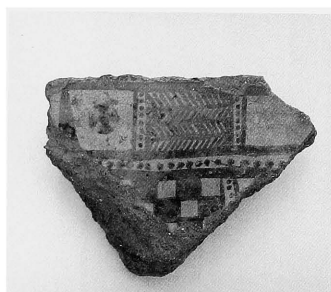

1079

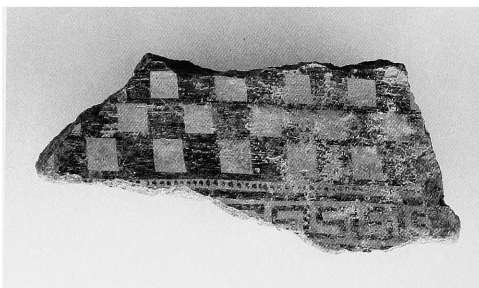

1080

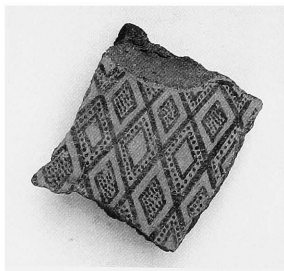

1078

AMPHORAS AND PROBABLE AMPHORAS IN THE ALIŞAR IV STYLE

Post-Destruction Contexts

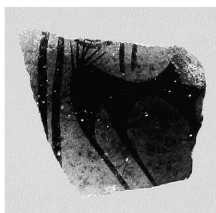

1082



1083

Ground-Coated



1084



1085



1086

Bichrome

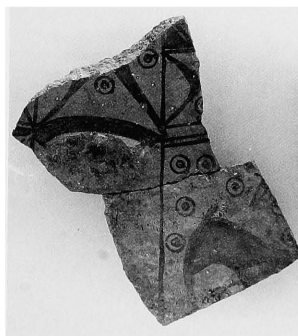

1087

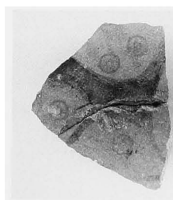

1088



1089

MISCELLANEOUS AND AMBIGUOUS

EPB III



50

Destruction Level

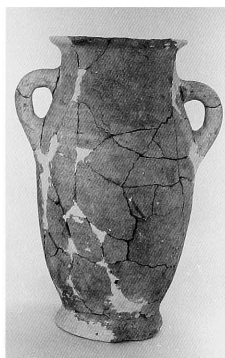

936



937

Stamped



938

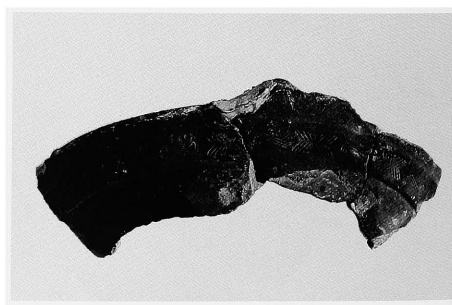

939

LOW-NECKED JARS AND DINOI

EPB IV



60

EPB V

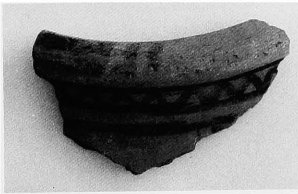

137



138



139

EPB VII



183

Terrace Fill



321



322

LOW-NECKED JARS AND DINOI (cont.)

Destruction Level



940



941



942



943



944



945



946



947



948



949



950



951

LOW-NECKED JARS AND DINOI

Destruction Level (cont.)



952

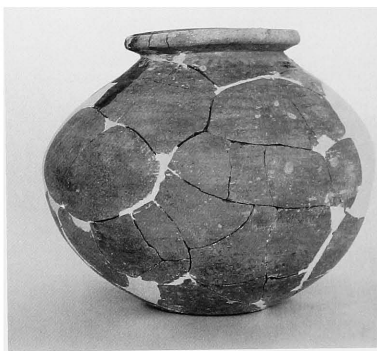

953



954



955



956



957



958

LOW-NECKED JARS AND DINOI

Destruction Level (cont.)



959



960



961



962



963

LOW-NECKED JARS AND DINOI

Destruction Level (cont.)

Painted

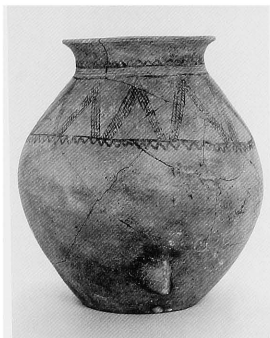

964

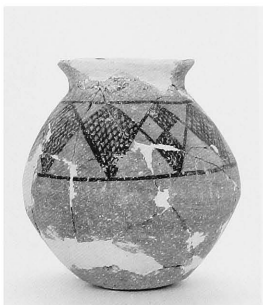

965

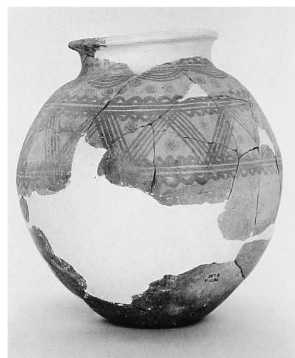

966

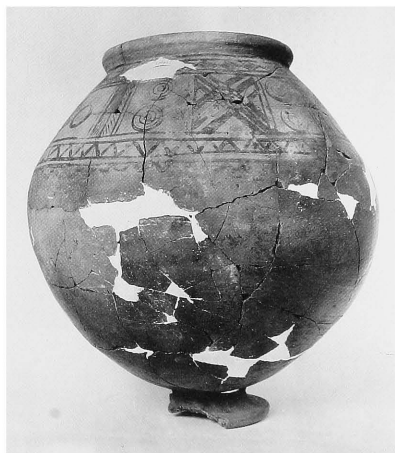

967



LOW-NECKED JARS AND DINOI

Destruction Level

Painted (cont.)



968



969



970



972



971

LOW-NECKED JARS AND DINOI

Destruction Level

Painted (cont.)



973



974

Grave under Tumulus D



P 32

Post-Destruction Contexts

Brown-on-Buff Ware



1048



1049

NECKED JARS

Destruction Level



975



976



977

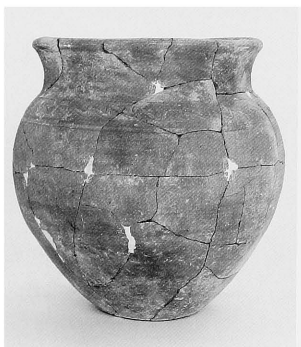

978



979



980

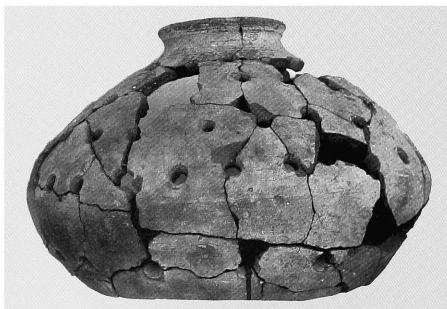

981

NECKED JARS
Destruction Level (cont.)
Painted



982



983



984

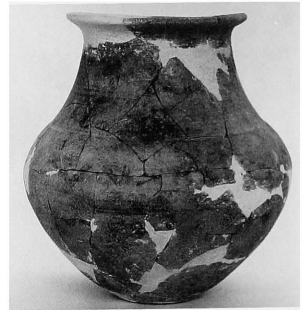

985

AMBIGUOUS JAR
Destruction Level
Stamped

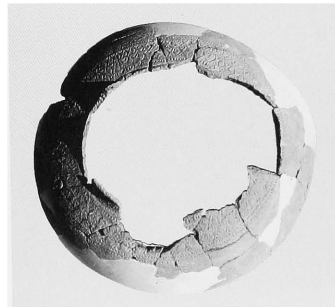

986

NARROW-NECKED STORAGE JARS

Terrace Fill



323

Destruction Level

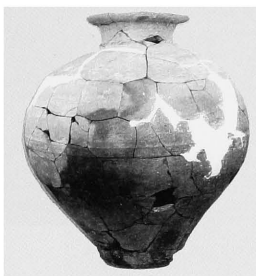

987



988



989



990



991

Tumulus P



Tum P 105, detail

WIDE-MOUTHED STORAGE JARS

Destruction Level



993



994

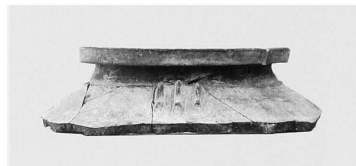
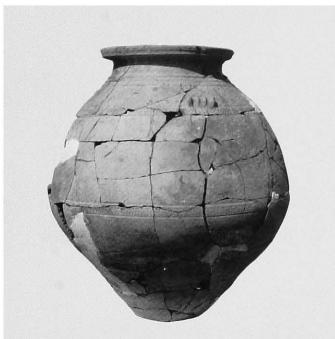

995

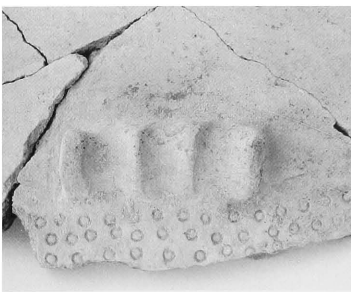

997



996

WIDE-MOUTHED STORAGE JARS

Destruction Level (cont.)



998



999



1002

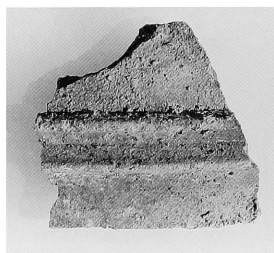

WIDE-MOUTHED STORAGE JARS

Destruction Level (cont.)

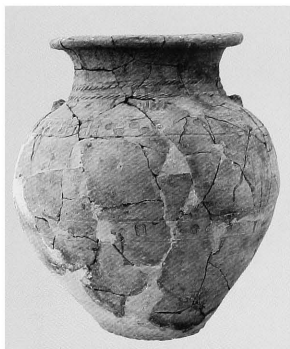

1000

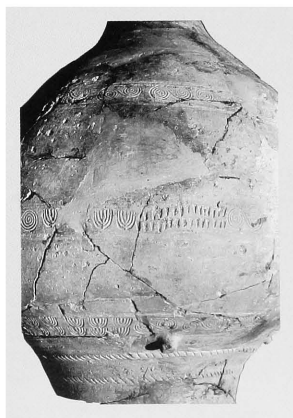
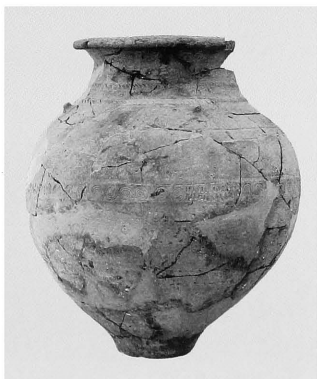

1001

WIDE-MOUTHED STORAGE JARS

Destruction Level (cont.)



1003 A, C, B

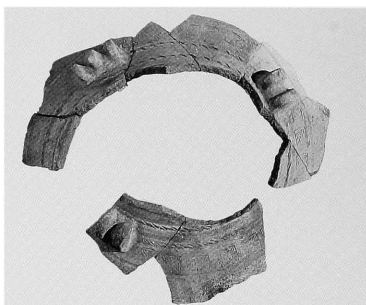

1004



AMBIGUOUS STORAGE JAR

Destruction Level



1005

PATTERN-BANDED STORAGE JARS

Terrace Fill



324

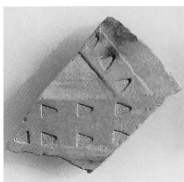

325

M411



407

Destruction Level

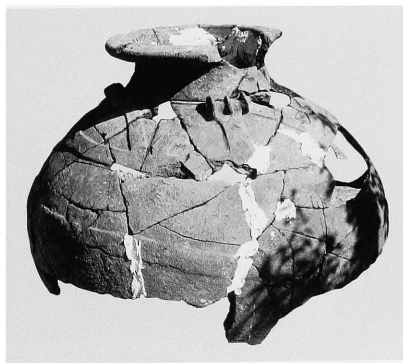

992



1006



1007



1008

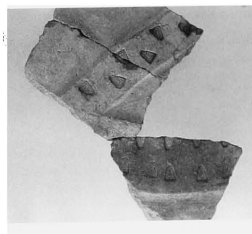

1009

PATTERN-BANDED VESSEL

EPB II b



26

HANDLES

EPB II b



28

EPB III



58

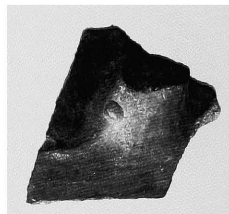

59

EPB V



161



162

HANDLES (cont.)

Meg. 10-2



195



196

Meg. 10-1



212

Terrace Fill



378



379



380



381



382

Destruction Level



1023

VESSELS WITH PATTERNED INCISION

PN 3



244

Terrace Fill

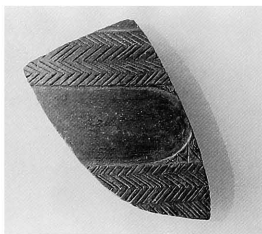

369



370



371

VESSELS WITH PATTERNED INCISION (cont.)

M4I



405

Destruction Level



1010



1011



1012



1022

STAMPED VESSELS

EPB V



163



164

NCT IV a



236

Meg. 5, Fill Below Floor



249

Terrace Fill

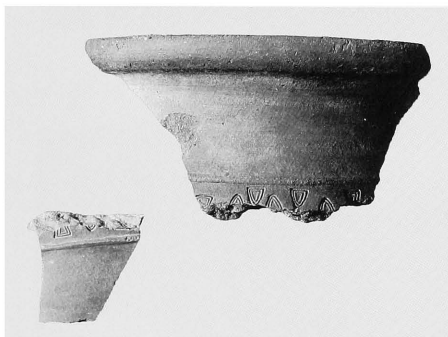

368

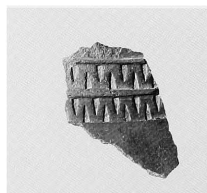

372

STAMPED VESSELS

Terrace Fill (cont.)

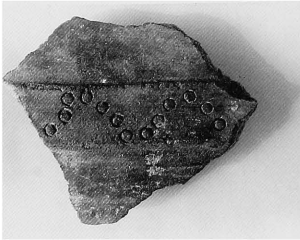

373

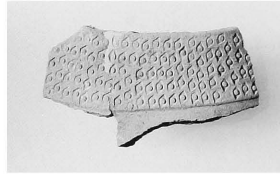

374

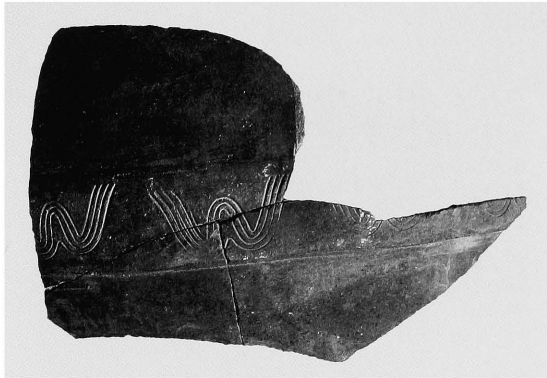

375

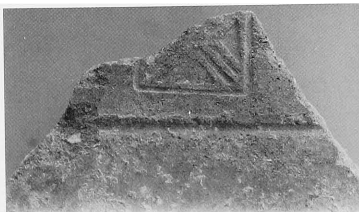

376



383

STAMPED VESSELS

Destruction Level



1013



1014

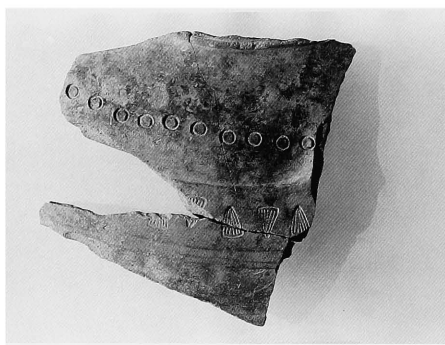

1015



1016

STAMPED VESSELS

Destruction Level (cont.)



1017



1018 B, A



1019



1020



1021

PLATE 158

AMBIGUOUS VESSELS: PAINTED

FINE-LINE BUFF WARE

EPB VI

EPB V

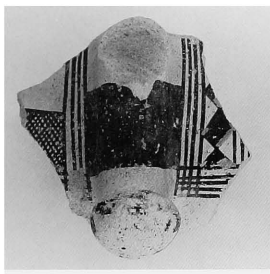

165

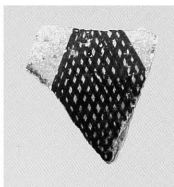

166

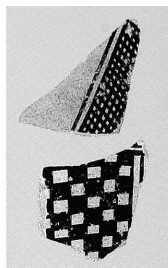

182, B, A

M4 I



406

BROWN-ON-BUFF WARE

EPB V

Terrace Fill

M4 III

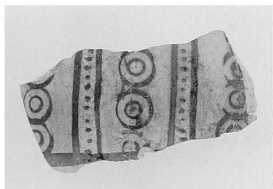

167



385



408

BROWN-ON-BUFF WARE (cont.)

Post-Destruction Contexts

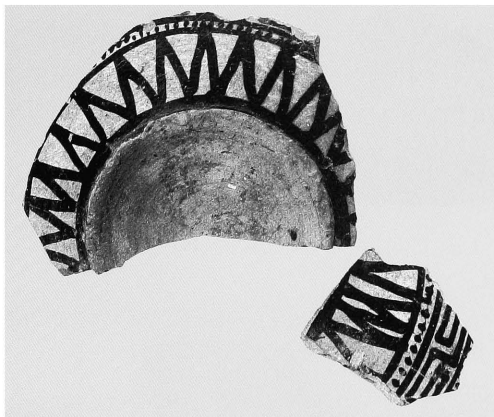

1050



1052



1051

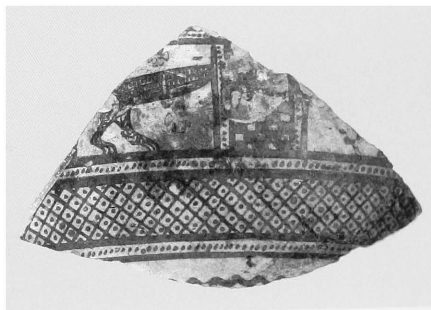

1053

BROWN-ON-BUFF WARE

Post-Destruction Contexts (cont.)

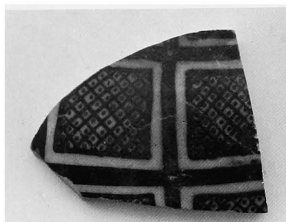

1054

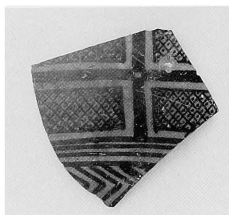

1055



1056



1057



1058



1059



1060

LADDERS-AND-ZIGZAGS STYLE

EPB V



168

POLYCHROME HOUSE STYLE

Terrace Fill

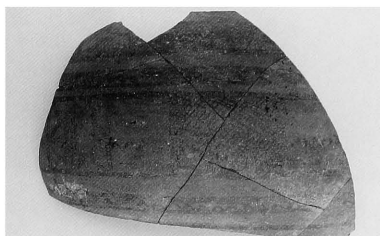

384

Destruction Level



1024

ALIŞAR IV STYLE

EPB V



169



170



171

OTHER PAINTED

EPB V

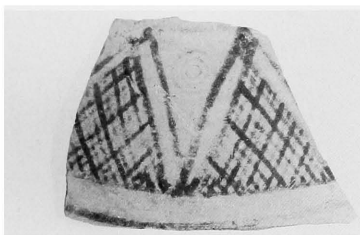

172

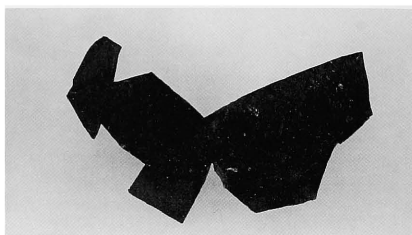

173



174

Meg. 5, Fill Below Floor



250

Terrace Fill



386

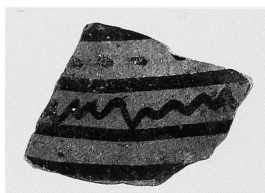

387



388

OTHER PAINTED

Terrace Fill (cont.)



389

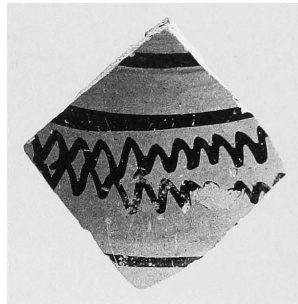

390

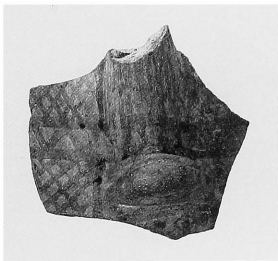

391



392



393



394

OTHER PAINTED

M4 III

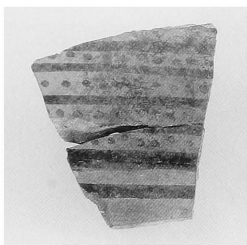

409

Destruction Level



1025



1026



1027



1028

OTHER PAINTED

Destruction Level (cont.)

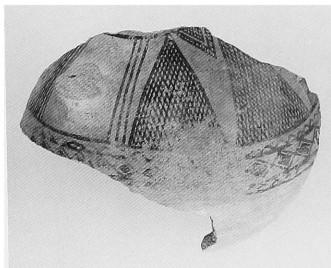

1029



1030

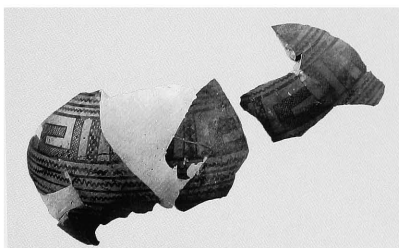

1031



1032



1033

1029 - 2:5
1030 - 1:4
1031 - 1:5
1032 - 1:2
1033 - 1:1

GROUND COATED

EPB V



175



176

PN 5

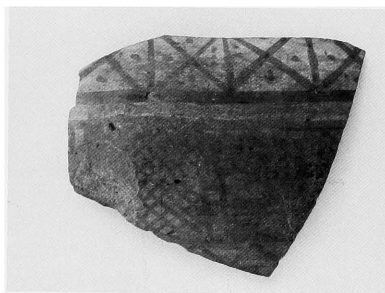

247

Terrace Fill



395

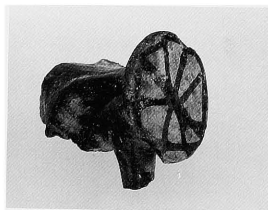

396

GROUND COATED

Terrace Fill (cont.)

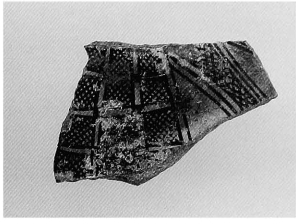

397



398 A, B

Destruction Level



1034



1035

1000: DETAILS OF UPPER STAMPED ZONE IN SEQUENCE



A Group 1



B Group 2



C Groups 3-4



D Group 5



E Group 6



F Group 7



G Groups 8-9



H Group 9



I Group 10



J Group 11

Details of Select Stampings



1013 Triangle-zigzag



1009 Diminishing triangles



1005 Chevron-triangles, concentric circle



313 B Spirals



1018 B Spirals, concentric horseshoes



404 Xs in circles



1003 A Filled circles



1004 X panels

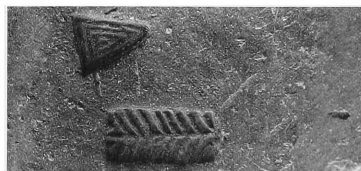

407 Diminishing triangles, herringbone



1008 Diminishing lozenges

Details of Select Stampings (cont.)



918 Chevron-triangles, S-spirals



922 S-spirals



1001 S-spirals



938 Modified S-spirals

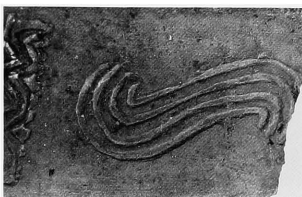

323 Rectangular stamping, S-curl



939 S-curls, chevrons



1020 S-curl



313A Spiral Fans



1001 Concentric horseshoes



1018 Concentric horseshoes



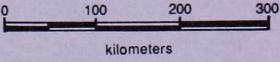
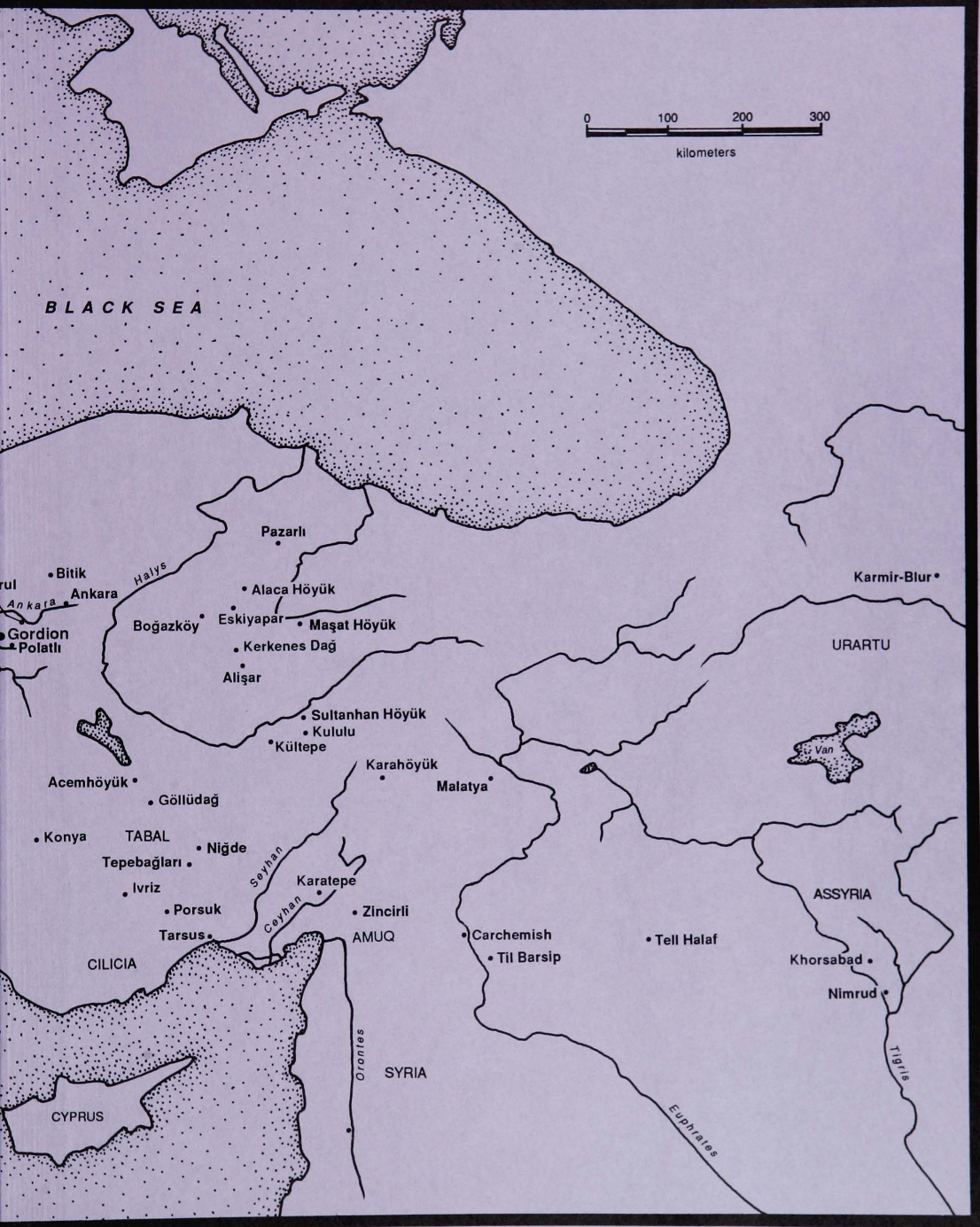

BLACK SEA

Karmir-Blur *

URARTU

ASSYRIA

SYRIA

CILICIA

TABAL

CYPRUS

Bitik
Ankara
Ankara

Halys

Pazarlı

Alaca Höyük

Maşat Höyük

Boğazköy

Eskiyapar

Kerkenes Dağ

Alişar

Sultanhan Höyük

Kululu

Kültepe

Karahöyük

Malatya

Acemhöyük *

Göllüdağ

Konya

Tepebağları *

Niğde

Ivriz

Porsuk

Tarsus

Karatepe

Zincirli

Carchemish

Til Barsip

Tell Halaf

Khorsabad *

Nimrud *

Orontes

AMUQ

Euphrates

Tigris

Arslan

Gordion

Polatli

Van

