

PUBLICATIONS OF THE JOINT EXPEDITION OF THE BRITISH MUSEUM AND OF  
THE MUSEUM OF THE UNIVERSITY OF PENNSYLVANIA TO MESOPOTAMIA

# UR EXCAVATIONS

VOLUME IV

## THE EARLY PERIODS

A REPORT ON THE SITES AND OBJECTS  
PRIOR IN DATE TO THE THIRD DYNASTY  
OF UR DISCOVERED IN THE COURSE OF  
THE EXCAVATIONS

By

SIR LEONARD WOOLLEY, M. A., D. LITT.,  
LL.D., HON. A. R. I. B. A., F. S. A.

PUBLISHED FOR  
THE TRUSTEES OF THE TWO MUSEUMS  
BY THE AID OF A GRANT FROM  
THE JOHNSON FUND OF  
THE AMERICAN PHILOSOPHICAL SOCIETY  
PHILADELPHIA

1955

*Sold in Great Britain at*  
THE BRITISH MUSEUM  
*and in the United States of America at*  
THE UNIVERSITY MUSEUM  
PHILADELPHIA

PRINTED IN  
THE UNITED STATES OF AMERICA  
AT ALLEN, LANE & SCOTT  
PHILADELPHIA

## FOREWORD

This volume was completed and made ready for printing in 1935. The delay in its appearance is due in the first place to precedence having been given to Volume V, dealing with the Ziggurat, in the second place to the war, and since then to the economic difficulties in which the war has involved scientific institutions. It is now published as originally written except for a few omissions justified by the advance of knowledge in the light of more recent discoveries.

The bulk of the material here dealt with was obtained in the seasons 1928 to 1934. Throughout the whole time I had the assistance of my wife, for three seasons Mr. M. E. Mallowan was the chief archaeological assistant, and as subordinate members of the staff I had in different seasons Mr. P. J. Railton, Mr. R. P. Ross-Williamson, Mr. F. L. W. Richardson and Mr. P. D. Murray-Thriepland; Messrs. A. S. Whitburn, J. C. Ross and A. F. E. Gott were the architects and the Rev. E. Burrows, S. J. and Mr. Chauncey Winckworth in turn the epigraphists. Throughout the whole time Hammoudi of Jerablus was my head foreman and was assisted by his sons Yahia (who was also photographer to the Expedition) and Alawi. To all of these I wish to express my gratitude for their unfailing help; although I am solely responsible for the actual text of this volume the work which it enshrines is as much theirs as mine. Further, whatever merits of accuracy in detail the book may possess are due to the care and patience of Miss Joan Joshua, than whom I could not have found a more conscientious helper for the analytical and statistical work which is its essential part.



## TABLE OF CONTENTS

CHAPTER I. THE SEQUENCE OF PERIODS . . . . .	page 1
The evidence for the prehistoric periods. The discovery of the Flood stratum. Stratification. Test pits. The classification of the periods.	
CHAPTER II. THE AL 'UBAID PERIOD . . . . .	page 7
Part I: Al 'Ubaid I. House remains. Pottery and flints. Absence of metal. Mereijib. The formation of the delta. The primitive culture. Cone mosaics. Clay figurines. Small objects. Al 'Ubaid the oldest culture.	
Part II: The Flood. The historical bearings of its identification. The Flood and the King-lists. Its possible causes.	
Part III: Al 'Ubaid II and III. Two series of graves. The graves of al 'Ubaid II. Position of bodies. Pottery. The graves of al 'Ubaid III. Cultural changes. The decay of al 'Ubaid and the intrusion of Uruk.	
CHAPTER III. THE URUK AND JAMDAT NASR PERIODS . . . . .	page 23
Uruk pottery. Jamdat Nasr pottery. Jamdat Nasr graves at Ur. Analysis of pottery contents of the graves; association and relative dating. Stone vases. The decorated ware. The evidence of stratification. The Uruk period. Building. The potter's wheel. Cement. The Jamdat Nasr period. Buildings. Length of time. Glazed ware. Metal work. Stonework. Carved vessels. The wild boar. Inlaid mace-head. Reliefs. Writing. Seals and seal-impressions. Burial customs.	
CHAPTER IV. THE EARLY DYNASTIC PERIOD . . . . .	page 34
Part I: The Plano-convex Brick period. The violent end of Jamdat Nasr. Plano-convex bricks. The Ziggurat of Ur. Reserved slip and other pottery fabrics. The second cemetery at al 'Ubaid. Links with the Uruk period. The early part of the period. The Royal Cemetery, further graves. A military cemetery. Stone statue. Decorated pins. The First Dynasty of Ur. The Ziggurat. Dedication-bowls. "Apsu" drains. Objects.	
Part II: The Lagashite age. Inscriptions. Libation-plaque. Ur-Nina stela. Lagashite domination of Ur. Smaller monuments. Statue of Entemena.	
CHAPTER V. THE SARGONID PERIOD . . . . .	page 49
The disk of Sargon's daughter. Sargonid graves. Cylinder seals. Indus valley connections. Rimush. Manishtusu. Naram-Sin. Renewed Lagashite control. Ur-Bau. Gudea. Examples of stone carving. The accession of Ur-Nammu.	
APPENDIX I. DETAILED DESCRIPTION OF THE EXCAVATED SITES . . . . .	page 54
APPENDIX II. DETAILED DESCRIPTION OF THE GRAVES OF THE AL 'UBAID PERIOD . . . . .	page 87
APPENDIX III. TABULAR ANALYSIS OF THE GRAVES OF THE JAMDAT NASR PERIOD . . . . .	page 103
APPENDIX IV. TABULAR ANALYSIS OF THE GRAVES OF	
(a) The Royal Cemetery period found in Pit X. . . . .	page 127
(b) The Sargonid period . . . . .	page 134
APPENDIX V. NOTES ON AND EVIDENCE FOR THE DATING OF	
(a) Pottery of the al 'Ubaid period . . . . .	page 146
(b) Pottery of the Uruk and Jamdat Nasr periods . . . . .	page 148
(c) Stone vessels of the Uruk and Jamdat Nasr periods . . . . .	page 155
APPENDIX VI. CHEMICAL ANALYSIS OF	
(a) Cement . . . . .	page 158
(b) Bitumen . . . . .	page 158
(c) Metal . . . . .	page 164
(d) Flood deposit . . . . .	page 165
APPENDIX VII. CATALOGUE OF OBJECTS . . . . .	page 167
INDEX . . . . .	page 221

## LIST OF PLATES

- PLATE 1. Plan of the Temenos enclosure, showing early sites, position of pits, etc.
- PLATE 2. (a) Pit F; soil stratification.  
(b) Pit F; drainage system of second level.  
(c) Pit F; buttressed wall of the third level.  
(d) Pit F; deposit of clay cups at the bottom of a "drain" shaft.
- PLATE 3. (a) Pit F; wall of mud bricks laid herring-bone fashion.  
(b) Pit F; "reserved slip" pottery *in situ*.  
(c) Pit F; a kiln with its batch of pots inside.
- PLATE 4. (a) Pit F; potter's basin of cement bricks.  
(b) Pit F; work at the 8.00 m. level.  
(c) Pit F; an al 'Ubaid III burial, PFG/D.
- PLATE 5. (a)-(f) al 'Ubaid burials in Pit F.
- PLATE 6. (a), (b) and (c) Pit F; al 'Ubaid burials.  
(d) Pit F; brick construction below the Flood deposit.
- PLATE 7. (a) Pit X; initial stages with Neo-Babylonian ruins.  
(b) Pit X; clay coffins below the Kassite houses.  
(c) Pit X; a Sargonid brick-lined tomb.  
(d) Pit X; a Sargonid grave with a bitumen boat.
- PLATE 8. (a) Pit X; the pit completed, showing levels.  
(b) Pit X; a Jamdat Nasr burial, JNG/325.  
(c) Pit X; a cut below the Jamdat Nasr burials into the Flood deposit.  
(d) Pit Y; Grave JNG/361 showing the typical contracted position of the body.
- PLATE 9. (a) Pit W; clay bowls inverted above the Jamdat Nasr burials.  
(b) Pit X; Grave JNG/188 with a bowl inverted over it.  
(c) Pit X; Grave JNG/204.  
(d) Pit X; the lowest stratum of Jamdat Nasr graves.
- PLATE 10. (a) Pit W; showing strata SIS 5-6 and the Flood deposit.  
(b) Site EH; general view.  
(c) Pit K; a wall with mixed bricks, plano-convex and flat.  
(d) Site EH; drains of Third and First Dynasties.
- PLATE 11. (a) Site EH; a First Dynasty room with drain openings.  
(b) Site EH; a First Dynasty bath with outflow pipe.  
(c) Site EH; an Early Dynastic drain with trumpet pipes.  
(d) Site EH; an unusually large trumpet drain-pipe.
- PLATE 12. Stone weapons and implements from Ur and Reijibeh.
- PLATE 13. Stone weapons and implements.
- PLATE 14. Stone celts, etc.
- PLATE 15. Small objects in stone, bone and clay.
- PLATE 16. Small pottery objects.
- PLATES 17-19. Painted pottery of the al 'Ubaid period.
- PLATE 20. Clay "goddess" figures of the al 'Ubaid period.
- PLATES 21-24. Clay figurines, human and animal, of the al 'Ubaid and Uruk periods.
- PLATE 25. Decorated pottery of the Uruk period.
- PLATE 26. Decorated pottery of the Jamdat Nasr period.
- PLATE 27. Jamdat Nasr beads and amulets of mixed dates.
- PLATE 28. Amulets of mixed dates and carnelian beads with bleached patterns.

- PLATE 29. Copper objects of Royal Cemetery period and bull's hoofs from SIS 4-5.
- PLATE 30. Metal objects.
- PLATES 31-34. Stone vases from the Jamdat Nasr graves.
- PLATES 35,36. Decorated stone vessels.
- PLATE 37. (a) Alabaster statuette from a Royal Cemetery grave.  
(b) Steatite figure of a wild boar, Jamdat Nasr date.
- PLATE 38. Stone carvings and engraved shell of First Dynasty date.
- PLATE 39. (a), (b) Stone figures for inlay.  
(c) Limestone votive plaque of the Lagash period.  
(d) Granite stela of Ur-Nina.
- PLATE 40. Diorite statue of Entemena.
- PLATE 41. (a) Fragment of archaic inscribed stela.  
(b) Fragment of archaic inscribed stela.  
(c) Diorite statue of Dada-ilum.  
(d) The disk of Sargon's daughter.  
(e) Alabaster figure of a lion.
- PLATE 42. Stone sculpture down to the time of Gudea.
- PLATE 43. Two heads, (a) in diorite (b) in alabaster, perhaps of the time of the Third Dynasty of Ur.
- PLATE 44. Various objects in shell, stone and terra-cotta.
- PLATE 45. Store-jars, drains and clay model tools.
- PLATES 46-50. Patterns found on al 'Ubaid I painted pottery.
- PLATES 51-53. Types of al 'Ubaid pottery.
- PLATES 54,55. Field sketches of Jamdat Nasr graves.
- PLATES 56-64. Types of Jamdat Nasr pottery.
- PLATES 65-67. Types of Jamdat Nasr stone vessels.
- PLATE 68. Pottery types (additional) of the Royal Cemetery and Sargonid periods.
- PLATE 69. (a) Metal vase types of Jamdat Nasr and Royal Cemetery date.  
(b) Stone vessel types (additional) of the Royal Cemetery and Sargonid periods.
- PLATE 70. Site EH; plan.
- PLATE 71. Site EH; section showing relation to Pit F.
- PLATE 72. Section in the Royal Cemetery area showing the position of Pits A-E and G.
- PLATE 73. Pit F; section.
- PLATES 74,75. Pit F; plans of the successive building strata.
- PLATE 76. Pits K and L.
- PLATE 77. Pit W; section.
- PLATE 78. Pit X; section.
- PLATES 79-81. Pit X; cemetery plans.
- PLATE 82. Pits Y and Z.
- PLATE 83. Comparative sections of all the pits.





## CHAPTER I

### THE SEQUENCE OF PERIODS

The title of this volume, "The Early Periods," is meant to comprise all the stages of South Mesopotamian history which antedate the founding of the Third Dynasty of Ur in the twenty-second century B.C.; the book will deal with all the objects of those periods unearthed by the Joint Expedition in so far as they have not been adequately treated in the volumes of this series already published.<sup>1</sup> The material is arranged in the accepted order of periods,

- I. The al 'Ubaid Period.
- II. The Uruk Period.
- III. The Jamdat Nasr Period.
- IV. The Plano-convex Brick Period (now generally known as the Early Dynastic Period).
- V. The Sargonid Period. With this is included the relatively short period leading up to the establishment of the Third Dynasty.

This classification, which is the basis whereon Sumerian history has to be written, is not as the individual names shew, the result of any one excavation, nor is it likely that any single site should give a fair picture of all the periods so classified; the findings and the conclusions of each excavator have to be checked and supplemented by those of his colleagues—for instance, the al 'Ubaid period has not as yet been recorded at Kish, and the work at Ur would not have given us any inkling of the importance of the Uruk period as proved by the magnificent discoveries at Warka. If therefore in the following chapters I refer to results obtained on other sites it is in order to present my own discoveries in a truer perspective; and if I emphasise a point on which the evidence from Ur seems to conflict with that obtained elsewhere it

<sup>1</sup>Vol. I, *Al 'Ubaid*; Vol. II, *The Royal Cemetery*; Vol. III, *The Archaic Seal-Impressions*; Vol. X, *The Cylinder Seals*.

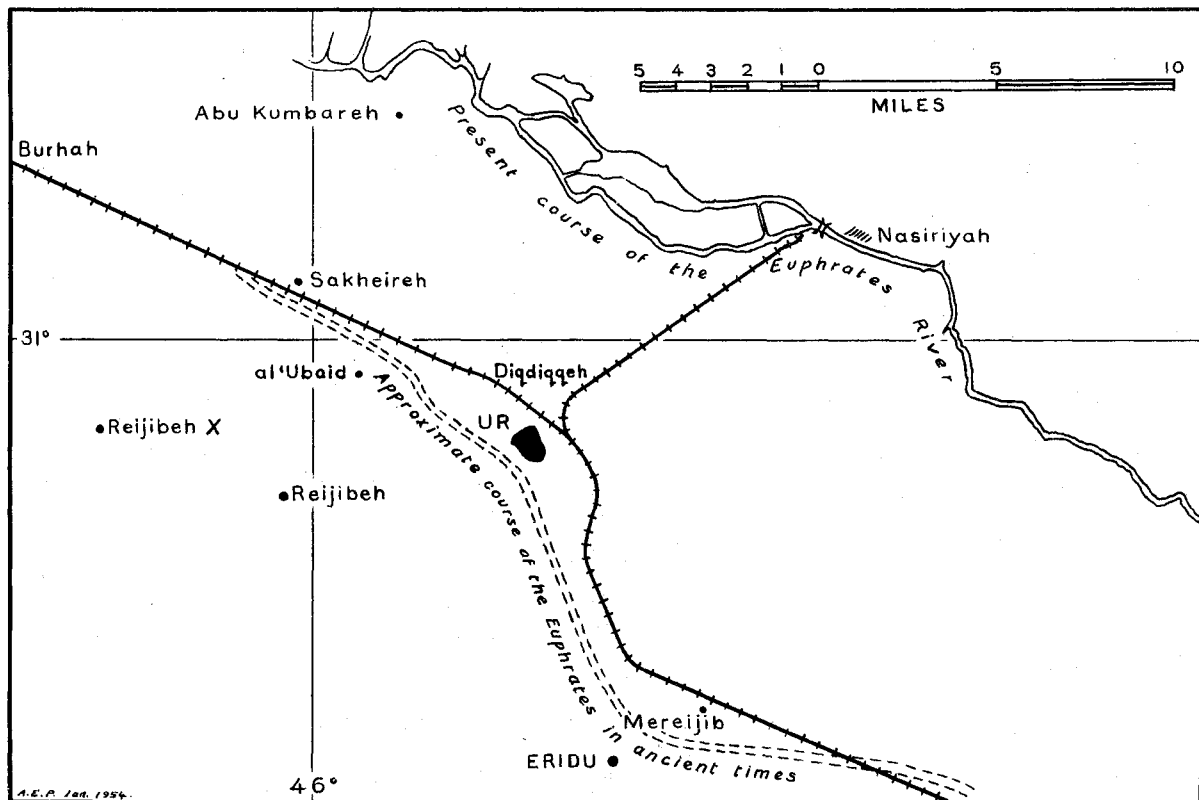

Fig. 1. Sketch Map of the Ur District

is because the final conclusion must be one that reconciles both facts and does not disregard either. The accepted sequence lays down the main lines of history applicable to all sites. In the light of the Ur discoveries some further distinction seems possible; accordingly I here subdivide the al 'Ubaid period into al 'Ubaid I, II and III, and the Plano-convex Brick Period into five phases (A) The "Reserved slip ware" phase, (B) The phase of the Clay Goblet (Type JN.25), (C) The Royal Cemetery period, (D) The First Dynasty of Ur, and (E) The Lagash period down to the reign of Entemena. These subdivisions certainly correspond to the conditions observable on the site, but I make no claim that they are final for archaeology in general.

With the discovery of the Royal Cemetery we were definitely committed to the investigation of the archaic levels. It was obvious that behind the sophisticated art illustrated by those graves there must have been centuries of progress from whatever was the primitive culture of the first inhabitants of the river valley, and to trace such development was an urgent duty.

The nature and stratification of the soil shewed that the graves had been dug into rubbish-mounds built up from the refuse of the town; the mounds were necessarily older than the graves. The graves lay so high above the general level of the plain beyond the town as to make it obvious that there must be lower and earlier deposits undisturbed by the grave-diggers. Consequently in the season of 1928-9 a series of small shafts or trial-pits were sunk in that part of the cemetery area in which the excavation of the graves was complete so as to test the nature of the underlying strata.

The result of the first pit was dramatic.<sup>1</sup> Starting at the level of the floor of the Great Death-pit, PG/1237, the workmen dug through the normal rubbish of the cemetery area, the grey mud of decomposed crude bricks, broken pottery, household refuse and builders' rubbish; but a metre and a half down this changed, quite suddenly, to perfectly clean clayey sand; apart from a fragment of fossilised bone which had certainly no archaeological interest there was nothing whatsoever to be found and after digging vainly for a metre or so the men announced that they were in virgin soil: an inspection of the pit seemed to confirm this and a stop was put to the work. When I was writing my notes on the shaft a serious difficulty occurred to me. "Virgin soil" had been found at 6.90 m. above sea level; the railway station of Ur Junction is only 4.30 m. above sea level and the plain on which it stands has of course, risen since the early days when it was part of the deltaic marsh; our "virgin soil" would therefore have been an island at least five metres high, a very commanding eminence in the flat marsh land. I had always assumed that the earliest settlers had taken advantage of islands for their settlements, but such would be low, and would have to be raised artificially or even in part created by the making of reed platforms similar to that described in the Creation legend and to those made by the marsh Arabs today; if a natural island five metres high had existed it would have certainly been used for buildings – but we had found no trace of buildings – and that it should have been naturally formed at all seemed improbable. If the facts seemed to contradict my theory the only hope for the theory lay in testing the facts, so I sent the men back into the shaft and told them to continue digging in spite of appearances. It certainly seemed hopeless, for the clean sand went on until the men had reached a point 5.20 m. below the floor of the death-pit; then suddenly the entire character of the excavation changed and they were digging into mixed refuse, ashes and decomposed brick, containing masses of potsherds of the familiar al 'Ubaid type; at two metres above sea level there came another change, to yellow sandy soil containing only a very little pottery, and ten centimetres below that sandy soil which was absolutely clean; we dug into it for a metre without finding any trace of human activity, and since it had every appearance of being purely natural and we were now less than a metre above sea level, at which point human occupation was scarcely possible, I decided that we had this time reached real virgin soil and could stop the work.

An examination of the great sandy belt through which we had dug shewed that it was water-laid; it could only be the result of an inundation, and that on a very great scale; I was convinced that we had found material evidence of the Flood recorded by the Sumerian King-lists and described in the Flood legend; my wife came independently to the same conclusion and the other members of my staff were convinced of its accuracy: it was a startling but a satisfactory conclusion. What was more immediately to the point was that we had gone far to establish the relative chronology of the al 'Ubaid pottery; it had been found on virgin soil, so that in this particular spot there was nothing older to be found, it underlay not only the Royal Cemetery but all the masses of rubbish which had accumulated before the graves of that cemetery were dug, and it underlay the deposit of silt which seemed to correspond with an actual event recorded by Sumerian writers as having occurred in the history of their country at a time so remote as to be well-nigh fabulous; so far as present evidence went it was the oldest pottery in the country.

Another small trial-pit (Appendix I, Pit A) dug in the neighbourhood of the first gave similar results; there was the same bed of silt with the al 'Ubaid culture below it, and a fresh touch was added by our finding in that bottom stratum a properly made kiln-fired brick, not round-topped as were the bricks of the al 'Ubaid temple and of the tomb-chambers in the Royal Cemetery but flat and of measurements which we had never found before; isolated though it was, it was enough to prove that the "pre-Flood" age was

<sup>1</sup>See Appendix II, Pit B.

sufficiently advanced in culture to construct houses of moulded bricks. A third pit (Appendix I, Pit G) which was not carried down to anything like the same depth, was of much interest because in it other types of painted ware occurred, a buff or pink ware with bands of dull red paint, a ware entirely covered with a wash of plum red, sometimes brilliantly burnished, and sherds of the regular Jamdat Nasr pottery with its rich three-colour decoration; with these were found a small number of clay tablets inscribed with a script which was definitely earlier in type than that of inscriptions from the Royal Cemetery, and seal impressions also of an archaic character. The stratification was not well defined, a failure not uncommon where rubbish-heaps are concerned, but in spite of a certain amount of confusion it was clear that the al 'Ubaid pottery when it did appear belonged on the whole to levels lower and older than those in which the other types were found. The appearance of Jamdat Nasr pottery was particularly welcome because it proved that the ware was not confined to the northern region of Kish but had its vogue also in the south, thus making correlation between the two sites possible, and coming where it did, it tended to shew, though the evidence was not yet conclusive, that it succeeded the al 'Ubaid ware and was perhaps its immediate successor.

These results had been obtained from small trial-pits; the evidence which such could give was very local, very partial and as proof for any far-reaching theory inconclusive. Accordingly in the following season 1929-30 an excavation (Pit F, Pl. 73) was planned on a large scale which should confirm or refute the witness of our small pits. The site chosen was inside the limits of the late Temenos or Sacred Area of Ur and therefore likely to be within the limits even of the earliest town, for we wished to avoid the mixed rubbish-heaps already familiar to us and the disturbed area of the cemeteries and to work through a stratification assured by superimposed buildings: in order to get our results as expeditiously as possible we selected a spot where denudation by wind and rain had caused the disappearance of all structures of the historical periods and had reduced the modern ground surface to about the level of that of the third millennium B.C.: in a former season, excavating in higher ground to the SE, we had found walls built of plano-convex bricks and therefore not much later than the First Dynasty of Ur which were denuded away when they came to the face of the slope but had once continued across the area now chosen at a level well above the existing surface:<sup>1</sup> assuming for those walls a date early in the third millennium, we could be sure that the highest and latest buildings which we might find under the surface would be rather older than that date. Our supposition was proved correct by the discoveries made in the course of the work. Starting at ground level a number of seepage drains were found, drains formed of earthenware rings with small holes in their sides set one on another, column-fashion, in a circular pit sunk in the soil; the space between the drain-pipes and the earth sides of the pit was packed with broken pottery which prevented the holes in the pipes from being blocked by earth and so allowed the water poured down the pipes to escape freely into the subsoil. Pottery types are our main dating evidence and even fragments can often be identified; the potsherds packed round any drain might have been collected from anywhere and might include early specimens, but they were more likely to be contemporary, and at any rate the latest example that could be identified must give a *terminus post quem* for the construction of the drain; a few of the drains in question were of the time of the Third Dynasty of Ur, many more were approximately of First Dynasty date. Since all of them were broken away at the ground surface they must have served houses which, through denudation, have disappeared. We have dug hundreds such at Ur and can say that while they differ much they are seldom less than four metres and never less than three metres in length; when then we find (e.g., in Sq. D8 on plan A, Pl. 74) First Dynasty drains broken at ground level and penetrating less than three metres into the soil, we can be sure that the floor containing their intake was at least a metre above the modern surface; in short, above the topmost building in our excavation there must have been at least one and probably two buildings (now represented only by the drains) of which the latest could not be much later than the First Dynasty of Ur: our topmost building then ought to be considerably earlier than that dynasty.

Further evidence confirmed this. A full account of the pit is given in Appendix II, and here only the points required for the present argument need be summarised. Starting from the surface there were found eight successive levels of buildings most of which were characterised by the pottery which they contained: in the first three levels certainly and perhaps in the first four (the fourth level did not give conclusive evidence) the pottery is the same in type as that found in the graves of the Royal Cemetery. That cemetery therefore and these building strata must be contemporary. I had already, on other grounds, dated the Royal Cemetery as coming well before the First Dynasty of Ur, and that *terminus ante quem* is supported by the new evidence; further, in view of the fact that three, or four, phases of construction each of which, judging by the solidity of the buildings, should represent a reasonable length of time, all fall within the Royal Cemetery period, something between two and three centuries does not seem an exaggerated estimate for the latter's *floruit*.

With the fifth building level there was a definite change. A great deal of pottery was found on the floors of this range and it was of a sort never occurring in the Royal Cemetery but familiar to us from graves at al 'Ubaid and also, in fragmentary examples, from the pits already dug under the cemetery area; the most

<sup>1</sup>See the section, Pl. 71.

characteristic ware was the "reserved slip ware,"<sup>1</sup> the peculiarity of which is that the vessel after being finished on the wheel and dried was dipped in or washed over with a slip made of a clay finer in texture and generally lighter in colour than the body of the pot, and then with the finger or with a rag the slip was wiped off in streaks; thereby the surface of the vessel is diversified by alternate narrow bands of light and dark, the dark being the coarser body-clay, the light the finer slip raised in very low relief. Other wares found on the fifth-floor level were decorated with incised hatching or with a bolder "gashed" ornament deeply cut with a knife-edge; and sharply-defined shoulders of spouted jars were often emphasised by a band of cable-pattern in relief. The vogue of the "reserved slip" ware introduces a certain cross-division into our sequence of periods. It is fairly common in the Jamdat Nasr Period and the stratification of our pit proves that it disappears before the time of the Royal Cemetery, but the fact that it was found freely on the floors of buildings constructed with plano-convex bricks shews that it overlaps into an early phase of that same main period which includes the Royal Cemetery as well as the First Dynasty of Ur.

With the sixth building level we are taken out of that period altogether, for the walls here (as in the seventh and eighth levels) are built with bricks which are not plano-convex but flat. It was long supposed that the curious cake-shaped brick, rounded on the top, which we call plano-convex, was typical of the oldest Sumerian civilisation. At Jamdat Nasr in 1925-6 the pictographic tablets were found in buildings constructed with small flat-topped rectangular bricks, and at Warka in 1929-30 flat-topped bricks were found underlying the plano-convex strata; we have had to revise the old view and now recognise the plano-convex brick as the distinguishing feature of a period long and important but relatively late in Sumerian history.

Reserved slip ware persisted through the sixth stratum and into the seventh; but in the seventh stratum the vast preponderance of the clay vessels were of the type JN.25, a very thin-walled goblet, curiously unpractical in that its elongated foot is too small to allow of its standing up, thousands of these, represented by complete examples or by fragments, must have been found in the building, and not a single specimen was recorded either from the level immediately above or from that immediately below. The phenomenon might seem to be accidental but for the fact that the type occurs also in one small stratum only in Pit Z (*v.* Appendix I, p. 79) and that at Kish it has been found also in great numbers in a single stratum (five to six metres below plain level) which in its relation to the reserved slip ware on the one side and to Jamdat Nasr pottery on the other corresponds exactly to what we have at Ur. We are therefore justified in regarding the goblet type as characteristic of a short and quite definite sub-period.

In the seventh building level one or two fragments of Jamdat Nasr pottery appeared and several examples of plain burnished red ware or ware covered with an unburnished wash of deep plum-red paint; ribbon handles also occurred. In the eighth building level the same types were more common and there were also examples of vessels of light clay decorated with bands of red paint.

Below this level the stratification by buildings failed us and the huge accumulation of pottery "wasters" from the kilns whose ruins were buried in the mass gave far less regular and satisfactory evidence, but general results are still clear. Down to ten metres above sea level the plain red-painted wares and those with red lines on a light ground are common, but there is none of the three-coloured Jamdat Nasr pottery; between the ten- and nine-metre levels Jamdat Nasr ware was comparatively common; between nine metres and eight metres fifty, less abundant; below the eight-fifty level it disappeared altogether. As the work went down below the ten-metre level the plain red or plum-coloured wares and those with red bands on a light ground continued to appear in large numbers, handled vases were common, burnished pots fairly so, and below the nine metre level came fragments of finely burnished black pottery; gradually the black-on-buff or black-on-green al 'Ubaid pottery, at first very rare, grew more ordinary until at level 5.50 m., the bottom of the deposit of "wasters" from the kilns, it was found almost to the exclusion of the other painted and decorated wares. The succession is thus quite clear.

Below the kiln stratum came the bed of silt which we had expected to find when we began to dig the pit: it was three and a half metres thick, duly water-laid and necessarily clean in itself; but into it a number of graves had been dug, some of them from the level at which the kiln "wasters" began, others apparently (though this was not certain) from a temporary surface-level a metre lower which seemed to imply that a second inundation had followed the first after a short interval of time. Whether or not the graves had indeed been dug from different levels they did form two groups distinguished from each other by their depth in the soil and also by the nature of their contents: all were of the al 'Ubaid type and belonged to the representatives of that cultural phase who inhabited Ur after the inundation, but, whereas those of the upper tier contained never more than one painted vessel and that a cup whose ornament was confined to simple bands of black paint, and in nearly every case had one or more examples of the plain pedestal bowl Type aU. 9, in the graves of the lower tier the pedestal bowl was unknown and the painted vessels were numerous and their decoration much more elaborate. Here there was manifest evidence of the decay and gradual extinction of the al 'Ubaid culture. Underneath the bed of silt, resting on the dried surface of the original marsh, we found remains of huts and houses and in and around them innumerable sherds all of the al 'Ubaid type, and amongst them many which were of the extremely thin ware with rich decoration extending over the whole

<sup>1</sup>A good example is shewn in *Ur Excavations*, Vol. I, Pl. LIV, b, the left-hand figure.

surface characteristic of the surface finds at al 'Ubaid itself. The oldest examples of the ware therefore seem to be the best and most ornamental; these belong to the pre-Flood age; after the Flood comes a period of degeneration which we can conveniently divide into two phases represented by our graves. To these subdivisions we can give the names al 'Ubaid I, II and III; they are consecutive and merge one into the other, and it is not by any means always possible to attribute to one of them rather than to another any al 'Ubaid sherd found without context, for simple decoration may occur in al 'Ubaid I although elaborate ornament is unknown in al 'Ubaid III; to differentiate al 'Ubaid II is particularly difficult: none the less the time sequence with its corresponding modification of design is real and of value. It should be noted that our material illustrates disconnected points or phases in that sequence. Between the graves of al 'Ubaid II and those of al 'Ubaid III there is a considerable lapse of time, enough to allow of profound modifications in the pottery types; between the al 'Ubaid II graves and the pre-Flood settlement there was also a lapse which may have been of some length. The actual process of degeneration was probably much more uniform than the sporadic evidence from Ur would suggest.

While this excavation was in progress another piece of work equally important for the chronology of the site was being carried out in the Royal Cemetery area. In the south corner of this area there was found underneath the graves of the Sargonid period a sharply-sloping stratum of rubbish, largely composed of lime rubble and broken pottery, which starting at the top as two distinct layers separated by a belt of dark-coloured rubbish and ashes became after a short space one single stratum running downhill to the south-east and, with a less pronounced fall, to the north-east; it had at one time been the surface of the irregular mound formed by the rubbish dumped in this open space within the bounds of the city. A similar stratum had been observed to overlie the greater part of the cemetery; it was not by any means always composed of the same materials – a little further away to the north-east it was grey, of decomposed mud brick; but it was the same stratum and must have corresponded to some phase of destruction in the town. At the point now under consideration the lime rubble probably came from the ruin of a temple store-house, for mixed with the innumerable fragments of broken store-jars were fragments of the mud stoppers with which they had been covered; many of these bore the impressions of the seals with which they had been stamped, and amongst the seal-impressions were some with the name and title of Mes-anni-padda, the founder of the First Dynasty of Ur. This dated the stratum. Allowing for the probability that the jars were stored for some time before they were destroyed, and the destruction need not have taken place in Mes-anni-padda's reign, yet the rubbish must have been thrown here not later than the end of the First Dynasty (and we must notice that the seal-impressions bore the name of no later ruler) and more probably during that dynasty; incidentally between its deposit and the reign of Sargon there had to be time for the accumulation above it of such a depth of fresh rubbish that the Sargonid graves could be dug into it without reaching the Mes-anni-padda level. Since the stratum spread unbroken over the Royal Cemetery, the latest of that cemetery's graves must be earlier in date than it and for the cemetery as a whole we are given a definite *terminus ante quem*.

On the section, Pl. 82, the Mes-anni-padda stratum is labelled SIS 1 and SIS 2. Below them comes a thick bed of mixed rubbish in which are found all the graves of the Royal Cemetery; below this again are strata, once more clearly defined, labelled SIS 4 and SIS 5. The lowest of the graves touched or were cut down into a stratum of rubbish which on the line of the section and for a considerable distance to the SW of it was coloured a deep red, being composed of burnt brick earth; further to the NE it was sooty black; in it were found quantities of clay tablets inscribed with a script very much earlier in character than that of the royal graves, and clay jar-stoppers bearing seal-impressions; it was a deposit not unlike that of the First Dynasty, but of a very different date. The archaic texts (*Ur Texts*, Vol. II) stand in point of development half-way between the Fara texts and the pictographic tablets of Jamdat Nasr; the seal-impressions (*Ur Excavations*, Vol. III) form a striking contrast to those from SIS 1 and 2 and in not a few cases bear inscriptions which are purely hieroglyphic.

Again it must be remarked that the stratum SIS 4-5 must be considerably older even than the earliest graves of the Royal Cemetery, because after it was formed there had to be time for the soil and rubbish to accumulate in which those graves were dug, and as a grave-shaft might be more than eight metres in depth (e.g. PG/1236) and few of them came so deep as this red deposit the accumulation was great and should represent a fair lapse of years. On the other hand the seal-impressions and the tablets, all flung out together when their use was past or when the building in which they had been kept was destroyed, might have been already old and can quite well have been contemporary with the strata immediately below them in the ground-rubbish which had been dumped here while they were preserved in store; that is at least a possibility.

In the NW part of the excavation (Pit Z) where the underlying strata were undisturbed there were found examples of the clay goblet JN.25 which characterised a definite level in Pit F, and sherds of reserved slip ware. At the SE end, Pit Y, the stratum SIS 4-5 had itself been cut through in one or two places and in any case the soil below it had been disturbed by grave diggers; most of the graves had been dug before the stratum was formed, while one or two apparently were later in date than it. For three or four metres' depth the ground was thick with burials. We had come on a new cemetery quite distinct from the Royal Cemetery of the upper levels; the attitude of the bodies was not the same, the offerings placed in the graves

with them were all of new types; and they were not uniform among themselves. In the upper graves there were examples of reserved slip ware; others produced pots with bands or very simple patterns done in red paint on a background of buff or greenish clay; others had pots painted red all over, sometimes left matt but more often finely burnished, or pots of grey or grey-black ware, made in the smother-kiln, also burnished; and at the bottom of all came graves with the typical Jamdat Nasr vases painted with geometrical patterns in three colours. In Pit Z a few graves of the later types were found at much the same level as in Pit Y; underneath them, at about a metre and a half above sea level, there was a single grave of the al 'Ubaid class distinguished by the possession of an unusually fine and boldly painted example of a spouted "tea-pot," Pl. 19, U. 14988. The soil in which the Jamdat Nasr graves were dug was full of al 'Ubaid potsherds, in Pit Y as well as in Pit Z; such sherds went down through mud and black organic soil and were found finally lying on the clayey bottom of the pre-settlement marsh.

Again therefore we have here a long sequence which is in complete accord with that given by Pit F and, in a less detailed manner, by Pit G and the other smaller pits dug by us (See Pl. 83). Later excavations carried out in the same area (Pits W and X, Appendix I) simply confirmed these results; in them however, was more evident the heavy bed of silt left by the Flood: it overlay the earliest al 'Ubaid remains and the earlier graves of the Jamdat Nasr series were dug into it.

Meanwhile at Kish M. Watelin had dug through a cemetery which was in part of the same type and date as our Royal Cemetery at Ur and in part rather earlier and below it had found a stratum containing numerous examples of the clay goblet type JN.25, a stratum containing sherds of "reserved slip" ware, and then one with the three-coloured Jamdat Nasr pottery; below this again he found flint implements and examples of plain burnished pottery resting on virgin soil. Of the al 'Ubaid period there was no trace at Kish in those parts of the site at present excavated. In Warka below the Jamdat Nasr level come buildings in which the characteristic pottery is plain burnished red or black, and behind this comes the al 'Ubaid pottery which continues down to virgin soil. On three different sites therefore, where good serial stratification was secured the results were absolutely concordant.

## CHAPTER II

## THE AL 'UBAID PERIOD

## Part I: Al 'Ubaid I

On the strength of the evidence available we can assert that the al 'Ubaid culture was that of the earliest inhabitants of Ur. Our chief source of information is Pit F (Appendix I, p. 56) dug in 1929-30. Here we found, below sea level, the stiff clay which was the bottom of the primitive marsh; in the clay could be discerned the discolouration due to the decay of the roots of plants and lying on the clay was a thick bed of black organic soil composed of decayed vegetable matter—the stems and leaves of the reeds which grew in the shallow water. At the bottom of the black stratum, and only at the bottom, there were sherds of painted al 'Ubaid pottery, all lying horizontally; clearly these had been thrown out from houses near by and had sunk in the mud, finding their level and lying flat as sherds in such a case are bound to do. The surface of the mud, a little above sea level, was desiccated and gravelly in texture, shewing that the rising marsh had become dry land; on this was an irregular but fairly thick stratum of house remains and refuse. At one point three distinct clay floors, superimposed, proved a certain length of occupation, but the ruins were scanty and no ground-plans of buildings could be made out, but of the character of the buildings there was evidence enough. At one end of the pit was a short length of fallen wall built of bricks set in mud mortar (Pl. 6,d); they were fired to a deep red-brown colour and had all the appearance of kiln-made bricks, but a closer examination shewed that the mortar also was burnt to a deep red, so that the whole building must have suffered from fire; it is possible that the bricks were already kiln-fired, though if so the firing had been on the light side, but it is practically certain that the wall had been of crude mud bricks and that the whole effect of their having been kiln-fired was due to accidental burning. On the other hand in Pit A (Appendix I, p. 54) there was found at a corresponding level, underneath the Flood deposit, an unquestionable example of a kiln-fired brick, so that in this early period, as throughout all subsequent Sumerian history, the two types of brick, the kiln-fired and the crude, were regularly used at the same time for different requirements.

Across the SE end of Pit F ran a low mound of red and black clay; much of it had amalgamated with time and damp into a formless mass but out of it we were able to extract lumps which kept their shape and explained their character. The lumps were always smooth on one side, sometimes flat, sometimes curved, and that side was invariably bright red; the other side was carbonised black and was deeply corrugated; the sections of two such (Fig. 2) will serve better than a description to illustrate their appearance, though it must be remarked that no two were exactly alike and the curve on the smooth red side was sometimes concave, as drawn, but occasionally convex; the edges were in all cases broken and jagged; in the corrugations could be seen the imprint of the fibrous stems of reeds. It was obvious that this was the clay plaster that had been applied to the sides of a hut built of reeds precisely as reed huts are built in Lower Iraq today, with upright ribs made of reed fascines and either a covering of mats or, as in this case, panels of reed-stems planted upright and held together by lacing. Our reed hut had been destroyed by fire and the heat of the burning reeds, which had carbonised the inner face of the clay and baked it red throughout, had so hardened it that the fragments, flaking away, had preserved the exact texture which the builders had imposed upon them. It was inevitable that reed-and-daub construction, common in Iraq nowadays, should have been as old as man in the Euphrates valley where once all was mud and reed-beds; we had found similar remains at al 'Ubaid, and had no material evidence been forthcoming to support a natural argument we have the Flood legend wherein the god Ea, anxious to save Uta-napishtim yet afraid to betray to a man the secret of the gods, whispers it to the wall of the house saying "Reed-hut, reed-hut, hearken." What is illuminating is the varied form of the plaster fragments, flat and convex and concave; it means that the walls, in this case, were not plain but relieved by mouldings which, since the plaster adheres to and follows the reeds, were truly constructional; so far from disguising the structural features of his building the architect emphasises them in his facing material. To some extent we can vis-

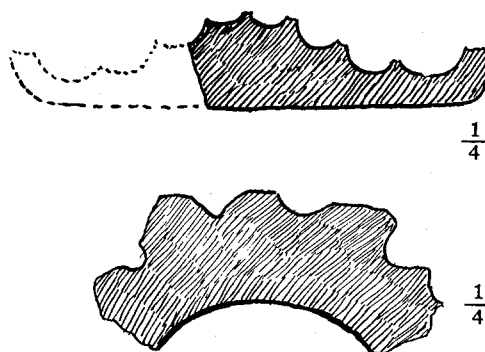

Fig. 2.

ualise the effect (Fig. 3). The fascines forming the main uprights would appear as half-columns; the cross ties necessary when screens of upright stems are used instead of matting, which would themselves be reeds tied in bundles, would appear as horizontal mouldings framing the flat panels of the screens; here

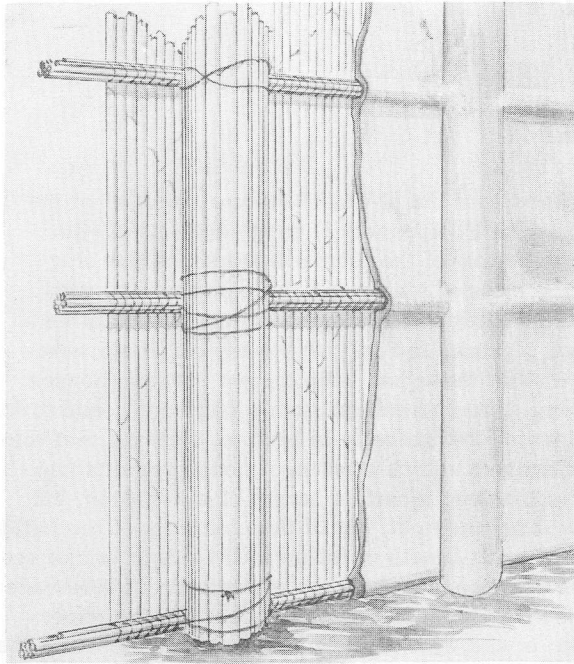

Fig. 3.

the mud was rounded off in a bold curve: the general appearance would be not unlike that of the familiar temple of later Sumerian times with its half-columns or recesses, the translation into brickwork of a style natural to timber construction. Building with reeds is but a cheaper form of building in wood, just as daub or *pisé de terre* is a cheap substitute for brick; in outward appearance the brick house and the reed hut of the al 'Ubaid age may have looked very much the same. It was probably due to religious conservatism that in later times the temple architect laid stress on structural lines which were really quite alien to his material; the al 'Ubaid builder, achieving perhaps a not dissimilar effect, was moved by a truer architectural sense when he emphasised in his plaster the ribs and ties of his real framework.

The occupation stratum in which these ruins occurred was very rich in domestic remains. Most common of course, was pottery. All was of the al 'Ubaid type. The plain vessels were of very light-coloured drab clay, generally with thin walls and skilfully turned, either purely hand-made or made on a slow wheel which would revolve no faster than the movement of the hand (i.e., it was not weighted and so could turn on its axis but did not go on spinning with its own momentum); many of the pots were spouted and a fair proportion had

loop handles across the mouth, but there were no vertical reeded handles. Of the decorated pottery the larger vessels with thick walls were sometimes of pinkish drab clay with designs in chocolate brown, but black paint on greenish drab was more common and in the case of the smaller vessels of thinner ware was almost invariable; the pigment and the clay are probably the same in the two types and the differences due to inequalities in firing; not infrequently the design on a single pot will grade off in colour from black to reddish brown, and such variations are more likely to occur when in different pots the thickness of the clay varies greatly, and it is also possible that large vessels would as a rule be placed in a different part of the kiln and so be subjected to different conditions of heat. I doubt whether it is wise to stress too strongly the distinction between the brown-on-pink and the black-on-drab or black-on-green wares. On the sherds collected from this stratum there was a noticeable tendency for the ornament to be spread lavishly over the whole surface; on the smaller vessels such as the cups the design was often intricate, as in the best sherds from al 'Ubaid, and on the larger it was bold and free, plant motives being not uncommon (v. Pl. 47, Nos. 5-11), and it was at this level that we found examples of the very rare animal motives (Pl. 47, Nos. 1-4). This tendency was even more marked in the case of the sherds found under the occupation stratum at the bottom of the black marsh mud.

Stone pounders and grinders were numerous; flint hoes (*cf.* Pl. 12, c) were common and there were also polished celts (*cf.* Pl. 14) and flakes, tooth-edged or plain, of flint and obsidian (Pl. 12, b); with them were clay sickles, net-sinkers<sup>1</sup> clay models of tools, a fragment of a finely-polished vase in black and white marble, clay "bent nails," clay spindle-whorls, two lumps of bitumen shewing the imprint of basket-work (probably of the baskets in which the bitumen was imported from the wells), beads of shell and steatite and two of amazonite, a stone the nearest known source for which is the Nilgiri hills of central India, though it is found in Transbaikalia also, and some specimens of the slender clay cones used for wall mosaics; further there were fragments of clay figurines, U.15349 and U.15603, Pl. 22 and crudely modelled animal figures. There was no trace of metal. In Pit L (Appendix I, p. 74) there was found a strip of worked gold at a level corresponding to the occupation-level in Pit F, but hitherto we have discovered no

<sup>1</sup>These are of two forms; either plain rings of baked clay about ten centimetres in diameter, or thick clay disks perforated with two holes, both near one edge and fairly close together, Fig. 4. At Mereijib we found (*v.* Appendix I, p. 82) a large number of the latter type tied together with string, but I was unable to detect their use; at Khafaje a quantity of the ring type have been found by Preusser fastened to the actual remains of nets (*Oriental Institute Communications*, No. 13, p. 92). I have no doubt that both types served the same purpose.



evidence of copper-work coming before the Flood. My first impression was that the clay models of tools shewn on Pl. 16 (U.14993 and U.14985) were derived from metal originals, but this is not necessarily the case, and their prototypes may have been stone (*cf.* the stone axe U.14990 on Pl. 14); on the other hand a model clay axe of al 'Ubaid painted ware with hollow socket and splayed blade, found at Ur by Taylor (Pl. 16, L.B.M. 56.9.8.136) is, as Professor Gordon Childe has pointed out,<sup>1</sup> in view of its form undoubtedly derived from a metal original. At Warka no metal has been recorded from the lower al 'Ubaid levels. At Ur in the late al 'Ubaid graves dating from soon after the Flood and in the occupation-levels of the same date copper objects do occur. Mr. Sidney Smith<sup>2</sup> points out that the name of one of the pre-Flood cities given by the King-lists, Bad-tibira, means "the Wall of the Copper-smiths" and suggests that the tradition may represent a historical fact and that men already used copper when they first came into the alluvial plain. Personally I should be inclined to accept that view, but it cannot be said to be proved by the material evidence; so far as that is concerned we can say definitely that the sub-periods al 'Ubaid II and III enjoyed a chalcolithic culture combining the use of stone and copper, but of al 'Ubaid I that only in the latter part of it at any rate are there signs of copper having been worked and it may have started and for the greater part of its time remained neolithic. But it must be remembered that the available evidence is purely negative and therefore unsatisfactory. The abundance of stone implements and clay tools does prove that metal, if it were known at all, was rare; it would be of value and therefore one is less likely to find examples of it overlooked or thrown away in house ruins; it would probably be used chiefly for small objects, and although a knife would be jealously guarded a needle might well be dropped and the chances of a copper needle surviving or indeed of its leaving in the soil any recognisable trace of itself are relatively slight. At Warka in a pit sunk to virgin soil it was only in the al 'Ubaid II stratum that worked copper was found, and then only one isolated specimen, yet we know from the al 'Ubaid III graves at Ur that copper was regularly used at the time; if then in the ten metres' depth of accumulated deposit representing at Warka the al 'Ubaid I period there was a complete dearth of metal, it may, as Dr. Jordan suggests,<sup>3</sup> be due to the accidents of discovery rather than to the character of the culture. When in summarising his results Jordan states categorically that the earliest al 'Ubaid settlers were ignorant of the use of metal<sup>4</sup> he may or may not be right; it is certainly true to say that if metal was known to them it was extremely rare at the beginning and only came gradually into common use; most of the dwellers in the reed huts must have been content with implements of clay or stone.

Actually at Ur we are not in a position to say much about the beginnings of the al 'Ubaid period because it is not properly represented by the excavations. Our earliest house and hut remains were built on the surface of a marsh which had gradually dried; fragments of pottery were found lying at the bottom of that marsh, thrown away while it was still soft mud and water and therefore older than our huts; I have already remarked that the tendency to richness of decoration was more strongly marked on those fragments than on the sherds from the ruins. In the pits dug to the east and south-east of Pit F scattered remains dating to the al 'Ubaid period were found beneath the Flood deposit but there were no houses — no trace of actual residence on those spots but only such debris as would accumulate round a village, and in Pits Y and X such seemed to have accumulated on or in damp soil. Everything goes to shew that our Pit F has hit the outskirts of the settlement, land which was yet marsh when the first immigrants arrived and was only used for building long afterwards when it had had time to dry. There are other grounds for adopting this view. At Warka the lowest remains are platforms made of bundles of reeds laid flat and covered with clay, the sort of platforms that are still made in the marshes of lower Iraq to raise the marsh-dweller's hut above the level of the waters, the sort of platforms of which the Creation Legend speaks, "Marduk laid a rush mat upon the face of the waters, he mixed up earth and moulded it upon the rush mat, to enable the gods to dwell in the place where they fain would be."<sup>5</sup> At Ur the houses are set upon soil which has dried naturally, but is only a little above sea level. Either the first comers to Ur found an island ready for their

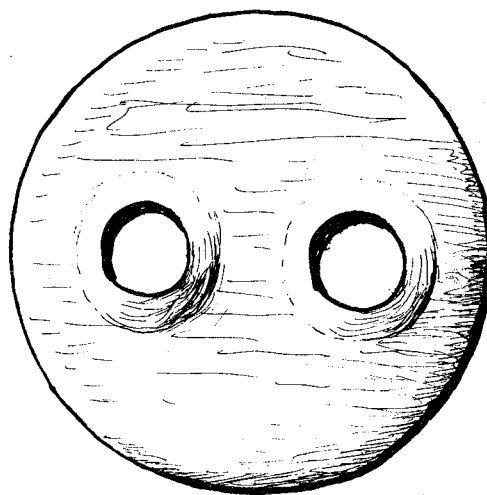

Fig. 4. Scale  $\frac{4}{5}$ .

<sup>1</sup> *Eurasia Septentrionalis Antiqua* IX, p. 159.

<sup>2</sup> *Early History of Assyria*, p. 24.

<sup>3</sup> *Abhandlungen der Preussischen Akademie der Wissenschaften*, Phil.-Hist. Klasse, 1932, No. 2, p. 30.

<sup>4</sup> *Loc. cit.*, p. 35.

<sup>5</sup> Translation in *The Babylonian Legends of the Creation*, published by the British Museum, 1921.

use or they built an artificial platform in its stead, and in time their site must have attained a considerable elevation. That it did so is shown by the very high level at which the foundations of the plano-convex brick buildings occur on the site EH and by the height of the al 'Ubaid rubbish-mounds, which must have been heaped against the walls of the town, in Pit Z; also by the thickness of the Flood deposit, piled up by the waters against the obstruction of the town mound, already therefore of some height, as well as by the fact that though the houses found by us were buried under the silt of the Flood a large part of the inhabitants must have survived the disaster, which would point to their dwellings having been above its reach. The houses in Pit F had been destroyed by fire, not by water, but the silt lay directly on and round them, so they must have been the last to occupy the site before this fresh disaster came; they belong then to the end of the al 'Ubaid I period, and the three superimposed floors which we found at the other end of the pit would not stand for any very long interval of time. The ten metres of continuous accretion at Warka (where the excavation was in the middle of the town site) must correspond to a lapse of centuries, for us at Ur represented only by the potsherds lying at the bottom of the marsh. Had we dug our pit some fifty metres away to the south-west we should, I fancy, have found no trace at all of the flood deposit but should have dug through continuous strata of al 'Ubaid culture similar to those found at Warka: as it is, the results of one excavation must be checked wherever possible by those of others if a true picture is to be obtained. On our own shewing, the whole al 'Ubaid I period might have been reduced to a few generations of men; in the light of Warka we can see it as occupying hundreds of years.

A further aspect is afforded by an outlying site in the Ur district. Towards the end of the season 1931-2 some Arabs brought me in a few flint hoes and polished celts; encouraged by the *baksheesh* they received they brought in more a few days later; when asked where the stones were found they declared that it was at Reijibeh, a site which I had visited several times, some six miles SSW of Ur, and knew to be predominantly at least, of the date of the Third Dynasty of Ur and an unlikely spot for flints. As time went on more and more stone implements were brought, sometimes as many as fifty at once, and the rewards diminished in proportion; when the men saw that there was little more to be made out of their discovery they became more communicative and admitted that the site was not Reijibeh itself but a place for which the Arabs had no name at all, some six miles further away; and they agreed to guide me to it. The place proved to be about twelve miles from Ur and to the north-west of it<sup>1</sup> where there is a long and shallow depression in the desert, now a waste of loose sand hills and camel-thorn bushes but once either a river channel or a belt of marsh running into the land: in the middle of it rose a mound about a hundred metres in diameter and rather less than two metres high the entire surface of which was covered with al 'Ubaid pottery, flint hoes, flakes, celts, pounders and grind-stones, clay sickles and all the debris of a prehistoric village; most typical was the clay figurine U.18169, Pl. 21. Certainly there was there nothing later in date than al 'Ubaid, and so far as I could see (I had to judge by what was visible, for there was no opportunity of undertaking excavations there) all the remains were on the surface and digging would have produced little or nothing; in short, the settlement had been on a mound rather higher than the mound is at present, it had been deserted in the al 'Ubaid period, and judging from the type of pottery during the sub-period al 'Ubaid I; it had never been re-occupied, and denudation by wind and rain had resulted in the lowering of the mound to below occupation level, the light soil being carried away and the heavier objects left *in situ* until the mass of them formed a covering over the whole site. This occupation of an island site which must have been the case at Ur and is fully illustrated by what we called, for want of a better name, Reijibeh X, has other parallels. At al 'Ubaid itself the primitive settlement was on a natural island<sup>2</sup> and again denudation had brought its remains close to the modern surface in spite of the fact that they had once been buried beneath later buildings.<sup>3</sup> About ten miles to the south of Ur, at a spot close to the modern railway line called by the Arabs Mereijib,<sup>4</sup> we excavated what was left of an early village. There had been an al 'Ubaid settlement, but this was represented only by potsherds, a post-Flood occupation having destroyed all other traces of it: but under a platform of mud bricks which had been laid as a foundation for the later buildings we found the clean sand of a natural island rising perhaps a metre above the ground level of today and therefore some five metres above sea level—obviously a tempting site for the earliest immigrants and one of which they had not failed to take advantage.

<sup>1</sup>The compass-bearings were approximately, Ur 45°, Abu Shahrein 110°. See the sketch-map, Fig. 1.

<sup>2</sup>*Ur Excavations*, Vol. I, p. 149.

<sup>3</sup>Some of the facts reported from al 'Ubaid have to be reinterpreted in the light of subsequent knowledge. A sunken hearth lined with *plano-convex* bricks, being found in the level of the hut remains, was assigned to the same period, which seemed natural enough when the plano-convex brick was believed to be the oldest type in Mesopotamia, but now it is sure proof of later occupation: I remarked that in the trench across the hut site "the distribution of the pottery was curious," one end yielding comparatively few painted sherds but masses of coarser black and grey ware combed decoration and the other end a preponderance of painted wares and very few examples of the combed; now we know that these wares are not of the same date, and their association (so far as it goes) is due to the denudation of the mound which had obliterated all stratification.

<sup>4</sup>This is a generic name, from the same root as Reijibeh, and merely means a hillock. See the sketch-map, Fig. 1, and for detailed account Appendix I, p. 82.

We can now picture something of what the land was like when these immigrants arrived. Much of it was still marsh dense with reeds and opening out here and there into lagoons or clear channels through which the slow river made its way to the sea, but along the edges and scattered about over the marshland were higher patches rising clear of the normal level of the waters, and wherever this was so, the earth, a rich mixture of alluvial soil and vegetable mould, shewed itself amazingly fertile, bringing forth, from the moment that it became dry ground, "grass and herb yielding seed and fruit-tree bearing fruit after its kind"; and rarely breaking the flat line of the horizon were island knolls on which men might make their homes. And this was true over a vast area. In the far north, clear of the limits of the delta, at Nineveh<sup>1</sup> and Arpachiyah,<sup>2</sup> the characteristic al 'Ubaid pottery is occasionally found mixed with northern wares and overlying thick strata composed of the debris of an earlier age; but in the alluvial plain it is found on a vast number of early sites and, as has been shewn, marks the beginning of the occupation of those sites by man: in short, the settlement of all these sites was more or less simultaneous. This can only be explained by the manner in which the land was made fit for settlement. The Mesopotamian delta was not formed, as deltas often are, by the slow advance of the land at the river's mouth. The Tigris and the Euphrates emptied into a long arm of the sea which at one time ran inland as far as the rock beaches of Hit; they brought down vast quantities of silt, but it has been shewn that the normal scouring of the Gulf tide is enough to carry that silt out into the ocean. But into the same arm of the sea emptied, from the east the Karun river, whose burden of silt is as great as that of the Tigris and Euphrates combined, and opposite to it was another river, now the dried Wadi al Batn, which in its long course through Arabia must also have collected masses of silt to drop into the Gulf. The deposit from these two rivers in time formed something of a bar across the gulf and thereby prevented the scouring action of the tide in the northern section; the Tigris and the Euphrates now dropped into a lagoon all the alluvium they had brought down from their upper reaches so that while a delta formed in the normal fashion in the north the whole of what had been sea tended to fill up, and the deposits of the Karun and the Wadi al Batn, spreading inwards from the bar, enabled the growth of land in the south to keep pace with that in the north. Had the process been the same as goes on today, for instance, in southern Iraq, where the delta of the joint rivers is pushed forward regularly from north to south at the rate of a mile and a half in every hundred years, ancient Mesopotamia would have been colonised gradually from the north southwards, the advance taking advantage of the extension of the land, and the southern colonies would therefore have been very many centuries later in date than those of the north which so far as we can see is not the case: the settlements took place within the limits of a single archaeological period. All through history, and up to the present day, there were districts in which the process was never completed, marshes which have never dried; but over the greater part of the land the alluvium rose more or less consistently and the sodden reed-beds gave place to dry ground in the south as in the north and everywhere at one and the same time a newly-created earth held out its invitation to the immigrant.

It was a country rich enough in promise to make a certain amount of hardship well worth while. Every year the rise of the river drowned much of the higher land, increasing its fertility but adding to the discomforts of life: to be out of the reach of water houses had to be built on artificial platforms of reeds and mud, and drainage canals had to be dug to dry the soil betimes for cultivation and to reclaim new land; later, fresh canals had to be cut to irrigate the soil reclaimed. The vast number of flint hoes that strew the old sites, the sickles of hard-baked clay (poor utensils which nevertheless could be used, but were often replaced by sickles of flint flakes set with bitumen in wooden holders) and the net-sinkers of clay or stone bear witness to the manner of life of the early husbandmen and fisher folk: but in judging their culture we must remember that even the few remains of it we possess do imply something more than the circumscribed poverty which they seem to illustrate. Rich as the land was its wealth was wholly agricultural and everything apart from that of which the people had need was imported; flints indeed could be picked up on the high desert of the west, but diorite, obsidian, marble, gold, carnelian, steatite, even the haematite with which they painted their pottery, all had to be brought in from abroad, and when we find beads of amazonite, coming from so far away as central India, we have evidence of a commerce strangely at variance with the seeming simplicity of the primitive village. In the latter part of the period al 'Ubaid I there was in lower Mesopotamia a community leading a well-organised life dependent in the first place indeed on farming, centred on its fertile soil, but none the less in close touch with a wider world. The very nature of their land, its need of such work of irrigation and drainage as could only be achieved by common action, imposed on them a certain measure of social unity; from the beginning they seem to have been town-dwellers and the concentration which was in any case enforced by the opportunity of the island sites had developed the growth of cities many of which were destined to endure for thousands of years: the King-lists, shadowy and fantastic as they are, imply that according to the traditions current in later times the social system of the pre-Flood age had evolved the idea of sovereignty as representative of god's power on earth and had effected a union of the scattered cities under a common overlord: loose as the tie might be—and even in his-

<sup>1</sup>R. Campbell Thompson, "The Excavations on the Temple of Nabu at Nineveh" in *Archaeologia*, LXXIX, p. 136.

<sup>2</sup>M. E. L. Mallowan, "Excavations at Tall Arpachiyah, 1933" in *Iraq*, Vol. II, 1 (April, 1935).

toric times it held ill—it speaks of a national spirit and of a society already complex.

Nor do the remains, scanty though they are, fail to bear witness to the more sophisticated side of life. I have spoken of the burnt bricks as witness to buildings of a permanent nature and with some architectural pretensions, but we can go further than that. In the occupation stratum there were found, as there are often found associated with al 'Ubaid pottery, the small clay cones, pencil-like and often painted at the blunt end (Pl. 15, U.17985) which we know to have been used for mosaics decorating the surfaces of walls; with them too are the curious "bent nails" of baked clay whose use is still a matter of doubt but which I believe to be also intended for wall decoration. Already then at this time there was practised the art which we shall see in all its glory in the buildings of the Uruk period at Warka, and the temples of pre-Flood Ur must have been gay with polychrome designs masking the mud plaster of their walls. If the extraordinary Anu-Ziggurat of Warka,<sup>1</sup> built of mud and bitumen and ornamented with rows of clay pots inset in its walls, dates from this period—and it certainly cannot be later than al 'Ubaid III—then we have an actual illustration of the ambitious works undertaken by a government able to dispose of mass labour and an example of the manner in which the people did honour to their gods.

The mention of religion brings us to the subject of the astonishing clay figurines illustrated on Plates 20-23. The best examples of these were found in the graves of the sub-period al 'Ubaid II, but some, e.g., U.15349 and U.15603, came from the occupation level and U.18169 from Reijibeh X and so prove that the type is common to al 'Ubaid I: they can therefore best be treated here.

Most of the figures are female. These are always represented as nude though bands of paint round waists, wrists and neck may represent belts, bangles and necklaces; there is never any hint of dress. They stand upright, and either the arms are by the sides and the hands resting on the body above the hips, or they are holding an infant to the breast. The bodies are slender to the point of exaggeration and well modelled, with small but prominent breasts and the pudenda conventionally emphasised; the shoulders are unnaturally wide and angular, and on them and on the upper arms there are either spots of black paint or small lumps of clay applied, undoubtedly to represent tattoo-marks, the tattooing being done either in colour, as by the modern Arab of Syria and Iraq or by cicatrices as by tribes in Arabia and Egypt. To the bodies, which are by no means unpleasing, the heads are in striking contrast. The top of the skull rises in an elongated dome (in the case of the infant in U.15376, Pl. 20, this is flattened into a fan shape) which was originally covered with bitumen to represent hair; in several cases the bitumen is more or less preserved, in one, U.15399 (Pl. 22), the shape is rather different and the bitumen is replaced by black paint.<sup>2</sup> The rest of the head, unduly large, is absolutely reptilian in character, coming forward to a blunt snout, flat above, with great slit-like eyes emphasised by lids in relief, which are set at a sharp slant; the nostrils are mere holes on either side of the snout and there are no ears. Two heads differ from the rest; U.15398, (Pl. 22) found in the lowest occupation level, and U.15516 (Pl. 22), from the al 'Ubaid II grave QQ, had indeed the same dome-like skull (it is broken away in the case of U.15516) but the face instead of being pointed is broad and flat, the nose is a human nose and the mouth and chin, especially of U.15516, are definitely human and in the latter figure the eyes are not so grotesquely large while in both they are set horizontally instead of obliquely; of U.15398 the face was painted bright red and the tall skull has two bands of black paint instead of being covered all over with hair.

Male figures of the al 'Ubaid I period are rare; several have been found at Warka but from Ur we have only one isolated example, CBS 17199 on Pl. 21. Here the head is crudely shaped by pinching the clay and the body also is very roughly formed; the left hand is raised to the face and the right arm brought across the body; the figure has a long straight beard which hangs down over the chest; body and beard alike are marked by horizontal bands of black paint. It will be seen that the male figure offers a marked contrast to the female figures whose delicate modelling has been described above so much so indeed that it would seem to belong to an altogether different category and to have more in common with the animal figurines; the technique is the same, there is the same impressionistic treatment and the same use of paint. Nothing that has been said about the female figures applies justly to the male and the arguments based on the style of "goddess" terra-cottas would find no support in the style of the male figures.

Together with the human figures there are found those of animals, sometimes painted, more often plain, all crudely modelled in clay. It is not easy in all cases to identify the animals intended to be represented by these rough little figures, but the pig, the ox and the buffalo are recognisable, and in others a very little imagination will see the sheep, the goat and the dog. Painted animal figures are peculiar to the al 'Ubaid period, as are the human figures of the types described above; but in the succeeding ages and right down to the Third Dynasty of Ur very similar crude figures of animals and even cruder images of men commonly occur; even when figures of a much more pretentious sort cast in moulds, baked and coloured, had long been in vogue, the primitive clay figurines, either plain or embellished with applied strips and pellets of clay in the "snow-man" technique, continued to find their public. It is extraordinarily difficult to date

<sup>1</sup>Jordan, in *Abhandlungen der Preussischen Akademie der Wissenschaften*, Phil.-Hist. Klasse, No. 4, p. 20, Pls. 8, 17.

<sup>2</sup>The figure resembles rather one from al 'Ubaid, T. O. 405. *Ur Excavations*, Vol. I, Pl. XLVIII.

by style any isolated example of an art so simple and so conservative, and apart from the evidence given by the conditions of discovery there is seldom justification for assigning such to any particular period, nor indeed is it very important to do so. In the plates at the end of this volume the examples found under the Flood deposit and those distinguished by having their details rendered in the typical al 'Ubaid paint are grouped together; the find-spots of the rest are given in the general catalogue.

In my preliminary publication of the figurines from Pit F<sup>1</sup> I gave it as my opinion that the grotesqueness of the female figures was deliberate and that the subject was some kind of half-human demon; "That the figures have a religious significance is certain, and if they really represent a bestial type their importance as documents for the pre-Flood religion is even greater." This view has been stigmatised as a misleading anachronism,<sup>2</sup> but I think unjustly. The animals are certainly not toys, they are votive, as is proved by the fact that later examples are found bearing inscriptions (Cf. U.18390, U.18391, Pl. 21, (and as such possess a religious significance) and it is not possible to dissociate them altogether from the human figures with which they are found. As regards the latter, that they do possess a religious significance is evident from the fact that they were placed in graves. Had they been merely dolls put there for the amusement of the dead or for sentimental reasons we should expect to find in the graves other objects that could be similarly explained such as weapons, gaming-boards, etc., none of which are actually found; they must be votive and therefore have some kind of magic or religious value. To have settled that does not however solve the question whether they represent human men and women or gods and goddesses: the moulded terra-cottas of the late historic ages, which we can fairly take to be the direct descendants of our prehistoric figurines, portray sometimes divinities, made manifest by their attributes, and sometimes their human devotees; so far as analogies go therefore the archaic prototypes could as well be the one as the other. I am still convinced that the artist who could so well model the human body could have made a far better success of the human face, had he wished to do so, than appears from these lizard-like grotesques. It is true that on seals, even as late as the time of the Royal Cemetery, the human face is made to look like the head and beak of a bird, but that is due not to any artistic convention but to technical limitations;—working with tubular drill and chisel on a hard material and on a very small scale the obvious thing was to drill a round hole for the head and gouge out a triangular projection for the salient feature, the nose. But the worker in clay had a freer hand and could really do with his material what he wished; neither artistic convention nor lack of skill did in fact prevent him, from abandoning when he chose, the reptilian model and producing something as different as U.15516. It does seem then that the particular type adopted, and very skilfully carried out, in the majority of our figurines, U.15385 (Pl. 20) etc., was adopted deliberately, and certainly it was not selected as best representing the women of the time. What then was the object? In later Sumerian art the mixture of human and animal elements in one divine is usual enough, and that is the sort of thing which generally is derived from primitive origins.<sup>3</sup> It is no anachronism to argue back from the known to the unknown when tradition is reasonably consistent and the past presents phenomena which cannot otherwise be explained: I still hold that we have in these figurines a deliberate intention to represent something which was not merely human, and that this has an important bearing on the religion of the earliest inhabitants of Mesopotamia.

A remarkable head of a vulture carved in diorite, U.18210, Pl. 27, was found on the surface at al 'Ubaid; it is certainly archaic but whether it belongs to the al 'Ubaid period it is certainly impossible to say—if it does, it is our only example of carving in stone of the period. Very common on the other hand are the studs of which typical examples are shewn on Pl. 15, U.16603 and 17764; they are sometimes of baked pottery, more often of steatite or other stone, including obsidian, well shaped and finely polished: presumably they are ear-studs. The nail-shaped objects illustrated at the top of the same plate have not been satisfactorily explained; the coarse example U.2806 is of bitumen, U.14970 is of shell, U.2573 (a variant in shape) is of white calcite and the rest are of obsidian, generally very well cut and polished: they may be pins for fastening a dress. The steatite palette, U.17972 on Pl. 15, is one of a pair from Reijibeh X. On Pl. 27 are shewn two curious clay beads or amulets, U.18588-9, found below the Flood silt in Pit W; the design is carved in the clay after baking and stands out in bold relief. From Reijibeh X came the decorated spindle-whorl U.18194 on Pl. 16. The clay object U. 17825, Pl. 16, on which there is painted in black what seems to be a replica of itself I take to be a votive copy of a weaver's comb; occasionally there are found clay sickles decorated with painted bands, and these too may possibly be votive.

<sup>1</sup>A. J. X. 4. p. 338.

<sup>2</sup>Jordan, *op. cit.*, p. 28.

<sup>3</sup>An omen-text states that a child born with a head like a serpent is an omen sent by Ningizzida (Jastrow, *Die Religion Babyloniens und Assyriens*, II, 900). More to the point is it that Ningizzida himself can be represented with a human head and a body covered with scales, or again with snakes instead of legs; (Frankfort in *Iraq*, I, 1, p. 9 and Pl. IIa). The snake is indeed a regular attribute of Ningizzida as a god of the Underworld (E. D. van Buren, in *Iraq*, I, 1, p. 65ff.). In this connection it is perhaps worth noting that only the female figurines (in which the reptilian character is much more strongly marked) have hitherto been found in graves and that in one instance only (PFG/QQ) was the figurine of a non-reptilian type (U.15516, Pl. 22). The association of the figures with the dead and the fact that they normally present features emblematic of the gods of the Underworld support the view that they are chthonic deities.

Of the stone implements the most characteristic are the hoes (Pl. 12,c) of which the triangular type is not uncommon but the spoon-shaped type is by far the most common; the broad end usually shows signs of use, so that it is clear that the long pointed end was employed for hafting and that the implements really are hoes. They are especially numerous at the site Reijibeh X and can, I think, be definitely classed as an early al 'Ubaid type, most common in al 'Ubaid I and rarely found in or after al 'Ubaid II. Of the small flint or obsidian blades of which examples are shown on Pl. 12,b, while it can be said that the obsidian specimens are for the most part early it would be more than rash to try to give any general date. They are found at all levels. In the case of the blades it is common to find on both edges and the ends of them have in some cases transverse retouch; since when they were set for use only one edge was exposed (*cf.* Pl. 13, U.14920) this can only mean that they were often re-used.<sup>1</sup> Normally all these blades would be classed as sickle-blades, intended to be set in a row along the edge of a sickle of wood or bone or perhaps clay. The majority of the clay sickles of the al 'Ubaid period were not provided with flint edges but were used as they are, and as they are very numerous the need for flint sickle-edges would not appear to have been very great, yet the flints are numerous both in that period and afterwards when clay sickles had long gone out of fashion and metal was in free use. I think that very many of the flints were used not in the harvest-field for sickles but on the threshing-floor and that they were set in the wooden *tribulum* (the flat wooden sledge with flints set in its under surface) which is certainly a prehistoric invention and is still used in Mesopotamia and in Syria; in that case they may be of any date.<sup>2</sup> Of the arrow-heads it is worth noting that the triangular chisel-edged type (Pl. 13, U.17723) occurs at Reijibeh X and should therefore belong to al 'Ubaid I, but a complete set of them were found in the grave of Mes-kalam-dug (*Ur Excavations*, Vol. II, p. 160), so that the type enjoyed a very long vogue. It has been extremely difficult to get evidence for the date of the leaf-shaped and barbed types, some examples of which are very finely worked (Pl. 12,a). A few do come from Reijibeh X and from definitely early levels, but the vast majority have no satisfactory horizon and so many are found in levels of the Third Dynasty and later that

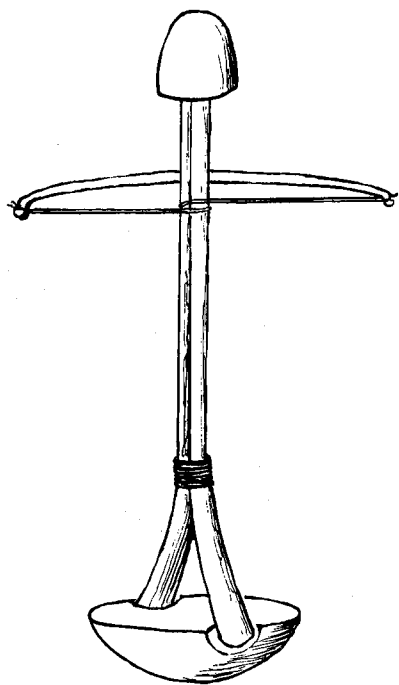

Fig. 5

the average of testimony is inconclusive but it is hard to avoid the conclusion that for one reason or another flint arrow-heads were used until a relatively late stage. The polished celts were found in considerable numbers at Reijibeh X and a few came from the lower levels at Ur; the occurrence of such in definitely late strata may be due to their being valued as charms. The stone borers for hollowing stone vases (U.16405 on Pl. 13) are common in the Uruk and Jamdat Nasr periods; the drill-point is a circular stone flat on the top and curved underneath, and from each side a piece is cut out for attachment; the shaft of the drill would be made of two pieces of wood laid together (or one piece forked at one end) used as in the sketch, Fig. 5; this gripped the stone drill-head and was revolved by a bow, the top being held in a cupped stone handle (U.14925, Pl. 15)<sup>3</sup>.

Generally speaking there is not a wide range of forms in the stone implements from Ur (there are few types shown here which had not been previously published in *Ur Excavations*, Vol. I, Pls. XIII and XIV) and this is perhaps the strongest argument that we have in favour of all the archaic periods, even al 'Ubaid I, being chalcolithic rather than purely neolithic. It is true that no metal (other than gold) has yet been found in al 'Ubaid I, but in an advanced neolithic culture one would have expected a greater variety of specialised stone implements. Apart from the likelihood of metal objects having perished it must be remembered that most of the al 'Ubaid I sites as yet investigated have been very poor, not of the sort to produce much in the way of metal if metal was still a comparatively expensive rarity.

<sup>1</sup>For these remarks I am indebted to Miss Dorothy Garrod, who adds "in the Early Bronze Age in Palestine we get sickle-blades made from broken-off lengths of a larger flint blade, and although they are not denticulated both edges are apt to be worn and lustrous. I think that the only explanation is that when one edge of the blade was worn it was reversed in the haft."

<sup>2</sup>We have an instance of an obsidian flake with denticulated edges being found in a grave of the Early Dynastic period and apparently carried (in a pouch?) suspended from a man's belt (*Ur Excavations*, Vol. II, p. 160, PG/780); what it was used for cannot be said.

<sup>3</sup>An unfinished bowl of grey steatite, U.18754, illustrated the process of manufacture. The outside has been very roughly shaped. The inside has been gouged out with a chisel whose blade was 0.006 m. wide — the tool-marks are well preserved. The next stage would be to use the grinder to complete the roughly-made hollow, and the outside would be finished only when the more difficult work of the inside was safely accomplished. This is the method with soft stone such as steatite; with the harder stones there would be no chisel work and the hollow would be produced entirely by grinding.

## Part II: The Flood

The comparative table published on Pl. 83 of the pits dug by us at various points down to or nearly to sea level shews that in nearly every case we encountered a heavy belt of clean water-laid soil overlying the al'Ubad I stratum. In pits Y and Z it is absent; in pits K and L it is present but there is a greater admixture of rubbish; in pits A, B, F, W and X it is very marked; in pit C a darker mud replaces the sandy clay of the main deposit, and there is more stratification. The reason for such differences will be made clear later; for the moment the cases where it is present concern us more than those in which it is lacking.

As to the character of the stratum there can be no question; it is silt deposited by water action, and that all at one time, for there is none of the lamination caused by intermittent action interrupted by intervals of dryness: only in pit F is there a possible temporary surface dividing the deposit into two parts, but even this cannot be traced over the whole area and, allowing that it be a true surface and mark an interruption of the flood to which the whole mass must be due, the lower deposit none the less attains the respectable thickness of between 2.50 m. and 3.50 m., according to the height of the ruins which it covers; above the suggested temporary surface comes another metre of silt of precisely the same nature. The only person who ever did doubt the character of the material was M. Watelin, who visited the site before Pit F was dug and could base his opinion only on the evidence of the small pits A and B; he took away some of the silt and published<sup>1</sup> an analysis of it made in the laboratory of the Physical Geography section of the Sorbonne which proves that it is fresh-water silt containing just those elements which are to be expected from the waters of the Euphrates. A microscopic analysis by the Petrographical Department of the Geological Survey, Jermyn Street<sup>2</sup> confirmed the riverine origin of the material. In Pit F the deposit has an average depth of three and a half metres, in Pit B it measures 3.70 m. in thickness, in Pit A, 2.70 m., and in Pits W and X the upper part has been disturbed too much by later grave-diggers for any accurate measure to be taken, but it would seem to have totalled not less than two and not more than three metres and a half. So vast a mass of silt laid at one time could only be the result of a very great flood.

The analysis shews that the flood was, primarily at least, the Euphrates. That river rises in flood annually, but it would of course be idle to maintain that we have here evidence only of its normal inundation; a flood which piled three metres and more of mud over the ruins of the houses in which men had been living was no normal and annual event; in no subsequent stratum do we find evidence of anything like this disaster. A great amount of silt is at all times carried by the Euphrates and is increased where the river rises with the melting of the snow in Asia Minor; most of it is borne down by the current to the Persian Gulf and in the ordinary way the river passing through the alluvial plain does as much scouring as it does depositing of material; only when its waters are led off into canals where the current is reduced to minimum or when they encounter an obstruction is the deposit marked, and then, so thick is the water, it is very heavy and very rapid. The primitive settlement of Ur stood on a knoll on the left or east bank of the Euphrates which a few miles further down turned somewhat to the east; the left bank was the point of danger, the tendency of the river being to shift its course eastwards – it now runs in a south-easterly direction eight or ten miles away from Ur: in a great flood then the town was so situated as to bear the brunt of the disaster. None of our pits are sunk through the middle of the old town site, all are to the north and east of it, and this explains the diverse phenomena which they present. The town was on a mound and already the rubbish thrown out from its walls formed a considerable talus against its eastern slope where the low ground seems to have run down to a water-course which, crossing diagonally the site of the later city, emptied into the river just below the town: it is into this rubbish talus that our pits Y and Z are dug, and Pit C touches the extreme end of it. The flood, coming from the north, overwhelmed the northern part of the town, which probably extended beyond where the Ziggurat is now, and met the obstruction of the citadel mound and its talus of rubbish; here then it would heap its silt, and this is precisely the spot in which we have found it lying most thickly. The houses at the mound's foot were, of course, buried, but as here the current lost its force in what became a backwater they were buried under the clean silt brought down from the upper reaches; the more violent stream, carrying with it the debris from the northern low-lying quarter, swept round the foot of the rubbish-heaps and as its strength abated dropped there a mixture of mud and refuse such as we find in Pits K, L and C. Had we dug in the middle of the town mound, as did the excavators at Warka, we should have found no trace of silt, nor should we have found any had we dug in the surrounding plain; it was by the accident of discovery that our pits were sunk in just those places which could produce the only possible material evidence of this historical inundation. I say "historical" because from the outset we were sure that the flood of which we had found so unexpectedly the traces was the Flood of Uta-napishtim (and incidentally therefore of Noah also) and it was as such that I published it,<sup>3</sup> two days later Professor Langdon announced that similar evidence of the Flood had been found in the previous year at Kish, but as the two

<sup>1</sup>In *L'Anthropologie*, XLI, 1931, p. 271.

<sup>2</sup>The report is quoted in full in Appendix VI, p. 164.

<sup>3</sup>In a letter to *The Times*, March 16th, 1929.

floods could not be the same it became doubtful which, if either, could lay claim to relation with the Sumerian Flood story.

Now the question is not one of merely sentimental interest.

If the Uta-napishtim legend was entirely isolated we might amuse ourselves by arguing that however much embroidered by invention it was likely to be based, in the end, on the tradition of a real Mesopotamian deluge; but whether that was the case or not would be of small historical importance. What does matter is that, apart from the legend, the Sumerian King-lists refer to "the Flood" as marking an epoch in their history. These lists are the only document extant that even pretends to throw any light upon the earliest periods; they were certainly, as an examination of the different texts shews, compiled from earlier sources, and they were compiled as a framework of a history the substance of which is lost; but that framework would be of great value if we could venture to build upon it. Unfortunately the initial part of the King-lists is so corrupt, the longevity of its kings so fantastic, that it is tempting to jettison the whole as mythological or meaningless, which indeed many scholars have preferred to do. The discovery of the historical character of the First Dynasty of Ur did carry back the authenticity of the King-lists a stage but could not affect the improbabilities of their beginnings; but if the Flood could be shewn correct, if, that is, we could prove that such a disaster did overwhelm Sumer at a time not inconsistent with the Sumerian historical scheme (assuming that to be disembarassed of its travesty of dates) then we should have gone far towards restoring credit to the King-lists and could begin to regard them as a possible help instead of an impossible enigma.

Does then either of the 'Floods' of which archaeology has discovered evidence support the literary witness?

The date of the Kish flood is relatively fixed; a stratum eighteen inches thick of mud indubitably water-laid lies immediately under a stratum containing tablets of the 3rd millennium B.C. and over the top of a stratum in which are graves of the type of those of the Royal Cemetery at Ur. Clearly this cannot be the same as the Ur flood, the deposit of which lies under the Royal Cemetery and antedates it by a considerable period. That it should be the Flood of the King-lists seems to be ruled out by the following arguments:—

- (1) The Gilgamesh cycle of which the Flood story is a part, could not have taken shape in the relatively short interval between the Kish flood and the time of Sargon of Akkad, when it was well established.
- (2) The Gilgamesh cycle seems to have been known to the seal-cutters of the Royal Cemetery period, *i. e.*, before the time of the Kish flood which *ex hypothesi* should have supplied its genesis.
- (3) Writing was a familiar art in the Royal Cemetery period; had the Flood occurred after that date it would surely have had its written record and would have been correctly placed by the annalists instead of at the remote date to which the King-lists refer it.
- (4) For the same reason, the annalists would not have so misunderstood their authorities as to assign fantastic longevity to post-Flood rulers.
- (5) If the Flood came immediately before the First Dynasty of Ur, as does the Kish flood, then there is no room for the immensely long dynasties of Kish and Erech—in fact, for any dynasties at all. The discovery of the Flood, instead of supporting the King-lists, obliges us to discredit them altogether. Conversely, if we reject their dynasties, why should we assume that their mention of the Flood has any historical basis?
- (6) According to the King-lists the Flood caused a violent break in the continuity of the land's history. The Kish flood had no such effect. The graves below its deposit are contemporary with the Ur Royal Cemetery, and that cemetery leads up insensibly to the definitely post-Flood First Dynasty of Ur.

Two other "flood strata" were found at Kish, both lying under the graves of Royal Cemetery type; they are only a few inches thick and of themselves might not have attracted much notice, but in view of the difficulty of correlating the results from Kish and from Ur it has been suggested both by Langdon and, independently, by Peake<sup>1</sup> that the lower of them might correspond with the deposit of silt at Ur and together with it represent the Uta-napishtim deluge. Here again there is a difficulty of date; the third "flood-stratum" at Kish lies over the top of the Jamdat Nasr stratum and so cannot possibly be identified with the Ur deposit which lies below that stratum and is separated from it by al 'Ubaid II and III as well as by the Uruk period which we know from the Warka buildings. There is no parallel, and to me it seems unreasonable to expect one. I have pointed out that it was by the merest chance that our pits at Ur happened to hit on the flood deposit at all; it would have been a yet rarer chance if the single pit dug at Kish had been on a spot where the conditions were identical and the results therefore the same; actually the Kish pit is in the middle of a very extensive town site. Probably most Mesopotamian sites would shew water action at some level or another; high up in Pit F we find an area where the water-laid deposit is obvious (Pl. 2, a; v.

<sup>1</sup>Harold Peake, *The Flood*.



p. 58) but it is not continuous; the Kish (upper) flood was certainly something much more serious and we have no counterpart to it at Ur, again perhaps owing to the accidents of discovery.

We may now turn to the Ur flood and see how far the assumption that it is the Flood of the King-lists accords with the implications of those documents.

The dimensions of the Ur flood in themselves constitute an argument in favour of the assumption. To heap up a mass of deposit nearly four metres deep the water must have been at least half as high again and more probably twice as high. Lower Mesopotamia between the beaches of the upper desert is absolutely flat and the rise of the country from the head of the Persian Gulf northwards is surprisingly gradual;<sup>1</sup> an inundation which at Ur attained a depth of some eight metres<sup>2</sup> would have laid under water practically the whole country from the old rock coast-line south of Hit to Kurnah and the shores of the Gulf and would have obliterated all but the artificially terraced cities. A disaster of this magnitude would certainly have caused a break in the continuity of history and might well have become the basis for legend.

The sequence of events as given by the King-lists is as follows:—

- (A) The (very long) period of the antediluvian kings, these being based on different capital cities.
- (B) The Flood. After it there seems to be an interregnum.
- (C) The First Dynasty of Kish.
- (D) The First Dynasty of Erech.
- (E) The First Dynasty of Ur.

The archaeological sequence derived from excavation is as follows:—

- (A) The al'Ubaid period. This, as the evidence of Warka and of Eridu shows, was a long period; Its culture was very wide-spread.
- (B) The Flood. At Ur we have after the flood a short-lived survival of the al'Ubaid culture in a degenerate form, although the disaster can fairly be said to mark the end of a period.
- (C) The Uruk Period.
- (D) The Jamdat Nasr Period
- (E) The Early Dynastic Period in which comes the First Dynasty of Ur.

Obviously there is here a general coincidence which is of interest and does favour the identification of the Ur flood with that of the King-lists. But the broad lines of the archaeological sequence are established beyond question and it is the King-lists that are on trial; we can accept them only in so far as they harmonise with the facts of archaeology.

The fact that the King-lists make the Erech Dynasty item (D) whereas the archaeological sequence makes the Uruk Period item (C) involves no discrepancy because the names of the archaeological periods are purely arbitrary, resulting from the accidents of discovery. The "Jamdat Nasr" period is better represented at Warka than on the small and nameless site where its remains were first discovered by Professor Langdon and christened by him; had Dr. Jordan at Warka happened to find it first it would have been called the Uruk (or Erech) period, and then when the plain red or grey pottery which we call "Uruk ware" was encountered in the lower levels it would have been given a different name. The verbal discrepancy therefore does not matter, but this is far from implying that there really were dynasties corresponding to the archaeological periods. Nothing has been found at Kish to suggest that it was the capital city soon after the al'Ubaid period; but the Kish excavations affected but a small part of a very large and scattered site and of the earliest periods practically nothing came to light. On the other hand the extraordinary wealth and architectural magnificence of Erech are fully consistent with its having been in its time the chief city of the land; the splendid buildings seem to have originated towards the close of the "Uruk" period and to have flourished in, if not throughout the "Jamdat Nasr" period, *i.e.*, the period which the King-lists would call "the First Dynasty of Erech." Pictographic seal-impressions from Ur belonging to the Jamdat Nasr period are read by Legrain<sup>3</sup> as giving a form of the later royal title, "King of the Four Quarters of the World" followed by the ideograms of different cities; this would imply a unification of the country under a single ruler and would thereby justify the use of the term "Dynasty." Perhaps a more valid objection to the apparent parallel between the archaeological and the traditional schemes is that under item (E) the first Dynasty of Ur and the Early Dynastic Period are not synonymous; that dynasty only came into existence late in the period and it would actually seem that in an earlier phase of the period Ur, so far from being the ruling city, had itself been subject to the King of Lagash.<sup>4</sup> It is however, possible that dur-

<sup>1</sup>Ur is today 160 miles from the Gulf and the railway station lying in the plain is only 4.30 metres above sea level; the plain has risen in the course of time and the ruins of the pre-Flood houses of Ur are only just above the sea level of today.

<sup>2</sup>The source used by the authors of the P version in Genesis gave fifteen cubits, *i.e.* eight metres, as the depth of the Noachic flood. As regards the statement that "the mountains" were covered, Sir William Willcocks (*From the Garden of Eden to the Crossing of the Jordan*, 2nd edition, p. 20) remarks that the same word "mountains" is used by the modern Iraqi for those slight rises of the ground which are out of reach of the water in the irrigation-channels and therefore remain uncultivated; to the casual observer they are hardly to be distinguished from the plain.

<sup>3</sup>*Ur Excavations*, Vol. III, *Archaic Seal-Impressions*, No. 397, p. 37.

<sup>4</sup>E. Burrows in *Ur Texts*, Vol. II, *Archaic Texts*, p. 17 (66).

ing the greater part of the period Sumer was divided into city states independent of any central government and that only late in the day did a line of kings – those of Ur – attain such general power as justified their inclusion amongst the Sumerian dynasties; merely local rulers, even important ones like Gudea in a later age, would have no place in the List.

It would be ludicrous to demand absolute agreement between archaeological periods which are at best vague summaries of partial evidence and a dynastic system ill supported or unsupported by contemporary literature. But the general coincidence which I have remarked is emphasised by the difficulties from which the Sumerian scribes obviously suffered. It has often been pointed out that the reigns of the antediluvian kings are reckoned in *sars* of 3,600 years (the square of the basic numeral 60) so that they would seem to be based on some mathematical or astronomical theory held by the editors. The kings of the First Dynasty of Kish are credited with reigns of anything up to 1500 years but there does not appear to be any system underlying the various figures. In the First Dynasty of Erech the first five kings enjoy supernatural reigns of from 100 to 1200 years, but the last seven reigns are normal and even short. In the First Dynasty of Ur we have four reigns of which only the first, that of Mes-anni-padda, is unduly long (80 years) and we now know that this is due to conflation, A-anni-padda being omitted and his regnal years attributed to his father.<sup>1</sup> It will be seen that there is here a regular progress from pure theory through error to accuracy.

Now for the First Dynasty of Ur there were available written records, imperfect, presumably, thanks to the lapse of time, but intelligible; the texts of that period that we possess present no difficulty to the epigraphist. The art of writing was introduced into Mesopotamia apparently towards the close of the Uruk Period, when the script was pictographic, and was developed during the Jamdat Nasr Period, the linear script being very gradually transformed into the cuneiform. I would suggest that the Sumerian scribes of the early part of the second millennium B.C. could perfectly well cope with an original text of the Early Dynastic Period, would be hard put to it to make sense of a late Jamdat Nasr text and if faced with an early Jamdat Nasr or an Uruk text would have been completely at sea. This suggested explanation assumes the existence of King-lists written as early as in the Jamdat Nasr period, but the assumption is not at all unreasonable.

The presence of divine names in the early dynasties is not a valid argument against the historic character of lists. It can be argued that some kings had theophoric names and the later scribes, dealing with old documents, recognised the ideograms for the gods but could not read the other signs composing the name and so recorded only what they could understand. But it is just as likely that these gods were really deified kings. Dumuzu, Lugalbanda and Gilgamesh are amongst the first five kings (impossibly long-lived) of the First Dynasty of Erech. Burrows<sup>2</sup> remarks that "in rather surprising agreement with the tradition which assigned Gilgamesh and Dumuzi to the first dynasty of Uruk, neither of these names occurs in the archaic tablets" found at Ur which he dates between the Jamdat Nasr and the Fara tablets, *i.e.* to the first phase of the Early Dynastic Period; both however form part of theophoric names one on a tablet more or less contemporary with the Royal Cemetery, one on a cylinder seal from that cemetery,<sup>3</sup> and Gilgamesh commonly figures on seals belonging to the latter part of the Early Dynastic Period. This is entirely consistent with the deification late in the Jamdat Nasr Period (*i.e.* towards the close of the First Dynasty of Erech) of kings who had reigned in the early part of it; their cult was unknown at Ur in the time of the archaic tablets but by the time of the Royal Cemetery had become popular.

It is never wise to reject traditions off-hand; in most cases they contain a modicum of truth,<sup>4</sup> even if it be only as a background for fiction. A mere catalogue of names and figures has no artistic justification and for that reason is the more likely to represent a groping after historic fact. The King-lists seem to me to get a measure of support from archaeological discoveries, but that support does depend on the identification of the Ur flood with that of the King-lists.

It is perhaps not out of place to enquire how the Flood could come about. Mesopotamia is of course a land of floods, and it has been argued that therefore there is no need to look for any outstanding disaster as the origin of the Flood story – it would have grown up naturally from what men saw happen year by year. But that argument is psychologically false. It is not the normal that spurs the imagination but the abnormal: the annual rising of the Nile to which Egypt owes prosperity has given occasion to no tale of a deluge, but the monstrous transformation of that beneficent inundation into a weapon of wholesale destruction would become a bogey to terrify many generations of men. But none the less, to explain the huge banks of silt thrown up against Ur mound no unfamiliar agency need be invoked, only the unusual combination of factors usual in themselves but seldom coincident. We know from the analysis of the silt that

<sup>1</sup>This scribal error, due to the similarity of the names, is an example of the "haplography" familiar in the case of copyists of manuscripts.

<sup>2</sup>*Op. cit.* p. 21, para. (6).

<sup>3</sup>Burrows, *op. cit.* Supp. 18, 25, and *Royal Cemetery*, p. 316, U.11418.

<sup>4</sup>The tradition that Eridu was the oldest of Sumerian cities is in harmony with the archaeological evidence so far obtained.

it comes from the upper reaches of the Euphrates; it is therefore to the rise of the river that we must look as the main cause of the flood. The legend speaks also of constant and heavy rains, of storms and the "breaking up of the fountains of the great deep." A strong wind from the south will bank up the waters at the head of the Persian Gulf to a height of three feet and to that extent hinder the discharge of the river waters: rain in the valley will not cause a flood, but it will contribute to it, and heavy rains in the Persian hills will breach the banks of the Tigris and swamp much of the country; if the Euphrates were to rise concurrently with the Tigris (as happened on a relatively small scale in 1929) then a real flood results. If there had been a succession of cold winters and bad summers resulting in the accumulation of vast masses of snow in the Armenian and Taurus mountains, as presumably took place in such a minor glacial phase as the Gschnitz,<sup>1</sup> followed by a retreat of the ice cap and the rapid melting of the snows, with the probable accompaniment of heavy rain, then in place of the normal rising of the rivers in Mesopotamia we should have calamity: with the south wind bringing the rain (the south and south-east winds are the ordinary rain-winds today) and holding up the outflow of the rivers, the calamity would acquire proportions fully in accord with the evidence of the Ur excavations and a flood eight metres deep may well have spread over what was for the farmers of the Mesopotamian valley the whole world.<sup>2</sup>

### Part III: Al 'Ubaid II and III

In Pit F we found some 49 graves<sup>3</sup> dug down to and into the Flood deposit, all containing pottery of the al 'Ubaid type; they therefore belonged to the al 'Ubaid period but were later in date than the Flood.<sup>4</sup> An examination of the graves shews that they fall into two quite distinct categories.

In the first place there is the question of depth. Naturally graves are not necessarily dug to any specified depth, and one must expect to find contemporary burials at different levels, as indeed is the case here where the differences between graves presumably almost contemporary and certainly not very far removed from one another in time are considerable: but as a whole the graves fall into two groups separated by a clear interval. Thirteen graves lie between 4.60 m. and 6.30 m. above sea level, all the rest between 1.00 m. and 4.00 m. above sea level and only five of them above the 3.50 m. line; between 4.00 m. and 4.60 m. there are no graves at all. The upper group lie in many cases directly above graves of the lower group and must therefore be somewhat later in date but not necessarily a great deal later: on the other hand while making all allowances for the vagaries of the grave-diggers it is very difficult to suppose that starting at the same ground level they would make one grave-shaft five metres deeper than another; everything suggests that there was a time interval between the two groups during which the ground level had risen. Unfortunately the upper part of the Flood silt had been so disturbed by the later graves that the shafts of the earlier could not be traced to their top. In the south-west part of our pit, where there were no graves, the silt did seem to be interrupted at the 4.50 m. line by a temporary surface (*v. p.* 68) from which the lower series of graves might have been dug; the fact that the highest graves of the upper series lay actually in the pottery stratum above the Flood deposit means that they at least had been dug after a certain depth of pottery debris had accumulated, which was assuredly not the case with the lower graves because (a) their depth would then have been quite unreasonably great and (b) had their shafts been cut down through the solid mass of pottery deep into the Flood stratum and then filled in again with the excavated material some at least of the pottery would have been found deep in the shafts; this was never the case, and the cleanness of the filling (which made it virtually impossible to trace the shafts) is proof that the lower interments were made before the pottery layer had begun to form above the silt. It still remains doubtful whether they were dug from the present surface of the silt or from a temporary lower surface, and it is impossible to fix the level in the pottery layer from which the grave-shafts of the upper series were cut: none the less the difference in date between the two groups of graves is clear from the stratigraphical evidence and will be made more striking by a comparison of their contents.

<sup>1</sup>My reference here is to Peake, *op. cit.* p. 114. The Gschnitz phase is usually dated to about 4,500 B.C.

<sup>2</sup>Comparisons with modern times are not always fair, owing to the change in local conditions; thus, while the level of the Ur plain has risen by about four metres the Euphrates in its old course was also at a much lower level in relation to it and was presumably not yet retained by banks so high: but it is worth mentioning that the railway station at Ur is more than two metres below the bottom of the bed of the river running ten miles away and in the case of a break-down of the banks in flood-time would be completely under water.

<sup>3</sup>Some of the graves were disturbed and the confused remains of more than one burial have been recorded together.

<sup>4</sup>At this point it is well to enter an objection to the nomenclature adopted by Professor Gordon Childe (in *The Most Ancient East*) according to which by an unfortunate combination of the silt strata at Ur and at Kish the whole of al 'Ubaid becomes "the First Prediluvian culture" and a "Second Prediluvian culture" covers the periods of Uruk and Jamdat Nasr, the great cemetery at Kish and apparently a part of the Royal Cemetery at Ur as well as Susa II. "The Flood" was a single event in time and nothing coming after it can be called Prediluvian: the only thing that comes before it, so far as we know, is the culture of al 'Ubaid I.

## The Graves of al 'Ubaid II

The Flood deposit with its thickness of some four metres is a material factor which cannot be disregarded and the precedent set by the Sumerian annalists would further justify us in taking the Flood to mark the end of an epoch, but it must be admitted that the difference between the remains in the pre-Flood house ruins and those in the post-Flood graves is one of degree only and not of kind. But for the conditions of discovery we might have accepted the graves without question as being those of the inhabitants of the houses: the same type of pottery is found in them, the same terra-cotta figurines; in the case of an isolated grave found in Pit Z it is only its relative position that seems to assign it to al 'Ubaid I rather than to al 'Ubaid II, and its contents would fit in quite well with the series of objects from the lower group in Pit F. But the barrier of the Flood cannot be overlooked, and the lower graves – which after all are necessarily later than the houses – must be assigned to a sub-period which we call al 'Ubaid II; as to the propriety of distinguishing these from the upper group and calling the latter al 'Ubaid III there can be no question.

The lack of distinction between sub-periods I and II is of course only natural. The Flood did not kill off the entire population and its survivors had not undergone any spiritual or cultural revolution; after the disaster they continued to live the life of their forebears. That they were impoverished we cannot doubt; that their culture was so weakened that it soon collapsed we shall see reason to believe; but for the moment they were the same people practising the same arts and customs; what we find in their graves will serve equally well to illustrate the pre-Flood ritual.

The graves were rectangular shafts cut in the firm soil. In some cases the bottom of the shaft was covered with a sort of rough mosaic of broken potsherds (Pls. 5,d; 6,b) laid flat on the earth with the painted side, if there was any painting, uppermost; sometimes a number of fragments – they were always fragments of large vessels – belonging to a single vessel would be found in the "pavement," but never enough to form a complete pot, so that it would appear not that vessels of offering were ceremoniously broken and their pieces placed in the grave but that odd fragments of broken vessels were collected which might be broken again into pieces of more convenient size which would lie flatter and fit better together.<sup>1</sup> On the pavement, or on the bare earth where no pavement had been laid, the body was placed on its back, fully extended with the legs straight and the arms by the sides, the elbows slightly bent so that the hands were folded above the pelvis: it was an attitude peculiar to the al 'Ubaid people, never to be found in the graves of any subsequent inhabitants of Sumer. No attention was paid to the orientation of the body; in different cases the head lay to the NE, the SW, SE or S (in many, the bones were too much decayed for the position to be made out) and there was therefore no religious motive governing the direction in this any more than there was in later periods; only the attitude was constant. Whether or not the body had been wrapped in matting, as was usual in later times, or in cloth, could not be told – there was no trace of anything of the sort, but in view of the age of the graves and the nature of the soil no traces could be expected and the negative evidence is not decisive: a polished bone pin in Grave PP (U.15520, Pl. 15) might be taken as evidence of the dead having been buried in their clothes. Round the right wrist of one of the bodies in Grave T was a string of small shell and steatite ring beads, but otherwise there was no evidence of personal adornment unless we can accept as such a peculiar phenomenon observed in two graves, JJ and KK; in them the upper part of the body was covered with a fine red powder, and in JJ there lay by the head a lump of red haematite paint; whether the bodies had been painted it was impossible to say, but the powder was clearly the same as the paint in the lump and the fact that the figurine U.15379 (Pl. 20) from Grave T had its face painted a bright red may point to a custom of which the "red graves" give concrete illustrations. In Grave EE there were two clay net-sinkers, presumably the instruments and symbols of the dead man's craft, but in no grave were there weapons of any sort. The only other objects apart from the vessels of offering were the clay figurines found in Graves O, Q, T (two examples), AA *bis*, JJ and QQ (*v.* Pls. 20-22); these generally lay near the head or by the waist but in two cases seem to have been held in the hands.<sup>2</sup>

The vessels for food and drink were all of pottery and most of them were painted; they were placed as a rule at the foot end of the grave (Pl. 5,c,e,f) but not invariably so (Pl. 6,a, PFG/P), and the arrangement would appear to have been one of convenience rather than of ritual. Their presence in the graves shews at least that the al 'Ubaid people recognised that the soul after death has need of provision of some sort; whether this was for a journey to or a life in another world or whether it was to satisfy the soul with its existence in the grave and so prevent a malignant haunting of the living (which precaution also implies that the soul continues to exist) there is no means of telling; a proof of a certain degree of religious belief at any rate is secured. The pottery in its general type resembles that found in the pre-Flood strata: but if the vessels from the graves be compared with the sherds

<sup>1</sup>Precisely similar pavements made of a mosaic of broken pot-sherds, many of them painted, have been found in chalcolithic houses at Tal esh Sheikh near Atchana, Hatay.

<sup>2</sup>The figures have been discussed above, pp. 12 ff.

from below the Flood level at Ur and with those collected from al 'Ubaid and Eridu (*v.* Pls. 46-50) a difference of quality does make itself felt. The very thin and hard wares whose entire surface is covered with minute patterns is not represented in the graves but is common on the earlier sites; in general the all-over decoration of many early specimens seems in the grave pottery to be simplified and reduced so that ornament only emphasises the salient parts of the vessel; the bold and sweeping treatment of conventionalised plant motives seen, e.g., on Pl. 47, Nos. 5-11, finds no parallel in al 'Ubaid II. Compared with the preceding age that of the survivors of the Flood shews a certain poverty of style and perfunctory repetition of such decorative schemes as involved least trouble or imagination: The decadence has not gone far, and did we not know that the pottery was in point of fact later we might have explained otherwise the disparity that does exist, but it is a real disparity and whether decadence had already begun before the Flood came or was the direct result of the Flood (as seems more likely) we must define the sub-period al 'Ubaid II as that in which the culture had passed its zenith and the admirable art of the al 'Ubaid I potter was on the downward grade.

#### The Graves of al 'Ubaid III.

In the confused graves of al 'Ubaid III, lying high up in or above the top of the Flood deposit the painted pottery is reduced to a minimum—in no grave was more than a single example found. Decoration is confined to one type of vessel, the hemispherical drinking-cup of Type aU. 23 or its variant aU. 25 and, in one case, the footless type aU. 19, and is then limited to perfectly plain horizontal bands of black paint; on the other hand in the plain pottery types such as aU. 9 which were unknown in the older graves make their appearance and are not uncommon; in one of the graves there was a vase the upper part of which was covered with a haematite wash, again a complete innovation and one that anticipates the fashions of a succeeding period. Two graves contained limestone bowls, one a stone mace-head, one a stone axe (U.14990, Pl. 14) and one the remarkable spear-head of pure copper<sup>1</sup> (U.14992) on Pl. 30. But the great difference between these and the earlier graves was in the bodies themselves. One of them lay rigidly extended after the old fashion, but in every other case where the condition of the bones made observation possible the body, wrapped in matting, lay on its side with the legs slightly flexed and the hands before the face in the attitude which, except during the Jamdat Nasr period, was to prevail throughout all later Sumerian history.

The change could scarcely be more marked. People are as a rule conservative where burial customs are concerned, and here we have a new attitude adopted for the body, the clay figurines no longer appear<sup>2</sup> but instead there are weapons, the very class of object that was conspicuous by its absence from the older graves; and where the type of offering is the same, as in the vessels for food and drink, there has been a radical change in their character and even in their material. Just as the difference in the levels of the two groups of graves seemed to demand a lapse of time for the accretion of soil, so the differences between the graves themselves mean that the groups do not form continuous links in the historical chain but are separated from each other by a time gap sufficient to allow of the development of art and of belief which they shew.

Why this particular piece of ground was abandoned as a place of burial and after a time re-used for the same purpose cannot be known but why during that time the changes observed in the graves had taken place can perhaps be explained. At Ur we have unfortunately no good stratification to throw light on the history of the period, no succession of superimposed houses such as are found in the deep shaft at Warka, only for the next five and a half metres in our Pit F the formless debris of the potters' factory. It is obvious that in dealing with this mass of sherds strict stratification is impossible—probably at no time was the surface level, rather it must have been a succession of heaps the hollows between which were filled up by later dumping, so that an analysis by horizontal layers if interpreted too strictly would be positively misleading; further, the lower layers at least were disturbed by the grave-diggers of al 'Ubaid III, who naturally upset any stratification there may have been and the digging for the foundations of the kilns and such leveling as was required for their use would have confused matters yet more; broad generalisations are all that can be risked. But if we take the proportionate analysis of pottery types given in Appendix I (pp. 67-68) we shall see that al 'Ubaid pottery was fairly common from the top of the silt stratum (level 5.50 m. to 6.50 m.) where it formed the vast bulk of the decorated wares (729 examples against 4 of burnished red) and continued up to about level 9.00 m. (the dozen examples found in the next half-metre and scattered pieces at higher levels should be dismissed as fortuitous). There is from the outset an intrusion of other

<sup>1</sup>For the analysis, *v. Ur Excavations* Vol. II, p. 291.

<sup>2</sup>Though as the number of the graves is small it would perhaps be rash to lay too much stress on their absence.

types; in particular the plain haematitic red ware increases rapidly in proportion and between 7.50 m. and 8.00 m. is actually more common than that of al 'Ubaid,<sup>1</sup> and this is just the ware of which an example was found in an al 'Ubaid III grave. Between levels 8.50 m. and 9.00 m. was one fragment of a ware extremely rare at Ur, but of which there come complete examples from the Jamdat Nasr cemetery to be described in Chapter III, a finely-burnished grey-black pottery made in a smother-kiln; and from level 6.50 m. to the top of the pottery debris there were masses of "flower-pots" of Type JN.2, very roughly made with thick and clumsy walls but characterised by the rim which is angular, flat-topped and oblique, sharply trimmed with a knife after potting.

Now at Warka in the deep shaft which has given such excellent stratification<sup>2</sup> the older al 'Ubaid ware is common in levels XVIII, XVII and XVI; in levels XV and XIV it is rare and it disappears altogether in level XIII. The later al 'Ubaid ware begins in level XII and continues through level XI into level X. In levels XVIII, XVII and XVI there were found a few isolated examples of plain red and grey wares which the excavators dismiss as being due to accident; in level XV the red is still rare, the grey represented by a single sherd; but in levels XIV and XIII this so-called Uruk ware becomes relatively common, especially the red variety; it persists through the next levels side by side with the later al 'Ubaid pottery and after the disappearance of the latter becomes, and up to the end of level VI continues to be, the characteristic fine pottery of the site.

At Warka therefore there is a time gap separating the two al 'Ubaid cultures recognised by the excavators and it is marked by the intrusion of precisely the type of pottery which we find at Ur associated with our period al 'Ubaid II almost from the outset and ultimately replacing al 'Ubaid III just as at Warka it supplants the latest al 'Ubaid ware. The Uruk ware is certainly foreign to Mesopotamia and of northern origin—the grey variety offers strong analogies with the "Minyan" pottery found as far away as Hissarlik in NE Asia Minor—and its appearance must mark an invasion of the river valley and its occupation by the conquerors. Such incursions are a commonplace in Mesopotamian history, but whereas they brought in new blood and new customs it would be absurd to suppose that they involved the disappearance of the old stock; the newcomers would be a minority, though a predominant one, and the persistence or the recrudescence of the older culture would always be possible. This would explain the real differences which do exist between the phenomena at Ur and those at Warka. Against the complete disappearance of al 'Ubaid wares in the Warka layer XIII Ur gives a mixture of the two wares in the lower strata of the pottery belt; the al 'Ubaid ware which re-appears at Warka in layer XII is not the same as that in the later Ur graves but belongs to our subperiod al 'Ubaid II, so that the gaps are not synchronous; our decadent sub-period al 'Ubaid III does not seem to be represented at Warka at all.

We can safely assume that the whole lower valley had been weakened and its population seriously reduced by the flood which has left its silt over the houses of Ur. A northern race seizes the opportunity to invade the land; necessarily they occupy Warka before they arrive at Ur, and at Warka the centre of the town which like a citadel dominated the rest was taken over by them to the exclusion of the subject natives; that as conquerors they would be bound to do, and if they brought with them their own arts and made their own pottery then, excavating as the Germans have done in the middle of the city we might expect to find, as they did, the buildings of a generation or two witnessing solely to the new culture and shewing no vestige of the old: after a time restrictions would be relaxed, the old and new cultures would mix, and the coincidence of al 'Ubaid and Uruk pottery in layer XI implies not the re-introduction of a forgotten industry but the accommodation of two previously exclusive societies. But the new element is definitely the stronger, and the persistence of the old is relatively short-lived and ends not so much with a slow decadence as with the abandonment of the effort to survive; it stops while still in the al 'Ubaid II stage. At Ur the invasion must have come somewhat later, supposing that the invaders consolidated their line of advance; certainly our earliest graves, dug before any of the pottery debris with its admixture of types formed above the cemetery, belong to the undiluted culture inherited from the pre-Flood people. Presumably the same occupation of points of vantage took place, and the excavation of them might shew the same exclusive memorials of the invading stock as appear at Warka, but our pits have not touched those points; the pottery layer shews a population predominantly of the old type but coming more and more under the cultural influence of the new. After a gap, the few graves of the al 'Ubaid III series shew the old culture at its last gasp. Here, perhaps because the ruling class was proportionately smaller than at Warka, the agony had been long-drawn. Normally the foreign pottery held the field as *objets de luxe*, but potters of the old school persisted in turning out, at least for funerary purposes, poor mechanical ghosts of the splendid painted vessels used by their ancestors: even the burial customs had changed, and though a few obstinate traditionalists might be buried in the rigid posture of the past yet most had adopted the fashion of their conquerors and were laid to rest as men asleep, taking with them their weapons but recking nothing of the sacred figurines that had accompanied their forebears.

<sup>1</sup>A further warning is required namely that fragments reckoned separately may have come from the same vase; all figures therefore must be accepted with reservations.

<sup>2</sup>A. von Haller, in *Abhandlungen der Preussischen Akademie der Wissenschaften*, Phil.-Hist. Klasse, 1932, No. 6, p. 31.

## CHAPTER III

## URUK AND JAMDAT NASR PERIODS

The period between the collapse of the al 'Ubaid culture and the introduction in Sumerian building of the round-topped "plano-convex" brick to replace the flat brick hitherto employed has been divided into the two phases called after Uruk (= Erech = Warka) and Jamdat Nasr respectively. As is usually the case in archaeological research when dealing with a new field, the pottery of the two periods was the basis for their separate recognition; at Warka there had been found in the strata succeeding al 'Ubaid a plain red haematite-coloured ware, wheel-made, generally burnished but sometimes matt, and with it, but more rarely, a black or grey-black finely burnished smother-kiln ware, also wheel-made; there were the luxury-wares of a period in which for other purposes hand-made vessels were freely employed: at Jamdat Nasr had been found the brilliant three-colour painted pottery named after that site. The distinction between the periods holds good in the light of further knowledge, but a definition of them in the terms of these wares alone is no longer satisfactory; we have to reckon with other fabrics also, and in the case of Uruk and Jamdat Nasr we shall see that the wares are not mutually exclusive but overlap, being in use at the same time and in the same place. Since the pottery is our main guide through a difficult period it would be as well to begin with a description of the varieties found.

- (A) The Uruk ware presents a good deal of variety. Of the red ware there are two types, as mentioned above, which differ in the colour of the red, one being burnished and of a fine sealing-wax tint the other unburnished and plum-red. In a few instances of the burnished ware the process of polishing has removed some of the applied slip or paint and partly exposed the under layer; an elaborate example of this is the vase U.19981 on Pl. 25. The black ware most characteristic of the period has a slip or engobage over a brownish-grey body clay and is finely burnished; the colour is due to smother-kiln firing; the pottery has a rather fatty rich appearance. But there is also, and not uncommonly, a grey or slaty-grey ware, smoothed but not properly speaking burnished, which is produced by the same process but generally has no slip; the good examples are of very fine clay, but there are rougher specimens, sometimes with ribbed or twisted handles. Examples of the finer class are shewn on Pl. 25.<sup>1</sup>
- (B) Examples of the Jamdat Nasr ware are given on Pl. 26. It is rarely that this pottery is well preserved; the paint is put on over a slip, the slip itself is inclined to flake away from the body clay and the paint becomes loose and powdery; consequently in most examples the design has suffered seriously and only too often the removal of the dirt encrusting the vase may involve further destruction; the skill of the ornament is indeed curiously at variance with the technical quality of the pottery, for while the forms are good the potting is none too skilful, the walls being often clumsily thick, and the firing is usually light and uneven.<sup>2</sup> where however the surface is in good condition the effect of the polychrome painting is extraordinarily rich.
- (C) Distinct from this though also found at Jamdat Nasr is a ware in which no slip is used but a red paint is sparingly applied direct to the surface of the body clay, usually a rather coarse buff or greenish-buff ware, though examples in red clay do occur (Pl. 26,c); it seems to be confined to pots of the larger sizes.
- (D) What I have called the "red paint on light" ware is again different for the vessels are generally small, the clay fine, the surface is either a light pinkish cream slip or is the body clay of the same colour brought by water-smoothing to a fine engobage very similar in effect to a true slip, and on this the decoration is in red paint and is nearly always confined to plain horizontal bands, though occasionally there are examples of hatching.
- (E) "Reserved slip ware;" in this case the finished vessel was covered with a slip of finer clay of a lighter colour which was then partly wiped off in parallel streaks so as to make a simple pattern of alternate bands in which the lighter and finer slip stands out in very slight relief and contrasts with the colour and texture of the exposed body clay. It is a delicate but effective method of decoration.

The unpainted pottery also shews certain features which are peculiar to distinct periods and therefore should be useful criteria for dating purposes. Rough hand-made wares are sometimes decorated with

<sup>1</sup>A detailed account of the ware and of the conditions of its discovery at Warka is given by A. von Haller, *loc. cit.*

<sup>2</sup>This is not merely a local peculiarity; cf. Mackay's *Report on Excavations at Jamdat Nasr* (*Field Museum of Natural History, Anthropology, Memoirs*. Vol. I, No. 3).

combed, slashed or scabbled ornament; spouted types are common; the simple loop handles found on the al 'Ubaid pottery are replaced by rings or tall vertical handles applied to the side of the pot which are either ribbed (made of two or three bars of clay set side by side) or twisted rope-fashion. It is difficult to explain why so useful a thing as a handle having once been invented should have dropped out of use; but the fact remains that whereas handles are relatively common in the early periods only one of the two hundred and fifty clay types recorded from the Royal Cemetery and the Sargonid cemetery boasts a handle, and after that handles disappear altogether, to be re-introduced only in the Neo-Babylonian and Persian periods.<sup>1</sup>

The material found at Ur to illustrate the periods under discussion comes from some 340 graves, from the pottery deposit and later building remains in Pit F, from deep excavations close to the Ziggurat, and from the outlying site of Mereijib, ten miles south of Ur. Since the historical framework into which the objects must be fitted depends ultimately in large measure on the pottery sequence, I propose to begin by dealing with that only, taking first the pottery from the graves and then that from Pit F.

Of the graves to be discussed here<sup>2</sup> some, Nos. 348 to 367 were in Pit Y, excavated in 1929-30, Nos. 1 to 137 were in Pit W, excavated in 1932-3, and the remainder, Nos. 141 to 347, were in Pit X, excavated in 1933-4; those in Pits W and X were practically contiguous, those in Pit Y only a few metres away. The former gave between them the whole width of the ancient cemetery since at the NW end of Pit W and at the SE end of Pit X respectively the graves were few and scattered whereas where the two pits tended to meet they lay very close together in the soil and one above the other to a depth of three metres; Pit Y seemed to be more in the middle of it, the graves extending into the unexcavated area to the southwest; in this pit they lay so thickly that it was always difficult and sometimes impossible to differentiate one from another.

From the contents of the graves, and especially from the types of pottery, it was from the outset clear that we had to deal with a number of disparate burials between them representing a considerable lapse of time: Jamdat Nasr three-colour painted vases, vases of plain red ware, of burnished black and grey ware, of "reserved slip" ware and in some cases of forms identical with those from the Royal Cemetery all occurred, and according to such knowledge as we possessed these could not all be contemporary; further, in Pit X especially, there was a strong contrast between the upper and the lower graves in respect of the stone vases; in the lower graves these were rare and the forms were simple, for the most part open bowls; in graves higher up in the stratum the stone vases became astonishingly common, sometimes even to the exclusion of pottery, and the forms and materials were notable varied, diorite and basic diorite, limestone, calcite, gypsum, alabaster and steatite all being found.

With such a variety of contents the graves might have been expected to arrange themselves easily into a historical sequence; but they lay so thickly in the ground and were compressed into so small a vertical space, one being constantly cut through another, in which case positive measurements of depth were definitely misleading, that stratification could not give any detailed results; the pottery seemed to afford the only criterion of value.

Since the results of the pottery analysis are of historical importance the method adopted may be briefly described. The first point was to establish which were the earliest and the latest types of vessel — the extremes of the sequence of development — and subsequently to fill in the intermediate steps: this could only be done by contrasting the contents of the latest and the earliest graves. In the case of Pit X it was obvious that the highest graves in the stratum must be later in date than the lowest at least in the middle of the cemetery area where the graves were superimposed several deep; it was not necessarily true of the NW end of the pit where the cemetery tailed off, graves were relatively few and, on the assumption that the cemetery had gradually grown outwards from its centre (a probability which had to be taken into consideration) might all be the last additions to the graveyard. Similarly as regards Pit W, this being again on the outskirts of the cemetery none of the graves were necessarily very late, while for that very reason the topmost were likely to be of the latest date of all. In the case of Pit Y everything was so mixed that I hesitated to take anything as evidence. Therefore only 26 graves were selected as definitely early by position, all these being from the SE end of Pit X; the top graves of both pits W and X were taken as necessarily late, 35 in all. They contained between them clay pots of fifty-eight types; comparison shewed that of these 14 were common to the two groups of graves, 26 occurred only in the late graves and 18 in the early only. Whatever later evidence might shew, the fourteen types were fixed as common to the whole cemetery period; the other types were to be regarded as "early" and "late" only provisionally, but a change could only be from either to the "common" group, i.e., a "late" type could not by any means become an "early" and therefore a certain amount of finality had been attained.

<sup>1</sup>Some of the Uruk-Jamdat Nasr pottery types find a close parallel in those found on the acropolis at Susa above the stratum Susa I *bis* and below Susa II; we have the same triple reeded handle, the flat plain ribbon handle, the twisted rope handle and the down-turned spout which marks the JN types 137, 142, 149, 152, etc. These are of northern derivation and illustrate the foreign influence which was operating upon Mesopotamia and Elam alike, *v. de Mecquenem, Mission Archeologique de Perse*, XX, p. 103, Fig. 2, and *cf.* Figs. 11, 21 and 22 in this volume.

<sup>2</sup>For the detailed account of them see Appendix III.



A list was then made of the pottery types and against each was set a record of all the other types with which it was associated in the graves; where to these associated types a provisional date had been assigned by our preliminary analysis it was duly recorded against it. As that analysis dealt with only 58 out of the 112 types found in graves, only in five cases were all the types associated with our supposed "early" and "late" types marked and found to be consistent — i.e., so far as available evidence went the results given by the simple comparison of upper and lower graves was confirmed. Seven types which by that comparison were given as "early" or "late" were now found to be associated with types of the opposite character and had therefore to be relegated to the class of "common" types persisting throughout the cemetery period; when that change was entered on the list no further contradictions remained.

We now had 21 "common" types, 14 "early" types and 23 "late" types given as such by the position of the graves in which they were found and confirmed by the consistent character of the types associated with them in so far as that was guaranteed by the same arguments. Since these were the only types for which the double argument of position *plus* association could be used they had to serve as the basis for any further analysis; there could not be evidence forthcoming to upset their attribution; all other types had to be judged merely by association with these, and must therefore be either of the same date as the classified types together with which they were found or, if they were found with both "early" and "late" types, be regarded as common.

Accordingly all the hitherto unknown types associated with the now fixed late types were duly marked as "late" wherever they occurred in the list. Only in a single case did such an entry clash with the date already assigned; Type 60 was found to be associated with both late and early types and was therefore re-marked as "common" wherever it occurred; otherwise there was no contradiction, and 25 new "late" types were secured all of whose associations were consistent. In the same way one "early" type was added. At this stage the list shewed that the types marked as "late" and "early," whether by the original double argument of position-*plus*-association or by association only, never occurred together; the "common" types associated with both the early and the late forms were limited to 22 of which 14 depended on the double argument and only eight had been added.

There remained the types which were not found in association with the types whose date was fixed by the double argument; they depended on their association with those fixed by the second stage in the process, and in eight cases all the associated types had now been dated; taking that evidence as final we secured four late and one early type and three were put down as common, one because it was found with both early and late forms, two because they were found only with "common" forms and there was therefore no evidence for assigning them to either of the exclusive classes. The entering of these dates involved no contradiction either in the lists already drawn up or in the case of the types still outstanding.

There remained nineteen types, of which six were isolated in their respective graves, so could not be judged by association, and the rest were associated only with each other and with a few types known to be "common": most of them came from Pit Y. Three which came from Pit X could now with reasonable certainty be dated by the association of the graves in which they were found with other graves whose pottery had dated them; eleven from Pit Y were left over for examination from another point of view.

At every stage in the work of analysis the lack of contradiction had been remarkable, and the result, whereby we were able to fix the relative date of 101 types out of 112, was within the limits of the evidence irrefutable. The graves were then dated by the pottery which they contained, being labelled, "early," "late" and "indeterminate," the last of course being where they contained no pots at all or only those of types common to the whole cemetery.

It at once appeared that the graves in Pit W were, as I had suspected, all late, contemporary with the upper graves of Pit X; of those which contained pottery 98 produced late types, 15 common types only, and not a single early type was found in them. Pit X had been excavated in two sections of which the NW section was finished before the other was begun; in each case the graves uppermost in the soil yielded only late and common types, then came a belt where the clay pots (for the most part few in number) were all of common types, and at the bottom only common and early types were found except in half a dozen graves at the SE edge of the cemetery where *ex hypothesi* late graves were to be expected at a low level. The evidence of the pottery and of the position of the graves was on the whole so consistent that it was now possible in many cases to date by their position in relation to other graves the graves which contained no datable pot types; the indeterminate graves of the upper and lower strata could thus be reduced in number to a minimum, and there remained in the middle stratum a large number of graves whose position and the common character of their contents alike shewed that they belonged to an intermediate position in time; we had thus in the cemetery three recognisable time divisions.

There remained the stone vases. In spite of their great number they were not likely to be of so much use as the clay pots for obvious technical reasons. A potter working on a wheel acquires very great manual precision so that his output within the limits of each type of vessel demanded of him by fashion tends to uniformity: a skilful potter today can throw thousands of cups of one pattern and they will be identical to a millimetre. The ancient potter did not in point of fact work to this standard, but he was

reasonably consistent; his wares can be classified in types to which with only minor variations he adheres, the introduction of a new type or the dropping of an old is a noticeable fact and can only be explained by a change in the demand, i.e., by some social need which implies, or the satisfaction of which implies, a new departure in time. Pottery is so valuable a help to chronology because it combines recognisable uniformity throughout a period of use with adaptability to changing circumstances. But the maker of stone vases was in quite another case. Fashion might demand of him certain forms, but he could only approximately satisfy the demand. In the first place he did not deal, as did the potter, with a raw material which he could himself make uniform and of the precise consistency most suitable to work; his materials were different and of every degree of hardness, so that different methods had to be employed to achieve similar ends. A vessel of alabaster or of soft limestone could be carved with a knife, and we possess examples on which the tool-marks are left and shew that a knife was indeed used; a steatite bowl might be gouged out with a chisel—we have an unfinished specimen; but for diorite the cutting-tools of the time were inadequate, and we find constantly the stone drill-points (used with a bow drill) (*v.* Fig. 5, p. 14) whereby the more stubborn stones were hollowed into vessels. But apart from the technique the material presented another difficulty; stone was rare and the vase-maker had to use what he had as economically as possible; the size and shape of the lump of stone at his disposal would go far to determine the proportions of the finished vessel. Consequently there is little uniformity in his output, types tend to merge one into another and on the whole the survival of a type is determined more by the ease with which it can be manufactured than by any other consideration; certain highly individualised types may be introduced and soon die out, thereby characterising a period, but the more generic forms such as the open bowl will vary enormously in the products of a single workshop and, with those variations, may be repeated for many centuries. On the whole one could not expect very much assistance from the stone vases in dating the graves and it seemed best to date the types by the graves in which they were found (as dated by the clay forms) and by their associations with each other; if these were consistent the general chronology of the cemetery would be confirmed and at the same time a basis laid for the chronology of the stone types. On the basis of the pottery dating then it was found that of the 58 stone types found in the graves four were found in graves marked as early, twenty-three in graves marked as late and thirty-one in graves containing only common types of clay vessels:<sup>1</sup> The proportion was consistent with the fact that stone vessels were most numerous in the middle graves, rather less so in the upper graves and much rarer in those of the lowest stratum; at the same time there were 28 types represented in the early graves, of which 24 continued in use throughout the cemetery period.

For dating purposes only the forms of the pottery vessels were taken into consideration; the graves having been dated by their means and the system confirmed by the agreement of the position of the graves and of the stone vessels in them, it is time to turn to an examination of the main wares and see what historical results their distribution amongst the graves can give. This is best done by a comparative table.

<i>Types of Ware</i>	<i>No. of Graves in which found</i>	<i>Early</i>	<i>Indeterminate</i>	<i>Late</i>
Plain painted red	17	7	7	3
Jamdat Nasr 3-colour	8	5	—	3
Red paint on light	4	—	—	4
Grey or black burnished	7	—	2	5
Reserved slip	6	3	1	2

The result was certainly not what I had expected (I had assumed that the Jamdat Nasr wares would all come at the beginning of the series) and at first sight it did not look very illuminating: when compared however with the data obtained from other sites it will be found to lead to quite definite conclusions.

In Pit F<sup>2</sup> the whole of the earlier part of the two periods under discussion is represented by the mass of pottery debris accumulated during the lifetime of the vase-factory which occupied the site and it is only for the latter part that we have stratified remains of buildings. As has been pointed out in Chapter II, the levels in the pottery stratum are not in detail trustworthy and their evidence must be accepted with a due amount of caution, but the general results are clear and can fortunately be controlled by the stratification at other sites.

<sup>1</sup>The consistency of the result can be illustrated by one or two examples; thus Type 13 was found in 13 graves of which 6 were late and 7 indeterminate; it was associated with 20 other stone types of which 4 were late and 16 indeterminate. Type 27 was found in 11 graves of which 6 were late and 5 indeterminate; it was associated with 20 other stone types of which 8 were late and 12 indeterminate. Type 30 was found in 7 graves of which 4 were late and 3 indeterminate; it was associated with 12 other stone types of which 7 were late and 5 indeterminate. Seven of the stone types are associated only with "indeterminate" clay types and may therefore belong only to the middle period of the cemetery.

<sup>2</sup>For a detailed description of the pit see Appendix I.

The pottery layer begins at *c.* 5.50 m. above sea level and the lowest metre contained virtually nothing but al 'Ubaid wares; in the next half-metre the plain red figures largely and there are two examples of red bands on a light ground. In the half-metre 7.00 m.-7.50 m., two-fifths of the decorated wares are of the plain red type, the red bands on light are no more numerous than before, twisted handles appear for the first time; in the next half-metre the plain red fragments are actually more than those of al 'Ubaid type, and between 8.00 m. and 8.50 m. about as numerous; by the 9.00 m. level the red wares had acquired a definite supremacy and above this such al 'Ubaid fragments as were found could be considered accidental.

The ware with red bands on a light ground continued in use but is always sparsely represented; above level 7.50 m. flat ribbon handles and reeded handles come side by side with the twisted handles of the half-metre below and impressed and scratched ornament on unpainted wares is found and in the layer 8.50 m.-9.00 m. becomes common. As regards the Jamdat Nasr ware, three pieces found just below the 9.00 m. level seem to have got there by the accidental disturbance of the soil seeing that none were found in the next half-metre above; but between 9.50 m. and 10.00 m. it was plentiful and was accompanied by the other type of ware found at Jamdat Nasr with red or brown paint on the natural body clay: in the next metre only one fragment of the polychrome decoration was found and the lowest of the building remains (building stratum H) which lay above the pottery debris contained none of it; on the other hand the next house, Building Stratum G, did produce a number of Jamdat Nasr sherds and was further characterised by an astonishing abundance of examples of the slender goblet of plain clay JN. 25 which did not occur in any other stratum; at Warka the same type is found in Layer II/III only and is there associated with the Jamdat Nasr 3-colour ware as it is in the Ur graves. Above Building Stratum G in Pit F Jamdat Nasr pottery is lacking and the industry seems to have vanished. Between levels 8.50 m. and 9.00 m. was found an example of the finely-burnished black Uruk ware, the only one recorded from the pit; stripe-burnished wares in light red or deep reddish brown first shewed at the 8.00 m. level and isolated examples continued above this up to 10.50 m., where it became less uncommon; at this level the first specimens of reserved slip ware made their appearance; the pottery with red bands on the light ground is now common, but the plain red forms the bulk of the decorated wares and continues after the disappearance of the Jamdat Nasr ware.

Comparing the results given by the pit and the cemetery it becomes at once clear that the Jamdat Nasr polychrome pottery is not a development of the wares previously in use but is superimposed on them; it has no connection with what went before and none with what came after; it is introduced suddenly, and when it comes in its style is already fully formed, it would seem to have been in use for a fairly long period,<sup>1</sup> and it went out of use suddenly and completely; during the whole time that it was in vogue the old-established wares continued to be made and after its disappearance they flourished still; such new types as were evolved in the interval were developments of the old styles and owed nothing to Jamdat Nasr taste or technique.

This side-tracking of the Jamdat Nasr culture, at least as regards its pottery, from the main line of development in Sumer is so important that the arguments for it may be yet further elaborated. Of the priority in date of the plain red and smother-kiln wares there is of course no question, but they occur together with Jamdat Nasr fabrics not only in the confused layers of our pit F but in the better stratified soil of Warka, and they are found actually in the same graves in our cemetery; there too the reserved slip and the polychrome wares are associated (in JNG/129, a late grave), and the fact that Jamdat Nasr pottery covers the whole cemetery period makes it contemporary with both the red and the black wares. It is curious that the ware with red paint bands on the light ground, which (at Warka as at Ur) is proved to be in its origin earlier than Jamdat Nasr, is found rarely in the cemetery and then only in later graves; it looks as if this had suffered by the competition of the more spectacular polychrome fabrics and after a long struggle came into its own only when its rival was relinquishing the field. As regards the reserved slip ware, the credit for it can certainly be attributed to the old school of potters; it is really an easy – and therefore cheap – way of producing an effect very similar to that of the ring-burnished pottery which again is older than Jamdat Nasr. It was not a local invention; it is found throughout the country and as far away as Carchemish, where it follows on a period in which elaborate ring- and spiral-burnishing had been the main decoration of clay vases; but like burnishing it is due to a technique which is using all the possibilities of its proper material and rejects help from outside, the antithesis of that of the painter on clay. The decorative effect of reserved slip is good but not striking and in competition with Jamdat Nasr the ware was not likely to be popular; it survived it however and in a succeeding period enjoyed, as will be seen, a wide market.

The fact then that all these wares were found together in the Ur graves, which at first sight was disconcerting and seemed likely to upset all chances of a rational sequence, is of great importance because it puts the Jamdat Nasr pottery into the right perspective. Inasmuch as it appears from the first fully developed and has no local antecedents it must have been introduced from outside, and its introduction should coincide with some important social or political happening, but it does not constitute or symbolise a complete breach in the continuity of history. We are justified in speaking of a Jamdat Nasr Period, the well-defined phase during which this foreign influence was paramount; similarly we may call the preceding pe-

<sup>1</sup>On this *v. infra*, p. 30.

riod when the red and black wares stood alone Uruk Period, but we must remember that the Uruk pottery continues in use long after the "Uruk Period" has come to an end.

Of the Uruk period we have at Ur virtually nothing to shew and indeed so far as our evidence goes it might be argued that the "period" was so unimportant as to be negligible; not only has it left no monuments of interest, but such remains as there are need not represent any considerable lapse of time. Between the top of the Flood deposit and the level at which the Jamdat Nasr age may be fairly said to begin there is an accumulation of four metres' depth of broken pottery of which the lower two and a half metres at least must be assigned to the period al 'Ubaid II and III: it is perfectly impossible to estimate how fast or how slowly the rubbish-mounds of potsherds were formed; the stratification such as it is does shew that they formed gradually and are not merely the result of the wholesale dumping of rubbish at one time; but even so the process need not have taken long and the chronological importance of it might with good show of reason be discounted. Actually the case is an interesting one as proving the danger of basing conclusions on the *data* of one excavation in one archaeological site. Corresponding to our post-Flood deposit at Ur there are at Warka the successive building-levels; in Warka layer XII the later al 'Ubaid wares are predominant, in layer XI they are less numerous and in layer X they are practically ousted by the Uruk pottery; we may fairly correlate this level with the level in our Ur pottery stratum at which al 'Ubaid III ends and Uruk begins: at Warka the Jamdat Nasr period comes in layers II/III, and there are therefore ten building periods to be attributed to the Uruk period which at Ur is represented by a metre and a half of potsherds. It is true that not all of the buildings in the Warka pit were of an important nature or necessarily long-lived; huge halls with massive columns all overlaid with coloured mosaics carried out in such painted terra-cotta cones as are found scattered amongst the potsherds in the Ur pit imply an age of settled prosperity, took long to build and presumably stood for very many years.

Such buildings of course existed at Ur also. Excavating on the Ziggurat terrace we found<sup>1</sup> below the Jamdat Nasr level sections of retaining-walls, an older wall and a later revetment added to it, built of the small oblong "Riemchen" bricks characteristic of the later Uruk period; they supported the platform of an older Ziggurat than that which stands today, and on the two clay floors of the platform corresponding to the two walls there lay thousands of mosaic cones which had adorned either the Ziggurat itself or its out-buildings; nothing remained *in situ* in the relatively small area covered by our excavation, and if standing walls of the time are preserved at all they would be underneath the Third Dynasty Ziggurat where work on a large scale could hardly be attempted by us, but the fallen fragments at least witness to the splendour of the Uruk Period at Ur as elsewhere.

One great innovation must, it would seem, be accredited to the Uruk people. The pottery of the al 'Ubaid I period is made by hand; it was turned round in the process of making, presumably on a board, and sometimes on a pivoted board, but there was no wheel. Of the al 'Ubaid II wares some is made by hand but many examples shew the use of the "slow wheel" which revolves but only at the rate at which it is turned by the hand. The earliest examples of the fine Uruk pottery are made on the true wheel and the al 'Ubaid III ware which is contemporary with and later than it is also wheel-made; the introduction of the wheel therefore is due to Uruk. The fact is very clearly shewn in the pottery stratum in Pit F; the lowest layers are hand-made or the products of the "slow wheel," the upper layers are exclusively wheel-made, even the clumsy "flower-pots" of Type JN. 2 are roughly thrown. In the upper part of the stratum, by one of the kilns found bedded in the sherds, were the fragments of an actual potter's wheel; it was a disk of baked clay 0.075 m. thick and 0.75 m. in diameter, heavy enough therefore to spin freely of its own momentum; the central pivot-hole was smoothed with bitumen (or perhaps the bitumen was for attaching a peg which itself revolved in a socket in the lower board) and at one point near the edge on the upper surface there were small holes into which would be put the stick-handles that served to turn the wheel.

That the invention was not utilised by potters only is proved by the finding of clay wheels belonging to model chariots; the actual chariot illustrated on Pl. 24 is of later date, but the wheels occur in the Uruk stratum, and that they were introduced by the Uruk people from the moment of their arrival at Ur is shewn by the discovery of a model wheel painted in the technique of the period al 'Ubaid III. The earliest picture of a wheeled vehicle that has been preserved is on a seal-impression U.13938<sup>2</sup> of the Jamdat Nasr age, where we have a war chariot not unlike that of the Royal Cemetery age; but the invention must be credited to the Uruk age and people.

One other individual object deserves mention here. Low down in the Uruk stratum in Pit F, at level 6.70 m., there was found a fragment of a clay vase modelled in the form of a bird (U.14958, Pl. 44). The zoomorphic vases are most important as betraying northern influence;<sup>3</sup> at Warka an example in stone has been found dating from the Uruk period, and though they seem to be more common in the Jamdat Nasr age,

<sup>1</sup> *Ur Excavations*, Vol. V, p. 5.

<sup>2</sup> *Ur Excavations*, Vol. III, No. 298 on Pl. 22.

<sup>3</sup> Frankfort, *Mesopotamia, Syria, and Egypt and Their Earliest Interrelations*, (Royal Anthropological Institute. Occasional Papers, No. 6), p. 113.

that can legitimately be explained as the result of an artistic tradition which has its roots in an earlier phase.

The kilns found in Pit F all come within the Uruk period; in the uppermost of them there remained the last batch of vessels put there to be fired and these were all of the "flower-pot" type JN. 2 which judging by the innumerable fragments was the main output of the firm; it is specially characteristic of layer V at Warka. The most curious feature was a puddling-basin constructed of very large bricks (0.44 m. x 0.16 m. x 0.10 m.) moulded in cement; cement bricks of a slightly smaller size were used in a second enclosure wall, and at Mereijib the bulk of the house walls were of cement bricks laid over a mud-brick platform, and at Warka too cement bricks have been found belonging to the same period. This use of cement is unparalleled in any later age in Mesopotamia; cement for wall-plaster was employed in the Royal Tombs<sup>1</sup> and after that seems to disappear altogether; a white lime mortar is occasionally found in buildings of the Third Dynasty and often in Neo-Babylonian work, but real cement so far as I know never.<sup>2</sup> Bricks of a very large size seem to belong only to the end of the Uruk period; before that the small "Riemchen" are most common (these we find also in cement, measuring 0.20 m. x 0.10 m. x 0.10 m., but the variety in the sizes of bricks during the period is considerable. To what extent the sizes are peculiar to different phases in the period we have no means of knowing—in a single building the bricks employed would usually be of the same dimensions but it is quite possible that two contemporary buildings might be of different bricks; but at Warka no two buildings of the same date have been excavated and at Ur we have to deal chiefly with individual bricks divorced from their context; only in the case of the two containing-walls of the early Ziggurat terrace, which are necessarily of different dates though not necessarily very far removed from one another in time the bricks are identical, and the fact may mean that for important State buildings at any rate standard sizes were recognised and might continue to be observed for a considerable while.

To our knowledge of the Uruk period, so magnificently illustrated by the discoveries made at Warka originally by Loftus and afterwards by the German expedition, Ur has contributed little more than details which help to explain its genesis and its relation to the periods which preceded and followed it; for the Jamdat Nasr Period we have much more and more important material.

#### The Jamdat Nasr Period

The site of Jamdat Nasr itself<sup>3</sup> contained, apart from a few scattered Neo-Babylonian ruins, remains of one period only, buildings with walls of small "Riemchen" bricks which produced the famous painted pottery and numbers of tablets inscribed in pictographic script: the buildings shewed traces of their having been destroyed by fire.

At Warka the layer II/III contains the remains of a temple building originally decorated with cone-mosaics and terra-cotta reliefs; it was built of mud bricks of the flat type measuring 0.215 m. or 0.26 m. x 0.11 m. x 0.06-7 m. This had been completely destroyed and rebuilt (the re-building constitutes Layer II) and in the new work are bricks measuring 0.34-35 m. x 0.17 m. x 0.10 m. Of the second building also very little was left and immediately over it came (Layer I) a building in bricks of the plano-convex type. The date of the layer was fixed by pictographic tablets found in it.

At Ur, in Pit F, the period is represented by a belt of potsherds about a metre and a half thick, in the upper part of which were disconnected remains of building-foundations, and by Building Strata H and G. Probably to the same period must be assigned Building Stratum F, because though no Jamdat Nasr pottery was found in the rooms yet the walls were constructed with flat bricks (measuring c. 0.21 m. x 0.11 m. x 0.07 m.) as were those of the strata below, whereas in Building Stratum E these have been replaced by the plano-convex variety. Building Stratum G shewed signs of violent and wholesale destruction and temporary desertion, the site being overlaid by a hard mass in which decomposed mud brick alternated with bands of water-laid mud; on the other hand the houses of Stratum F had been, in E, rebuilt on the same lines although in a different material and therefore seemed to stand in closer relation to what came after than to what had gone before.

Jamdat Nasr itself cannot possibly supply any evidence for the length of the period, for it affords no material for comparison. Warka does not suggest, or at least necessitate, any considerable lapse of time for its two buildings, though it must be borne in mind that temples, solidly constructed and carefully

<sup>1</sup>Vol. II, p. 231.

<sup>2</sup>For analysis of the bricks and wall-plaster, see Appendix VI, a.

<sup>3</sup>See Mackay, *op. cit.*, p. 226.

maintained, should enjoy a decent length of life: on the other hand it might be pointed out that the older temple at any rate seems to have been deliberately overthrown, and that might have happened at any moment after its completion. All three sites bespeak a violent end for the period: only the remains at Ur appear to witness to its longevity.

As regards Pit F, we have two, or three, superimposed houses of which the first and the last at least were well built with thick walls which in the natural order of things would have outlasted several generations of men,<sup>1</sup> and to this span has to be added that for which the lower ruins and the pottery debris are witness. It has already been shewn in connection with the Uruk Period how dangerous it would be to argue from a mere metre and a half of debris to a negligible period of time; it would be equally dangerous to assume that the accumulation of debris was uniform and that the depth of the present stratum ought to be interpreted in the terms of that other; but with a very moderate estimate the total length of the Jamdat Nasr age begins to take on considerable proportions. And the evidence of the cemetery is to the same effect. That falls entirely within the Jamdat Nasr period but, as has been shewn, can itself be divided by the character of the other pottery in the graves into three phases; there is a first phase characterised by a wide range of pottery types, a second in which some of those drop out of use, others persist, but no new types seem to come in, and a third in which while the types of the second phase are carried on, new shapes in great variety are introduced side by side with them. A steady development might progress quickly but here we seem to see in the craft of the domestic potter a flourishing period, a period of stagnation and decay and thereafter a period of recrudescence and invention, and the interval of stagnation has been long enough for the old types to have passed quite out of memory so that there is no picking-up of past threads but a start made with a new pattern. This certainly implies the passage of time. While then it is impossible to fix in terms of years the length of the Jamdat Nasr domination, we must recognise that it played a part considerable in time as well as of political importance in the early history of the land.

The Jamdat Nasr pottery has been sufficiently discussed already and other characteristics of the period can now be described. One vessel however, calls for special note. Just above the 9.00 m. level in Pit F there were found fragments of a small vase of white frit covered with a pale turquoise-blue glaze (U.14908) and in Building Stratum H square D6 fragments of another similar vase having impressed ornament on the shoulder, U.14422, Fig. 9,d, p.63; glaze beads are found at a much earlier period, but these are the first examples of the use of glazed frit for the making of vases and they imply not indeed the invention of a new material but a noteworthy extension of a previously known technique.

#### Metal Types

The graves of the Jamdat Nasr period were not productive of metal objects. No gold was found at all. Of silver there were two pairs of ear-rings, of the simplest type. Of copper there were two plain mirrors and two curious spoons with very long slender handles, simple rods of metal, and small oval flat "blades;" two or three pins and one possible needle and a fish-hook (Pl. 30, U.19875) were the only objects other than bowls. The bowls (v. Pl. 69) are all of simple forms (2-5) wide and shallow with out-turned rims for the most part, though JN.5 has its rim by exception curved inwards. They are of pure or nearly pure copper (v. the analyses, Appendix VI, c); this does not in itself constitute any proof for the character of the metallurgy of the period in general, for domestic vessels made by hammering would naturally be of copper even at a time when bronze was used for weapons and tools; since no weapons or tools were found in the cemetery the question as to the use of bronze alloys at Ur in the Jamdat Nasr time must remain open. The presence of arsenic in the copper is characteristic of Anatolian and



Fig. 6. JNG/40  
U.18556

Armenian ores; copper ore from the south, e.g., from Oman, is free of arsenic; consequently we can conclude that in the Jamdat Nasr period as in the al 'Ubaid period (v. Vol. II, *The Royal Cemetery*, p. 290, for an analysis of the spear-head U.14992) the sources from which copper was obtained lay in the northern mountains; this would support the argument for the northern connections of the Uruk people.

The metal most commonly found in the graves was lead. Very many examples of the tumbler form JN.1 were found, one or two flat dishes, JN.4, and one or two rounded bowls JN.6. These, like the copper

<sup>1</sup>As soon as the roof of a mud-brick-built house is destroyed and the rain can enter the walls from above, the latter rapidly disintegrate (I am speaking of countries such as Iraq; in Egypt mud-brick walls roofless and exposed may endure for many centuries), but as long as they are protected by the roof they are remarkably long-lived: even in North Syria, where the rainy season is much longer and more severe than in southern Mesopotamia, mud houses a hundred years old are common enough.

vessels, were made by hammering, but not necessarily in one piece; the base of the tumbler was sometimes soldered or sweated on, and in one instance at least was slotted into the walls thus (Fig. 6). The metal is unusually pure (*v.* the analysis, Appendix VI, c).

#### Stone Types

But the outstanding feature of the period is its use of stone. The fragmentary foundations in the top of the pottery deposit in Pit F and the foundations of the houses in Building Stratum H are of rough unhewn pieces of limestone, that coarse limestone which can be got from the upper desert some twenty-five miles away to the west. That the architectural use of stone does not begin with the Jamdat Nasr period is shown by the ruins of a great temple at Warka belonging to Layer V, i.e., to the Uruk age, and for temples it continued down to the end of the First Dynasty of Ur, although by that time the above work was reduced to a mere facing which preserved the conventions but served no real structural purpose; but to find it in private houses must surely mean an extension of the practice for which we have no evidence at any other time. Similarly stone vases had been made ever since the period of 'Ubaid I, but in the Jamdat Nasr age they become astonishingly common, the materials are most varied and while the simple bowls and vases were in everyday use amongst all classes of society (even the poorest grave contains one or two examples) for a richer clientèle and for the service of the gods the carver in stone was called upon to produce decorated vessels and even pure sculpture in the round. The graves have furnished us with specimens of the former; on Pl. 32, U.19745, which combines a faithful copy of a shell with the figure of a flying bat, is a *tour de force* of which only a master of technique would be capable; the little limestone cups U.18524 and U.20000 on Pl. 31 are roughly finished but excellent in design; in the latter the animals are turned out over the shoulder and project in high relief, almost in the round, a treatment which was to become a regular Sumerian convention. These are indeed direct precursors of such a masterpiece as the steatite cup U.18118 on Pl. 35. This last was found in the ruins of a Persian house where it must have been preserved as an antiquity, and its find-spot therefore has no dating value; judged on internal evidence it might belong to a time so late as the latter half of the third millennium, but it is absolutely in the Jamdat Nasr tradition and some authorities would now put it as early as the Jamdat Nasr period. The motive is the familiar one of the row of oxen, here treated in profile with the heads turned outwards and carved in bold relief, but to them are added the ears of barley which occupy the field above the backs of the animals. The limestone cups from the graves were meant for domestic purposes — one of them indeed shews the wear of constant use — but the steatite bowl must have had a votive character, judging from the conscious symbolism of its decoration. Grain and live-stock were the wealth of Sumer, the cuneiform ideograms for cattle and barley, read together, give the word "fertility," and what in other cases was mere ornament has here become a prayer translated into stone. Sumerian art was always more successful in its handling of animal forms than with the human figure, and in this bowl it is seen at its best. The rhythm of the composition, the skilful adaptation of the design to the shape of the bowl, the faithful rendering of the essential character of the oxen combined with a stylistic treatment which is really statuesque, these qualities merit for the bowl the term masterpiece; the surface finish also is admirable and corrects any false impression of the roughness of Jamdat Nasr stone-work that might have been given by the two limestone cups, though the fine cutting and polishing of the vessels U.19745, 19744 (Pls. 31, 32) etc., from the graves should be enough to prove good workmanship.

The most important example of dated Jamdat Nasr stone-carving found at Ur is the steatite figure of a crouching wild boar U.14459, Pl. 37, found in the top of the pottery deposit in Pit F. The figure is carved in the round, 0.12 m. long; there is a socket in the back and deep grooves in the flank which may have been for inlay, but may equally well have been for some kind of supports which gripped the stone and held the figure steady:<sup>1</sup> in the treatment a thoroughly formed artistic style admits none the less of such elements of naturalism as the curving-up of the upper lip over the tusks, and the modelling of the eye-socket is full of vigour; it is indeed the complex product of an advanced school of sculpture. This phase of Jamdat Nasr art is much more richly illustrated by the magnificent stone carvings, reliefs and sculpture in the round, discovered by the German excavators at Warka,<sup>2</sup> as also by the carved gypsum trough (originally from Warka) now in the British Museum;<sup>3</sup> here there is a quality of work which so far as we know was not to be surpassed until the time when the age of Sargon of Akkad had brought new influence to bear on Sumerian art.<sup>4</sup>

<sup>1</sup> On the analogy of the later goat figure from the Royal Tombs, and of the silver "boat" harp, one might suggest reed-leaves of gold or copper, the animal being represented in his natural setting of the marsh.

<sup>2</sup> E. Heinrich, "Kurzbericht über den Grabungswinter, 1933-1934, in Warka," in *Deutsche Forschung*, 1934.

<sup>3</sup> *British Museum Quarterly*, Vol. III, pp. 40-41 and Pl. XXII.

<sup>4</sup> On the innovations in style of the Sargonid period see my *Development of Sumerian Art*, pp. 97 ff.

The discoveries at Warka have enabled us to assign to the Jamdat Nasr age, or at least to the tradition of that age, various fragments of stone carving found at Ur in conditions not helpful to dating and illustrating styles which until recently we were not in a position to fix chronologically. Warka has made it clear that the Jamdat Nasr people excelled in the art of inlaying stone with shell, mother-of-pearl, lapis lazuli and carnelian; the technique was not necessarily their invention, and it continued in use at least to the time of Gudea, as is shewn by his splendid cup of steatite inlaid with mother-of-pearl now in the Louvre,<sup>1</sup> but it is eminently characteristic of their time. At Ur it is illustrated by a steatite mace-head, U.197, Pl. 35, found, like most of the following pieces, in the temple treasury of E-Nun-Mah; the simple decoration (from which most of the inlay is missing) is a replica of that found at Warka; the steatite bowl on Plate 36 is a restoration from fragments and boasts a more artistic design worked in white, red and blue on the dark stone background. How the tradition developed is shewn by the splendid fragment U.239, Pl. 35, which is of about the time of Gudea (*v. infra*, p. 52). A fragment of a large calcite vase on which was the figure of a lion advancing over rocky ground (U.2638, Pl. 36) is a poor thing in itself but suffices to prove that there did exist at Ur parallels to the great alabaster vase of Warka; two other stone vases with animal reliefs, U.210, 211 on Pl. 36, are more difficult to judge; the clumsy drawing, the queer schematising of the hair of the animals and the flatness of the relief give them a more primitive look, but the vase U.211 is of definitely Jamdat Nasr form, and probably both belong to this period. In view of the technical excellence of the stone-work from Ur and Warka, sculpture in the round, relief-carving, the decoration of stone vessels, the inlay of stone with lapis-lazuli, carnelian and shell, it is surprising to read that at Jamdat Nasr itself no decorative work in stone was found and that simple stone vessels were few in number and so clumsily made as to give the impression that the craftsmen had as yet small experience and little understanding of their material;<sup>2</sup> in the same way with stone beads, lapis-lazuli was entirely lacking at Jamdat Nasr and carnelian was rare and very roughly cut and even those in softer stones such as alabaster and limestone were poorly made; in the Ur graves, on the contrary, carnelian is the commonest material for beads and is often finely cut and polished – the curious lobed agate beads in the necklace U.19575 (Pl. 27) must have been most difficult to make – and lapis is not rare; while not nearly so good as the beads of the Royal Cemetery those of the Jamdat Nasr graves shew no lack of experience and of resource. That Jamdat Nasr itself was not a mere village is proved by the abundance of painted pottery – certainly a luxury product – and of written tablets, so that the quality of the stone-work there can hardly be explained by the poverty of the people; what is peculiar to Jamdat Nasr is that it is a settlement with no antecedents and so far as can be seen with no mixture of inhabitants. The explanation may be that under their domination the old local craft was greatly developed by craftsmen of the old stock, in other words that the abundance of stone-work and the excellence of its manufacture in the old centres of civilisation such as Erech and Ur during this period was altogether in the Uruk tradition, that it was encouraged by the prosperity which the Jamdat Nasr people brought but was not otherwise inspired by them, and that where the Uruk tradition could not make itself felt, as in a purely Jamdat Nasr town, the local stone-work was that of tyros in the craft.<sup>3</sup>

In the case of writing it is certainly true that the Jamdat Nasr people, though they used the script freely, did not invent it, for pictographic tablets have been found at Warka in Layer IV which precedes their advent.<sup>4</sup> The use of a seal need not necessarily imply a knowledge of writing, for seals can be and were affixed to other than written documents, but seal-impressions have been found at Ur of the Uruk period and at Warka going to the period al'Ubaid III. The remarkable collection of seal-impressions published by Legrain in Volume III of this series come from different strata of which the lowest, SIS 6-7, Pl. 82, is a little later than the Jamdat Nasr age; it lies above the bulk of the Jamdat Nasr graves in Pits X and W, is undisturbed by them and therefore later in date. It is true that towards the south-east end of Pit W and also at the south-east end of Pit X there seems to have been some disturbance as if a few of the later graves of the series had been dug into and through the stratum and were therefore later than it, but the evidence was not conclusive; in the first place the strata SIS 6-7 tailed away to nothing at the north-west end of Pit X and the rubbish which replaced it further to the SE was different in kind and not necessarily of the same date, the graves were mostly plundered and the disturbance of the soil above them might have been due to the work of grave-robbers some time after the burials had taken place, and the pottery in

<sup>1</sup>de Sarzec, *Découvertes en Chaldée*, Pl. 44, Fig. 2. There are of course post-archaic examples of the technique which do not concern us here.

<sup>2</sup>Mackay, *Jamdat Nasr*, *loc. cit.*, p. 289.

<sup>3</sup>It may even be that the Warka hoard is really of Uruk date. It was buried in a chamber built of flat bricks under a packing of plano-convex bricks, therefore at the very end or rather just after the end of the Jamdat Nasr period: but the objects, the contents of a temple treasury, were already old and perhaps very old; we know that such were kept in the temples for centuries; in the present case the finest of the vessels had been broken in antiquity and mended with copper rivets and continued in use only to be buried at the last when fashions had changed; whatever length we assign to the Jamdat Nasr period such a vessel, found in such conditions, could easily bridge it and go back in origin to an earlier age.

<sup>4</sup>Jordan, in *Abhandlungen der Preussischen Akademie der Wissenschaften*. Phil.-Hist. Klasse, 1930, No. 4, p. 46.



the stratum is for the most part not of the Jamdat Nasr type. The tablets found with the seal-impressions<sup>1</sup> are written in a script definitely more advanced than that of Jamdat Nasr and even allowing for the possibility that progress in writing was made more rapidly at Ur than at some places in the north must be considered as being later than the pictographic examples from Jamdat Nasr. The stratum is composed almost entirely of jar-sealings, fragments of clay jars and burnt brick earth, and the jar-sealings are all heavily burnt; the brick earth results from the disintegration of mud bricks which have been subject to the effects of fire. Signs of conflagration are always associated with the Jamdat Nasr remains, and the present stratum seems to consist of the debris of a building destroyed by fire, presumably of a building which was standing at the close of the Jamdat Nasr period. In that case its contents must be of the Jamdat Nasr age, but might well be later in actual date than the objects from the Jamdat Nasr site which have necessarily been our criterion for the culture of the time. As compared with the tablets seal impressions, which come from store-jars<sup>2</sup> kept in the cellars or treasuries of some temple or palace, have a much more archaic appearance and where they are inscribed the characters are pictographic, totally different from the semi-linear script of the tablets. Only to a limited extent could this be accounted for by the assumption that the vessels had been kept a long time in store and were already old when they were broken open and thrown away; the real reason is that the art of the seal-cutter was conservative, he was producing an object of art, not merely a utilitarian office stamp, and the decorative effect of the old pictographs appealed to him much more than did the newfangled cursive writing;<sup>3</sup> the seal-impressions illustrate a tradition older than themselves and are material essential for the study of Jamdat Nasr art. Some of the designs are of a type that does not seem to recur later—the intricate linear patterns into some of which hieroglyphs are introduced as elements of decoration are surely peculiar to the Jamdat Nasr period; others, such as the domestic scenes with byres and the milking of cattle, directly anticipate works known to us of the First Dynasty of Ur; apart from their great intrinsic interest they are a valuable witness to the continuity of art in Sumer.

Dr. Legrain emphasises the close parallel that exists between many of the Ur seal-impressions and those from Susa. This might of course, be due to direct Elamite influence exercised on Sumer by Susa, but it could, I think, be more satisfactorily explained by the Iranian origin of the Jamdat Nasr invaders. The fact that the seal is an intensely personal possession would account for the Iranian (Elamite) style being so much more obvious in this than in other fields of art; the stores from a temple or a palace would bear the stamps of the ruling aristocracy and would naturally betray their racial origin.

For the most part, as has been seen, the Jamdat Nasr period appears to be consistent with the general tradition of the country and of its material remains only the three-colour pottery stands out as peculiar to itself; but in one respect besides it is strikingly at variance with all that went before or was to follow after it. In the graves of the Royal Cemetery, and in those of all subsequent periods, the body is laid on its side, the legs slightly bent and the hands brought forward in front of the face, in the attitude of a man asleep. In the al'Ubaid period, as has been remarked, the body lies upon its back, rigidly extended, with the arms by the sides and the hands folded over the pelvis; of the Uruk period no graves are yet known, but judging from the change of attitude in the late al'Ubaid III graves due, presumably, to the influence of the new culture, the custom that was to prevail throughout later history had already been introduced. But what characterises the Jamdat Nasr graves is the fact that the body is laid upon its side with the backbone bowed and the head bent forwards, the hands before the face and the legs brought right up in front of the body and the knees bent so that the heels almost touch the pelvis; (Pl. 8, c, and Plates 54, 55); it is the "tightly contracted" as against the "lightly flexed" position afterwards current. It is true that in some of the later graves of our series this attitude is modified and the practice of the Jamdat Nasr people was becoming assimilated to that of their neighbours, but there can be no doubt that they brought this custom with them, and a difference in burial rites means a difference either in race or in religion or in both. That their religion should have been very different is improbable; whatever it might have been once, as soon as they settled in southern Mesopotamia they were bound to adopt its gods for the simple and sufficient reason that they were the only ones who enjoyed any influence there; religion was a local affair as much as was earthly kingship, and allegiance had to be owned to the ruler of the land in which you happened to be. Religion may and often does dictate the form of burial, but the details of burial tend to be thought the concern of the family and the race rather than of the outside gods; it is rather as such that they are tenaciously conserved, and men will cling to their old funerary rites even while they invoke for them new gods. The Jamdat Nasr pottery has no antecedents on Sumerian soil but does connect with certain foreign wares; still more emphatically does the ritual of the Jamdat Nasr grave speak for the incoming of an alien race.

<sup>1</sup>*Ur Texts*, Vol. II, *Archaic Texts*, by E. Burrows.

<sup>2</sup>A piece of cloth was tied over the mouth of the jar and over this was plastered a lump of clay on which the seal was impressed.

<sup>3</sup>The preservation in Egypt of the hieroglyphic script for monumental purposes side by side with the hieratic and demotic of every-day use is an exact parallel; the use of Roman capitals for inscriptions contrasts with modern handwriting in the same way.

## CHAPTER IV

## EARLY DYNASTIC PERIOD

## Part I: The Plano-convex Brick Period

The temple or palace of Jamdat Nasr, with its surrounding houses, was destroyed by fire;<sup>1</sup> at Kish a bed of ashes covers the Jamdat Nasr stratum;<sup>2</sup> at Warka the evidence of fire is interpreted by the excavators not as proof of destruction but as the relics of a cremation custom,<sup>3</sup> but the destruction of the buildings of the period is very thorough and may well have been deliberate; at Ur, in Pit F, the destruction comes in Building Stratum G and the stratum above this is still characterised by the use of flat bricks, though Jamdat Nasr painted pottery is lacking, so that the evidence is not decisive:<sup>4</sup> but on the whole it seems safe to conclude that the Jamdat Nasr period everywhere came to a violent end.

However complete the destruction of the Jamdat Nasr culture or people it need not be supposed that in every instance the changes were absolutely uniform and contemporary: it would be quite possible for a man building a house immediately after the revolution to employ the flat bricks to which he was accustomed instead of the new-fangled (and inferior) cake-shaped bricks of the new culture. For this is the distinguishing feature of an age which was to last until the middle of the reign of Entemena of Lagash<sup>5</sup> — the use in building of a brick rectangular in plan but rounded on the top, the top generally furnished with one or two deeply-impressed finger-marks or with a long groove, these being "frogs" to bond the mortar to the bricks; in most walls, but not in all, courses of bricks laid flat alternate with courses of bricks laid on edge and slanting either all in the same direction or in opposite directions in alternate rows (the most common practice is to have two flat courses, then four "herring-bone" courses, then two flat, and so on). For neither type of laying is the cake-shaped brick so suitable as the flat; the quantity of mortar required to fill the gaps between the rounded tops and the flat bottoms of the bricks is disproportionately large, in the process of construction the bricks would be ill balanced and inclined to slip with the giving of the soft mortar and the brick form made no difference to their appearance, but why the builder submitted to the imposition of so unhandy a brick it is impossible to explain. As a general rule the burnt bricks are less convex than those of crude mud, and in the latter there is considerably variety, ranging from the merely inconvenient to the ludicrous, but the flat brick which is the builder's ideal and had always been used in Mesopotamia vanished completely and the plano-convex in a more or less exaggerated form was employed without exception until early in the third millennium when it went out of fashion as suddenly as it had come in and as completely.

To the statement that it went completely out of fashion one curious exception must be made. In a seventh-century courtyard on the NW side of the Ziggurat the pavement was made of a mixture of plano-convex bricks and bricks of Dungi; the mixture probably means that this was simply a case of using old material which had come to light when the site was being excavated for the new building. But in an earlier Kassite shrine in the same neighbourhood there was found, buried under the wall and the pavement-edge as a foundation-deposit, a collection of miniature models in unbaked clay of plano-convex bricks, many of them incised with some religious symbol, and of the mixing-bowls used for the bitumen mortar: and in the boxes containing *papsugal* figures which were set for good luck below the floors of Neo-Babylonian buildings are as a rule made of ancient plano-convex bricks. To the use of the old type of bricks for the consecration of a new building some religious sentiment obviously attached: it may have been merely a reverence for antiquity as such, but possibly it was a distant echo of a religious scruple which had originally brought the plano-convex brick into common use. The survival, limited as it is, may give a hint as to the motive of the old builders when at the close of the Jamdat Nasr period they abandoned the excellent bricks of the past day for this architectural monstrosity: *tantum religio potuit suadere malorum*, and it was certainly no practical consideration that induced the change.

<sup>1</sup>Mackay, *Report on Excavations at Jamdat Nasr (Field Museum of Natural History, Anthropology Memoirs, I. 3)*, p. 226.

<sup>2</sup>L. Ch. Watelin, "Rapport sur les fouilles de Kish," in *Journal asiatique*, 1929, p. 103. Cf. *id.* "Essai de coordination des périodes archaïques de la Mésopotamie et de l'Élam," in *L'Anthropologie*, XLI, p. 265.

<sup>3</sup>Jordan in *Abhandlungen der Preussischen Akademie der Wissenschaften*, Phil.-Hist. Klasse, 1930, No. 4, p. 25.

<sup>4</sup>See above, p. 4.

<sup>5</sup>Such is the real duration of the "Plano-convex brick period." The present chapter deals with that period only up to the end of the First Dynasty of Ur; it was found more convenient to treat of the latter part, of which we have no buildings, in the following chapter, for there is a complete gap in our material between the close of the First Dynasty of Ur and the early Lagash period, and the latter is in many respects more closely related to the Sargonid age proper, which immediately follows it, than with the relatively remote past of the First Dynasty.

Dr. Jordan<sup>1</sup> has urged that the change could be due only to the arrival of a new element in the population coming from outside Mesopotamia, and has also suggested that the herring-bone style of bricklaying is reminiscent of the technique of builders in stone, so that the round-topped bricks would be copies of the small boulders which they had employed in their original home. In an elaborate study of the plano-convex brick Mr. P. Delougaz<sup>2</sup> adopts the same view<sup>3</sup> and adds the further point that the origin of the herring-bone technique must be looked for not in the high mountains but in the foot-hills; this he argues partly from the shape of the oval enclosures at Khafaje, which he compares to hill contour-forts, partly from analogies with modern stone buildings in the Mosul neighbourhood in which herring-bone laying of the stones is common:<sup>4</sup> he rightly rejects Professor Andrae's suggestion<sup>5</sup> that it is a survival of mat building on the grounds that the brick walls were always plastered and therefore the type of bricklaying cannot have had a decorative value.

That the plano-convex brick derives its shape from a stone original is at least not impossible; that it was introduced from abroad seems a natural deduction from the fact that there is absolutely no precedent for it in Mesopotamia; that it was introduced by force, i.e., by invaders and not by the gradual infiltration of a foreign element in the population would well account for its sudden and exclusive use.<sup>6</sup>

As against all this, there is at the beginning of the plano-convex brick period no other feature whatever that can point to a foreign invasion; on the contrary, so marked is its continuity with the Uruk period that one is more inclined to regard the Jamdat Nasr period as an interruption which now comes to an end and allows the indigenous arts and the old life of the country to develop on their own lines. In the type of building, in the sculpture, in the pottery, in metal-work and in stone-cutting, in the cylinder seals and in the writing there is progress, but no innovation; it seems incredible that a foreign invasion which revolutionised in so arbitrary and senseless a way that most conservative of things, the brick, should have had no effect at all on anything else in life. It is this continuity, forcibly brought out by the results of our work in Pit F and, more especially, in the Jamdat Nasr cemetery in Pit X, that makes me doubt the correctness of Dr. Jordan's view, which formerly I had accepted. The shape of the plano-convex brick and the manner of its laying may well be influenced by stone rubble or boulder construction, and to that extent it would be foreign, at least to the south country; but that it was introduced by foreign invaders cannot so easily be maintained: I am tempted to suggest that it is rather the trade-mark of a nationalist rising against the foreign yoke of the Jamdat Nasr people; their painted pottery could easily be suppressed, they had introduced little else, so far as we know, and that little could be dropped also; they had been great builders, following on the lines of the Uruk period before them, and since architecture was a native art and building must go on, the only way to break the Jamdat Nasr tradition was to invent a new material which should be the sacred symbol of liberty; and someone, perhaps familiar with stone construction, suggested the plano-convex brick. It would be a fantastic explanation, but not so fantastic as the brick. The length of time during which this clumsy substitute for a good building-brick was endured does to me seem to imply that there was a sanction, probably of a religious sort, attached to its use, an idea to which the later cult of the plano-convex brick gives support.

The suddenness with which the new fashion came in is shewn not only by the uniform appearance of the plano-convex bricks immediately above the Jamdat Nasr level at Kish, Warka and Ur, but also by one very important building at Ur in which the two types appear together. Below the Ziggurat terrace and terrace buildings of Ur-Nammu there survives a Ziggurat terrace, complete in its ground-plan, of the time of the First Dynasty of Ur, and below this again and serving in the main as a foundation for the later construction

<sup>1</sup>In *Abhandlungen der Preussischen Akademie der Wissenschaften*, Phil.-Hist. Klasse, 1930 No. 4, p. 18.

<sup>2</sup>*Plano-Convex Bricks and the Methods of Their Employment* (*The Oriental Institute of the University of Chicago, Studies in Ancient Oriental Civilization*, No. 7).

<sup>3</sup>But on p. 8 he says "this peculiar form was not made purposely to meet a special architectural need or even a particular technique of bricklaying. It came about naturally as a result of using a low frame varying from about 0.03 m. to 0.05 m. in height. Since flat bricks, so thin, would easily break if only sun-dried, there was good reason for leaving the surplus clay, so that the brick was much thicker in the center." If so, the whole question is solved and there is no need to look abroad for an answer. But deeper brick-moulds had been in regular use in Mesopotamia for centuries; why then not use such instead of changing to a shallow mould and having to pile on extra mud to make the brick strong enough for use? The plano-convex brick is not the accidental result of using too low a mould; the low mould was deliberately introduced for the purpose of making plano-convex bricks.

<sup>4</sup>The analogy is not altogether fortunate; Mr. Delougaz says "The pattern results from the use of a certain kind of stone, such as limestone or alabaster, which is easily split. The flakes, being fairly regular in shape, are usually set on edge." But such stones split to a flat face, and supposing that the Mesopotamian builders of this age derived their herring-bone style from the use of these materials, we are as far as ever from explaining the rounded shape of their bricks. In parts of Anatolia today it is not uncommon to see, especially in half-timber houses, large pebbles and small boulders, generally more or less oval in shape, used with mud mortar for filling up the spaces between the timbers, and these are often set herring-bone fashion: that, rather than the use of fissile stone, gives a possible origin for our brick-work.

<sup>5</sup>*Das Gotteshaus*, p. 83.

<sup>6</sup>Mr. Delougaz' suggestion that the old bricks may have persisted in use side by side with the new has no support in fact up to the present.

is a third Ziggurat terrace with its attendant shrines built just as the Jamdat Nasr period came to an end.<sup>1</sup> The massive walls (Pl. 10,c) are built with mud bricks of which some are plano-convex (0.19-20 m. x 0.13 m. x 0.06 m.), laid sometimes flat but more often herring-bone fashion, and the rest (in the lower part of the walls the great majority) are flat bricks of different sizes;<sup>2</sup> always laid flat: that they are strictly contemporary is proved by there being alternate courses of the two types. The chambers in the buildings have a solid filling of mud bricks for a pavement-foundation, and these bricks are exclusively plano-convex. It looks as if the builders of this Ziggurat terrace were using up their old stock of material and eking it out with new; when they came to the packing of the room floors (which would be after the walls were complete) the old stock was exhausted and only bricks of the new type were used.

According to this, the first work of the new regime was no less ambitious than the building of a new Ziggurat. Judging from the very scanty remains of the older period the new building was marked by a change in the orientation of the Ziggurat itself, and at Warka a similar change seems to have taken place at about the same time. Only a strong government in prosperous times would have embarked on work of such scale, and its rise to power was apparently accompanied by a religious innovation symbolised by the orientation of its temples: the thoroughness of the change, the destruction of old State buildings, the supersession of the flat by the plano-convex brick, the complete disappearance of the painted pottery, all seem to indicate that the old government had been violently overthrown and that the new power, in its determination to blot out all memorials of the past, was backed by a general sentiment such as marks the revolt of patriotism against an alien yoke.

Something of the same sort is perhaps to be read into the facts of the corresponding strata in Pit F. Building Stratum F contained houses constructed with flat bricks and, as has already been said, should belong to the Jamdat Nasr period unless we take the complete absence of Jamdat Nasr pottery to mean that it is of slightly later date and its bricks were either old stock or made by some conservative brick-maker; but the next stratum, E, is built of the new plano-convex material and yet is a replica of its predecessor—it would almost appear that the houses had been pulled down and rebuilt simply for the sake of using the new type of brick, and if that be an exaggerated deduction it is at least clear that the change in bricks did not involve any change in the life of the people, there had been no invasion bringing foreign customs and altering the way of living of the ordinary man: there had been certain formal changes which he adopted whole-heartedly, but he remained essentially the same as before: and in the new conditions old indigenous arts flourish more vigorously and exclusively. For with Building Stratum E we have the predominant vogue of the reserved slip pottery which during the past regime had been developed from the plain burnished wares manufactured long since. At Kish the ruins of houses built directly on the ashes of the Jamdat Nasr level yield fragments of reserved slip ware.<sup>3</sup> At Tell Asmar<sup>4</sup> in the lowest shrine yet dug, that in which the hoard of statues was found, the walls are of plano-convex bricks and the pottery is reserved slip ware; it is to be expected that the next level below will be found to be that of Jamdat Nasr. In our Pits W and X the stratum immediately above the Jamdat Nasr graves contains quantities of reserved slip ware and with it the inscribed tablets and seal-impressions which have already been mentioned;<sup>5</sup> other forms of decoration for pottery are plain or strip burnishing, gashed ornament, incised hatching and rope-moulding; all of these are represented both in the house ruins in Pit F and in the debris strata of the other pits (*v.* Appendix I).

A good idea of the pottery of the age is given by the large collection of vases from the second cemetery at al'Ubaid, published in Volume I of this series. In that volume, written when our knowledge of the early periods was very small, I argued on admittedly weak grounds that the graves, certainly early in date, could most reasonably be associated with the First Dynasty temple in whose vicinity they lay; apart from their position the only evidence was that one or two vase-types resembled those shewn on the First Dynasty reliefs, a resemblance which in a conservative country does not count for much: now a wider experience proves that the pottery is typically that of the time succeeding the Jamdat Nasr period and our best illustration of it,<sup>6</sup> at least in some of its aspects. The reserved slip ware is represented by good examples (Vol. I, Pl. LIV, b) and rope-moulding and gashed decoration also appear, and there was one example of a pot of red ware (Type JN. 130) with bands of deep purplish red in which I recognised a survival of an earlier type; but the cemetery seems to come not immediately after the close of the Jamdat Nasr peri-

<sup>1</sup>*Ur Excavations*, Vol. V, pp. 4-5.

<sup>2</sup>0.37 m. x 0.23 m. x 0.10-11 m., 0.34-5 m. x 0.23 m. x 0.10 m. and 0.20-22 m. x 0.13 m. x 0.085; the smallest of these correspond fairly closely to the earlier Jamdat Nasr bricks used at Warka, the middle size to later Jamdat Nasr bricks on the same site (c. 0.22 m x 0.11 m. x 0.06-7 m, and 0.34-5 m. x 0.17 m. x 0.10 m. respectively).

<sup>3</sup>Watelin, in *L'Anthropologie*, XLI, 1931, comparative table, p. 272.

<sup>4</sup>Frankfort, in *The Times*, April 5, 1934.

<sup>5</sup>The tablets are published in *Ur Texts*, Vol. II, *Archaic Texts*, and the seal-impressions in *Ur Excavations*, Vol. III.

<sup>6</sup>This rectification of the cemetery's date explains the many parallels between its pottery and that from Jamdat Nasr on the one hand and the post-Jamdat Nasr "A" graves and "Y" level at Kish noted by D. B. Harden ("A Typological Examination of Sumerian Pottery from Jamdat Nasr and Kish," in *Iraq*, I, i, p. 30).

od but a little later, for various types found in Building Stratum E in Pit F have dropped out of use by the time of the al'Ubaid graves; thus in the house ruins handled vessels are still fairly common and, what is more important, we find specimens of the plain red burnished ware and of the black smother-kiln ware, also burnished, which is the hall-mark of the Uruk period. At Warka also and at Kish the Uruk pottery is found after the close of the Jamdat Nasr age, so that the continuity of the old culture into the new period, interrupted only superficially by the three-colour painted ware of Jamdat Nasr, is fully established.

Other survivals are shewn both by the house ruins and by the rubbish in the SIS strata. Crude clay figurines of men and animals are very common, and so are clay wheels and models of chariot-bodies;<sup>1</sup> the fact that these are associated with the jar-sealings and tablets which are apparently thrown out from a temple store should mean that they are votive objects, not toys, and as has already been remarked, they occasionally bear inscriptions. With them occur numerous examples of rough hand-made model vases, miniatures which certainly look like toys—dolls' tea-sets—but may also be votive and clay objects which apparently are spinning-tops (Pl. 16, U.13749); all of these are found in the Uruk strata but now reappear in greater numbers than ever before.

Two examples of sculpture of the period were found in the rubbish in which the graves of the Royal Cemetery were dug. One, U.8472, Pl. 24, is a man's head carved in white limestone of which only the back is preserved; it is rough work and of interest only as shewing that human sculpture in the round does belong to the age—a fact now richly illustrated by the Tell Asmar discoveries. The other, U.8292, Pl. 24, is of unbaked clay, hand-modelled, a human head which judging by the socket-hole in the neck was intended to be fastened to a body separately made and perhaps of another material.<sup>2</sup> That the face was painted is shewn by traces of black round the eyes, and in this respect it resembles a terra-cotta head from Kish<sup>3</sup> which it resembles also in the curious treatment of the eyes, in the flatness of the ears, the relief of the arched eye-brows and the prominence of the jutting nose as against the receding, narrow and pointed chin. It is difficult to compare a work summarily modelled in soft clay with more formally executed sculptures in stone, but making all allowances for that it would seem that the clay head is less closely related to the contemporary sculptures of Tell Asmar than to the much later figures of the First Dynasty and Lagash periods in the South: possibly we have here an illustration of the greater continuity of tradition amongst a people more essentially Sumerian as opposed to that of the North where Sumerian culture prevailed but the population were to be called Akkadian and from the outset spoke a Semitic language.

In the house ruins stone vessels are fairly common; all are of the open bowl type. A plundered cemetery at Bussokheir near Tal Halawieh on the east bank of the Euphrates in the Nasariyah district from which clay pots and stone vessels were brought to us at Ur<sup>4</sup> belongs to this period, and here too all the stone vessels from Mereijib (*v.* Appendix I, p. 82) though in this case the material was so mixed as a result of the denudation of the soil that they must be used as evidence only with caution. In the al'Ubaid cemetery the bulk of the stone vessels are of the open bowl form, but there are five types of which three especially anticipate the wide range of splendid forms found in the Royal Cemetery. What is surprising here is the negative element. In the Jamdat Nasr period we have a great variety of stone shapes<sup>5</sup> of which more than twenty, apart from such things as lamps, which hardly count as vase types, are strongly individual; not one of them is found either at al'Ubaid or in the house ruins which immediately succeed the Jamdat Nasr age: the bowls, which are in a tradition as old as Uruk and even as al'Ubaid I, are found in ordinary use, but the more elaborate forms characteristic of Jamdat Nasr (*cf.* especially types JN. 53-60) seem to be deliberately boycotted and there is first (if we can trust our evidence) a limitation to those shapes which might be considered indigenous and later the development of new types which may indeed have been influenced by foreign models, as analogies with Egyptian stone vases would indicate, but at least had nothing in common with Jamdat Nasr.

Just as the evidence of the pottery shews that the al'Ubaid cemetery is later in date than Building Stratum E, so that of the pottery and stone alike shew that it is earlier than the Royal Cemetery at Ur. How long the gap was, it is impossible to say. The early plano-convex walls of the cemetery area and, in Pits W, X, Y and Z, the rubbish-stratum SIS 4-5 which is roughly contemporary with Building Stratum E, were covered over with fresh deposit of rubbish some four or five metres thick before the first grave of the Royal Cemetery was dug, but there is nothing in the rubbish itself to tell whether the rate of accumulation

<sup>1</sup>For a reconstruction of a complete chariot see Pl. 48, a. The component parts in the reconstructed group do not actually belong together, for these things are always found scattered in the rubbish, but they are contemporary. The pole of the car is new, made on the model of the poles in the chariot-scene on the mosaic "Standard" (Vol. II, Pl. 92).

<sup>2</sup>In view of the northern connections of the Uruk pottery it is worth noting that I have seen in private hands fragments of a statue from the Khabur district (Ras al'Ain) whose head, hands and feet were made separately, originally of clay, later of limestone and, in the final edition of the figure, of marble, while the body was of some other material, probably wood. The existence of such acrolithic figures would explain the disaster to the Philistine statue of Dagon (I Samuel, V. 4).

<sup>3</sup>Watelin, "Rapport sur les fouilles de Kish," in *Journal asiatique*, 1929, Fig. 4. A coloured drawing of the head, over-restored, was published by Langdon in the *Illustrated London News*, Feb. 8th, 1930, p. 213.

<sup>4</sup>*v.* Catalogue, Nos. U.810-830, and Pl. 13.

<sup>5</sup>*v.* Pls. 65-67.

was fast or slow. At Warka no evidence is forthcoming because the reconstruction of the Eanna Ziggurat and its surroundings by Ur-Nammu has destroyed most of the plano-convex brick building over the area covered by the present excavations; three successive buildings of plano-convex brick can be distinguished<sup>1</sup> and the building of the Eanna Ziggurat and two enlargements or reconstructions of it all fall within the same period, but although for the Ziggurat work at least we can fairly demand a long space of time, yet this must cover the whole of the plano-convex brick period and does not help us to estimate the interval between its beginning and the time of the Royal Cemetery or of the First Dynasty of Ur. At Tell Asmar the shrine in which the hoard of statues was found is roughly contemporary with our Building Stratum E and was apparently repaired, or reconstructed, three times within the plano-convex brick period, and in the fourth shrine were discovered metal vessels closely paralleling those from the Royal Cemetery; these probably were older than the building in which they were buried, so that we cannot attribute all the shrines to the interval of time between Jamdat Nasr and the Royal Cemetery but must spread them over the whole of the plano-convex brick period, unless it be suggested that plano-convex reconstructions at a higher level were removed to make room for the foundations of the Sargonid temple, a suggestion for which there seems to be no support in the evidence yielded by the site. At Kish the plano-convex brick temple can now with confidence be assigned to the early part of the period, if not to its very beginning; the figures cut in shell for inlay found in its ruins bear a striking resemblance to those from the Tell Asmar hoard and to the stone sculptures from the same level<sup>2</sup> and should be of much the same date, and further the palace was destroyed and into its ruins are cut graves (the "A" cemetery) which are later than the "Y" graves of the same site belonging to the plano-convex brick period and perhaps coeval with the palace but are earlier than the Royal Cemetery.<sup>3</sup> Here then we do get evidence of a considerable interval between the Royal Cemetery and the beginning of the period as represented by our Building Stratum E. To this interval we must assign Building Stratum D and perhaps also C, in which was found one type of clay pot not known in the Royal Cemetery; the extremely solid buildings of the latter stratum had been several times repaired and their floor levels raised, so that they may well represent a considerable period. The two higher building strata, B and A, would then correspond to the time of the Royal Cemetery; with this their pottery is thoroughly in accord, as is their stratified position below the level of the First Dynasty buildings in the adjacent mound EH (*v.* Section, Pl. 71).

The changes in art that took place during this interval are best illustrated by a comparison of the Tell Asmar statues with the objects from the royal tombs at Ur, but marked as the progress is the static element must not be overlooked. In Pit W, at the lower end of the SIS 4-5 stratum (Pl. 77) there were found four hooves of oxen (Pl. 29), made of thin copper hammered over wood, which had been fixed to a stand whose outlines could be distinguished; the animal had been represented very much in the attitude of the statues of oxen in the round found in the ruins of the First Dynasty temple at al'Ubaid;<sup>4</sup> in this case the body would seem to have been in some material other than copper, for it is difficult to account otherwise for the legs having been broken off all at so uniform a point: it is clear that not only in technique but in style the sculptures of the two very different periods must have been remarkably alike, and whether the hooves are to be attributed to the beginning of the plano-convex brick period or (since they were thrown away then) to the Jamdat Nasr age, they illustrate the conservatism of tradition in Sumerian art.<sup>5</sup> In the making of stone vessels there was, as has been noted, a great advance, but it is in the pottery that the change is most obvious. By the time of the Royal Cemetery all the old decorated wares have disappeared (two examples of pots of light clay with simple red paint bands alone were found) and together with the red and grey or black Uruk wares and the reserved slip ware there have gone also the twisted or reeded handles, ring-burnishing, most of the spouted vase types and nearly all the gashed and incised or combed ornament which was so common in Building Stratum E. Pottery has become plain and utilitarian, its place as an *objet de luxe* being taken by the vessels of coloured stone, or of metal; there is a break with the simpler traditions of the past which can be traced as a gradual process but is in the end absolute: after the First Dynasty of Ur even spouts disappear.

In the season 1933-34 there were excavated, in Pit X, ninety-five more graves of the Royal Cemetery; there had been more than double that number in the area, but the majority had been destroyed either by tomb robbers or by the intrusive burials of the Sargonid age. The detailed description of these is given

<sup>1</sup>*V. Abhandlungen der Preussischen Akademie der Wissenschaften*, Phil.-Hist. Klasse, 1932, No. 2, p. 9.

<sup>2</sup>Langdon, *Kish*, Vol. I. Pls. XXXVI-XXXIX. Frankfort in *Illustrated London News*, May 19, 1934, especially pp. 774 fig. 8, and 778.

<sup>3</sup>D. B. Harden in *Iraq*, I. i, pp. 30 ff.

<sup>4</sup>Vol. I, Pl. XXVII.

<sup>5</sup>Frankfort's suggestion (in *Archeology and the Sumerian Problem*, p. 16 n.) that in view of their resemblance to First Dynasty sculpture the hooves most likely belong to that period—"as graves of that period were dug into the seal-impression stratum, their presence would not be difficult to account for"—is not in accordance with the facts. At this point no graves came down within a metre of the top of the stratum, the stratum itself was absolutely undisturbed, and was nearly two metres thick, and the hooves lay almost at the bottom of it. Thanks to the bright red colour of the stratum, contrasting with the grey rubbish above and below it, the evidence was unmistakable.

in Appendix IV, p. 127; here the general results of the excavation alone need be recorded.

A few of the graves, chiefly those lying at the NW end of the area nearest to the main section of the Royal Cemetery, contained small gold objects, beads, rings and ear-rings, but such were exceptional; most of them had evidently never been other than poor. The stone vessels, though not uncommon, were of the simpler types and generally of stone of poor quality, and an unusual proportion of them had been in antiquity broken and mended with copper rivets; here, on the outskirts of the cemetery there was no such wealth as marked the central graves. One reason for the poverty of the personal ornaments was that, so far as could be seen, the vast majority of the graves were those of men, and these produced weapons in the shape of bronze axes, adzes and daggers in numbers far in excess of the average for the Royal Cemetery. Clearly these men were soldiers, armed with the regular weapons of the infantry as illustrated on the mosaic "Standard," and it would seem that the area covered by Pit X was the military graveyard of the time. Two peculiarities of the graves were worth noting. They contained a notably high proportion of large shell cylinder seals such as were found quite often in the other graves of the Royal Cemetery but not nearly so often as here; unfortunately, owing to something in the nature of the soil, most of them were hopelessly decayed and of very few could casts be made for illustration, but where the subject could be made out at all it was nearly always that of fighting animals (cf. Vol. X, Nos. 93, 134, 140, 142, 158, and 137 which is of calcite, not shell). Large shell cylinders of this sort, with similar subjects,<sup>1</sup> were found in the grave of Mes-kalam-dug, in the royal graves PG/1054 and PG/1236 (both those of kings) and in two graves distinguished by weapons, in one plundered grave which nevertheless contained a whetstone and therefore had probably had weapons, and in the grave of a man who was a scribe of the royal house. We have then a class of cylinder seals peculiar for their size, all made of shell all with the same symbolic subject—either a hero, or a lion, subduing wild animals—and they are found only in the graves of men and these may be kings or the officials of kings or they may be quite poor men but soldiers. I would suggest that these seals are really insignia, more or less equivalent to the war-medals of today, very much like the scarabs which were occasionally issued by Egyptian kings to celebrate their exploits.

The second peculiarity of the graves was that no less than three of them contained amulets in the shape of frogs. In the Royal Cemetery amulets were rare and most that we did find belonged to women; of frog amulets there were only two, one in a woman's grave and one in that of Mes-kalam-dug—a minute gold frog and another of mother-of-pearl were found, but loose in the soil, so that they cannot be taken as evidence. The link with the warrior Mes-kalam-dug is interesting: what connection with war the frog may have had I do not know, but it certainly looks as if it were a proper emblem for a soldier to carry; only a military significance will explain its presence in so many soldiers' graves.

In one grave, PJ/B36, a unique discovery was made. It was the grave of a soldier who, as usual, wore a dagger at his belt and carried a battle-axe over his shoulder: by his shoulder and actually touching the blade of the axe was an alabaster statue of a woman, U.19037, Pl. 37. In the whole of the rest of the Royal Cemetery no stone statue carved in the round was found. Figures of this sort, in which the subject is represented standing with clasped hands in the gesture of prayer or adoration, have generally been connected with temples and are votive figures symbolising the perpetual worship of the dedicator; but if the present statue was originally made to be an *ex voto* it was not used as such, for the objects in the graves were most definitely placed there for the service of the dead, not as offerings to a god. It is, as the lack of divine insignia shews, the representation not of a goddess, whose presence might sanctify the grave, but of a woman, and its position in the grave can be explained only by sentimental reasons. It would be going too far to argue on the strength of this one example that there was a regular domestic use for sculpture—that portrait-pieces were normally preserved in the house as well as dedicated in the temple—but the fact that this had so private and personal a context cannot be disregarded.

As the only example of stone sculpture in the round accurately dated to the Royal Cemetery period that we possess the statue is a valuable criterion for the style of the age. The sculptor had poor material to work on; the alabaster block was too short, so the statue 0.255m. high, is made in two pieces which were joined together by a wooden tenon; it was too thin, and so while in front the figure is properly in the round the back is very flat and where the hair should have projected in a chignon the stone failed and had to be eked out with plaster, which has now perished. The eyes are inlaid with shell and lapis-lazuli and a strip of lapis-lazuli surrounds the face to represent the fillet which kept in place the heavy hair; the eyebrows were cut out and filled with bituminous paste, which came away in powder when the figure was unearthed and could not be replaced, and the face and hands shewed, when first exposed, traces of red paint and the hair and the tassels of the sheep-skin robe preserved remains of black paint: we have therefore an example of polychrome statuary quite in the tradition of the Tell Asmar sculptures. The face has suffered somewhat by the decay of the stone; it is of the regular Sumerian type with sharply prominent nose, big cheek-bones, heavy oval outline, small chin and eye-brows which meet across the forehead; the short neck, wide shoulders and squat body are also characteristic, as are the rather narrow flat feet; the physical type is in most respects different from that given by the Tell Asmar figures and is probably more proper to the

<sup>1</sup>Vol. II, Pls. 196-7, Nos. 51, 54, 55, 57, 58, 59, 60.

south country. In technique the softer modelling and the higher degree of naturalism bring the statue closer to the works of the First Dynasty than to those of Jamdat Nasr; but it is curious to observe that the free undercutting of the stone, the separation from the main block of the arms and the absence of any "back pillar" to support the body which distinguish the Tell Asmar statues have here been abandoned and we have the more normal and less ambitious convention. To some extent this may be due to the material; the original block may have been too narrow to allow of extended elbows, just as it was too thin for the depth of the head, and the alabaster was of poor quality and the legs alone could scarcely be trusted to support the body; but whatever the reason the fact remains and makes more interesting the comparison of this with later and earlier works of art.

The only other objects in the graves calling for special mention are the copper pins on Pl. 29. In all the other graves of the Royal Cemetery only one pin of the sort had been found, decorated with a horned human head (U.13034, Vol. I, Pl. 231), but in this season three occurred, one with the horned head, one with a woman's head and one with the seated figure of a calf: the type is fairly common in the "A" cemetery at Kish which, as shewn above, is rather older than the Royal Cemetery, and although these may be merely survivals (for they were all found in one grave and so do not imply any wide diffusion of such pins) they may be evidence that the "military graveyard," in spite of its being on the outskirts of the main cemetery, does not belong only to its later phase.

#### The First Dynasty of Ur (E. Dyn I)

From the rubbish stratum SIS 1 which overlies the Royal Cemetery we have the seal-impression of Mes-anni-padda, the founder of the First Dynasty (Vol. II, p. 312) and seal-impressions and the actual seal of his wife Nin-Tur-Nin (*R.I.* 268); the al'Ubaid temple gave us the foundation-tablet, a gold bead and an inscribed bowl of his son A-anni-padda (Vol. I, pp. 126-7); U.11675, a fragment of a white calcite vase found in the rubbish above the Royal Cemetery bears the remains of an inscription which can be restored as giving the name of Meski-agnunna, the next king of the dynasty (Vol. II, p. 321, note 10). So far then as concerns the contemporary records of a royal house which prior to our work at Ur had been regarded as non-historical we are very well documented, but there is not a great deal to illustrate the reigns the reality of which is guaranteed by these scattered inscriptions.

The temple at al'Ubaid remains the principal and the only accurately dated building of the First Dynasty. At Ur itself we have the early Ziggurat complex described in Vol. II, Chapter 2; — the Ziggurat itself is buried beneath the massive brickwork of the Third Dynasty, but the surrounding terrace with its buildings is fairly complete. No inscriptions were found to prove its date; but as it was built above the terrace of the earliest plano-convex brick period and that at two removes, for the earliest building had undergone various modifications, it must belong to a fairly late phase of that period; and as it was itself modified by rebuilding at a higher level also carried out in plano-convex brick it does not belong to the latest phase; it can therefore with tolerable certainty be assigned to the time of the First Dynasty, when the elevation of Ur to the rank of the capital city of Sumer would naturally be accompanied by an ambitious programme of reconstruction. On the strength of this argument I attribute to the First Dynasty of Ur a number of objects found in the Ziggurat terrace buildings and described in this volume.

Over the greater part of the Temenos area excavation has not been carried down to First Dynasty level. Where this has been done the results have been disappointing. If there were buildings of that date above the Royal Cemetery site — there may have been funerary chapels, but probably little else — they have been completely destroyed and are represented if at all only by the rubbish stratum SIS 1. Elsewhere very little remained underneath the deep-set foundations of the Third Dynasty.

Against the outer NE wall of E-Nun-Mah there was found a pavement of plano-convex bricks, first remarked by Taylor in 1885. In the courtyard of the NW shrine of the great Gig-par-ku temple of Nin-Gal there were found walls of plano-convex brick resting on foundations of limestone rubble, presumably belonging to an important religious building of First Dynasty date; on the other hand excavation in the much-denuded area inside the "Cyrus" gate of the late Temenos produced only flimsy and ill-constructed walls of crude plano-convex brick which would seem to shew that in the time of the First Dynasty this part of the site was occupied not by temples but by houses of the poorer sort. Not enough of them was left — or excavated — to give any idea of the nature of the private house of that period; for such information we must turn to other sites such as Tell Asmar.<sup>1</sup> Even on the high-lying EH site the remains of plano-convex building were too disconnected to possess much interest (*v.* Appendix I and the plan, Pl. 70); but certain features would seem to shew that here there were religious buildings of which the tradition was, perhaps, carried on by the Nimin-tabba temple dedicated by Dungi. In Square P 8, below the foundations of the plano-convex

<sup>1</sup>*The Oriental Institute of the University of Chicago, Communications, No. 17.*



brick wall which we attribute to the First Dynasty period, there were two foundation-deposits, and in Square Q7 two more, of a peculiar type. Before the building started a hole was dug on the line of the foundations and on the earth at the bottom of it was spread out a piece of matting—the “table” of the modern dweller in tents: on this were set clay cups or saucers containing food-stuffs, we have identified grain and dates, the shoulder-blade of a sheep or goat, fish-bones and the bones of small birds, a meal representative of the natural products of the land: over this was inverted a great clay bowl, and the hole was filled up ready for the brick-layer. It is worth noting that in the Nimin-tabba temple we found under the pavement clay cylinders inscribed with Dungi’s name in which again there were small animal bones and food remains; the custom evidently persisted. A number of similar “tables of God” were found in the Royal Cemetery and actually in the shafts of royal tombs (e.g., PG/1054) where the idea of dedication is evidently the same.

The second peculiarity of the site EH was the number and type of the drains which it contained. Taylor, who excavated here in 1855, calls it “the Tomb Mound” and describes it as a mud-brick platform with no buildings on it, beneath which were numerous brick-built tombs and clay coffins; he emphasises the degree to which this “platform” was pierced by vertical drains made of clay rings, and supposes that they were intended to carry off the surface water from the cemetery and so preserve the graves from destruction by damp. Having failed to discover the existence of buildings—for which Taylor, a very careful observer, is not to be blamed, considering that the ruins were in mud brick and he was employing absolutely unskilled labour—he was hard put to it to suggest an explanation of the drains and hit upon one which is specious, but certainly wrong. All the drains were connected with buildings; many of these had disappeared owing to the denudation of the mound, but wherever the drain-top survived there were walls, or a floor, to prove that it had served a building: they were not by any means all of the same date, but ranged from Neo-Babylonian to the Plano-convex period, and therefore the number was not, in relation to any one period, so exaggerated as the total number visible at once in the confused field of ruins appeared; but even so they were out of all proportion to any reasonable domestic need.

The construction of the drains was simple. A circular hole about a metre or a metre and a half in diameter was sunk in the ground to the required depth, and then the drain proper was built from the bottom upwards with rings of terra-cotta placed one on the top of the other; each ring had small holes in the sides to allow the water to escape from the pipe into the surrounding soil, and to prevent the holes being blocked up by earth and the flow interrupted the space between the rings and the sides of the pit was packed with broken bricks and fragments of pottery. Thanks to this it is generally possible to date the drains with tolerable accuracy: the packing-material might be derived from some such source as the great rubbish-heaps of the Royal Cemetery site<sup>1</sup> and the packing might therefore be older than the drain, but a certain proportion of recent refuse was likely to be added, and as the pottery of the different periods is now fairly familiar to us a study of that surrounding a drain will give at any rate a *terminus post quem* for its construction even if it does not fix an exact date. Taking then only the drains which by their association with existing ruins could be attributed to the First Dynasty period we found their number grossly excessive. Pl. 11,a shews a mere slip of a room in Squares MN 7-8 measuring only 5.00m. x 1.25m., but in its brick pavement are two drains, necessarily contemporary; and in other cases drains of the same date lay close together. Now in a private house of the Larsa period two drains suffice for the whole building—one in the centre of the courtyard, one in the lavatory; it is exceptional to find a third. In the great Gig-par-ku complex of the Third Dynasty we know of three drains serving 87 rooms; in the palace of Ur-Nammu there are two, in E-Nun-Mah none, on the Ziggurat terrace two. Granting that these First Dynasty buildings were of a religious character, witnessed by the presence of foundation deposits, what possible need had they for so many drains?

Undoubtedly some of them were, like those of later date, merely drains—seepage drains which served latrines or carried off the surface water from the building sites: this is necessarily so where there is a horizontal lead going off into a vertical seepage-pit, as in Pl. 11,c, (v. also Pl. 2,b for an example from Pit F) or in the case of the little bath-room or lustration-chamber, Pl. 11,b; trumpet-mouthed tubes of terra-cotta, fitted one into the other, made up such leads, and very large tubes of the same sort (Pl. 11,d) might form the upper part of the vertical shaft. Even where the top of the shaft was in the chamber floor the drain might be of a purely domestic nature; occasionally the base of one would be filled with and surrounded by the greenish clayey matter which results from the decay of sewage. But in the majority of cases when the drain was excavated there were found inside it, at the bottom, numerous clay cups and saucers of the types RC. 4 and 7; occasionally with these was an example of the tall clay vase RC. 16, which is definitely a ritual vase for libations and clay models of boats; in a single drain there were as many as forty intact vessels and fragments of at least as many more. In the house-drains broken potsherds may be found, but not complete pots; one intact cup was found in a drain in the Gig-par-ku temple; at al ‘Ubaid, on the

<sup>1</sup>In excavating Pit X we obtained proof that the accumulated rubbish was a quarry on which builders drew for material for raising terraces etc., and the masses of pottery there would have served the drain-makers equally well.

lower terrace close to the foot of the temple platform, there were pottery drains precisely like these on the EH site and in them too there were found unbroken clay cups of these same types;<sup>1</sup> in Pit F some of the First Dynasty drains contained quantities of complete vases (v. Pl. 2,d). It would be absurd to suggest that mere accident could account for scores of intact cups being dropped down a drain, still more when this is found to have happened not once but in many cases, and most of all when in two out of the three sites (I exclude the drain in the Gig-par-ku, as only one cup was found there) the buildings with which the drains are connected are of a religious character. One is driven to conclude that the cups are *ex votos* or offerings dropped intentionally: and that being so the "drains" must themselves have a religious significance. The only explanation is that such shafts, going down deep into the ground, not indeed to water-level but on the way thereto, were channels by which offerings might be made to the gods under the earth, down which libations might be poured and food brought almost, as it were, into the presence of the god. There is nothing strange in the idea of pouring a libation to an earth god into a pit, a hole in the ground or a well; that in a built-up area the pit should be lined with the identical drain-pipes that served for domestic sewage would not shock the practical Eastern mind that looks to results and reckes little of means. From the texts we know of the existence of the *apsu*, the mysterious deep and dark place reaching down to the waters of the underworld and our shafts, though they do not go to water-level, do go well on the way thereto: there can be no doubt that they are to be identified with the *apsu* of Sumerian ritual, and when we find in the Gig-par-ku temple a similar drain in precisely the position where an *apsu* should be<sup>2</sup> the identification becomes a certainty.

### Objects

South-east of the Gig-par-ku temple lie house ruins of the Kassite period; at their south-west end the walls of these are stepped up sharply, and the reason for this was found to be that there runs beneath them here the ruin of a heavy mud-brick wall or embankment which judging by its relation to later works must be the wall of the First Dynasty Temenos. Lying against the inner face of this wall and at some depth below the Kassite floor there was a *cache* of objects all of First Dynasty date or thereabouts. The most important of them was a pair of limestone figures carved in the round representing rams (Pl. 38, U.6756 A, B). The animals are shewn kneeling, but whereas the heads and chests are fully carved the fore-legs are but sketchily indicated and the hind-quarters are left as shapeless blocks of stone; a round hole through the front shoulders was clearly intended to take a wooden bar; on the horns there were traces of black paint as also on the eyes, nostrils and hooves, and traces of yellow paint on the foreheads. The figures evidently formed part of a piece of furniture; they stood side by side and were joined by a low bar—only the front parts of them could be seen, but the nature of the furniture was such that the support of the stone was needed even where the backs of the beasts were hidden: the most likely explanation is that they were the supports of the throne of a god's statue (their height, 0.36m., would suit this very well) such as is pictured on many cylinder seals and reliefs. In spite of the difference in scale, material and purpose, the ram statues can safely be attributed to the First Dynasty on the ground of their stylistic kinship with the reliefs of cattle from the al 'Ubaid temple; the feeling for animal form, the subordination of realism to structural considerations and the artistic conventions are the same in the two groups. It is much more difficult to assign a date to another object found in the hoard, the little alabaster relief U.6410, Pl. 38. Like an alabaster relief from Tell Asmar<sup>3</sup> which is of early but uncertain date (it was found in a house of the Gutium or Third Dynasty of Ur stratum) it is silhouetted and carved in relief on both sides; even making allowances for the decay of the stone, the work is seen to be very rough and the design is crude. The carving represents a boat with high prow (the stern is broken away) and an arched canopy or cabin amidships; on one side a man (whose head is missing) is seen standing in the bows and in the cabin is a sow; on the other side the sow is replaced by a goose and the man by two fish which are tied together by a string passed through their gills and hang apparently from a peg. The stone in its present condition measures 0.06m. in length by 0.045m. The boat is not uncommon in scenes of Sumerian mythology—generally the boat in which the sun passes nightly through the underworld—but it would be hard to identify as religious symbols the creatures here represented, nor does the man, nude and with hands clasped in the attitude of adoration, rightly pose as a god; he is a human being, and his attitude suggests that he is the dedicator of the object, which I take to be an *ex voto* depicting the worshipper in the setting of his normal life, just as the *ex voto* of a ruler shews him at war or surrounded by his family. The boat is the reed-built boat of the marsh dwellers, as is clear from its form; the wild boar, the goose and fish are the staple products of the marsh-land: without straining after any mythological secret we can recognise here the sim-

<sup>1</sup>Vol. I, p. 70.

<sup>2</sup>Sidney Smith, "The Consecration and Induction of a Divine Statue," in *J.R.A.S.*, 1925, i, p. 37.

<sup>3</sup>*The Oriental Institute of the University of Chicago, Communications*, No. 17, Figs. 44 and 45.

ple man of the marshes who by a rudely cut memorial perpetuates his visit to the temple in the great city and the gifts of his hand that he brought with him for the gods.

The other objects from the hoard were bowls of copper, stone (Type RC. 48) and pottery (Types RC. 4, 108a, 145, 170, 194, 205, 206), a marble palette U.6488, the eye from a statue U.6586, two silver pendants, one set with lapis-lazuli, U.6797, Pl. 29, and one of filigree and embossed work, U.6800, Pl. 29; a smaller silver pendant from a necklace, U.6801, (*cf.* a gold example of the type in the string U.9656, Vol. II, Pl. 134), a silver finger-ring and about 900 beads in gold, lapis lazuli, carnelian and paste (U. 6795, 6796, 6798, 6802). Many of the individual objects are quite definitely in the style of the Royal Cemetery, and it might therefore be thought more logical to attribute the whole *cache*<sup>1</sup> to that period rather than to the First Dynasty: but the argument is not so strong as it appears. In the first place this is evidently a hoard of temple treasures, and there is therefore no need for all to be by origin contemporary. In the E-Nun-Mah, in a great collection of broken temple vases, the specimens dated by inscriptions covered some four centuries, from Sargon of Akkad to Ibi-Sin of the Third Dynasty: in the same temple under the Nebuchadnezzar pavement was a hoard of jewellery some of which was Neo-Babylonian, some Sargonid and some of the time of the Royal Tombs. Even outside temple treasuries survivals of such things as jewellery are probable enough. In our Sargonid graves, which are dated as such by inscriptions, no beads at all of distinctive Royal Cemetery type were found: on the other hand Frankfort has found beneath the floor of an Akkadian palace at Tell Asmar a hoard of jewellery<sup>2</sup> of Royal Cemetery style which, whether it belongs to the palace or to the lower stratum, is at any rate as a hoard much later than the Royal Cemetery, and Watelin found at Kish<sup>3</sup> a typical "dog-collar" which also Langdon dates to Sargonid times. It is quite possible that the fashions which I have taken to be exclusively those of the Royal Cemetery period were still current, or were revived, in later times; it is highly probable that examples of those fashions were preserved not only by temple treasurers but by private citizens for many generations exactly as is the case today, and it is the latter theory that accords best with the existing evidence. Of the objects in our *cache* then I should consider the two rams typical products of the First Dynasty, the beads and silverwork and probably also the alabaster relief as things already antique which were part of the temple's heirlooms.

A second *cache* was found in a clay vase buried in the floor of the courtyard on the north-west side of the First Dynasty Ziggurat terrace, behind the shrine in which the food of the gods was cooked. Most of the objects are figured together on Pl. 38. U. 17832, a calcite figure of a seated bull, 0.17 m. long, has in the middle of its back a square hole which is clearly the socket for something that stood on the animal's back, probably a small statuette of a god; it is good work, but the muzzle has suffered somewhat by the decay of the stone. U.17833, a seated figure of a dog (?) was originally painted red and the eyes filled in with black: a hole is pierced from the crown of the head to the stomach and on the under side is a design of animals roughly engraved (most of the cutting done by the drill) now so perished as to be scarcely recognisable; it is therefore really a seal. The little calcite figure of a calf, U.17834, is probably an amulet: the two lions' heads, U.17835 A and B, which are both pierced for suspension and were originally painted red, are also stamp seals, their lower surface being flat and roughly engraved with the drill-point with a design of animals: one is badly decayed. The little calcite figure of a human being, very summarily treated, U.17841, is, so far as my knowledge goes, unique: it is curiously unlike anything in Sumerian art. Together with these figures there were a bell-shaped object in white calcite (U.17836, Pl. 15) which recalls the 'Eye-idols' from Brak<sup>4</sup> (it is unique at Ur), a toilet-pot of white calcite in the form of two small vases joined together, this being in the Jamdat Nasr style, and a miniature vase also of calcite, two copper razors (U.17839, Pl. 30; the second was fragmentary) and a copper mirror U.17840, as well as a collection of 745 beads (U.17842) of lapis-lazuli, carnelian, shell, crystal, quartzite and glazed frit, none of them of very distinctive shapes. Here again dates may vary: the cutting of the seals on the lions' heads and on the dog certainly looks archaic, both occur in the Jamdat Nasr period, and the fact that all of them are much worn would point to their having been in use for a long time; the seated bull however and the little calf amulet are quite in the style of the First Dynasty and probably belong to the period.

Definitely of First Dynasty date are the two limestone figures for inlay U.18309 and U.11400, both on Pl. 39. The first was found against a wall of the shrine in the east corner of the First Dynasty Ziggurat terrace and must have been part of the decoration of the building; the second, found in the filling of the great courtyard of the Nannar temple in front of the Ziggurat, comes, judging from subject, from the same scene and the same place; it was evidently a boating scene and one man is propelling the boat with a punt-pole and the other, kneeling, seems to hold the steering-oar. The figures are precisely of the type

<sup>1</sup>That the objects were placed here deliberately is shewn by the fact that many of the clay vessels had clay cups inverted over their mouths.

<sup>2</sup>*The Oriental Institute of the University of Chicago, Communications*, No. 17, Fig. 29.

<sup>3</sup>Langdon in *Art and Archaeology* XXVI. 5, p. 155. The evidence is not very clear.

<sup>4</sup>Mallowan, in *Iraq*, Vol. IX, Pls. XXV, XXVI, LI.

of those in the al'Ubaid temple frieze<sup>1</sup> and must have been mounted in the same way against a background of black shale or slate; the parts of the limestone not meant to be seen, i.e., the background between the legs and between the arm and body being blacked out with bitumen; the figures themselves were probably painted. The fact that one of the figures was found almost *in situ* proves that the rich decoration of the al'Ubaid temple was not in any way unique but rather characteristic of the temples of the time: two other fragments of inlay (U.18313 and 18314, Pl. 44) shew that the decoration might be much more ambitious than the al'Ubaid friezes. These are steatite carvings of hair which were applied to figures in low relief of about one third of life size; the figures themselves were probably composite, made up of different materials, and one can only imagine a form of decoration much more magnificent than anything that has yet been found. That the First Dynasty was fond of composite figures is shewn by U.18338, Pl. 27, a miniature wig delicately carved in dark steatite, which also was found in the east shrine of the Ziggurat terrace and in the same room as the inlay fragments; it belonged to a little figure carved in the round, and judging from examples we have found the face would have been in shell, the drapery metal set with lapis-lazuli.

The richness of mosaic in the First Dynasty buildings is further illustrated by fragments found in the Ziggurat terrace temple; a number of pieces of shell cut in strips are engraved with the conventional "mountain" pattern, the double incised lines of the curves filled in with black paint and the central row

of curves done in *champlevé* and filled with red (U.17625 and U.18260, Pl. 44); there were also shell pieces with the fleece pattern from the *kaunakes* skirts of inlaid figures, and fragments of thin sheet gold probably the plating of wooden furniture (U.18226, 18236), these perfectly plain; a gold handle (?), U.18324, Pl. 30, is the only example of real goldsmith's work of the First Dynasty that the site produced.

Some of the amulets on Pl. 28 are, judging by the spots in which they were found, of First Dynasty date; the seated bull U.6486, although it closely resembles work of the Royal Cemetery (and of course may belong to that period) was found in the First Dynasty ruins on Site EH, as was the little lion, U.6504, and also the human leg U.6487; the tortoise on Pl. 27 (U.18352) comes from the shrine on the Ziggurat terrace and is accurately dated. From the First Dynasty level on EH comes a most interesting object, a die (U.6551); it is of bone, five millimetres cube, with lightly incised dots which are now in part obliterated so that the order of the

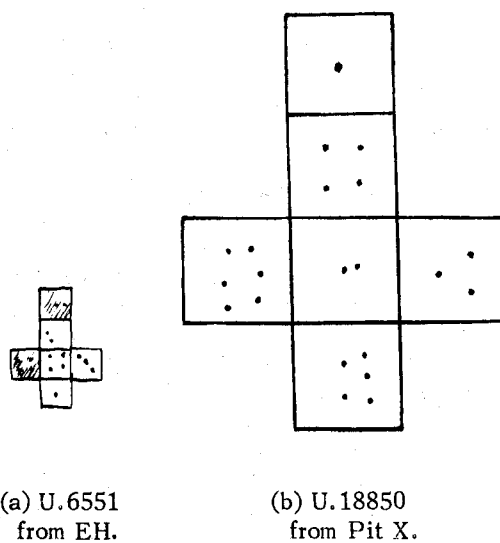

Fig. 7. Scale  $\frac{4}{5}$

the numbers is not clear (v. Fig. 7,a); a second die, of grey pottery, eighteen millimetres cube, U.18850, was found loose in the soil in Pit X, at level 14.00-15.00 m.; its date is therefore uncertain and may be anything between the First Dynasty and the Third, but it serves to complete the former specimen as the order of the numbers, dots made by pressing a sharp point into the soft clay, is preserved (Fig. 7,b). These are perhaps the oldest known examples of dice of the modern type.

## Part II: The Lagashite Age

For the long period that elapsed between the collapse of the First Dynasty of Ur and the accession of Ur-Nammu as founder of the Third Dynasty there are no buildings to shew at Ur. Records of building operations by various kings do exist, but no material trace of such has been found: with the exception of the work on the Royal Cemetery area and on the Ziggurat terrace excavation has been so strictly limited by our general programme to the sites of historic date that no walls assignable to this difficult and important period have been brought to light. Such monuments as we possess are for the most part isolated examples of sculpture or inscriptions that have been unearthed by chance, divorced from their proper setting, objects which had been dedicated in temples and so were preserved in the treasuries of the god long after the original buildings themselves, which being inscribed on stone or on the equally imperishable baked clay were scattered but not altogether destroyed with the dismantling of the walls wherein they were hidden. The age

<sup>1</sup>v. Vol. I, Pls. XXXI-XXXIII.

of Sargon of Akkad is further illustrated by the cemetery of which the greater part was published in Volume II of this series and a number of other graves in Appendix IV of the present volume. Most of the inscriptional material, in so far as it bears on the vexed history of the period, has been dealt with already by Mr. C. J. Gadd,<sup>1</sup> but must here be summarised again in connection with monuments of another sort.

A fragment of a calcite cup found in the ruins of Dungi's temple of Nimin-tabba on site EH bears a dedication<sup>2</sup> by the daughter of one AN-BU, who may be identified with the An-bu given by the King-lists as the founder of the dynasty of Mari; in that case it is in date the earliest inscription we possess subsequent to the First Dynasty of Ur. The statement is enough to shew how scanty is our historical knowledge. Between the First Dynasty of Ur and that of Mari the King-lists place no less than six dynasties, one of which is the Second Dynasty of Ur, and of none of those have we found the slightest vestige. Gadd suggests,<sup>3</sup> as pure conjecture, that of the four nameless kings of the Second Dynasty two might be Lugal-kigub-ni-du-du and his son Lugal-kisalsi, of whom inscriptions were found at Nippur giving them the title of "king of Erech and Ur," and fragments of a calcite vase with an archaic inscription<sup>4</sup> found in the temple E-Nun-Mah may have been dedicated by Lugal-kisalsi (the name is doubtful); but these kings may quite well have been kings of Erech not mentioned in the King-lists and belong to a later period. The six dynasties of the King-lists are vague and must largely overlap, so that the gap in time between the First Dynasty and that of Mari would be by no means so long as they would imply; but long or short it is a gap over which a possible Lugal-kisalsi affords but a poor bridge.

AN-BU's daughter bears a name Nin-me-ta-bar-ri which seems to contain a hieratic element<sup>5</sup> and may denote that she was a priestess; the custom whereby the daughter of the reigning king became High Priestess at Ur was a common one,<sup>6</sup> and were Nin-me-ta-bar-ri a priestess her dedication of the vase would be but natural. In connection with that custom, though not with any particular holder of the office, must be cited a remarkable limestone plaque found in the ruins of the temple of the Moon goddess Ningal. The relief (U.6831, Pl. 39) shews two scenes of religious ritual: in the upper, a man wearing a head-cloth kept in place by a fillet<sup>7</sup> but otherwise naked bends forward and from a tall spouted jug pours a libation into a vase of the type of our Royal Cemetery clay vase 16; the vase is set on the ground in front of the seated statue of the god who wears a plain heavy skirt, leaving the upper part of the body bare, and a flat crown such as appears on our shell plaque U.2826, Pl. 38, on reliefs of the time of Ur-Nina and on Eannatum's Stela of the Vultures; in both hands he holds a vase. Behind the ministrant come three smaller figures all enveloped in heavy cloaks and wearing the same fillet (and probably the same head-cloth) as the leading figure; their hands are clasped in the conventional gesture of devotion. The small scale of these figures and the analogy of the Ur-Nina reliefs shewing similar scenes but elucidated by inscriptions make it tolerably certain that they are the children of the ministrant and that he is the king, here fulfilling his double *role* of king and priest. In the lower scene the action takes place not in the sanctuary where the god's image was set up but outside it; the building is represented by its arched door set in a triple frame and flanked by the regular spear-headed uprights with half-circular projecting loops;<sup>8</sup> before the door is set a vase similar to that in the upper scene, but while from the rim of the latter there hangs down a shapeless and unrecognisable object here there are on each side pendant rings; by later analogies one would expect here bunches of dates, but these are apparently swing handles of twisted cord: on either side of the vase are piled what may be loaves of bread. Pouring his libation into the tall vase stands the ministrant, a man in the same attitude as the king in the upper scene, but wholly naked, his clean-shaven head not covered by head-cloth and fillet; he is the Sumerian priest, not the king. Behind him stands a curious figure whose head and body are drawn full face and the feet in profile; it is a woman wearing a skirt and a heavy sleeveless cloak and a flat cap (or else a very heavy fillet) from which two long tresses of hair escape to fall down upon her shoulders; her hands are clasped in devotion. Behind her advance two figures, both fully draped and both apparently women, of whom the foremost carries a goat for the sacrifice and the sec-

<sup>1</sup>*History and Monuments of Ur*, Ch. III.

<sup>2</sup>*Ur: R. I. No. 12.*

<sup>3</sup>*Op. cit.*, p. 77.

<sup>4</sup>*Ur: R. I. No. 3.*

<sup>5</sup>E. Burrows, in Vol. II, p. 321.

<sup>6</sup>As in the case of Sargon, Kudur-Mabug, Nabonidus; so important was the religious position—or the financial control associated with it—that, perhaps in cases where no daughter was forthcoming or the post of priestess was already filled, the son of a reigning monarch would take the priesthood; this was done by the son of Ur-Bau of Lagash (*v. infra*) and by Eannatum son of Ishme-Dagan king of Isin.

<sup>7</sup>Like the head-cloth and *brim* of the modern Arab, and that worn by the courtiers of the time of the Royal Tombs (*cf.* Vol. II, p. 243). This seems much more likely than that the man's own hair is meant to be represented falling in a mass on his shoulders.

<sup>8</sup>The meaning of the looped uprights, which were so stereotyped that they symbolised an entrance even where the door itself was not shewn, has been much discussed; personally I am inclined to regard them as the rings of leather or metal in which the hinge-post of the primitive door turned. Later at any rate they became purely conventional; at Ur there has been found what seems to be an actual example of such a ring made of stone. *V. U. 6463*, and p. 78.

ond an unrecognisable object: these are servants. If the principal figure in the top scene is almost certainly the king, it is at least equally likely that the principal figure in the lower is not the ministrant priest but the woman for whom he performs the actual libation, the high priestess and the daughter of the king; the scene is an exact parallel to that which will be illustrated later, where Sargon's daughter witnesses the act of libation performed by a subordinate priest. The general character of the plaque (which was intended to be fixed to the wall of the shrine by a peg passed through the hole in the middle of it) is altogether that of the Ur-Nina reliefs, and the style of the god's crown, as noted above, further fixes its date to somewhere near the Ur-Nina age. In judging of it as a work of art one has to remember that much that seems rough would have been disguised originally by paint; a mere scratch across the god's skirt shews where the baldric was to pass (*cf.* U.2826, Pl. 38) and the feathers on his crown are not even sketched; many of the details now not certain, such as the nature of the object hanging from the rim of the vase in the top scene, and the head-dresses or hair of the figures, would have been perfectly explained when the whole plaque was completed in colour. But although we have but the ground-work for the finished object it none the less compares very favourably as a work of art with the Ur-Nina reliefs; this may be due to a difference in date, in which case the plaque is here treated not quite in its right place and would have to be assigned to a period rather later than that of Ur-Nina himself; but the contrast is more likely due to the notoriously provincial character of Lagash at that time; both in its sculpture and in its script the Lagash of Ur-Nina would seem to have suffered from a set-back, or from arrested development, which makes its products appear much more primitive than their date warrants and is a pitfall in the way of comparative chronology.

This aspect of Lagash art is well illustrated by the stela U.17829 on Pl. 39. It is of mottled red, black and white granite, and the material was evidently too hard for the sculptor to cope with by ordinary means; instead of being cut, the relief is made entirely by the rubbing-down of the stone, and as a result there are no definite outlines but only shallow curves from whose gradations of light and shade vague figures faintly emerge.<sup>1</sup> On the back is a scrawled inscription of which there can be read only the names of Ur-Nina and his grandfather—his father's name and that of his city Lagash have been hammered out. On the face is a draped figure wearing the horned cap of divinity and holding a disk (perhaps a plate), seated on a pile of corn; it is probably the goddess Nidaba.<sup>2</sup> Behind her, reaching only to her shoulder, is an attendant armed with what may be a fly-whisk. On each side of the stone is a single figure, one clearly a second attendant carrying a vase, the other (whose head is missing) would appear from the tasselled girdle that falls down the front of his skirt to have been a person of greater importance, possible the king himself. As a work of art the relief cannot claim our admiration, but as a historical document it is of real value because after a long period of surmise and blank ignorance it brings Ur into touch again with known characters. Ur-Nina's exact date is not known, but he reigned somewhere about 2,500 B.C.; he does not appear in the King-lists, so presumably could not claim the overlordship of the country, but the presence of his monument at Ur is sufficient evidence that he had made himself master of the city. Nor was it a mere raid that enabled Ur-Nina to set up his trophy; for five generations at least, and after an interval for another eight generations, Ur was to be in subjection to a city which was not even the capital and whose rulers for all their wealth and their boast of conquest were passed over in silence by the Sumerian annalists. The effect of the Lagash influence is seen in the small shell plaque U.2826, Pl. 38, already referred to; contrasted with the shell engravings from the Royal Cemetery it is crude in the extreme, but it bears the closest possible resemblance to Ur-Nina's work; incidentally we have here the curious convention whereby the width of the body was grotesquely exaggerated at the expense of its height; this does not appear in the earlier work from Ur, e.g., the mosaic "Standard," but is characteristic of Lagash and influences even sculpture in the round. On the shell plaque two figures advance together, one holding the other by the wrist; both wear long cloaks and feathered crowns adorned with bulls' heads and the leader has a double baldric crossing his body in front and carries in his right hand a slender rod; both have long hair of which one lock is brought over the shoulder while the rest falls down the back in a heavy mass; presumably they are a god and goddess such as are represented hand in hand, or embracing each other, on terra-cottas of the Larsa age.

To somewhat the same period we may on grounds of artistic style and script<sup>3</sup> assign a very fragmentary and much battered relief in grey limestone figured on Pl. 41 (U.6691). In an upper scene are three figures advancing to the right, all wearing the fleeced *kaunakes* garment fastened over the left shoulder, leaving the right shoulder bare and falling to just above the ankles; their hair forms a heavy chignon resting on the nape of the neck and the central figure seems to wear drop ear-rings. These are male

<sup>1</sup> The grain of the stone together with the character of the relief made the photographs useless; to obtain those published on Pl. 39 a wet squeeze was made of a single sheet of paper and, this being held in a strong light, the shadows were emphasised with black crayon.

<sup>2</sup> *Cf.* Legrain in Vol. III, p. 361, on the cylinder No. 355, Pl. 214.

<sup>3</sup> *Ur: R.I.* No. 13.

figures. In a lower scene was a similar row of women; they wear a garment of pleated linen close-fitting round the neck and leaving at least the forearm bare (it may have been sleeveless altogether) and their hair is fastened at the back but loosely so as to hang in waves over the ears; each raises her right hand to her head. The inscription records the pious acts of a king whose name has perished "the . . . he enlarged, the E-a-na-ka he enlarged," a list of his building activities with which the figures of the relief would seem to have little to do, but for that very reason, since the grouping becomes conventional, it enables us to restore the plaque with tolerable certainty; at the right hand end would have appeared the king, his figure either repeated in the two registers or on a large scale occupying the two; the figures represent his sons and daughters, the former wearing the garment which is pre-eminently the emblem of royalty. Here then is a replica of the familiar Ur-Nina panels and a further testimony to the influence exercised by his house on the fortunes and the modes of Ur.

Two other pieces of sculpture though they bear less obviously the hall-mark of the early Lagash period may reasonably be assigned to it. One, U.6727, Pl. 41, is a fragment again of one of the square stone plaques similar to that just described; what remains of the inscription,<sup>1</sup> which is a royal dedication, gives the first syllable Al . . . of what might be the name Al-(zu?) recorded on Eannatum's Stela of the Vultures as that of an otherwise unknown king of Kish i.e., a subordinate ruler who may have held office under the dynasties of Mari or Ak-shak; if the plaque really belonged to him its presence at Ur would imply that he had for a time extended his authority over that city and his ambitions may well have been one of the causes for the campaign undertaken by Eannatum. Of the relief that decorated the plaque not much is left; we have the head and upper part of the body and the left arm of a man who is struggling with a rampant ibex; the subject is one common on cylinder seals and the style of carving is reminiscent of that of the early cylinder-cutter. That this figure with its beak-like face, round eye and straight pig-tail should be as late in date as Lagash is remarkable, yet both the form of the inscription and the possible identification of the donor with a king of Kish contemporary with Eannatum are against its being earlier; it is further proof of the artistic set-back following on the collapse of the First Dynasty of Ur.

The other monument is a sadly battered and incomplete statue in basic diorite (U.2732, Pl. 41) representing a man seated and wearing a fringed skirt that reaches from his waist to his ankles, leaving the upper part of the body bare; the material is poor and the workmanship not good, and to this rather than to its real date may be due a certain resemblance which it bears to such figures as that of Kur-lil of the First Dynasty of Ur found by Hall at al'Ubaid,<sup>2</sup> but the style is in fact less archaic (e.g., in the separation of the arm from the body and in the greater roundness of the modelling) and the script is also later. On the right upper arm is written the man's name, Dada-ilum, together with a priestly title; Legrain comments on this that "the name is Semitic and so too is the prayer SILU (si-lim) and the writing of ZU-EN as SIN; Dada-ilum may be an Akkadian; several DADA diviners are known at the time of Naram-Sin," which would bring our figure down at least to the Lagash if not to the Sargonid period.

The control of Ur by the city of Lagash did not stop with the death of Ur-Nina. From the suburban site called today Diqdiqqeh, about two kilometres NE of the Ziggurat, comes a clay foundation-cone recording a building set up by Enannatum, the fourth governor of the Lagash line.<sup>3</sup> Another clay cone, also found loose from its context, records a foundation by Entemena, his successor, and proves the continuance of the regime; but to his reign a monument of a different sort lends a greater interest. In a gateway in the south-west wall of the Temenos leading into the Ziggurat enclosure of Nabonidus there was found a headless diorite statue of Entemena himself, U.805. The *patesi* stands (Pl. 40) in the usual attitude of prayer with his hands crossed in front of his chest; the upper part of his body is nude and from the waist downwards it is enveloped in the traditional Sumerian *kaunakes*, the shapeless skirt of sheep-skin with the fleece twisted into horizontal rows of tassel-like curls. The body, which stands 0.76m. high, is as usual squat, fat and heavy and the width of the shoulders and the pointed elbows are alike grotesquely exaggerated, but the surface modelling of arms and torso is creditable and the feet are well done; on the purely technical side it shows a mastery over the hard stone which is in marked contrast with the childish efforts of Ur-Nina's craftsmen. On the back and shoulder of the statue is a long inscription<sup>4</sup> which identifies the king but unfortunately tells us nothing about Ur and on the contrary makes it clear that the statue was intended to be set up at Lagash: how or when it was transported to Ur there is no means of saying — whether Entemena sent it thither or whether it was later carried off after a sack of Lagash and set up in Ur as a trophy; but in either case it would seem to have owed its preservation there to its having been regarded, in its headless condition, as a symbol of Ur's release from Lagashite subjection. The mutilation of the figure would be an act of symbolic revenge natural and normal enough, but there is more than that; where the

<sup>1</sup>R.I. No. 14.

<sup>2</sup>Vol. I, Pl. IX.

<sup>3</sup>R.I. No. 2.

<sup>4</sup>R.I. No. 1.

head is broken off the once jagged surface of the hard diorite has been polished to a glassy smoothness, not by rubbing it down with a stone or other tool, for the original inequalities remain, but by the constant touch of something softer than the stone itself: it looks as if the dishonoured monument had stood in a public place where every passer-by flicked the cleft neck with his hand in token of triumph over a fallen master. This can have happened only while the memory of the supremacy of Lagash was fresh in men's minds; that it was found and set up by Nabon-idus in his gateway illustrates the well-known antiquarian tastes of that king. Crude as it is and incomplete, the statue of Entemena has this special interest, that it is the earliest piece of large-scale sculpture in the round that comes to us from the school of Lagash; it bridges the gap between the archaic figures of which a fair number survive and the Gudea series which show the full development of Lagashite art: here the old conventions still hold good, though they have lost the charm of sincerity, but the detail gives promise of better things.

To the period of Entemena must be assigned the group of fifteen graves found in the Royal Cemetery area and published by me as graves of the Second Dynasty of Ur;<sup>1</sup> in them both plano-convex and flat bricks are used, and at Lagash the change from the one type to the other took place during Entemena's reign. They illustrate a partial survival of the old Royal Cemetery and First Dynasty types but much more marked is the connection with the Sargonid age which follows. The fact is that by now the plano-convex brick has ceased to be a criterion of culture; it is itself a survival, and in all other respects the Lagash age, essentially one of transition, looks forward rather than back and its art, at least after the reign of Ur-Nina, anticipates that of the Akkadian dynasty.

There can be no doubt that Ur was subject to the *patesis* and kings of Lagash during the greater part if not the whole of the dynasty founded by Ur-Nina; after the collapse of the last ruler, Urukagina, it passed into the hands of Lugal-zaggisi of Erech and for about twenty-five years enjoyed his special favour—he claims to have uplifted the city's head to heaven "as it were a bull," but of his monuments there nothing has survived: he fell in battle and the sovereignty of the land went to Akkad.

<sup>1</sup>Vol. II, Chapter VII.



CHAPTER V  
THE SARGONID PERIOD

That Sargon of Akkad conquered Ur is known from his inscriptions found elsewhere; at Ur we have a green quartzite mace-head (U.221, *R.I.*, No. 6) which was apparently dedicated by him in celebration of his victory; it was found in the ruins of the temple E-Nun-Mah. Following a precedent perhaps already ancient he installed his daughter En-ĥe-du-an-na as high priestess of the moon god at Ur: in the temple of Nin-gal there was found a white calcite disk – cut in the shape of the moon – on one side of which is a dedication by the royal lady and on the other a carving in relief; it is a scene of sacrifice in which she herself plays the principal part. The stone (U.6612, Pl. 41, *cf. Ur: R.I.*, No. 23) has been smashed and deliberately defaced – the pick-marks are evident, and it is fortunate that one flake on which is the head of En-ĥe-du-an-na was found separate from the stone and almost undamaged; for the rest, nearly all the surface has gone and large fragments are missing altogether. The princess, “priestess of Nannar,” (wife of Nannar) stands with one hand raised watching the sacrifice; she wears a tall mitre and a full sleeved dress of pleated linen which descends in flounces from shoulders to feet; long braids of hair fall over her shoulders and down her back. Behind her a priest, naked from the waist up,<sup>1</sup> waves a fly-whisk over the head of the great lady; in front of her another priest, clean-shaven and wearing a plain skirt reaching to the ground holds up in both hands a tall jug from which he pours a libation into an altar vase; the vase stands at the foot of a stepped monument which is probably the Ziggurat of Ur.

As a historical monument, bringing Ur into direct connection with the northern conqueror and proving how important, even as a subject city, it was in the eyes of the suzerain, this lunar disk is of first-rate importance; as an example of the art of the time it has suffered too severely to be held representative,<sup>2</sup> but even so it helps to illustrate the change in art which the new epoch introduced. The scheme is still stiff and formal, probably because the subject was one whose treatment was limited by religious convention, so that there is here none of the freedom of composition that distinguishes the famous stela of Naram-Sin; but if it be compared with the similar relief U.6831 on Pl. 39, the advance is manifest: there is much more of life and grace in the individual figures and a far truer idea of perspective in the drawing – the awkward mixture of full-face and profile is scarcely noticeable here; above all, instead of the figures being crowded together as in the older work they are isolated against a clear background; it is the same change as has taken place in the seal-cylinders of the Sargonid age and it marks a real departure from the traditions of the Lagash school.<sup>3</sup>

Her own dedication is not the only memorial that we have of En-ĥe-du-an-na's life at Ur; from the cemetery come two cylinder seals, one of Adda, the steward of her household (U.9178), one of another member of her house (U.8988), and an impression on clay from the seal of her scribe<sup>4</sup> (U.11684); as became a daughter of the ruling house she evidently maintained a proper state. The finding of these seals enabled us to date with accuracy the Sargonid cemetery which overlies the Royal Tombs. Much of this was published in the second volume of this series, and a further number of graves excavated in 1933-4 are recorded here in Appendix IV. The new graves have not added much to the general picture afforded by the material from those previously dug and published, but our collection of Sargonid cylinder seals has been increased by 63 examples of which some are the finest yet found at Ur; they are all figured in Vol. X<sup>5</sup> and are referred to here by their serial numbers in that volume.

<sup>1</sup>The prominence of the breasts might make of this figure a young female attendant, but the clean shaven head is in favour of its being a priest; there is not enough left of the original for certainty.

<sup>2</sup>“Its artistic merit, if such it ever had, is utterly marred. But there is, in fact, little to suggest that it showed the mastery of which its period was capable . . . the craftsman . . . was not a very distinguished performer.” Gadd, *History and Monuments of Ur*, p. 93. The stricture seems to me too severe.

<sup>3</sup>The name “Sargonid” is a convenient label, but it must not be assumed that a complete change took place suddenly at the accession of Sargon. As Legrain has pointed out (Vol. II, p. 326) the change is a gradual one and begins before Sargon's time; it can be attributed to the Semitic (Akkadian) element which gradually increased and was already strong before the advent of Sargon gave it definite predominance.

<sup>4</sup>Vol. II, Pl. 212, Nos. 307, 8, 9.

<sup>5</sup>The seals from this Sargonid cemetery published by Legrain in Vol. X are, in his serial numbers, Nos. 44, 62, 63, 88, 92, 95, 103, 105, 111, 129, 130, 131, 135, 139, 143, 156, 157, 160, 165, 166, 172, 176, 178, 179, 181, 182, 183, 186, 187, 188, 200, 228, 231, 237, 238, 239, 242, 244, 281, 288, 291, 292, 293, 294, 295, 296, 297, 298, 304, 305, 307, 327, 328, 336, 353, 354, 507, 550, 552, 561, 633.

As regards the subjects of the seals No. 131 is a last survival of the "banquet scene" characteristic of the Royal Cemetery period; there are still the seated figures drinking through tubes, but the features and costume are those of the Sargonid age. The eagle grasping its prey is also in the old tradition, going back as far as the Jamdat Nasr seal-impressions<sup>1</sup> and the curious stamp-seal No. 103 might itself be older than the Sargonid time. A favourite subject is a combat between man and animals; sometimes the man is evidently a human huntsman, sometimes the long curled beard and formal ringlets must mean that he is a hero taken from the Gilgamesh cycle. Two such seals, Nos. 186 and 187, found in different graves, must surely be the work of the same artist and he a master of his craft, for they are magnificent examples of miniature carving; the rather worn seal No. 188 might also be from his hand though the fineness of the workmanship is less apparent.<sup>2</sup>

The "introduction scene," with the owner of the seal being led by his patron deity into the presence of the greater god is equally common; unknown in the time of the Royal Tombs and rarely found in the later part of the Royal Cemetery period, this was to become the leading motive of the seal-cutter for the rest of Sumerian and Babylonian history. Here at Ur, as was natural, the major deity is generally either Nannar or Ningal, the moon-god or his wife, designated as such by the crescent symbol, but other gods do appear, as Ningizzida the lord of vegetation with his snake and tree (No. 294), and the Semitic sun-god Shamash (No. 237) is to be expected when the Akkadians rule at Ur. Very peculiar is No. 633, a stamp seal, where a god pours a libation before a seated goddess; the cutting is quite unlike that of any other seal and is thoroughly un-Sumerian in character; it looks more as if an Indus craftsman had attempted to deal with a Sumerian subject. This was the age when the civilisations of the Indus and the Euphrates came most closely into contact, and a dozen or more seals found at Ur testify to the commerce between the two countries; in some cases they are obviously imports from India, e.g. those which bear inscriptions in the Indus script, but U.7863 (No. 631) with an inscription in cuneiform must be a local imitation; occasionally (L.BM. 122841)<sup>3</sup> we find stamp seals of Indus form on which both the subject and the style of cutting might perfectly pass for Sumerian, occasionally a seal (e.g. U.16220, No. 632) where subject and style seem to belong to the Indian cycle but the cylindrical form argues for Mesopotamian manufacture. It would appear that there were certain Indian traders resident at Ur to whom the true Indus seals belonged; such might further procure for themselves seals locally cut to suit their own taste, and individual Sumerians might be tempted to indulge in the Indus mode; but the proportion is very small indeed. Upon seal-cutting in general the Indus style exercised no influence at all, and the connection between the two countries denoted by the score of Indus examples known is not necessarily any greater than I have here suggested. It was a trade connection, probably in objects of small bulk, easy to transport, and we have another sign of it in the bleached carnelian beads of which an unusual proportion were found in the new graves of the Sargonid series, and in certain bead-forms (e.g., the metal type 16 of *Ur Excavations*, Vol. II, p. 366, and *Mohenjo-Daro*, Pl. CXLIX, 5 and 7); of the bleached stones the most interesting is U.18862, Pl. 28, which has been bleached white all over and the pattern subsequently etched in black, a double process known also from India. These are not all peculiar to the late period, and parallels from the Royal Cemetery would seem to put the connection further back in time, but that it reached its main development in the Sargonid age seems fully established.

The main interest of the Sargonid seals is that they afford a certain number of illustrations of religious myths and ritual such as are scarcely ever found in earlier times.<sup>4</sup> A few subjects such as Shamash opening the gates of the morning (Nos. 238, 239) are easily recognised, and the seal of Ur-mah-dim, No. 244, may represent the victory of Ninurta over Zu the storm-bird with Ea standing by, but a scene such as that of Nos. 227, 228, 231 with its winged shrine borne by a bull and approached apparently by a ladder is difficult to interpret, as is the splendid picture of a god in a chariot drawn by a winged dragon, No. 92.

Of buildings of Sargon's time we have found no trace whatsoever; only in Pit X does a single brick-lined grave give the measurements of the bricks locally used at the time;<sup>5</sup> they measure 0.25m. x 0.18m. or 0.15m. x 0.09m; for a knowledge of Sargonid palaces and private houses the historian must turn to the excavations at Tell Asmar.<sup>6</sup>

Ur rebelled against Akkad, probably in the general rising that overshadowed the close of Sargon's reign; at any rate it was conquered afresh by Sargon's son Rimush and had to suffer the destruction of its

<sup>1</sup>Vol. III, Pls. 2, 16, 17.

<sup>2</sup>The fact that the seals were in separate graves should mean that they were of local manufacture; that gem-cutting was practiced at Ur at any rate in the following period we know from finding "trial-pieces," sketches on chips of limestone or on pottery.

<sup>3</sup>For seals of this sort not figured in Vol. X see Vol. II (U.11181, Pl. 192; U.17649, Pl. 211; U.11958, Pl. 215); These are all assembled by Gadd, "Seals of Ancient Indian Style Found at Ur" in *Proceedings of the British Academy*, Vol. XVIII, October 1932.

<sup>4</sup>H. Frankfort, "Gods and Myths on Sargonid Seals," in *Iraq*, Vol. I, i, p. 2 ff.

<sup>5</sup>In the Tell Asmar buildings dating immediately after the plano-convex period the flat bricks measure c. 0.30m. x 0.20m. x 0.05-7m.

<sup>6</sup>*The Oriental Institute of the University of Chicago, Communications*, Nos. 13 and 16.

walls. But the new king seems to have borne little malice, for he enriched the temples of Ur with many of the spoils taken from his sack of the cities of Elam, and in the ruins of the temples at Ur there have been found fragments of a number of the vessels so dedicated. The fine calcite mace-head U.206, (*R. I.* 10, Pl. D), is one of them, and of stone vases we have four or five examples; most of these bear simply the inscription, e.g., *R. I.* 8, and 22, but U.231, Pl. 36 (*R. I.* 9), of which unfortunately only three fragments remain, was a bowl of black steatite decorated with reliefs of a most unusual type; apparently there was represented a two-headed demon attacked by an ibex and a dog, while another figure was engaged with a long-necked monster; the technique of the work, which is virtually in two planes with no rounded modeling, is peculiar, and the treatment of animal forms is by no means in the Sumerian tradition; remembering that, according to the inscription which it bears, the vase was part of the spoil brought back from Susa we should perhaps be wiser in regarding it as an example of Elamite work rather than as illustrating a new departure in the art of Sumer.

A minute fragment of another steatite vase on which was a battle-scene (U.7072, Pl. 36) is also of this period, and so, undoubtedly, is the extremely fine fragment of a steatite vase U.224 on Pl. 35; it represents the water-god Ea holding two vases out of which flow streams of water (the figure was repeated so as to form a frieze round the bowl); it is interesting to compare this with the finest of the cylinder seals of the Sargonid age; the figure itself is remarkably like those on the seals and the way in which it is detached from the plain field is an exact parallel to what has been observed in them as characteristic of Sargonid art.

Manishtusu, the next Akkadian ruler, is represented indirectly by a copy made on clay by a scribe or student of the Larsa period of the inscription from the base of a statue set up by Manishtusu at Ur and dedicated to Enlil. Similar copies<sup>1</sup> of ancient inscriptions shew that statues were erected by Naram-Sin also after his victories over Elam and Subartu, but of this king we have a more immediate memorial in the form of a granite bowl, U.6355,<sup>2</sup> which bears his inscription; it must have been treasured in the palace of the city's governor, for nearly three hundred years later it was dedicated to Ningal (it was found in the ruins of her temple the Gig-par-ku) with a fresh inscription added by Me-Enlil the daughter of king Dungi of the Third Dynasty of Ur; probably she held the post of priestess of Nannar traditional in the royal house. Two votive mace-heads, U.284 and U.16531, witness to the piety shewn by Naram-Sin to the temples of Ur.

For four generations Ur had been subject to Akkad. When the dynasty of Sargon, in the fifth generation, was broken up by the invasion of Gutu and there ensued that period of chaos which made the chronicler insert in his king-list the despairing query "Who was king, who was not king?" the city seems to have made no effort to gain its freedom; under the loose Gutu rule various local dynasts secured virtual independence, but Ur gravitated once more to an old allegiance. Fragments of no less than five inscribed calcite vases (*R. I.* 25) have been found dedicated by En-anni-padda the son of Ur-Bau the *patesi* of Lagash who founded what was to prove a long-lived dynasty of rulers not indeed claiming the title of king but exercising undisturbed by the Gutu a royal control over a wide district and even on one occasion embarking on an Elamite war. En-anni-padda describes himself as priest of Nannar, and the title he uses is the same as that given to Sargon's daughter; evidently Ur-Bau when he added Ur to his dominions followed the tradition whereby the high-priesthood at Ur was a prerogative of the reigning house, though in this case he appointed a son instead of a daughter. Incidentally Ur-Bau was succeeded on the throne by two sons-in-law, so presumably En-anni-padda either died before his father or preferred the peace and emoluments of his priesthood to the risks of secular power.

That Ur remained subject to Lagash during the next five reigns is probable but no monuments have been found to prove it: but from the time that the energetic builder Gudea inherited the governorship of Lagash there is no lack of evidence to shew that his control of Ur was secure and his interest in the city active. No buildings of his have been unearthed, probably they were swept away to make room for the new constructions of the Third Dynasty of Ur, which would be patriotically impatient of monuments recalling the old days of servitude, but the scattered foundation-inscriptions shew that at least two temples, dedicated to Tammuz and to Nin-dar, were originated by him.<sup>3</sup> The building of temples implies the presence in them of cult statues and votive statues of the benefactor: the age of Gudea is remarkable for its sculpture in hard stone, illustrated by the long series of portrait figures of Gudea discovered at Lagash in part by the French excavators and in part by illicit plunderers of the site. We have found at Ur many fragments of diorite sculpture, life-size figures of the Gudea type, but in every case they have been deliberately hacked to pieces. The three best pieces are shewn on Pl. 42, U.1658 and 18299 and 114198, found by Dr. Hall. It is impossible to date such fragments exactly; realising the political importance and wealth of the Third Dynasty, which directly succeeded the Gudea period, it is tempting to assign to it these wrecks of splendid

<sup>1</sup>Ur: *R. I.*, Nos. 274, 275.

<sup>2</sup>Ur: *R. I.*, No. 24, Pl. E.

<sup>3</sup>*R. I.*, Nos. 27, 28.

sculpture, especially as it is precisely in the field of sculpture that the Third Dynasty is most poorly represented: but the style is definitely in favour of their belonging to the Gudea school. In U.18299 the fashion of the turban and the feather treatment of the eye-brow are identical with what we find on the Gudea statues; of U.1658 it can only be objected that the modelling is perhaps too delicate for the Lagash artists; on the whole it is safest and sanest to group these fragments with the known examples which they do so closely resemble rather than from them to build up a school of Ur sculpture. With their Lagash origin the wanton destruction of the statues would thoroughly accord.

Of certain other pieces of stone sculpture we cannot speak so confidently; they may belong to this period or they may have been made in a later age which was faithful to its teaching: but just because the doubt exists there is advantage in bringing them together with those which can safely be attributed to the Gudea time so that there can be comparison.

The diorite head of a woman, U.6444 on Pl. 43, is in its combination of strength and delicacy a most unusual piece of Sumerian art; like the marble head U.6782 on the same plate, it shews the sculptor not contenting himself with conventional types or semi-realistic portraiture but consciously seeking after an idea of beauty; there is in these heads more of the Greek spirit than Eastern art was ever again to exhibit. The inlaid eyes of the marble head are in the old Sumerian tradition, the carved eyes of the diorite head betray the influence of the Lagashite school, but in both cases the artists have risen above their masters and have created something which was new to their world. It is natural to judge the sculpture of this age by the criterion of the Gudea statues, simply because they are almost the only examples of it that we possess; but it must be remembered that in the past the Lagashite school had lagged very far in the rear, and although under Gudea splendid works of portrait sculpture were produced by it, it is quite conceivable that in accepting them as the best of which the age was capable we may be doing an injustice to the artists of other and more important cities. To assert, on the strength of two damaged heads of none too certain date, that in the Lagash period Ur rivalled or surpassed the sculptures of Gudea's capital would be going beyond the evidence; but that the city should have been without its artists is incredible and at least we have here two works which had they been found at Lagash would have surprised us by their quality.

On Plate 42 are collected other fragments of statues of less interest and also of doubtful date. The clean-shaven priest U.6417 with inlaid eyes and eye-brows is altogether in the old tradition but shews a softness of modelling in cheeks and mouth which might justify its attribution to this period. The small head U.7144 is strikingly individual, a portrait in which the likeness is apparent and involves, especially in the treatment of the lips, a complete departure from the accepted canons; it may well belong to a rather later date. The others, one rough and perhaps unfinished, the other battered beyond recognition, do not call for comment, except that in U.6578 the roll of fat at the back of the neck is an interesting touch of realism.

To the Lagash period, or to the Third Dynasty which followed it, can be assigned the sculptured limestone bowl U.232 on Pl. 36. It is fragmentary and the surface of the stone is much worn, so that of its artistic merit there is little to be said; the subject, worshippers appearing before seated gods, is a commonplace of the seal-cutter and is here merely repeated on a larger scale: it was found in the ruins of E-Nun-Mah, the joint temple of Nannar and Ningal, and the two deities represented are presumably those of the temple. Typical also of the decoration of the period is the frieze of vases from which flow streams of water on the fragments of another limestone vase U.449 on Pl. 36. U.239 on Pl. 35, is a fragment of a magnificent steatite bowl from the E-Nun-Mah treasury; it preserves part of an inscription from the style of which it can be judged to belong either to the Gudea or to the Third Dynasty age, and it can therefore appropriately be described here. The bowl is surrounded by (originally four) figures of recumbent oxen whose bodies, seen in profile, are carved in relief and their heads, turned outwards over the right shoulder, project in the round; this is altogether in the Jamdat Nasr tradition as exemplified by the bowl U.18118 on the same plate, but there is here a softer style and a more realistic treatment that belong to a later time. Both the figures of the animals and the background were enriched with shell inlay;<sup>1</sup> on the background above the animals' backs are the sun, the crescent moon, stars and a large rosette, on the forehead of the bull is a crescent moon and dots and trefoils bestrew his body and in the field in front of one are large double crosses. The astronomical character of the piece is obvious; apart from sun and moon, the dots on the chest and leg of the bull recall, perhaps intentionally, the stars of the Great Wain; the seven trefoils, resembling those on the Hathor cow of Egypt, may stand for the seven major planets. This is "the great Bull of Heaven," the moon-god Nannar under whose protection the city of Ur flourished, and the bowl is a fitting vessel for his temple.

Of Ur-Ningirsu, who succeeded Gudea as *patesi* of Lagash, we have a brick-inscription that records his building of a temple to Ningirsu his patron god;<sup>2</sup> Ur therefore remained subject to the neigh-

<sup>1</sup>Of that seen in the photograph some is original, some had fallen out and has been replaced with white wax.

<sup>2</sup>*R. I.*, No. 282.

bouring city. Soon after this Utu-ḫegal of Erech by one decisive battle put an end to the shadowy tyranny of the Gutti kings and made himself master of Sumer and Akkad. It would seem that as governor of Ur he installed one Ur-Nammu. Ur-Nammu appears, from an inscription found at Lagash, to have attempted encroachments on the territory of that city and to have been called to order by his overlord. At Ur two inscriptions have been found, dedications to Nannar and to Ningal respectively,<sup>1</sup> one, decorated with the flaming sun and the moon's disk, in which the governor Ur- . . . (the rest of the name is missing) makes his prayer for the life of Utu-ḫegal the mighty man, king of Erech, king of the four quarters of the earth. They were idle professions. Seven years after the victory over the Gutti which established the dynasty of Erech Ur-Nammu rose in rebellion and defeated his master; in the second inscription he claims the title of king for himself. A new epoch opens with Ur as the capital of a Sumerian empire.

<sup>1</sup>R. I., Nos. 30, 31.

## APPENDIX I

## DETAILED DESCRIPTION OF THE EXCAVATED SITES

## Pit A (Plates 1 and 72)

The shaft started at level 6.70 m. above sea level and the ordinary stratified rubbish of the cemetery area continued for 0.90 m. to what seemed to be a definite surface level, a thin layer of ashes and pottery.

From 5.80 m. to 4.90 m. was clean soil. Between 4.90 m. and 4.70 m. was a darker band mostly of rather gritty dark soil but in one place of burnt ash; in it was a large store-jar, its rim flush with the top of the dark band, its base sunk below it; probably therefore the band marks a (short-lived) surface level.

From 4.70 m. to 2.20 m. was absolutely clean water-laid sandy clay.

From 2.20 m. to 2.10 m. was an occupation level containing quantities of flint chips and cores and fragments of al 'Ubaid pottery.

From 2.10 m. to 1.40 m. was dirty mixed soil (not water-laid) containing numerous potsherds, all of al 'Ubaid types, lumps of red burnt clay (such as in Pit F were found resulting from the destruction by fire of reed-and-daub buildings) and some fragments of burnt bricks, of different sizes, so far as could be judged, and one complete brick; it measured 0.20 m. x 0.12 m. x 0.065 m., the top of it was irregular but not domed (it was not a plano-convex brick) and the corners were rounded; it was found together with lumps of bitumen.

The excavation of the shaft stopped at 1.40 m. above sea level.

## Pit B (Plates 1 and 72)

The shaft started at the floor level of grave PG/1237, 8.40 m. above sea level; it was little more than a metre square.

Down to level 6.90 m. there was the ordinary rubbish of the graveyard; of this the upper 0.80 m. was tolerably clean and the rest stratified rubbish of the normal sort. From 6.90 m. to 3.20 m. there was clean sandy clay, water-laid; half-way down in it was a piece of fossilised bone, but nothing else. The bottom of this was not level, varying from 3.20 m. to 3.05 m., and at the very bottom there were collected a few potsherds; but owing to the irregularity of the bottom it was difficult to be sure whether these sherds really belonged to the stratum in question or to that immediately below it.

From 3.20 m. to 2.00 m. was ashes and rubbish containing a great quantity of pottery; all of this was of the al 'Ubaid type, some painted, the rest plain and most of it of the characteristic greenish coloured clay; with it were two fragments of pottery beads of the long cylindrical type with spiral incisions imitating the beads made from the central column of the conch shell.

From 2.00 m. to 1.90 m. there was sandy soil with a small admixture of potsherds.

From 1.90 m. to 0.90 m., the lowest point to which the shaft was sunk, there was clean sandy soil which had every appearance of being virgin soil.

## Pit C (Plates 1 and 72)

The normal formation of the rubbish-mounds disturbed by the graves went down to 6.55 m. above sea level. Below the lowest grave there came forty centimetres of mixed soil with a moderate amount of pottery, then for fifty centimetres alternating thin strata of grey, dark grey and brown, all very clean, looking like the result of a very slow deposit. From 5.65 m. to 5.20 m., uniform light brown clayey soil, not very stiff, clean and practically free of pottery.

5.20 m. to 5.10 m. a yellow band fading off to a black surface; in it are potsherds lying horizon-

tally, all just under the black surface.

5.10 m. to 4.95 m. a similar stratum, the black surface less clearly defined.

4.95 m. to 4.85 m. a similar stratum.

4.85 m. to 4.80 m. a similar stratum.

4.80 m. to 4.70 m. grey muddy soil looking like a surface with broken pottery lying in it.

4.70 m. to 3.65 m. a uniform bed of clean sandy yellow clay, water-laid. In the lower part there is no pottery at all, in the upper part very little.

3.65 m. to 3.05 m. a regular alternation of black or grey ash with yellowish clay strata, all water-laid and from the fineness of the strata appearing to be a deposit very slowly formed. Pottery very scarce indeed. From 3.65 m. to 3.55 m. there is a particularly marked black band with a streak of white down the middle.

3.05 m. to 2.90 m. black and grey ash alternating in very fine strata.

2.90 m. to 2.65 m. a very definite break. Hard clay containing lumps of brick clay burnt red (not bricks); the clay very clean below but above getting more mixed with black rubbish.

2.65 m. to 2.30 m. black rubbish, burnt or carbonised stuff mixed with mud; it was broken by two thin irregular strata of burnt earth and grey ash which did not present any clear horizontal line.

2.30 m. to 2.15 m. a stratum almost entirely composed of potsherds in light rubbishy soil, with some bone fragments; the potsherds all apparently made on the slow wheel.

2.15 m. to 1.70 m. stiff damp water-laid mud, gritty and full of sand, containing a fair proportion of potsherds; the stratum as a whole is black but has a narrow band of stiff yellow clay at its top.

1.70 m. to 1.55 m. a similar stratum but with few potsherds and of a lighter colour, the mud being dark grey and black only at the top; it is of the type found on the bank of a stream rather than in its bed (unless the stream be extremely sluggish).

Work ceased at this point, 1.55 m. above sea level.

#### Pit D (Plates 1 and 72)

A shaft was sunk close to the side of the grave-shaft of PG/1332 where the rubbish stratification of the cemetery area was particularly clear, beginning at about 8.90 m. above sea level, a band of brick clay with occasional potsherds.

8.60 m. to 8.30 m. a band of pale grey ash and light yellow sand above which and partly mixed with it are numerous potsherds and some lumps of green clay.

8.30 m. to 8.05 m. brick clay with a little pottery.

8.05 m. to 8.00 m. a thin layer of light grey ash.

8.00 m. to 7.60 m. a mixture of brick clay and burnt ash with very little pottery; below it a thin streak of grey ash. In this stratum occurred an example of the pottery form JN. 139 and a large urn containing animal's bones, the teeth of a sheep or goat, a clay tumbler of type JN. 21 and a pebble rubbing-stone; at the same level were fragments of a basic diorite and of a limestone bowl apparently of type JN. 20.

7.60 m. to 7.30 m. a stratum of burnt black material, like soot but firmer; it was not uniform, much of it being clean, but there were patches which contained quantities of potsherds; it looked as if the potsherds had been thrown in in basketfuls and the ashes had filled up the hollows between and had covered them. Mostly in this stratum but also in the thin layer above and in the upper part of the stratum immediately below there were found inscribed clay tablets of archaic type (*Ur Texts*, Vol. II, Nos. 305-7) and many seal-impressions on clay (*Ur Excavations*, Vol. III, esp. Nos. 167, 186, 216, 227, 242, 255, 256, 280, 286, 291, 293, 302, 307, 328, 337, 368, 387, 417, 426), these being of the regular SIS IV-V type.

The stratum was irregular and soon tailed away; 10.00 m. to the NE it could scarcely be distinguished; it seems to be the artificial filling of a hollow place in the rubbish mounds. Where it ends the deposit of tablets ends also.

7.30 m. to 6.40 m. very clean soil. At 6.40 m. a very definite line of broken pottery. Below this clean clayey soil and a second marked layer of broken pottery at 5.80 m. Again a stratum of clean clay and a layer of potsherds, sloping from NW to SE, at 4.90 m. Below this to 3.90 m., the limit reached by the excavation, was blackish clayey mud with very few potsherds.

#### Pit E (Plates 1 and 72)

Close to the royal grave PG/777 a shaft was sunk against the face of the wall of the second pre-cemetery series of buildings, starting therefore at level 9.00 m. It was carried down to 2.35 m. above sea level.

Mixed soil lying against the wall face went down to 6.65 m. in fine strata running at a slope; below this was unstratified rubbish going below the wall foundations (at 6.45 m.) to 6.25 m. From this level to 4.85 m. was clean and hard mud brick soil packing. From 4.85 m. to 4.35 m. was a band of rubbish with plentiful potsherds, broken brick etc. From 4.35 m. to 3.35 m. was fairly clean clay. From 3.35 m. to 2.35 m. was black muddy soil full of ashes and with quantities of potsherds, the top of it looking like a natural surface.

#### Pit F (Plates 1, 73-75)

The area excavated lies NE of the building site EH (Pl. 71) but by the denudation of the original hill the ground surface had been reduced to no more than 18.00 m. above sea level, about one metre below the level of the plano-convex brick floors found on the building site. Since this difference of altitude is due entirely to denudation and the stratification of the building site EH extended, as we have every reason to believe, uniformly over the site of Pit F, we have to assume the disappearance of at least one and probably of two strata of plano-convex brick building which once overlay the highest building actually found by us in the pit excavation. This conclusion was derived from the character of the terrain and the archaeological data derived from the EH excavation: it was fully borne out by evidence in the pit itself.

BUILDING STRATUM A. 18.00 m. above sea level.

Walls were found immediately below the surface and went down to about 16.50 m.; one building occupied the whole of the SE end of the pit, another lay in the approach to the pit dug by us in its north corner; the foundations of the latter were rather deeper than those of the first building but shewed no true floor levels. In the NW part of the pit there was an open space with only scanty remains of a wall, 0.60 m. thick, once heavily plastered with bitumen; it was constructed of unshaped lumps of clay set in mud mortar. The main building at the SE end of the pit contained no mud bricks at all; all the walls were of large shapeless lumps (basketfuls?) of hard clay set in mud mortar; in the case of the buttressed NW wall the construction was particularly clear; a trench had been dug and a strip of coarse matting laid along the bottom of it, and over this the clay lumps (average measurement 0.30 m. x 0.30 m. x 0.20 m.) had been laid, with the stiff mud mortar; the outer face of the wall was plastered thickly with mud. Differences in the foundation-depth of different walls seemed to indicate rebuilding or repairs at different periods. Room 2; the SW wall went down for 1.10 m., floor level was at 0.90 m., but the cross-wall between rooms 2 and 3 was 0.40 m. above that floor level; floor in rooms 3, 5, and 6 was the same as in room 2; the cross-wall between rooms 2-3 and rooms 5-6 was shallow and therefore late compared with the outer buttressed wall, whose foundations were 1.10 m. below the surface; the other cross-walls seemed to be early. Below this late wall was a box made of burnt bricks measuring 0.31 m. x 0.21 m. x 0.05 m., slightly plano-convex; two layers of matting and two layers of mud alternating with layers of black wood ash lay above it; inside was earth, lime and decayed white vegetable matter resembling chopped straw; it was presumably a foundation-deposit. Under the (late) cross-wall between rooms 2 and 3 was a plain clay tumbler of Type RC. 7a.

In Square C4 was a rubbish-pit dug down into the room from a higher level (later therefore than the building) and ending at a depth of 1.80 m. below the modern surface. It contained a large but badly smashed offering-table of drab clay with incised decoration, U.13709, Fig. 8,g, a clay vase, of Type RC.16 and one of Type RC. 126, a clay tumbler RC. 7a and a cup RC. 5b, from which it results that the rubbish-pit was not later in date than the First Dynasty of Ur. In Sq. C5 the drain in the corner of room 2 was also later than the building, for its bee-hive-shaped top was complete and stood 0.60 m. above floor level (Pl. 45,j). The drain in room 3 was much destroyed, only the lowest rings remaining, and these did not go down as low as floor level; inside at its base were quantities of pottery fragments including some of the tumbler Type RC. 7a, a First Dynasty type, and of Type RC. 53, together with a rubbing-stone and whetstone, a fragment of a white calcite bowl, a flat oval stone palette, an obsidian chip, half of a spindle-whorl of polished pink stone (U.13704) and a circular clay loom-weight. In Square D4 the drain was definitely as late as the Third Dynasty of Ur; only the base of it survived, dated by clay pots of Type RC. 26; close to it was a pot of Type RC. 130. Square D5; at a depth of 1.25 m. from the modern surface, i.e., 0.35 m. below the floor, but possibly connected with it as a foundation-deposit, was a box of burnt bricks measuring 0.30-31 m. x 0.19 m. x 0.04-5 m., which were really flat and not plano-convex at all; inside the box was a mass of light ash with what looked like calcined grain and one small fragment of an animal bone. In Square E4, 0.20 m. below the surface, were the remains of a circular basket 0.50 m. in diameter and 0.25 m. deep; by it was a fragment of an archaic tablet (U.13658) resembling those from SIS 4-5, two lapis lazuli beads, a barrel and a double conoid, and a copper pin of Type 7; it looked as if all might have been lying on one floor level of which little trace was left. At 0.20 m. lower down, near the drains, were numerous lumps of oxide of iron, shapeless and perhaps not metallic, together with lumps of cuprous oxide; they extended over a considerable area.



Square E 5; of the drains cut through the stratum here, (a) went down to a depth between 2.00 m. and 3.00 m. below the modern surface; it contained potsherds of Type RC. 7a, dating it as not later than the First Dynasty of Ur, and a drain-pipe 0.77 m. long and 0.20 m. in diameter with a collar at one end (U.14488). By the side of drain (c), dug through the room wall, 0.20 m. above the floor, was the white shell cylinder seal U.13726. The pottery round the drain was more like that of the Third than of the First Dynasty, but there were no types giving conclusive evidence.

The fact that the building is pierced by drains of later date some of which are themselves as early as the First Dynasty of Ur and must, judging by the small amount of them that remains, have served buildings lying at a considerably higher level, means that the building of Stratum A comes well back in the "plano-convex brick period." In the NW part of the pit, lacking walls and floors, the stratification is less satisfactory.

Square C 7. In the rubbish-pit was a single mud brick, slightly plano-convex, 0.23 m. x 0.17 m. x 0.085 m.; being where it was it had no dating value. At the bottom of the pit (0.90 m. below the modern surface) there were fragments of burnt bricks incomplete but of Third Dynasty form; the pottery fragments were not distinctive. This was a re-use of the pit; below the apparent bottom it continued down through two more building strata to a depth of 4.20 m. Square C 8; the drain goes on down to 3.00 m. below the modern surface; at the bottom of it were clay cups and tumblers of Types RC. 5b and RC. 7a.

Square D 7. The two drains, (a) and (b), of which only the lowest rings remained, emptied into irregularly shaped holes full of light rubbish and ashes amongst which were examples of clay Types RC. 7a and RC. 16; the pit was therefore First Dynasty, the drains later. A circular rubbish-pit near the surface contained the clay Types RC. 26 and 76 and fragments of tablets (U.13615-21, 13624-9) of which four (U.13615-8) bore inscriptions of Dungi.

Square D 8. Drain (a) consisted of 4 rings going down for 2.00 m.; at the bottom of it six clay tumblers, Type RC. 7a, fragments of cups Type RC. 5b, and libation-vase Type RC. 16. Drain (b) went down to a depth of 3.70 m.; it contained fragments of plano-convex burnt bricks, a clay tumbler Type RC. 7a, pots of Types RC. 45 and 53, two lapis lazuli bugle beads and some small animal bones. Drain (c), made of ribbed rings, ended in this stratum; in the packing round it were fragments of clay Types RC. 5b, 9, 16, 26, 66 and 108b, one with small lugs on the shoulder, Fig. 8, a, one with combed ornament, U.13708, Fig. 8, b.

Square E 7. Drain (a) was definitely late, the packing round it including examples of clay Type RC. 26 (Sargonid-Larsa) as well as of Type RC. 4; a clay tablet U.13648 was found here. Drain (b) was reduced to a single ring. Drain (c) had two rings left; it seemed to have been destroyed when drain (b) was made; by it was a clay pot Type RC. 51a. At about 0.50 m. below the modern surface there were found loose in the soil a libation-vase Type RC. 16, vase Type RC. 46, a fragment of a handled bread-pan, cf. Fig. 8, d, a copper tool U.13701, Pl. 30, and a grey stone whetstone, octagonal section, l. 0.115 m., U.13702; these should be contemporary with the stratum.

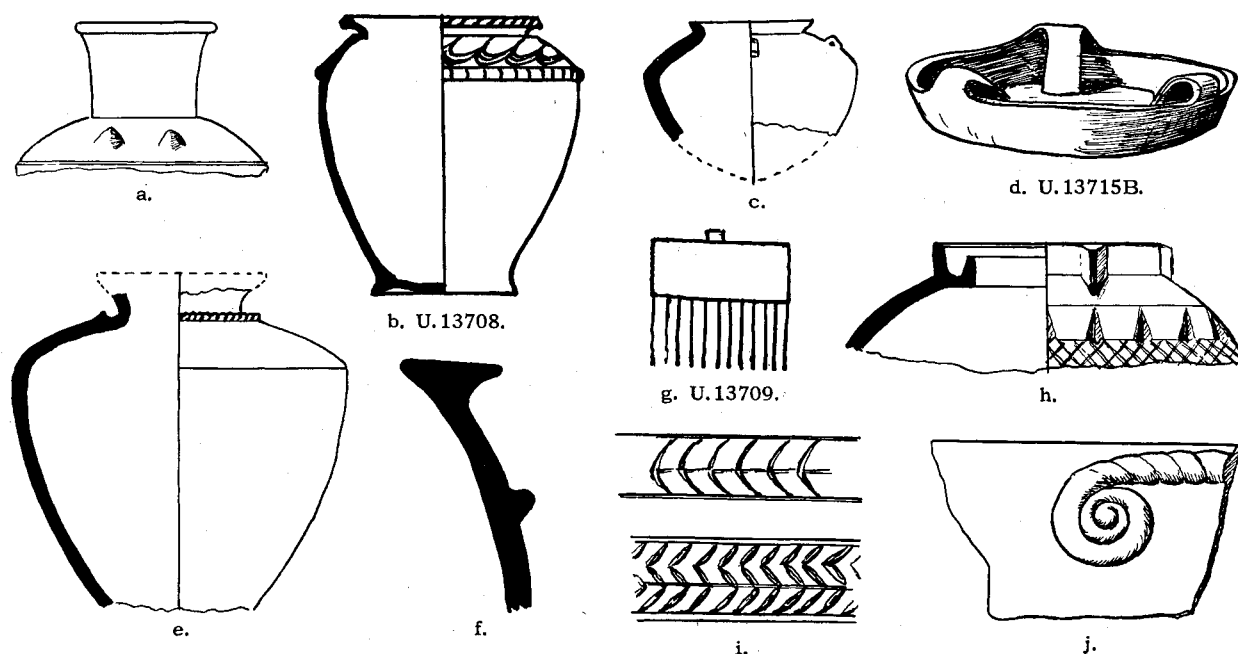

Fig. 8.

Square E8; at 0.40 m. below the surface, beneath a patch of clean clay which might be the remains either of floor or wall, was a square of matting on which stood inverted a clay cup; beside the cup as if spilt from it were small fragments of animal or bird bones; it was probably the foundation-deposit of a building now altogether destroyed. Near this was a shell cylinder seal U.13703, also a pair of cockle-shells and a fragment of a white limestone spouted bowl Type RC. 102. Square F7; both the drains contained unbroken examples of the clay cup Type RC. 5b, and one of them a (broken) clay model boat. Square F8; just below the modern surface were 3 boxes made of burnt plano-convex bricks set on edge, measuring 0.31 m. x 0.20 m. x 0.045 m. increasing in the centre to 0.06 m.; these must belong to a building now denuded away. Below the boxes were found an upper and lower grindstone of lava, a lump of bitumen apparently the setting for a quern, a flint core, U.13706, fragments of a white calcite bowl Type RC. 19d and two disks cut from potsherds. A rubbish-pit (or bottom of a drain-shaft) contained burnt bricks of Bur-Sin and Ibi-Sin and some of Larsa date.

BUILDING STRATUM B. 16.40 m. above sea level.

The buildings, the foundations of whose walls went down 0.50 m. below floor level, were a reconstruction on a modified plan of an earlier structure and though the outer wall had been remodelled and did not follow the original line the NE x SW cross-wall was based on the old and seemed to be part of a reconstruction of that old building incorporated in the new rather than a part of the new work. It was built of plano-convex mud bricks measuring 0.20 m. x 0.15 m. x 0.05 m. increasing to only about 0.06 m. in the centre, of a markedly green clay, set in yellow clay mortar as headers, slantwise and on edge, herring-bone fashion:<sup>1</sup> the enormously heavy outer wall of the building was also of plano-convex mud bricks, but they seemed all to have been laid horizontally.

The small room 1 (Square C4) had at 1.45 m. from the modern surface a good mud floor covered all over with matting; 0.15 m. below this was a second floor of clean clay. In room 3 (Square D4), there lay on the floor a large clay jar, U.13736, Pl. 45, and below the floor were numerous clay sling-bolts; at about floor level was a shell cylinder seal U.13711, (Vol. X, No.55), a fragment of a clay handle decorated with rings of purplish-brown paint, and a fragment of a vase ornamented with clay *appliqué*. The two rooms 2 and 4 (Squares C and D5), were filled with a stratification of a curious sort; alternating layers of clean yellowish clay and of sooty grey, sometimes separated by minute streaks of black, all so thin that in a vertical height of 0.75 m. (Pl. 2,a) 65 layers were distinguishable; only one layer contained any rubbish at all, all the rest were very clean and all seemed to be water-laid; they lay horizontally except that against one wall the strata curved up slightly to its face. I imagine that the layers are composed of wind-blown dust and of clay washed down by rain from the house walls respectively; they must represent a period of desertion of the site, but it would be unsafe to argue that the period was necessarily very long; allowing for a greater rainfall in antiquity the flooding of the rooms which the strata certainly denote may have followed in fairly quick succession, and a few years might produce the results here observed. Below the strata in D5 was found a pebble bead U.13727, a thick ring resembling those found in the graves of Jamdat Nasr and rather later date. In Squares E4, 5, 6, there were numerous ring-drains all more or less contemporary with the building; the most interesting was that in E6 (Pl. 2,b); from the room a slender drain-pipe set at a slight angle and fitted into a larger pipe (a smaller flared pipe lay above this but had no apparent connection with it) ran through the thickness of the wall and emptied into a vertical drain made of the normal clay rings which went down to level 13.50 m. so as to dispose of its contents in the subsoil. Inside this main pipe was found a clay pot, Fig. 8,c, having pierced lugs on its flat shoulder and covered with a poor and thin wash of rather powdery red paint; it is a type which occurs as early as the Jamdat Nasr period and continued in use for some time afterwards.

The NW end of the pit was, at this level, an open space; there was no proper floor except at a depth of 1.75 m. from the surface, i.e., 0.30 m. below the level of the room floors and so not necessarily of the same date. In Square C7, above this floor level, was a single loose brick, a burnt plano-convex brick not markedly convex and having a long groove in its upper face, measurements 0.27 m. x 0.13 m. (increased at one end to 0.15 m.) x 0.03 m. at the edges and 0.05 m. in the centre. A cup of blackish-grey clay resembling Type RC. 7d but squatter in its proportions (ht. 0.075 m., diam. 0.09 m.), v. Type JN.162, was found in Square C6 not in any rubbish-pit but in its true horizon. In Square C8 there was on the floor a rough enclosure (a hearth) of broken burnt bricks of the flattened plano-convex type 0.28-9 m. x 0.19 m. x 0.04 m. and one with a single finger-hole in the top 0.32 m. x 0.19 m. x 0.04 m.; by them was a clay libation-vase Type RC. 16, broken in antiquity and mended with bitumen. Two clay cups of Type RC. 5b found together on the edge of our pit were in a rubbish-pit; loose in the soil were 3 flakes of obsidian, at floor level, and a fragment of a disk of white obsidian ground down to a thinness of a millimetre (U.13716). In the corner of Square D6 were fragments of a very large libation-vase Type RC. 16 and by it the base of a clay pot, diam. 0.35 m.,

<sup>1</sup>Very similar green clay bricks in yellowish mortar were used in a wall in the Great Cemetery area, a building of pre-cemetery date, one corner of which had been cut away by the shaft of the royal tomb PG/777.

with a crinkled ribbon band round the shoulder, Type RC. 88b. In Square E7 there was a hearth-bowl sunk in the floor (level 15.90 m.); the drain here is apparently contemporary with the building as it starts at floor level. Below the bases of the drains coming down from the upper levels was an example of the curious clay bread-pan Fig. 8,d, U.13715 B. A second example was found in Square E8 (U.13715 A) and by it part of a very large drain-pipe 0.20 m. in diameter with trumpet mouth, part of a decorated bowl in basic diorite (U.13717, Pl. 44), examples of clay Types RC.16 and RC.120 (the former occurred several times in Square E7) and, in the bottom of a rubbish-pit, examples of clay Types RC. 5b, 7a, 16, and with these a quantity of fish scales and the bones of animals. In Square F8 was part of the base of a large white calcite vase of Type RC. 4; part of the handle of a clay sickle and a fragment of a wall-cone found 0.40 m. below this were out of their true horizon.

Four tablets were found in this stratum and must be connected with the building or be later than it. In Square E4 were U.13654 and 13658, in Square E7, U.13844, all three at level 15.90 m., and in Square E6 U.13683, at level 15.20 m. All are account tablets, of archaic type (pre-Sargonid) but not so early as those from the SIS 4-5 collection.

#### BUILDING STRATUM C. 15.00 m. above sea level.

The floors were on the 15.00 m. line, the foundations of the walls going some fifteen centimetres lower. In spite of their great solidity the remains were not easy to understand, being confused by re-building. The original plan gives us little more than two very heavy buttressed walls running almost parallel and joined by a cross-wall; of these two the SE wall in the later period and probably in the earlier also acted as retaining-wall to a terrace and its internal buildings were on a higher level than those to the NW. At a later period both walls were restored and strengthened by a revetment or *kisu* added to their outer (NW) faces, obliterating the buttresses of the old work. In the case of the SE wall, the original buttress had a battered face, the face of the main wall stretch was vertical, the bricks were unbaked, plano-convex, measuring 0.20-0.21 m. x 0.11 m. x 0.05 m. at the edges rising to 0.075 m. in the centre, of light yellow clay set in grey mud mortar; the back face of the wall was rough: the new *kisu* was applied only to the main stretch of wall, the buttress being left untouched; the *kisu* was of plano-convex mud bricks 0.25 m. x 0.17 m. x 0.09 m. of grey colour set in yellow mortar. The NW wall was not so solidly constructed and both wall-face and buttress-face were vertical, not battered, but there was a 0.15 m. wide footing against the base just above floor level; the *kisu* covered the main wall, the buttress-face was brought level with the new work by the addition of a thick mud plaster, but as the buttress had been ruined down to a height of 0.90 m. the new brickwork was carried over the top of it and of the mud plaster. The wall further to the SE, cross-hatched on the plan, belongs to this period of reconstruction and its foundations lie 0.50 m. above those of the main walls. There were several high floor levels which could be distinguished only in patches, occupying between them a vertical interval of 0.70 m.; thus in Squares C6 and D6 there was at 0.60 m. above the original floor a floor of clean clay overlaid with rubbish on which stood three inverted clay pots, one of Type RC. 1, fragments of a second similar, of Type RC. 7a, and of a large spouted jar and of a very large base-ring pot (Fig.8,f); in Square C5 there was a floor 0.30 m. above the main floor on which lay clay vessels, Type RC.7a and other fragments. Everything points to the repeated restoration and therefore to the relatively long life of this very solid building.

In Square C7 there was a distinct clay floor at 15.10 m., broken by rubbish-pits. In C8 at level 15.70 m. was part of a figurine in unbaked clay, a female (?) figure wearing a striated skirt, part of a second unbaked clay figurine, a sling-bolt of baked clay, two obsidian chips, two fragments of al 'Ubad painted pottery (clearly out of their true horizon) and fragments of baked bricks, flattened plano-convex, 0.19-0.20 m. wide with edges 0.045 m. thick increasing at the centre to 0.055 m.

In Square D8 a large pottery jar was embedded upright in the floor at the edge of our pit; the drain by the long wall ended at level 15.00 m.

In Square E7, on a stratum of ashes perhaps marking a floor at about level 16.00 m. there was a group of clay pots comprising Types RC.5a, (three examples), 7a (three examples), 16, and a number of animal bones. In Square E8, at level 15.50 m. two examples of clay Types RC.7a, 7b, two clay loom-weights and a bitumen handle (?); at level 15.10 m. some rubbish with clay vessels of Types RC.5a and 16, and also a type not found in the Royal Cemetery, JN.167. In Square F6 there was inverted in the soil at level 15.05 m. a heavily-ribbed bowl, diam. 0.80 m., and by it a libation-vase, Type RC. 16.

#### BUILDING STRATUM D. 14.30 m. above sea level.

There was a complete change of ground-plan here, for though a heavy wall still ran across the site from NE to SW it was now the containing-wall for a building lying to the NW instead of to the SE of it, and only a light wall and cross-wall of later date abutted on its outer (SE) face. The alignment of the buildings is also not the same in this and in the upper stratum, though the ruined walls of this stratum do in part serve as foundations for those of the next. The destruction of the walls is so regular as to give the impression that it was deliberate, due to the levelling of the site for the new building; very few small finds were made.

The upper part of the main or outer wall and all the rest of the walls were built of plano-convex mud bricks of a dark greenish-grey colour set in yellow mud mortar and plastered with the same yellow mud; in the foundations of the outer wall however there were also bricks of grey mud, rectangular instead of plano-convex, measuring 0.38 m. x 0.18 m. x 0.12–0.14 m. The wall foundations lay as a rule about the line 14.00 m. above sea level, but there was a total difference amounting to 0.30 m.: the space between the walls, up to floor-levels, was filled with very solid mud brick rubble; the lowest general floor-level was at 14.30 m. But constant repairs had raised the floors to higher and higher levels, so much so that in Square D7 the top floor was at 14.80 m., this suggesting a reasonably long life for the building.

In Square C6 a rubbish-pit belonging to Building Stratum B came to an end; in the bottom of it were four examples of clay cups, Type RC.5 and two of Type RC.7a, intact, and one of RC.16, broken; a large inverted bowl 0.75 m. in diameter probably also belonged to a higher level. In C7 was a miniature vase of white limestone, U.13732 of Type JN. 61; in the same square but perhaps belonging to the stratum above there was a pit going down to *circ.* level 13.80 m., at the bottom of which were ashes and numerous clay cups of Type RC.5a and 5b. In C8, 0.30 m. below the floor, through which it broke, was the base of a circular shaft which had first appeared (lined with drain-pipes) in Stratum A; in it was a collection of clay vessels including over fifty examples of Type RC.5a and many of RC.7a; all had been thrown intact into the shaft and many were found still unbroken; many contained small animal bones; a clay model wheel was found in the pit at a slightly higher level.

In Squares D6, D7 and F7 there were found examples of the clay bowl Type RC.1, all at or just below floor level. In Square C5, against the NW face of the main wall, at foundation-level, was a broken vase of drab clay, ht. c. 0.60 m., with a raised collar of ribbon ornament apparently of the shape shewn in Fig. 8,e. In Square C8 there was a seal-impression on clay, U.13853, not really legible.

**BUILDING STRATUM E.** 13.50 m. above sea level.

There was at this level a complete change in the lay-out of the buildings on the site; a narrow lane crossed the area from NE to SW and on either side of it were what seemed to be private houses. The stratification of the lane was unusually clear; from a point 14.00 m. above sea level (where it was cut off by the foundations of the wall of Stratum D) there was visible for the depth of two metres (i.e., in connection with both this and the next stratum) a succession of thin layers, all slightly concave, formed of broken pottery, ashes and well-trodden clay; each layer marks the re-surfacing of the lane.

The house on the SE side of the lane was built of mud bricks, very slightly plano-convex, measuring 0.20 m. x 0.13 m. x 0.055 m. at the edges increasing to 0.06 m. in the centre; that on the NW side of the lane was built of plano-convex mud bricks measuring 0.21 m. x 0.105 m. x 0.05 m. at the edge increasing to 0.07 m. in the centre; in the small chamber Square C4 there were in the middle of the floor some burnt bricks, flat and rectangular, 0.28 m. x 0.18 m. x 0.035 m., and with them fragments of plano-convex burnt bricks of uncertain length, 0.18 m. wide and 0.05 m. thick at the edges increasing to 0.06 m. at the centre; but it was by no means certain that these belonged to the stratum in which they occurred, as there were signs of a rubbish-pit here dug down from a higher level.

Not less marked than the difference in ground-plan was the difference in the pottery found on the floors of the rooms. This was best illustrated by the central chamber in the NW block in which the floor of trodden clay was thickly littered with clay vessels; these were for the most part lying in rows across the room, but as fragments of the same pot were sometimes found scattered over the room's area there had been a certain amount of disturbance, though not enough to confuse the stratification: the pots had been intact when placed in the room and many of them were found unbroken; *v.* Pl. 3,b. Without exception the pots differed both in shape and in ware from those found in the Royal Cemetery; some were spouted; cable ornament emphasising an angular shoulder-line, gashed ornament and incised hatching were common, and some vessels were distinguished by reserved slip decoration. An unusual vessel, represented by fragments only, was a large jar of red clay the rim of which was troughed to take a lid; on the outside of the rim were small vertical lugs to secure the lid and the shoulder was decorated with a row of triangular gashes above incised hatching, Fig. 8,h; with these were the stone vessels U.13754–13760.

In Square C4 just above floor level were fragments of a large vessel with thick walls of fine clay covered with a haematite wash and lightly burnished; with it were fragments of a vase of drab clay whose sides were decorated with narrow vertical strips of lighter-coloured slip applied as a paint and producing the effect of reserved slip ware but by a different technique; in the same room was a tall pot of rough reddish clay, Type RC.266. In Square C5 there was, above floor level, a bowl of black stone, Type JN. 26, U.13741, and an illegible seal-impression on clay; between the higher and the lower floor in this room were fragments of a wheel-made pot of black clay, smothered ware, with diagonal lines of burnishing on the shoulder and broader horizontal lines round the body, U.13752. In connection with the lower floor of the room was a drain-pipe 0.14 m. in diameter laid at a slight slope and running through the thickness of the outer wall of the house into the lane, where it was continued by an open trough drain, rectangular in section (like drains in the lowest house-levels at Kish) which ran at an angle with the first and followed approximately the line of the lane.

In the NW house, in Square C6, there was a white limestone bowl (U.13753, Type JN.14) broken and rivetted in antiquity, together with fragments of a second. In the room in Square C7 there were found a polished celt (U.13737), a clay pot of Type JN.41 and the upper part of a large clay vessel, spouted, with cable pattern at the base of the neck and reserved slip decoration on the flat shoulder; the type would seem to be JN.126. The SW wall of the room was broken by the drain which descended to this level; close to it there lay in a group a clay libation-vessel of Type RC.16, 0.90 m. high and 0.35 m. in diam. across the mouth, a number of plain cups and tumblers of Types RC.5a and 7a, a clay bottle of Type JN.72, fragments of three white limestone bowls and an upper grindstone of lava set in bitumen; these seem to be connected with the drain (they would lie within the area of its shaft) rather than with the room. In Square D5 there was a clay bread-pan, Type RC.1. In the room in Square D6 there was a solid packing of broken mud brick and below it (level 13.40 m.) a rough clay pot of Type JN.87, ht. 0.087 m., and one of Type JN.22. In the room in Squares 7-8 were fragments of a white limestone bowl of Type JN.22; also in a group together were fragments of a large clay libation-vase of Type RC.16, a cup, Type RC.5b and a tumbler, Type RC.7a; they were definitely later than the building as the wall had been cut away by the makers of the pit in which they had been put. In the pit in the middle of the room which was the bottom of a "drain" coming from above to this level, there were twenty or more cups and tumblers (Types RC.5 and 7) some nested one inside another, containing animal bones; these also were later in date than the building. The big drain already described in connection with Building Stratum B stopped here; the vertical series of ring pipes ended and from it a clay pipe 0.20 m. in diam. (0.25 m. at the mouth) ran at a slope and emptied into a large bottomless pot set upright; from the base of this another slanting pipe 0.55 m. long led down into a sump-pit which could be traced for some distance further down in the soil.

On the floor-level of this stratum and for half a metre above it fragments of stone vessels were noticeably common; most came from straight-sided bowls of types such as JN.19 (U.13756, 13757), but some shallow curved-sided bowls were represented, cf. Type JN.21 (U.13754-5). There were found also several carnelian ring beads, all rather large, with flat faces, coarsely made, and a seal-impression on clay, U.14112.

#### BUILDING STRATUM F. 12.80 m. - 12.40 m. above sea level.

The buildings of Stratum E were clearly a reconstruction on fairly similar lines of those now to be considered, but whereas the reconstruction was carried out in plano-convex bricks the walls of Stratum F were of rectangular mud bricks, flat-topped, measuring 0.21 m. x 0.11 m. x 0.07 m.; actually therefore we are now dealing with a different archaeological period.

The houses on the two sides of the lane seemed not to be of quite the same date, since their foundations differed in depth by as much as 0.50 m., with corresponding floor levels; the SE house, owing to its greater depth, was the better preserved and shewed signs of constant repair, there being a succession of floors separated from each other by only a few centimetres; the lowest was the best, of hard beaten clay overlaid with ashes.

In the small chamber in Square C4 there was found a spouted pot of light drab clay Type JN.123; in Square C5 on the floor were clay vessels of types RC.1, 7a, JN.133, and a clay rattle, U.13742; in Square C6 a clay pot with two spouts, U.13761, of Type JN.120. In Square D5 there was a little limestone figure of a standing bull, carved in the round and the eyes originally inlaid U.14407, Pl. 27; it was under the floor and may belong to this or to the earlier period. In Square D6, under a solid mass of broken mud bricks which might have been packing but more probably was the debris of the fallen walls there lay on the top of a bed of ashes a collection of beads U.13744; these were small carnelian rings and two very large ones, one or two lapis-lazuli rings and a quantity of shell rings with two small shell plaques, one oblong and one diamond-shaped. Close to them lay a second set, U.13745, a bracelet (?) of very small white shell rings and one small lapis-lazuli spacer. On the same level was a (broken) shallow bowl of diorite pierced with three holes, perhaps a vase-lid, U.13746, cf. Fig. 12, b, and a clay pot of Type JN.141. In Square D8 was a vase of very fine pinkish-grey ware with walls of almost egg-shell thinness, Type JN.77, U.13760 *bis*; in Square C7 a somewhat similar but coarser vase of the same type. In Square E8 there were numerous pots, some of them large store jars (too fragmentary to type) and several tumblers of Type RC.7a. The drain which, coming down from above, ended at this level in Square E7 had at its base a bowl of white limestone, Type JN.20, ht. 0.06 m., diam. 0.11 m., and numerous clay cups of Type RC.5b containing small animal bones and decayed vegetable matter; with them was one larger clay cup (diam. 0.18 m.) having the sharply-cut rim distinctive of Type JN.2.

Below this level the soil was extraordinarily hard, consisting of a solid mass of fallen mud brick in which it was difficult to recognise remains of standing walls. There had evidently been a phase of very thorough destruction followed by a period during which the site was neglected, for where any stratification existed it gave an alternation of decomposed mud brick resulting from the fall of wall masses with horizontal lines of water-laid mud.

## BUILDING STRATUM G. 12.20 m., above sea level.

The houses were not unlike those of the stratum above, lying on either side of the same lane; the walls were built of flat mud bricks measuring 0.21 m. x 0.11 m. x 0.07 m. but floors were seldom to be recognised. A great proportion of the pottery found in this level consisted of the curious elongated goblets of Type JN.25; these were very numerous indeed. A moderate amount of reserved slip ware still occurred and incised decoration was not uncommon, favourite designs being (a) crescents each made up of two curved lines impressed in the clay in slightly recessed mouldings and (b) a leaf (?) pattern in three elements, Fig. 8,i; fragments of plain burnished haematitic ware were found, also (in Square F6) a jar of light red clay Type JN.61, ht. 0.33 m. and a copper pin with ball head. The normal cups and tumblers, Types RC.5b and 7a were still common, Type RC.1 occurred, several examples of Types JN.77 and JN.128. More symptomatic were examples of a plum-red ware with powdery paint, not burnished, and (rarely) of burnished red-and-black Jamdat Nasr wares; the angular shapes of the Jamdat Nasr period predominate, and for the first time we encounter looped ribbon handles. The Type JN.13 (in plain drab clay) is also early; it was found in Square E4; from Square D8 but rather below foundation-level came a specimen of Type JN.67 and a fragment of a red-ware pot with applique ornamental ledge handle, Fig. 8,j. In Square D6, also rather deep, were two examples of the regular Jamdat Nasr vase Type JN.146, and fragments of plain plum-coloured ware.

## BUILDING STRATUM H. 11.00 m. above sea level.

The buildings were relatively speaking well preserved and consisted, like those of the levels above, of two houses facing each other across a narrow lane. The walls were built of rectangular mud bricks similar to those in the stratum above, but in the case of the NW wall of the NW building (Squares C-E8) and of the prolongation of the SE wall of the same building (Square C6) the brick rested on foundations of coursed limestone rubble. The stones were for the most part small, averaging about 0.30 m. in length (18 gave a wall-length of 4.80 m.) and were not dressed at all; there were two rows forming the wall faces and between these the space was filled with mud brick; in the NW wall the outer or NW line of stones lay 0.25 m. higher in the soil than those of the SE face and was two courses high (0.60 m.). All floors were of trodden clay, except in the case of the small room in Square C4 where the floor was covered with bitumen; the clay floors had generally been repaired a number of times and the highest levels shewed a rise of as much as 0.80 m.

In Square C4 immediately below the bitumen pavement lay several clay tumblers of Type RC.7a, a broken reeded handle from a large vase and a fragment of a vessel of pinkish drab clay with horizontal bands of red paint; also numbers of fragments of spouted pots too small to be typed. It is noticeable that the goblet Type JN.25 which was common in the stratum above, disappears from now on.

In Square C5 a large tumbler of red clay, Type RC.7a, and fragments of a red bowl of Type RC.5b were not symptomatic. In Square C6 came a fragment of a clay jar-stopper with seal-impression of a spread eagle, U.14505, Fig. 9,a; also part of a flint hoe of normal al 'Ubaid type and a mace-head (broken) of baked clay, fluted and covered with a wash of plum-red paint, U.14414, Pl. 15. In Square C7 there were two white limestone mortars with their hemispherical pestles or rubbing-stones and four rough limestone pounders together with a painted pot of Type JN.52 (U.14418), a red clay vase Type JN.67 and fragments of plum-coloured painted ware. In Square D4, let into an intermediate floor-level of well-trodden mud there were three patches of broken pottery and one of rough stone and below each was a clay pot, one of them set in bitumen; against one of the pots was half of a burnt brick, flat rectangular type, 0.10 m. wide x 0.075 m.; the pot itself was an unusually large beaker of Type JN.19, 0.30 m. high (U.14949), inverted in the earth; the fragments of pottery over this and the adjoining pot were of one kind and belonged to a disk 0.75 m. in diam. and 0.065 m. thick having at its centre on one side a circular depression surrounded by a raised ring; on the other side close to the rim were some small holes apparently made by and to receive a stick; it was certainly a potter's wheel. The pot under this patch was a jug of pinkish drab ware with a loop handle, Type JN.165; the fourth pot was only the base of a large vessel.

In Square D5 there was a drain running out into the lane through the thickness of the wall; it consisted of a single length (0.40 m.) of terra-cotta trough, rectangular in section but open at the top with sides 0.04 m. high which inside the room were heightened by fragments of pottery embedded on edge in the mud of the floor; it resembles exactly the drains in the lowest house levels at Kish.<sup>1</sup>

In Square D6 there was a considerable quantity of pottery lying on the floor; U.14429, an example in pinkish clay of Type JN.102, with three small lugs on the shoulder; U.14427, Type JN.130: a broken example of Type JN.78: U.14421, miniature examples in red clay, of Type JN.163 (Fig. 10): U.14441, of Type JN.79, in light red clay: U.14442, of Type JN.126, in drab clay: a broken specimen in pinkish drab clay of Type JN.80: one in very light drab clay of JN.132, and examples of Types JN.67 and perhaps

<sup>1</sup>L. Ch. Watelin, "Rapport sur les fouilles de Kish" in *Journal asiatique*, 1929, p. 106.

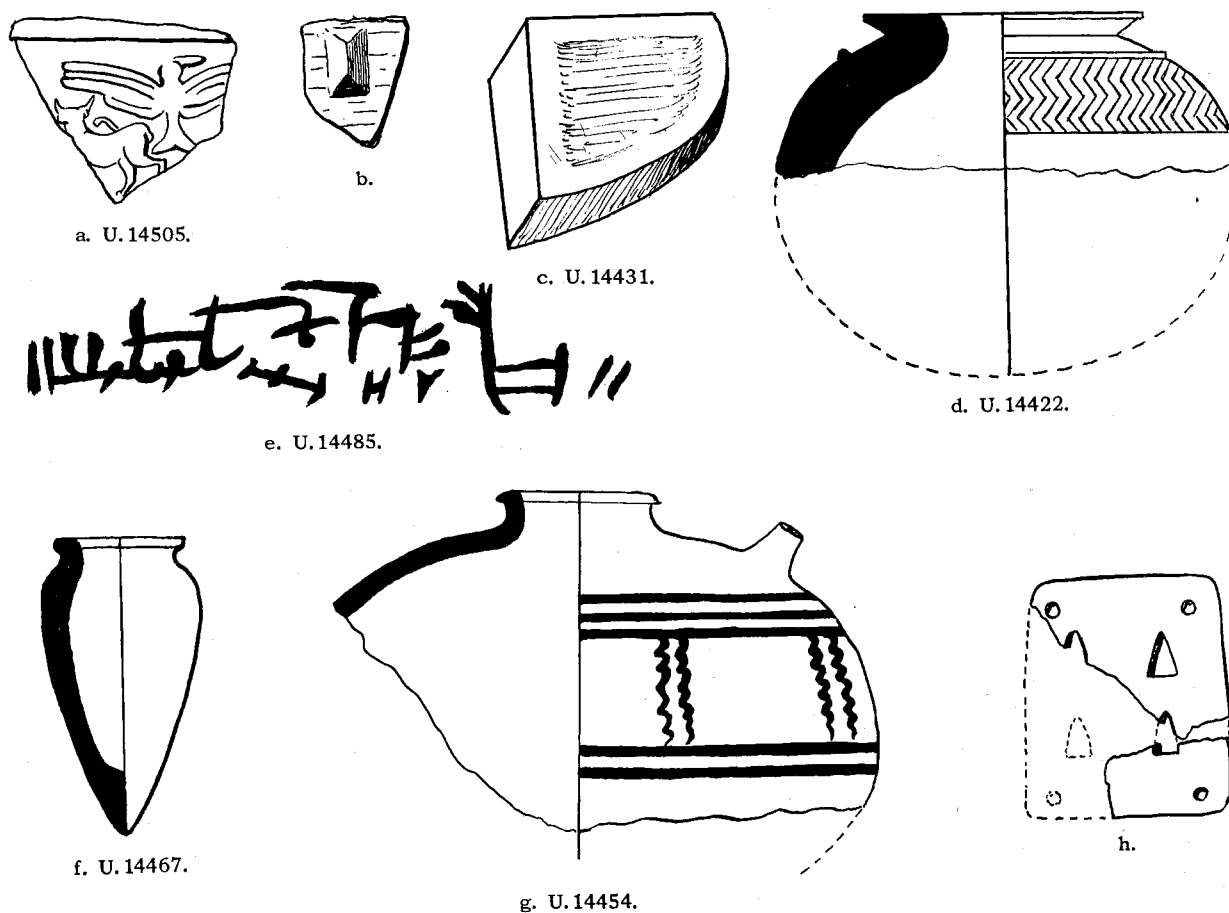

Fig. 9.

aU.10: U.14428, in drab clay, Type JN.102: two spouted vessels, one of Type JN.127 and the other (fragmentary) more of bowl form with bands of red paint on a whitish ground: with all these were fragments decorated with impressed string pattern and one with a band of red paint on a reddish drab ground. Here too was an early occurrence of glaze, U.14422, a small vase of white frit having a broad rim and impressed ornament on the shoulder, Fig. 9,d, also a clay wall-decoration cone with its blunt end painted black; at a slightly lower level, immediately below the floor on which the pots lay, was a bowl of veined calcite, Type JN.9 (U.14420), a copper pin or tool U.14415, Pl. 30, and a fragment of a seal-impression on clay, U.14568.

In Square D8 there stood on the floor an intact bowl U.14455, 0.75 m. in diameter, of red clay with a roughly-painted decoration in black below the rim and a relief band of crinkled ribbon decoration, v. Pl. 45; close to it was a clay bowl, diam. 0.40 m., plain, with knife-trimmed rim. The ring-drain which descended from above into this stratum had

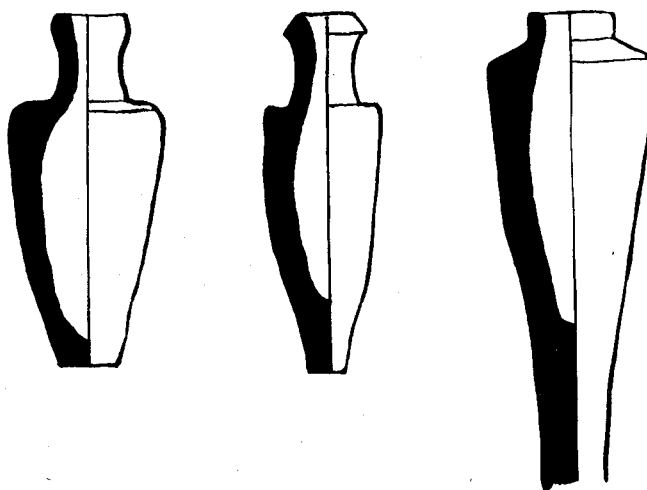

Fig. 10. Examples of miniature vases.

at its base animal bones and 16 clay cups all intact or only slightly broken; the ring-drain running through Square F8, the starting-point of which could not be traced owing to the telescoping of the rings, had in its packing a burnt brick, flat and rectangular, 0.34 m. x 0.31 m. x 0.08 m. In Square E7 there was a rectangular mud brick 0.29 m. x 0.26 m. x c.0.08 m. lying 0.60 m. above floor level. In the same stratum, level 11.20 m., was found the upper part of a clay bowl with decoration in red paint curiously like an inscription, U.14485, Fig. 9,e, and a seal-impression on clay, U.14550.

Below Building Stratum H there were remains of earlier buildings in burnt and mud brick and traces of stone foundations, but they all had been so thoroughly destroyed that no ground-plan could be traced; there were scattered elements of walling and patches of clay floor at different levels, the lowest of which went down to 9.50 m. above sea level, at which point the kilns begin; the interval of 1.50 m. between Stratum H and the kilns is therefore best treated as one level, though it may contain buildings of different ages. Stone foundations occurred in Square C6 at level 10.30 m., in Square C8 at level 10.00 m.; burnt bricks in position in Square D7 at level 9.80 m., in Square D4 at level 9.90 m. and in Square D5 at 9.50 m.; in E7 there was a good mud floor laid over broken burnt bricks at 9.50 m., mud walling in Square C6 at level 10.10 m. and at the same level in Square D8. Most of the burnt bricks were of good quality but there were others so powdery that they could not be extracted from the soil.

In the upper part of the stratum, down to 10.00 m. above sea level, the following pottery types occurred; – in Square C4, fragments of a tubular-spouted bowl in plain clay, fragments of reserved slip ware, fragments of creamy ware with broad bands of plum-coloured paint, fragments of a coarse red pot with solid triangular lugs, Fig. 9,b; in Square C6, plain clay pottery of Types RC.5b, 7a, (one containing animal bone and ashes), Type JN.19 (an unusually large example, 0.19 m. high), Type JN.154, a spouted bowl (U.14444), ht. 0.095 m., fragments of plum-coloured painted ware, fragments of a vase of greenish clay with bands of chocolate paint and of a blue-grey "smothered" pot, slightly burnished; a clay "nail," a clay sling-bolt, an obsidian chip, a bitumen jar-lid, a ribbed bead of black steatite. In Square C7 an example in red clay of JN.76 (U.14443); in Square C8 was a group of cups and tumblers of Types RC.5b and 7a and a burnt brick triangular in shape with the base of the triangle curved, one face flat and the other slightly concave, U.14431, Fig. 9,c. In Square D4 was a fragment of a clay sickle, in Square D5 a fragment of a pot of red ware with fine curved stripe burnishing, a large pot ht. 0.65 m. of light cream-coloured clay, Type JN.59 inside which were 17 cups of Type RC.5b and a small bottle of Type JN.86 (U.14475). In Square D6 was the upper part of a large pot with loop handle, Type JN.107, diam. 0.35 m.; in Square D7 a curious solid block of baked clay shaped like a bowl with a band of crinkled ornament round the shoulder, possibly a vase-stand, U.14430, Type JN.160. In Square D8 were fragments of plain plum-red painted ware and of buff ware with red bands, and also the first examples of true Jamdat Nasr polychrome. In Square E4, tumblers of Type RC.7a. In Square E6 numerous fragments of pottery including U.14445, a rough miniature in red clay of Type JN.91, an example of Type JN.146 in drab clay, a double reeded handle and a bit of al'Ubaid ware with black paint on greenish ground. Squares F4-8 produced plain red (unburnished) and painted plum-coloured wares, pink or buff wares with red painted bands, but no Jamdat Nasr polychrome pottery.

In the lower part of the stratum, between 10.00 m. and 9.50 m. above sea level, there is a definite change characterised by the comparative abundance of Jamdat Nasr pottery. Keeping to the record by squares, we may note:– in Square C4, 3 fragments of Jamdat Nasr ware, many of plain plum-coloured ware and of bright red ware with criss-cross patterns, one with black design of thick al'Ubaid ware, also a flint hoe, and a double reeded handle of buff clay. In Square C5, 3 fragments of Jamdat Nasr ware, many of plain plum-coloured and with red bands on a light ground, a triple reeded jar-handle with applied ornament in "snowman technique," plain pots of Types RC.7a and JN.145 (U.14492). In Square C6, plenty of the plain red and plum-coloured wares, a large spouted jar with design in chocolate brown on a light red clay, U.14454, Fig. 9,g, and a miniature vase of Type JN.163; a fragment of a painted clay figurine of a woman, U.14423, Pl. 22, a brick made of white cement, rectangular and flat, 0.21 m. x 0.095 m. x 0.06 m., U.14451, and a clay seal-impression, U.14615. In Square C7, fragments of Jamdat Nasr ware, many of plain red, fragments with chocolate paint on a buff ground, a plain bowl of Type JN.3, ht. 0.045 m., diam. 0.09 m., and a miniature vase of Type JN.163; also fragments of a hemispherical diorite bowl and fragments of burnt bricks, rectangular and flat, 0.11 m. wide x 0.07 m. thick.

In Square C8 plain red wares both matt and burnished, plum-coloured painted wares and stripe-burnished pinkish wares were common; a twisted handle from a large vase, a bent clay "nail" and a large cone for wall inlay occurred, as well as a few fragments of painted al'Ubaid pottery. In Square D4, fragments of very fine Jamdat Nasr polychrome ware, examples of creamy buff ware with hatched triangles in chocolate-brown paint, plain red ware (common), plain wares of Types RC.7a, RC.83b (U.14491), JN.5 (U.14937), JN.68; also a miniature stone vase of Type RC.106 (U.14481), a crystal pendant U.14477, a copper needle and a clay animal figurine. In Square D5 there was the upper part of a very good Jamdat Nasr vase U.14472 and fragments of two others, much plain red and plum-coloured ware and light ware with red or chocolate-brown painted bands, and one fragment of painted al'Ubaid pottery. In Square D6 numerous Jamdat Nasr fragments and others in plain red and plum-colour or in light clay with red bands, several 3-reeded handles, part of a bowl with carinated rim with red bands round it, plain vessels of



Types JN.68, 130, 149 and 163, and U.14467, Fig. 9,f, and two fragments of al 'Ubaid painted pottery; also part of a painted clay figurine, U.14424, Pl. 22, a steatite cylinder seal, U.14478, Vol. X, No. 30, and two fragments of terra-cotta plaques at least 0.50 m. x 0.31 m. x 0.05 m. thick pierced with triangular holes, Fig. 9,h; they were possibly gratings from pottery kilns.

In Square D7, a (broken) three-coloured Jamdat Nasr vase and other fragments, an example of reserved slip ware and of the red and plum-coloured wares and light with red painted bands, 2 miniature vases, plain, of Type JN.163, one of Type RC.7a, one of Type JN.67 and of Type JN.69, a fragment of a black and white marble bowl, a bent clay "nail," two copper fish-hooks, U.14439, Pl. 30 and U.14447, Pl. 30, a copper chisel, a copper spear-head U.14440, Pl. 30. In Square D8, fragments of a fairly large pot of light buff clay covered with a creamy slip on which a design of trees and cross-hatching in chocolate paint, and fragments of a very large bowl roughly painted with bitumen; similar banded wares and bright red wares were freely represented; there were several small cones for wall mosaics, five ribbed steatite beads U.14479, a marble pendant U.14482 (Pl. 16), numerous copies in clay of long tubular shell beads, U.14480, and an oval stone stamp seal U.14476, Pl. 44. In Square E6, fragments of Jamdat Nasr ware, and of wares of lightly-burnished salmon-pink clay, plain red and deep orange painted wares and light with red or chocolate bands; also plain pottery of Type JN.146; with them part of a mud jar-sealing with seal impression, U.14457, Fig. 11,a, and a black stone rosette, U.14446, Pl. 44. In Square E7, fragment of a jar-sealing in black clay with seal-impression too incomplete to give the design.

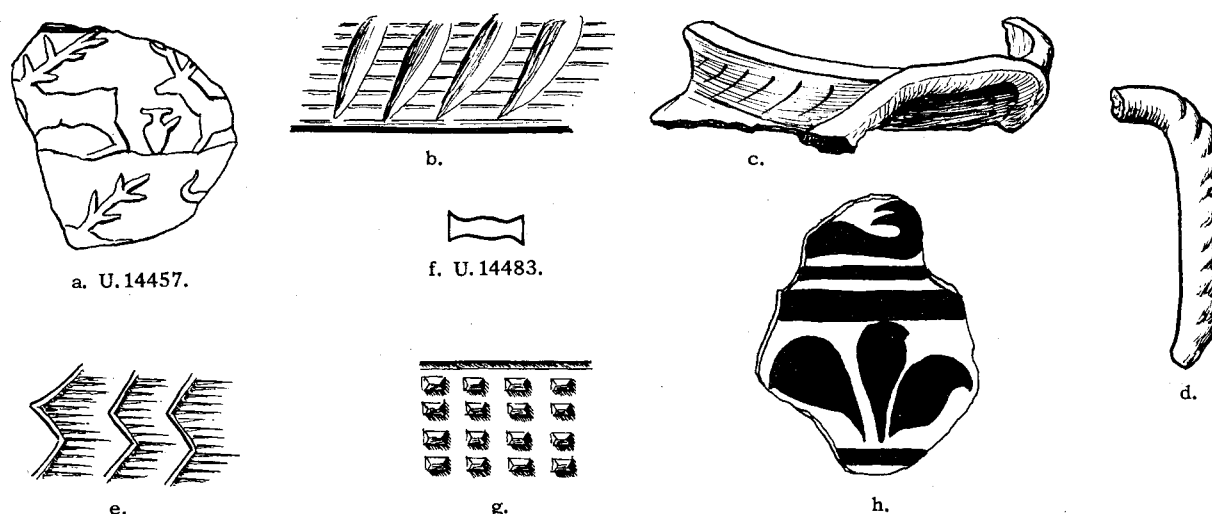

Fig. 11.

Practically all trace of house walls had by this time disappeared, and the soil was no longer composed as hitherto principally of the debris of decayed mud brick; from the lowest house foundations down to 5.50 m. above sea level we dug through an almost solid mass of potsherds mixed with ashes. A very great many of the broken pots could be recognised as "wasters," i.e., vessels which had been cracked or distorted in the firing and were thrown away by the potters as having no commercial value; the process had been gradual and masses of pottery would be overlaid by layers of ash from the kilns, but such would not extend over the entire area but formed patches of limited extent; consequently there was no accurate stratification by floor levels and depth was the only possible criterion for relative dating; in what follows therefore the contents of the stratum as a whole are described in successive strata of half a metre's depth each: it must be remembered that these are purely artificial, and there is no reason to suppose that at any one time there was really a dead level extending over the whole area excavated by us: but the succession of arbitrary half-metre strata will give a fairly accurate impression of such changes as occurred during the period in which the dump was formed.

But before describing the pottery fragments it is necessary to describe the kilns. At varying levels there were found, buried in the mass of wasters, the actual kilns in which they had been fired. The kilns had been used each many times and constantly repaired, but the potsherds flung out at random around them had accumulated until in time the ground level had risen above the top of the kiln and a new one had to be built at a higher level; the ruins of at least fourteen were discovered with a maximum interval between their foundations of 1.90 m.: the period during which the factory was active is likely to have been a fairly long one.

The kilns (v. Pl. 3,c and d) were circular and though differing in size were all of approximately the same pattern. That on the line of Squares C-D6 may be taken as an example. Below it was a circular

pit 0.90 m. in diameter and 0.35 m. deep, lined with fire-clay and originally roofed with brick (the bricks were fused by the heat into shapeless clinkers); holes 0.10 m. in diameter and 0.45 m. apart (with a larger one in the centre) led the heat from the furnace to the kiln above; channels cut in the soil sloped down to holes in the sides of the furnace and supplied draught. The kiln proper was 1.30 m. in diameter, the ledge 0.20 m. wide round the rim of the furnace-pit serving as a support for the roof of the latter; the walls were of bricks measuring 0.22 m. x 0.105 m. x 0.085 m. or 0.20 m. x 0.095 m. x 0.095 m.; these were set in clay mortar and were liberally plastered with fire-clay which had been burnt by the heat to a greenish-white, while the soil round was deep red, shewing that the kiln was in part buried so as to preserve longer the heat of the furnace; the roof of the kiln was rebuilt for each firing and destroyed so as to remove the pots when the firing was complete. In one case the last batch of pots to be fired was found still in the kiln, Pl. 3,c, rough "flower-pots" with knife-trimmed rims of a sort (Type JN.2) characteristic of the period. By the kiln on the line of Squares C-D5 there was a clay lead-trough, 0.20 m. long and 0.04 m. wide, rectangular in section, which seemed to be connected with the draught system. In Square D5 at level 8.40 m. we unearthed, against the side of our pit, part of a circular basin which probably served for puddling the clay used by the potters; it was built with three courses, stepped outwards, of cement bricks measuring 0.44 m. x 0.16 m. x 0.09 - 0.10 m.; against it but at a somewhat lower level was a short length of straight wall built of ordinary bricks 0.23 m. x 0.10 m. x 0.08 m.; close to this stood in position a group of six clay pots of Type JN.113 (Pl. 4a), probably a batch connected with the old kiln now represented by the straight piece of wall only. In Square C7, at level 8.80 m., there remained three sides of a small brick box or enclosure built with cement bricks measuring 0.40 m. x 0.18 m. x 0.11 m. (Pl. 4a). In Square E7 at level 7.50 m. there were found loose in the soil two cement bricks measuring 0.20 m. x 0.08 m. x 0.08 m.; at the same level there was in Square C6 a burnt clay brick, also isolated, of purely flat shape, measuring 0.205 m. x 0.085 m. x 0.065 m., matching the cement bricks. One of the kilns in Square D4, of which only part of the furnace survived, was built partly with cement bricks measuring 0.20 m. x 0.08 m. x 0.06 m. and partly of clay bricks 0.20 m. x 0.11 m. x ? m., the tops being too much destroyed for the thickness to be ascertained. In Square C4 a patch of bricks lying flat with bitumen below them gave measurements 0.285 m. x 0.215 m. x 0.06 m.; in Square D7 at about the same level (c. 8.60 m.) was part of a burnt brick of unknown length, 0.095 m. wide x 0.045 m. thick, having two small holes drilled through it towards one end. It is clear that the period represented by the kilns saw several types of building-brick employed and as at Warka similarly different types characterise buildings of distinct periods we are compelled to conclude that the Ur factory was reasonably long-lived.

Of the pottery, the plain types most common were the "flower-pot" Type JN.2, Types RC.5b and RC.7a; and Types JN.68 and 163: there also occurred the spouted forms Type JN.146, and JN.121, and the handled bowl Type JN.107. The "flower-pots" were in many cases distorted and even fused together in sets of three or four, and it was evident that these and the tumbler and shallow cup forms (RC.5b and RC.7a) were the main output of the factory during this stage. The plain red burnished wares were represented by a good example, shewn on Pl. 26 (U.14909), and by fragments, including one of greenish clay covered with a wash of deep orange brown highly burnished, an unusual colour; there was an example of fairly elaborate curvilinear design in red on pinkish cream clay and others more simple, and rather more than a dozen fragments of painted al 'Ubaid ware; none of the characteristic 3-colour Jamdat Nasr pottery was found; one fragment of unpainted ware had an incised decoration of hatched triangles and another a combination of pressed and combed ornament, Fig. 11,b. Other objects were: two clay "nails," one medium sized clay cone for wall mosaic, two clay beads made in imitation of the long tubular shell beads, and one of shell; beads of black steatite (tubular) and of blue glaze, U.14469, a large flat circular bead of marble, U.14465a, a rock crystal ring bead, a fluted carnelian ball bead and a mother-of-pearl oval pendant; a bone pin U.14484, 3 copper pins, a small curved copper blade, a flint hoe, a clay spoon, U.14462a, a clay spindle-whorl, U.14464, a clay spool, U.14466, and fragments of a small vase of white frit covered with a pale turquoise glaze, U.14908 (Pl. 26,g).

#### Level 9.00 m. - 8.50 m.

At the level 8.65 there were found loose in the soil two kiln-fired bricks of which one measured 0.23 m. x 0.09 m. x 0.07 m. and the other 0.20 m. x 0.09 m. x 0.07 m. and by them a cement brick 0.21 m. x 0.09 m. x 0.06 m.; at 8.70 m. was a brick lightly fired and very crumbly which appeared to be somewhat plano-convex, but this may have been due to the decay of its surface; it measured 0.21 m. x 0.11 m. x 0.07 m. rising to 0.08 m.

The pottery shewed a remarkable mixture of types; there were masses of plain wares, three or four pieces of Jamdat Nasr polychrome ware, a few specimens of the red or chocolate-brown bands on a light clay, some plum-coloured unburnished ware, much burnished red and a considerable quantity of painted al 'Ubaid sherds, also a good deal of buff ware with combed and incised ornament; of the painted ware there were actually recorded seventy odd specimens of burnished red, a dozen or so of unburnished plum-coloured, fifty-five of al 'Ubaid type and four of Jamdat Nasr; the proportion naturally differed in the

different squares, but the general results were consistent. Unusual types were (a) fragments of a finely burnished vase of black ware, U.14913, (b) fragments of stripe-burnished orange-brown ware, (c) fragments of a plain bowl with the rim elaborately nicked, Fig. 11,g, (d) part of a plain bowl of greenish clay with loop handles rising from the rim, Fig. 11,c, (e) fragments of several jugs with twisted handles, Fig. 11,d: plain types included a number of rings which seem to be ring bases for pots, separately made and accidentally not used by the potter, Types JN.150, 163. Other objects found here were: fragments of buff or greenish pottery with combed or scrubbed ornament, Fig. 11,e; numerous clay cones for wall mosaic, including, U.14500a and another unusually large example; three clay sickles, U.14926; a decorated spindle-whorl U.14931; several clay "nails;" long clay beads imitating those of shell (U.14928) and a similar bead in stone (U.14929); a stone handle, (U.14925); a curious bead of black steatite, U.14483, Fig. 11,f; an amulet in the form of a bird in pink stone, U.14494, Pl. 28; two fragmentary seal-impressions on clay, U.15021-2; a cylinder seal, U.14495, Vol. X, No. 28; and most important of all, the remarkable steatite figure of a crouching boar, U.14459, Pl. 37, on which see p. 31.

#### Level 8.50 m. - 8.00 m.

In this stratum the number of the various decorated wares recorded was as follows: Jamdat Nasr polychrome, none; unburnished plum red, 4; red bands on light ground, 1; incised ornament, 4; plain burnished red, 38; al 'Ubaid painted, 47; reeded handles, none; twisted handles, 5. The six plain pots found standing in order against the kiln were all of the same sort, Type JN.113, ranging in height from 0.44 m. to 0.75 m., of light red or drab clay. There was found one example of Type RC.1 and the curious little phallic flask U.14930, Pl. 44; also a few fragments of clay sickles, cones for wall mosaic and bent "nails;" also a flint hoe of normal al 'Ubaid form, two flints set in bitumen, U.14920, a copper fish-hook, U.14924, Pl. 30, a copper spear-head U.14980, Pl. 30, and a steatite cylinder seal U.14489, Vol. X, No. 31.

#### Level 8.00 m. - 7.50 m.

The pottery recorded was as follows: Jamdat Nasr polychrome, none; plain burnished red, 87; unburnished plum-coloured, 5; red bands on a light ground, 4; al 'Ubaid painted types, 64; incised or stamped ornament, 4; light red unpainted stripe-burnished ware, one; plain ribbon handles, 6; double reeded handles, several; twisted handles, 6. Of the plain ware the overwhelming proportion consisted of "flower-pots" (Type JN.2); two complete examples of Type JN.131 were found, (U.14963) and one each of Types JN.15, 29, 69 and 108; also several clay rings which seem to be base-rings made separately and intended to be fixed to clay vessels before firing, but actually never used by the potter (U.14945). Other objects from the stratum were a flint hoe, U.14932, and a second similar, a clay spool U.14941, a clay tool (smoother?), U.14939 (Pl. 45), a black pebble pierced perhaps as an amulet, a copper pin, U.14952 and an amazonite bead U.14940, a copper fish-hook U.14969, Pl. 30; some beads, U.14965; another clay smoother, U.14938, Pl. 45; some plum-coloured paint in the bottom of a pot; a small clay object of uncertain use, U.14948, and a seal-impression, U.15022, Vol. III, No. 331.

In this stratum there was a very definite surface, a floor of beaten clay which presumably was at one time the floor of the factory area. It was not uniform, but starting in Square C4 at level 7.90 m. it dipped down to the NE so that in Square D4 it lay at 7.00 m.; in Square D6 it was at level 7.35 m. and in Squares C5-6 at 7.00 m.; it was thickly littered with "flower-pots" (JN.2) many of which were intact; on it were also five cups, Type JN.19, a large example of JN.59 (0.40 m. in diameter), and one of JN.68.

#### Level 7.50 m. - 7.00 m.

The pottery recorded was: Jamdat Nasr polychrome, none; plain burnished red, 46; unburnished plum-colour, 5; red bands on a light ground, 2; al 'Ubaid painted types, 73; incised or stamped ornament, none; light red unpainted stripe-burnished, 2; twisted handles, about 10. The "flower-pots," Type JN.2, were innumerable; one example of Type JN.12 was found. Other objects were, two fragments of clay sickles, a flat date-shaped bead of polished crystal and a flint hoe.

#### Level 7.00 m. - 6.50 m.

The pottery recorded was as follows: Jamdat Nasr polychrome, none; plain burnished red, 23; unburnished plum-colour, 4; red bands on a light ground, 2; al 'Ubaid painted ware, 82; incised or stamped ornament, one; no handles. Pottery forms, other than the "flower-pot" Type JN.2 were Type JN.70 (U.14964), 24 and 118. Other objects were an animal figurine, U.14979, Pl. 24; a clay disk of uncertain use, U.14982; a clay jar-stopper with seal impression, U.14981 (No. 240 in Vol. III); some very small white paste beads, a double conoid bead of blue-glazed frit, and a ring-bead of amazonite; also a fragment of a clay sickle.

#### Level 6.50 m. - c. 5.50 m., the bottom of the "factory" stratum.

There was a definite break in the rubbish caused by a layer of clay which extended more or less horizontally but with a dip to the NW over the excavated area; at the extreme NW a kiln had been con-

structed in this lower stratum but of course belonged to the level above; below the clay layer the "flower-pots" which had been so common hitherto were noticeably absent. The pottery shewed that the change which had been taking place in the strata above was now definitely accomplished: whereas the collected potsherds gave us 729 examples of al 'Ubaid painted wares, there were only 4 specimens of burnished red, none of plum-coloured, none of incised or of red bands on a light ground; there were 2 twisted handles, 2 loop handles and one each of the plain ribbon and the double reeded handle. Fragments of clay sickles were common, as were bent clay "nails;" large clay cones for wall mosaic with hollow heads occurred; several ovoid clay sling-bolts; two clay disks pierced by two holes; spindle-whorls of baked clay; a flint core; a quartzite arrow-head, U.15333; a baked clay pin l. 0.045 m.; several clay figurines including U.15334, Pl. 23, and a bitumen ring, *v.* Appendix VI (b).

In the lower part of the stratum the potsherds were less thick in proportion to the earth and ashes, and there were at the NW end of the excavated area fairly definite surface-levels of trodden soil – it would seem that there had been an interval between the formation of the next underlying stratum and the opening of the pottery works. On the NE face of our pit (along the line F in Squares E6 and E7) there was a dip with strongly sloping edges filled with alternate black and grey layers containing numerous fragments of pottery all lying quite flat; the real pottery stratum ran over the top of this; it was obvious that there had been here a pool which had gradually filled in and dried up before the main activities of the factory began. In Squares D5 and E7 there were burials in the pottery stratum but at the very bottom of it; in the former case there were eight bodies heaped together in confusion in a pit 2.00 m. x 0.60 m. and in the latter ten bodies apparently thrown in pell-mell. These are treated of in the detailed description of graves.

The next stratum consisted of a bed of clean water-laid silt with an average thickness of 3.50 m.; it was throughout clean, uniform and consistent. In places it had been disturbed, in some places very much so, by graves which had been dug through it or into it, and although the grave pits had been filled in again with what was generally the same clean silt containing scarcely any or no adventitious potsherds or rubbish, the stratification here had necessarily been destroyed; the description given is based on the examination of the undisturbed soil between the graves.

As to the character of the silt there could be no doubt; the analysis,<sup>1</sup> makes it perfectly clear that it is the type of deposit normally left by the Euphrates in flood, collected from the upper reaches of the river; it is fluvial, not marine. The practical absence of stratification shews that it was deposited all at one time and is not the result of repeated minor floodings; but to this there is one possible exception. Over the greater part of the area, where observation was not defeated by the disturbance of the soil due to the grave-diggers, no break in the uniformity of the deposit from top to bottom could be detected; here and there there might be a "pocket" of material of a different character, rubbish such as would be carried along by the swirling waters as they passed over an inhabited site, but such were isolated and discontinuous; incidentally in them the action of water was particularly manifest as in them the varying colours of the mud and rubbish brought out the lines of stratification. But in one part at the NW end of our excavation (Square E6) and more decisively in the south corner of it there was a band of darker material about level 4.50 m. which did look more like a surface; and in the south corner (Squares C4, D4) from a thin horizontal stratum composed of very fine layers of sand and grey mud with a few potsherds there go down three definite pits filled with rubbish and sand, pits which cannot be traced above the horizontal line and therefore must have been dug from its level.<sup>2</sup> Consequently there would seem to have been an interruption in the process by which the great bed of silt was formed, an interval during which the 4.50 m. level was above water and formed a ground surface, after which it was again flooded and another metre of silt deposited upon it. There is nothing in the stratification to shew how long that interval may have been, and the obvious deduction from the thinness of the rubbish strata is that it was short. On the other hand the graves belong to two different phases; in the first place there is the question of depth; a number of the burials are found actually above the silt (and these obviously belong to a time when a certain amount of soil and potsherds had accumulated above the silt) or so close to its surface that, allowing for even a very modest depth for the grave shaft one has to assume a higher ground level than that afforded by the silt itself. Other graves lie so deep in or under the silt that the shafts would seem to have been improbably long had they started from anything like the same level or even from the surface of the silt; it would be possible to dig a small shaft 4.50 m. deep in the fairly stiff clayey sand of which the deposit is formed, but it would be neither easy nor necessary, and it does not seem to have been in accord with the normal practice: personally I should in any case have concluded that the two series of graves were originally dug from different ground levels. An examination of the furniture of the graves shews that the upper and lower series are distinguished by a marked cleavage in the pottery types (in particular, the pedestal vase Type aU.9 which is almost invariably present in the upper graves is unknown in the lower), and this would tend to prove that there was a definite interval of time between the two series. The lower graves belong to people

<sup>1</sup> *v.* Appendix VI (d).

<sup>2</sup> In this stratum, in Square C4, was found a small rod of dark opaque glass.

who occupied the site immediately after the first silt bed, 2.50 m. thick, had been formed; the upper graves belong to the people who, after a second and less serious inundation resulting in the deposit of another metre of silt, had for some time been utilising the area as a site for a vase factory.

The silt ends not in a straight line but resting on the irregular surface (c. 2.00 m. – 1.00 m. level) of mixed rubbish containing all the debris of an occupied site. At the NW end of the excavated area (Squares C7, D7, E7) there were three quite definite floors of trodden clay one above another; in Squares C-D4 and D5 two less well-marked surfaces could be distinguished. In Squares C-D4, at level 1.90 m., there lay on the top of the rubbish stratum a mass of fallen bricks still held together by mortar; the mortar (mud) had been burnt to a deep red by some accidental fire; the bricks were also burnt but it was hard to say whether this was due to the same accident or whether they were truly kiln-fired; my first impression was that they were kiln-fired bricks, but the other theory is more likely. The bricks were rectangular and flat, measuring 0.30 m. x 0.16 m. x 0.065 m., with one of a different size, 0.19 m. x 0.15 m. x 0.075 m.; another appeared to have been 0.22 m. long, but as these were broken specimens the measurements were not to be trusted. The mortar in the horizontal joints varies from 0.02 m. to 0.013 m. in thickness. In Square D5 there was a mound composed of masses of partially burnt clay resulting from the destruction by fire of a reed-and-daub hut (v. p. 7); elsewhere the stratum contained no evidence of actual buildings but was made up of normal refuse. All the pottery was of the regular al 'Ubaid types – the majority of the pieces plain but very many painted and these tending to illustrate the "all-over" patterns which we suppose to be characteristic of the earlier period. Very numerous were querns and rubbing-stones generally oval in shape, 0.30 m. x 0.20 m., and convex below; clay disks with two holes in them (v. Fig. 4) were very common, as were clay sickles and bent "nails" and spindle-whorls; flint hoes occurred freely, there were two polished celts (U.15583-4, Pl. 14) and a broken bowl containing obsidian flakes; in Square E7 there was part of the base of a bowl finely worked in black and white marble; lumps of bitumen preserved the imprint of basket-work. In Square D7, at Level 2.20 m., there was found a fragment of a large vessel of al 'Ubaid ware, of whitish clay with design in black paint, Fig. 11,h.

The base of the occupation-stratum was at 1.10 m. above sea level; it rested on what was clearly a surface, the dried surface of what had been a marsh. Our work was carried down to the depth of a metre below sea level, a depth at which signs of human occupation could hardly be expected; the soil was a heavy green clay pierced in every direction by rust-coloured fibrous stains which represented the roots of plants; as it rose towards sea level the green clay changed to brown, at sea level. Up to this point the soil was absolutely clean and contained no potsherds or other evidence of human life. The clay must have been the bottom of the marsh which covered the deltaic land before it rose above sea level; the rise was due in part to the silt regularly deposited by the river, in part to the decay of the reeds which grew freely in the marshland. On the brown surface there rested a layer about one metre thick of black mud of an organic nature, resulting from the decay of vegetable matter; it contained fragments of pottery and of carbonised wood; the potsherds lay horizontally and were thickest at the bottom, growing rarer above until the top of the stratum was virtually clean. This is what one would expect with a swamp into which refuse was thrown – the heavier substances would sink to the bottom and lie flat in the muddy water. At level 1.00 m. the black mud gave place to a mixture of sand and grit, etc. lying in narrow streaks of black and grey and red and containing a certain amount of pottery; this was the surface of the dried marsh. Upon it rest the strata of human occupation which have already been described.

#### Pit G (Plates 1 and 72)

The pit was dug on the outskirts of the Royal Cemetery area, to the NW of the Royal Tomb PG/777.

At 14.50 m. above sea level there lay a pavement of burnt plano-convex bricks enclosed by the remains of walls of crude plano-convex bricks; associated with it were two terra-cotta ring drains; owing to the denudation of the site the pavement was only 2.20 m. below the modern surface. At 13.50 m. were found a painted clay animal figurine and part of a clay offering-vase, Type RC.16. At 12.00 m. there was a mud floor in which was set a clay pot, Type RC.79, ht. 0.65 m., diam. 0.70 m., and by it lay a mortar and a rubbing-stone. Below it was another mud floor and at 11.00 m. a third into and on which were built hearths of burnt bricks, plano-convex, measuring 0.23 m. x 0.125 m. x 0.055 m., others 0.215 m. x 0.10 m. x 0.08 m., perhaps old bricks re-used. Immediately below this floor came the coloured strata of the old rubbish-mounds, but at this point they ran horizontally, not on a slope. At 8.50 m. was found a clay vase with double mouth, U.12775, Fig. 12 bis, a. At 10.20 m. there was another floor together with a fragment of mud-brick wall; it is shown in the section, but was not really on the line of it; it serves however, to connect the floor with hearths with others further to the NE over the Cemetery area, implying that the site was terraced down hill. NE of the hearth floor we came on a mass of mud brickwork, very rough, clearly the

footings of a wall which had disappeared; they had been laid in a trench cut through the old rubbish and laid with a pronounced outward cant; the "wall" was a metre thick and built of bricks strongly plano-convex, 0.24 m. x 0.19 m. x 0.14 m. in the centre; it was very crooked.

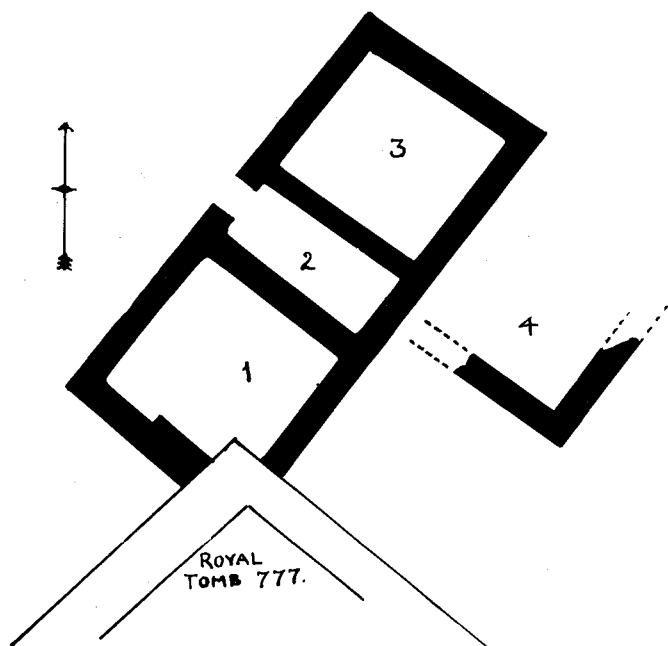

Fig. 12. Early Wall Remains in the Royal Cemetery Area. Scale  $\frac{1}{200}$ .

sometimes resting directly on the older, sometimes separated from it by a stratum of black rubbish, but the SW wall is of the later period only; the late SW wall is built with bricks on edge, the SE wall in herring-bone fashion. The bricks are plano-convex and measure 0.28 m. x 0.12 m.; those in the older building are flat and measure 0.28 m. x 0.24 m.

Extending from this neighbourhood in the direction of Queen Shub-ad's tomb (PG/800) were other walls giving no comprehensible plan but also belonging to two periods; the end of the upper wall seems to have been cut away by the shaft of Shub-ad's grave, it rested on the typical coloured rubbish strata; the older wall, which was immediately below this, had its foundations more than two metres lower and the stratified coloured rubbish came up against the sides of it; close to it and contemporary with it were two examples of the clay "mixing-bowl" RC.1.

Over a large part of the Cemetery area there extended walls of plano-convex mud brick, at two distinct levels; *v.* the section on Pl. 72. All were thin and flimsy, all much destroyed by the diggers of the Cemetery graves, and in no case other than that of the building just described close to Pit G was there enough of them left to constitute an even partial ground-plan. To the SE of the great Death-pit PG/1237

It had evidently been a retaining wall for a terrace; against its inner face and flush with the top of its remaining brickwork was a pavement or platform of four courses of mud bricks which could be traced SW for a distance of at least seven metres. Outside the wall (to the NE) the strata of the old rubbish-mounds ran horizontally for a short distance, but were then cut away by strata sloping down at an angle of 45 degrees; this is obviously the edge of the old terrace from which the wall rose to support a higher platform.

The general contours make it clear that this terrace must be more or less contemporary with house remains lying slightly lower down the slope between the royal tombs PG/777 and PG/580. The plan of these is simple (Fig. 12). Room 1: the SE side destroyed by the cutting of the shaft of PG/777; only foundations left. Room 2: the east corner destroyed by a rubbish (?) pit; apparently a true jamb denotes the presence of a door; walls from 2 to 5 courses high. Room 3: the SW wall rests on a stratum coloured rubbish, the NE wall has a wide footing set 2 courses deeper and in the east corner by the recess stands 5 courses high. Room 4: its connection with the rest of the building is uncertain; it shews two periods, the later wall

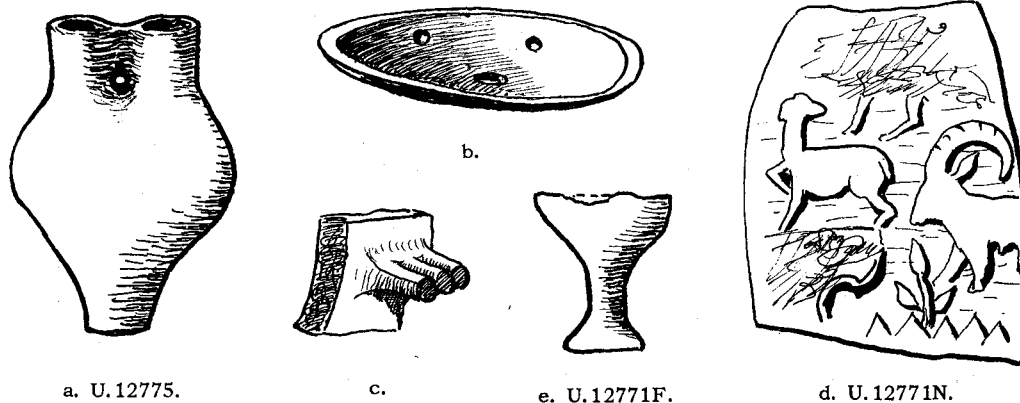

a. U.12775.

c.

e. U.12771F.

d. U.12771N.

Fig. 12 bis.

there remained the NW wall and part of the NE and SW walls of a room with a clay floor on which lay a deposit of ashes and inscribed archaic tablets; above them was a layer of ashes and pottery and on this was built a later wall following the lines of the old. The tablets ran right up to the wall-face and lay along it and were certainly contemporary with it. Below PG/1332 (*v.* the plan of the Royal Cemetery, Vol. II, Pl. 274) there were tablets found in a bed of black ashes which covered wall remains and might have been contemporary with them, but as the ash deposit was a continuation of the regular strata SIS 4-5 in pits W, etc., it was more likely that the walls were ruined before the rubbish was heaped above them and that they had no direct connection. At the very beginning therefore of the early dynastic period buildings of plano-convex mud bricks spread beyond the town limits as given by the heavy terrace wall in Pit G over the area part of which had been a cemetery in the Jamdat Nasr age; these may have been houses but possibly were merely store-rooms of a temporary nature. They were destroyed and a second series was built above their ruins, only to be destroyed in its turn when the rubbish forming the SIS 4-5 stratum was heaped on the site, i.e., at a time still very early in the period of the plano-convex brick builders: over this rubbish-heap a vast amount of debris had to accumulate before the first of the graves of the Royal Cemetery could be dug into it.

Returning to Pit G proper; just outside the face of the terrace wall and 1.80 m. below its foundations was found an inscribed tablet.

Inside the terrace wall and outside it the stratification was the same except that outside it the horizontal deposits gave place, as explained, to sloping lines; there were no more constructions, only debris.

Just below the 11.00 m. level there were found a fragment of a decorated steatite bowl, U.12768, Pl. 36, and part of a painted al 'Ubaid figurine, U.12770, Pl. 22; these clearly did not belong to the same horizon. At a slightly lower level, 10.50 m.-9.50 m., there were found a miniature white calcite bowl of type RC.112, diam. 0.028 m., part of a shallow diorite bowl, a basic diorite jar-cover (?) apparently cut down from a larger bowl (Fig. 12 *bis*, b), a miniature rectangular box of terra-cotta, 0.055 m. x 0.045 m. x 0.025 m., a miniature clay goblet 0.04 m. high, U.12771, F, Fig. 12 *bis*, e, a clay "rattle" and model wheel, a clay model of a curved metal (?) blade, cf. U.14938, Pl. 45, h, a clay ring, diam. 0.09 m., one of the very large clay cones for wall mosaic with a hollow at the end, cf. Pl. 15, two fragments of triple reeded clay vase-handles (Fig. 12 *bis*, c), a stone spindle-whorl, an oval pebble burnisher, a flint saw and several flint chips, and several small and very rough clay models of animals which continued also to the lower levels, a flint hoe and seal-impression Fig. 12 *bis*, d, U.12771, N. Outside the terrace wall at the 8.50 m. level painted potsherds began to appear, two with bands of dull red on the buff clay, several of al 'Ubaid type and one rim of a bowl or cup of drab clay on the inside but with an outer face of brilliantly burnished black. Inside the wall line, where the stratification was more dependable, painted pottery began only at the 8.50 m. level; between this and 7.50 m. there were found examples of reserved slip ware, plain plum-coloured red-painted ware, light ware with bands of dull red paint, Jamdat-Nasr 3-colour painted ware and al 'Ubaid ware; the only distinctive shapes that could be observed were plain cylindrical pots of rough ware, drab clay, about 0.40 m. high and diam. 0.06 m. With the potsherds were numerous jar-stoppers, a mud jar-sealing with rows of animals, a number of small rough animal figurines, U.12767, fragments of obsidian, a copper needle and a very long slender clay bead made in imitation of those of the core of the conch shell, U.12766, a clay "nail" and part of a clay sickle. Of the cylinder pots the lowest occurred at 7.70 m. Between 7.40 m. and 6.50 m. there were found half a dozen seal-impressions on clay, Nos. 138, 154, 326, 447, 480, 481, 482 and 483 of Vol. III in this series, and part of a small vase of grey ware with four lug handles and of a hand-made bowl with flat base and straight sides of brown clay finely burnished; reserved slip ware still occurred at this level and with it were examples of three-colour Jamdat Nasr ware, three pieces with red designs or bands painted on drab clay, one of the plain red Uruk ware and half a dozen fragments of al 'Ubaid pottery; other objects included a chip of obsidian and a fragment of an obsidian vase, three clay copies of the long cylindrical beads cut from the core of a shell, a fragment of a modelled terra-cotta figure of uncertain character.

For a study of the pottery types from this pit *v.* Frankfort in the *A.J.* IX (1929), p. 344.

## PIT H

A small pit was sunk through the middle of the floor of the central chamber (B) of the royal tomb PG/779 to a depth of 3.15 m. It gave the following results.

Immediately below the tomb floor, which lay 5.65 m. above sea level, was sand and rubbish, mixed, below which came a stratum of thick rubbish containing pottery fragments running at a sharp slope from SW to NE, this being the normal course of the strata of dumped rubbish into which the tomb shaft had been cut; below this was relatively clean sand the bottom of which was most irregular inasmuch as it overlay heaped rubbish. The highest point of this rubbish was at 1.25 m. beneath the tomb-floor where was a pile of black ashes mixed with broken brick; this rested (at 1.65 m. below the floor) on a bed of sand and grey rubbish



Fig. 13.

which although scooped out in the middle did extend over the whole area of our pit. From 2.10 m. to 2.35 m. down was coarse mixed rubbish with brick fragments and potsherds, including fragments of Type JN.25 and a sherd roughly incised after firing with a mark, thus Fig. 13. This stratum was absolutely horizontal. At 2.35 m. to 2.40 m. down was a very regular belt of deep black rubbish, then one of sandy soil containing some potsherds going down to 2.65 m. and then a stratified belt 0.25 m. thick of grey and sandy soil with lines of well-defined black above and below, and from 2.90 m. downwards (2.75 m. above sea level) sandy clay free from pottery or other impurities. Excavation stopped at 2.50 m. above sea level.

## PIT K (Plate 76)

This and Pit L were really two parts of the same excavation; the area marked out for digging proved to be divided into two by a heavy wall – one of the enclosing walls of the early Ziggurat terrace – and work was carried down on either side of this and separate notes were made of the two sections thus obtained.

Below the Neo-Babylonian pavement of the Nannar shrine there was mixed rubbish containing fragments of Larsa bricks; this went down to and rested on a laid filling of plano-convex mud bricks which covered all the chambers of the Archaic II Ziggurat terrace buildings. It was evident that the clearing of the site for the Neo-Babylonian reconstruction had been very thorough and had resulted in the complete destruction of all the earlier remains of the historic period. The mud-brick packing, containing quantities of al 'Ubaid potsherds stopped at level 10.10 m. and was succeeded by a stratum about 0.30 m. thick of mixed soil, sand and clay with fragments of broken bricks both baked and unbaked. At level 9.70 m. there was on the SE side of the pit a floor of white cement which had no definite edge but tailed off into a belt of clean sand; below this came brick earth with rubble and some al 'Ubaid potsherds, then alternate and very regular strata of clean sand and grey mud, these being particularly clear at levels 9.25 m., 9.10 m. and 8.40 m., with narrow but very distinct belts of the same two materials going down to level 8.25 m. and at level 8.20 m. a belt of stiff red clay, smooth on top and apparently a floor; this lay on a bed of clay containing a good deal of broken pottery and brick (thicker at the bottom of the stratum) which was not quite horizontal but sloped up to the north corner; here the bottom of the stratum came at level 8.05 m. whereas in the south corner it was at level 7.70 m. Down to level 6.70 m. there was a succession of narrow belts of clean yellow sand and grey soil alternately, with extremely little pottery; what there was was not al 'Ubaid ware but plain and wheel-made. The presence of the al 'Ubaid pottery in the upper strata must be due to the artificial raising of the terrace level and the use for this purpose of soil obtained by deep digging; this is manifestly true of the top stratum of plano-convex brick and can hardly fail to be true of the intermediate strata.

Between levels 6.70 m. and 5.90 m. there were definite remains of buildings. Running parallel to the SE side of our pit and about 2.00 m. from it was a line of grey mud-brick rubble 0.55 m. wide and 0.35 m. high with reddish brick clay on either side of it; further wall remains came rather lower down in the stratum, giving two sides of a rectangular enclosure; in the clay on either side, between levels 6.60 m. and 6.10 m., were quantities of small clay wall-cones, scattered, none of them approximately in position, together with disks of black shale having copper wire attachments behind. The "walls" were certainly no more than rubble foundations, and no single brick could be extracted to give measurements: at level 5.90 m. there were in the tumbled brickwork long timbers once apparently coated with bitumen lying in the direction of the supposed walls and by them and for some distance down there were lumps of bitumen which were obviously the crude masses collected from the bitumen springs and never melted down for use.<sup>1</sup> Judging by the level, these remains must be connected with the floor on the NW side of the Ziggurat on which also cones were found (*v. p.* 28) and the bricks must have been of the "Riemchen" type.

Below the walls was a belt about 0.40 m. thick of mixed rubbish and broken brick, then, from level 5.90 m. to 5.10 m., clean sand containing pottery. In the next 0.20 m. was a succession of some 15 narrow strata of grey, red and yellow, apparently all water-laid and as they ran off into each other and shewed no sign of any dried surface they were laid quickly and within a brief space of time. Then came a deep black stratum of ashes and broken pottery 0.10 m. thick, and from level 4.80 m. to level 4.30 m., more narrow bands of brown, red and grey, all water-laid and well-marked above but rather confused below; from this to level 3.50 m. was fairly uniform reddish sandy soil and below that again grey soil mixed with lumps of greenish clay. All the water-laid strata contained a certain amount of pottery, mostly small pieces; below them pottery was more common. Mixed soil with plentiful remains but no sign of buildings continued down to

<sup>1</sup>*V.* the analysis in Appendix VI, p. 157.



level 0.25 m. when the infiltration of water put a stop to the work.

It is obvious that the pottery from the upper strata of artificial filling above the level of decorative wall-cones (level 5.90 m.) can have no stratigraphical importance. From that level down to 4.20 m. (including a few fragments from the upper water-laid strata) the pottery was hand-made (except for one small cup-base which seemed to be made on the slow wheel) and of the al 'Ubaid type; small pieces of copper were found, sickle fragments, small wall-cones and one large hollow-ended clay wall-cone.

There were examples of plain red-wash wares and of wares with painted designs in red on a cream-coloured slip; nearly a third was of the normal al 'Ubaid ware with black paint on a greenish or buff ground; nearly all was of thick and coarse, and of the decorated pieces the vast majority had only plain horizontal bands of colour; much of the apparently plain ware may have belonged to painted pots, but there were three examples of plain red clay, smooth but not burnished, some of plain red clay with creamy slip, and there were rough wares either of a clay greenish-white all through or of a light pinkish drab clay with a creamy surface due not to the use of slip but to the effect of heat on a water-smoothed body. Few shapes could be determined; there were rough bowls of Type JN.2 (but without the cut rim) and amongst the painted vessels examples of Types aU.2 and 8; one of the former had combing on its inner surface and was extremely hard fired. The decorative motives were few, for the most part mere bands of black paint on thick coarse ware; but with them were the patterns 41, 42, 43 and 44 on Pl. 46. One fragment had a large horizontal lug, not pierced.

In order to avoid any risk of confusing the levels and also in order to accentuate the differences in the pottery that might mark the different strata a gap was left between the strata selected for study; thus the remarks above apply to levels 5.70 m. to c. 4.00 m.; the next apply to level 2.70 m. to 1.70 m. Between 2.70 m. and 1.70 m. there were found several small thin clay wall-cones, large nails (wall-cones?) of baked clay with a flat head diam. 0.09 m., two or three bent clay "nails" with rounded heads, a clay disk with two holes through it, a number of small clay spindle-whorls, two clay stemmed disks, probably ear-studs, cf. Pl. 15, U.2806A, but they were both broken and judging from another specimen found (Pl. 15, U.17985) which was painted, they may have been decorative cones; a small ball of bitumen and a fragment of clay wall inlay, perhaps a flower, perhaps a figure, flat and silhouetted, with a cone-shaped protuberance behind for fixing it to the wall; there was also the sharply-pointed base of a little cone-shaped pot in rough clay which recalls the *cornets* of Susa I, but may be simply a wall-cone, and with this fragments of clay sickles, and fragments of baked clay bars round in section (diam. from 0.025 m. to 0.03 m.) straight or slightly curved, of uncertain use.

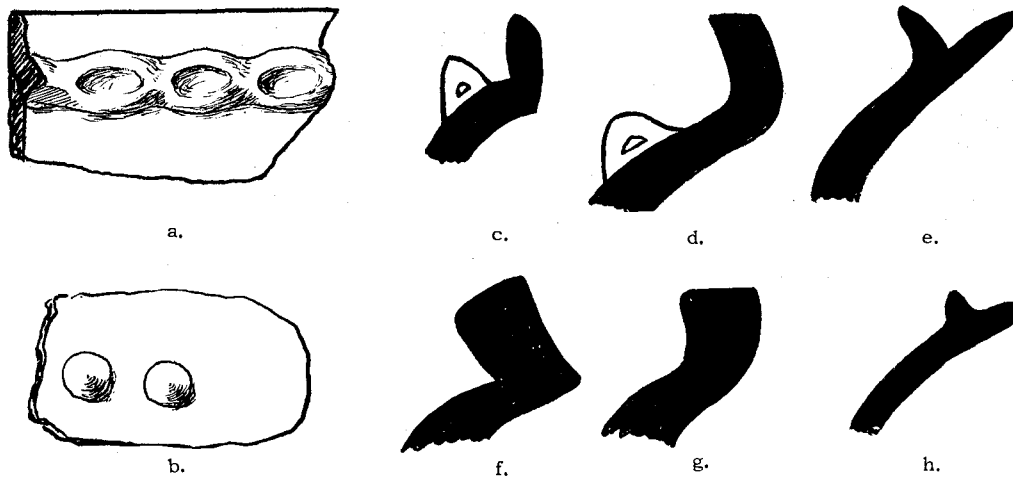

Fig. 14.

Of the plain pottery the vast bulk are of the light creamy-white clay with a greenish tinge which is characteristic of al 'Ubaid; on the finer wares the surface is sometimes due to water-smoothing, sometimes to a definite slip which is applied also to a body of reddish clay; there are a few examples of red or reddish-drab ware with natural surface. There were fragments of "mortaria" with combed or scabbled inner surfaces; one fragment of a very large bowl, straight-sided, of greenish clay had a raised band with thumb-mark decoration (Fig. 14,a), one had small breast-like knobs arranged in pairs (Fig. 14,b), one had impressed horizontal lines like string-lines which were certainly ornamental, one very large pot had had a thick loop handle; there were several jars with horizontally-pierced lugs near the rim and others with a raised ridge for the fitting of a lid and in it vertical holes for the strings with which the lid was secured. Of shapes there were recognisable aU.4, 23, 24, 38, 53, 54 and the rims shown in Fig. 14,c-h.

One fragment of coarse reddish ware had a complete coat of plum-coloured paint; the rest of the decorated ware (which outnumbered the plain fragments) was of the normal al 'Ubaid type. Apart from the

simple decoration of horizontal bands, straight or waved, or straight and waved combined, cross-hatching, etc., the fragments shewed the motives on Pl. 46, nos. 1-27 and 37.

Much of the painted ware was quite thick, but there was a fair proportion of the fine ware including examples of "egg-shell." In most cases the design was in black paint on a drab or greenish ground, but there was a good proportion with red or red-brown paint usually on a creamy slip laid over a reddish-drab body clay. One piece (Pl. 46, no. 21) had its design in black on cream and the part of the surface preserved below the pattern was light red, but this seemed to be a case of the flaring of the clay in the kiln rather than of deliberate three-colour painting. The general effect of the decoration at this level was rich, with a tendency to all-over design.

Level 1.70 m. to 1.00 m. It was probably due to accident that the painted fragments found in this stratum were fewer in proportion and in themselves less remarkable than in the stratum above. The plain pottery was identical with that from stratum 2.70 m. to 1.70 m; there was a large proportion of very coarse and clumsy wares (sometimes with bands of black paint); coarse vessels might be of plain light brick-red clay, bowls of the same clay would have a creamy slip on the inside; one tubular spout occurred and one handle (form uncertain); jars with horizontally-pierced lugs were not uncommon, also jars with rim ridges vertically pierced for the attachment of the lid; one plain fragment had applied knobs in relief. Recognisable shapes were aU.4, 16, 21, 54.

Of the painted wares red-brown design on a creamy slip was fairly common, as well as red-brown on natural pinkish clay; there were one or two examples apparently of a red plum-coloured wash over the whole pot and of over-all painting in black (one plate had the rosette-motive, Pl. 46, no. 1, on the outside and was painted black all over on the inside); there were a few pieces of "egg-shell" ware. The tendency of the design to cover the entire surface was evident. The ornamental motives recorded were as follows, Pl. 46, nos. 1, 2, 3, 9, 13, 28-36, together with one example of what seemed to be a very large and bold floral pattern, resembling Fig. 11, h. There were also clay sickles, clay rods as in the stratum above, and a square of limestone inlay, plain.

Stratum below level 1.00 m. The plain pottery was identical with that from the higher strata, the only novelty being a fragment from a rough bowl of light brick-red clay with criss-cross lines deeply scored on the inner face and filled with bitumen; the ledge-rimmed jar with vertical holes for strings, as well as jars with applied knobs vertically pierced for the same purpose (aU.38) occurred; the flat-based straight-sided bowl (aU.51) appeared both in coarse and in fine wares—the outstanding example of it was the painted bowl U.17149, Pl. 46, no. 45; one such had its walls vertically trimmed on the outside with a wooden smoother. The ornamental motives included nos. 1, 2, 9, 17, 30, 33, on Pl. 46, (the last on a fragment having a curiously lustrous surface) and nos. 37-40, 45 and 46. Most of the designs were in black on greenish drab but red-brown paint on a creamy slip was fairly common, there was one example of over-all plum-coloured red paint and many of over-all black. A few pieces of "egg-shell" ware were found; of these one was most important, the body of pinkish cream on which a diaper pattern (no. 39) in lustrous orange paint enclosed by bands of lustrous black (a second fragment of orange diaper pattern may have belonged to the same vase); this is the only example from Ur of this ware, which is that commonly found at Arpachiyah.<sup>1</sup>

With the pottery were found bent clay "nails," clay sickles, more of the clay rods found in the higher strata, one of them 0.17 m. long with one rounded and one broken end, and a fragment of a coarse conical pot with a small hole in its base (as if moulded round a stick) which may have been a large *cornet*.

#### PIT L (Plate 76)

The pit, dug between two walls of the early Ziggurat terrace buildings was in its general features a repetition of Pit K dug on the other side of the inner wall. The packed filling of mud brick was here lacking and mixed rubbish of late (Larsa) date came down as low as the top of the inner wall and crossing this lay heaped against the outer wall's face; below this was sand, wind-blown, denoting a period of desolation and neglect, then mixed soil containing al'Ubaid pottery fragments going down to the level 9.50 m.; stratified bands of black rubbish and lighter material occupied the next half metre and then came mixed soil and sand ending at level 8.15 m. Between levels 8.15 m. and 7.60 m. there was the stratum of heavy red clay, smooth on top, which had been encountered in Pit K at the same point; below it, running slightly uphill to the NW, was a belt for the most part of light sand highly stratified; between 7.30 m. and 7.20 m. was a double belt, strongly marked, of deep brown colour and between 7.00 m. and 6.70 m. thin bands alternately light and dark; the dark predominated in the lower part of the stratum, which ended at level

<sup>1</sup>Mallowan, in *Iraq*, Vol. II (April, 1935).

5.75 m. in a bed of black ash resting on a definite floor of beaten clay covered with a coating of white lime. Below the floor, at level 5.70 m. was another belt of black ash containing pottery and fragments of brick and two large hollow-ended clay wall-cones diam. 0.06 m. and rather more than 0.18 m. in length; below this was red soil going down to level 3.80 m.; it was for the most part peculiarly clean, but between 5.70 m. and 5.20 m. it was darker in colour and contained a fair amount of pottery, another (broken) wall-cone of the large hollow-ended type and part of a cement brick measuring ? x 0.085 m. x 0.05 m.; probably this was of similar dimensions to one found in this same pit at level 9.70 m., obviously out of its true horizon, which measured 0.20 m. x 0.09 m. x 0.055 m., flat and rectangular. The pottery below the white floor and down to level 3.80 m. was very mixed; much of it was wheel-made and included examples of the rough bowl Type JN.2 with knife-trimmed edge, plain wares in red and drab clay, a few sherds of plain all-over red-painted ware, one specimen of Jamdat Nasr 3-coloured pottery and quantities of al 'Ubaid ware both plain and painted.

From level 3.80 m. downwards the soil was of a more grey colour, mixed but not clearly stratified. At 3.25 m. were found a mace-head of white limestone, U.17114, and a strip of worked gold, U.16981. From 1.40 m. to 1.10 m. was a band of very mixed soil containing great quantities of pottery, burnt ash, etc. The pottery (mostly from this burnt band) was much the same as in the corresponding stratum in Pit K, with certain fresh decorative motives, Pl. 46, nos. 47 to 51, of which no. 47 occurs on a large vase, no. 48 on a bowl, the design black on greenish drab clay, no. 49 on a large vessel of thick pottery with design in brown paint on drab clay, no. 50 on a ledge-rim jar and no. 51, in black on green, on a cup of Type aU.21. One fragment gave part of a handle, form uncertain; with the pottery were clay sickles, bent "nails," and such clay rods as were found in Pit K; these are generally slightly bent, have rounded ends and sometimes have small knobs on one side.

From 1.10 m. to 0.70 m. was clean sandy clay and then a streak varying in thickness from 0.01 m. to 0.06 m. of pitch-black spongy matter which seemed to be due to the decay of vegetation; it rested on a belt 0.20 m. thick of clay clean in itself but containing scattered lumps of the same black substance, possibly lumps of wood; below this again came soil full of pockets containing masses of the same black substance, lumps of clay burnt black or red, and some potsherds of al 'Ubaid type; the whole soil was water-logged and at a general level of 0.20 m. work had to be stopped, but the pockets were followed down for another ten centimetres and probably do continue further.

#### PIT W (Plate 77)

The pit was sunk from the level of the bottom of the Royal Cemetery close to the NE side of the royal tomb PG/1631; the upper levels which had been cut away in the excavation of the cemetery need not concern us, as they are virtually identical with the upper levels shewn in the section of Pit Z, Pl. 82. Here we started with the stratum of burnt earth, decomposed brick, lime and clay jar-stoppers known to us previously as SIS 4-5; below this came mixed rubbish and then two more seal-impression bearing strata labelled SIS 6-7. The distinctions were not sharply defined; the field-notes remark that "it was rather a case of a gradual change than of two layers (SIS 4-5 and SIS 6-7 respectively) separated by a distinct break; but SIS 6-7 represent at least the bottom of the seal-impression bearing strata." In other ways the contents of the two layers were sufficiently different to deserve the distinction.

In SIS 4-5 there were found - (a) model chariots in clay; wheels (cf. Pl. 16) and the bodies of cars, generally with high fronts, pierced in front for the pole and laterally (or through an axle-box below the body) for the axle; all were two-wheeled, *v.* Pl. 24; (b) clay spindle-whorls; (c) flat clay roundels, diam. c. 0.003 m. of uncertain use; (d) clay disks diam. 0.05 m.-0.08 m., with a hole through the centre diam. up to 0.03 m.; (e) clay balls, probably missiles, diam. c. 0.045 m.; (f) clay sling-bolts; (g) clay bent "nails," a few fragments only; (h) clay cones for wall mosaic, mostly of the large sort l. 0.12 m.-0.14 m., diam. 0.03 m., but a few of the slender sort, l. 0.06 m., diam. 0.01 m.-0.015 m.; (i) one clay cone with convex sides, ht. 0.04 m., diam. 0.055 m.; (j) very small cones of dark clay slightly hollowed out below and with the top pinched out and bent over almost in the shape of a human face, Fig. 15,a; (k) crudely hand-modelled clay figurines of men and animals, *e.g.*, U.18415-17 and 18423, Pl. 21; (l) rarely in the upper part of the stratum and more commonly in the lower part of it, clay roundels, *v.* Pl. 16, U.13749; (m) stone drill-heads for hollowing out stone vases, Fig. 15,b; *v.* p. 14; cf. also Pl. 13, U.16405; one of these occurred fairly low in the stratum and at its bottom they were common; (n) stone bowls, mostly of limestone but occasionally of basic diorite, Types JN.10, 17, 18, 25; they came only in the very bottom of the stratum. In the very lowest level also was found a brick (it was lightly baked, red all through but soft and crumbling, and the burning was probably accidental) measuring 0.195 m. x 0.11 m. with a thickness of 0.05 m. at the edges increasing at the centre to a maximum of 0.075 m.; it was therefore of the slightly plano-convex type; in the top of the brick, 0.05 m. from one end, there was a small hole obviously made by a thin stick which

had been driven slantwise into the soft clay, pointing towards the centre.

In stratum SIS 6-7 there re-appeared practically all the types of objects found in SIS 4-5, and in addition to those (a) part of a fairly large clay model of a boat with high stem; (b) clay objects like wheel-hubs, the flange generally chipped but looking as if it had either been much wider or had had spokes radiating from it; average diam. 0.09 m., *v.* Fig. 15,c; (c) a fragment of a clay model axe, Fig. 15,d; (d) a clay head of an animal, rather unusual type, Fig. 15,e; (e) pot-lid (?) of basic diorite, diam. 0.075 m.;

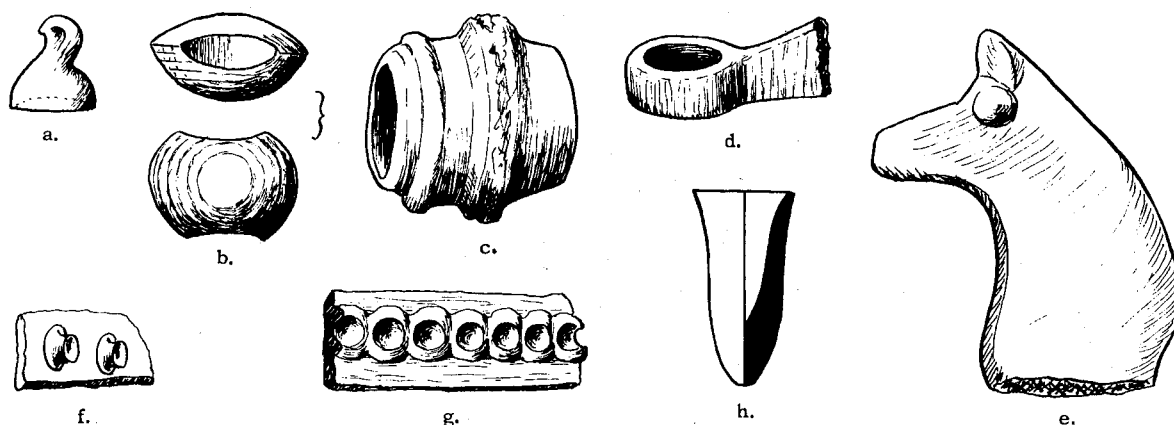

Fig. 15.

(f) fragments of shell tubular beads 1. *c.* 0.13 m., diam. *c.* 0.007 m. (g) a copper fish-hook, and two plain copper pins. As regards the pottery, twisted loop handles from large jars were fairly plentiful; they had never occurred in SIS 4-5 and actually did not occur either in the Jamdat Nasr graves of the lower stratum or in the soil in which those graves were dug; on the evidence of this particular excavation they were peculiar to the one period represented by stratum SIS 6-7. There were several examples of pots with two knobs projecting side by side, perhaps attachments of loop handles made of string (Fig. 15,f); the plain vessel Type JN.104 with its upstanding lug and band of thumb-pressed decoration also makes its first appearance here; there was one curious hollow ledge handle made by pressing out the wall of the vessel from the inside, one instance of decoration by strips of clay applied to the surface of the pot and pressed down with a series of overlapping finger-tip impressions (Fig. 15,g); a few fragmentary examples of grey smother-kiln pottery with horizontal or vertical pebble-burnish lines, and one piece of drab ware covered with an unburnished plum-red wash. The pottery Type RC.1 was common to this and to the stratum SIS 4-5 and continued into the Jamdat Nasr grave stratum; a tall cup of coarse drab clay, Fig. 15,h, was found here; examples of Types JN.77, 146 seemed to belong not to this but to the lower stratum.

As can be seen on the section, Pl. 77, the stratification down to the bottom of SIS 6-7 is undisturbed, the layers running unbroken across the area excavated; they slope fairly sharply from SW to NE, following the contour of the older rubbish beneath: owing to this slope it is impossible to give the exact level above the sea at which the various strata succeed each other, but it will be seen that at the SW end the bottom of SIS 7 comes at about 6.80 m. above sea level; towards the NE end it tails off and as such disappears, strata of a different composition and less well defined taking its place and sloping at the same angle. Here the stratification had been to some extent disturbed by the digging of shafts for graves which lay either in or just below what corresponded to the SIS 6-7 strata; they were later in date than the Jamdat Nasr graves and were necessarily either more or less contemporary with or positively later than the strata in question, which must have been deposited before the shafts could be dug into them. All the graves in the SW half of the excavation (the right hand side of the section) and the lower graves in the NE half were dug before the SIS 7 stratum was formed and are necessarily older than it. At (roughly speaking) level 6.00 m. the soil was still largely composed of potsherds, as in the SIS 6-7 stratum above, but fragments of stone vases began to appear more commonly; then, more especially at the NE end of the pit, there occurred bowls of rough pottery, Type JN.4 and Type JN.8, the latter about 0.23 m. deep and 0.60 m. in diameter, set upright or inverted in the ground; they were associated with the graves which were found immediately below. In the soil disturbed by the grave-shafts were clay pots of Types JN.3, 9, 36, examples of the clay rattles or tops (Fig. 16,a) and of the hub-like objects already described; a clay model of an axe, numbers of clay vase-handles of the rope pattern, and an obsidian pin.

The upper graves were in bad condition, the clay vessels being for the most part crushed and the human remains so decayed as to be scarcely recognisable; the soil, especially at the NE end of the pit, was full of broken pottery. As we dug lower the soil grew cleaner and the graves were in better state; the lowest graves were cut down into a belt of very clean uniform water-laid sandy clay which was evidently the familiar flood deposit. Exactly where the top surface of the silt had been it was impossible to

say, for it had been disturbed by the close-lying graves; its under surface, which was easily traced, was also irregular and came at about level 1.50 m.; the undisturbed belt was just over a metre thick. Near the centre of the pit the silt was piled over a mound of earlier rubbish; the potsherds found in this and in the pre-flood stratum generally were uniformly of al 'Ubaid type; amongst them were fragments of Type aU.41, and a complete painted bowl, Type aU.20. The pre-flood stratum sloped very slightly from SW to NE and was thicker against the NE side of our pit; here it contained some bands of a darker colour, dirty soil contrasting with the clean texture of the regular deposit, but these too were water-laid and so far as could be seen horizontal; they were obviously due to currents bringing down refuse from the town site over which the water was passing and they seemed to support the theory of the silt stratum being formed against an obstruction such as would be offered by the original town mound.

Immediately above the undisturbed part of the silt deposit was found part of a terra-cotta painted figurine of the al 'Ubaid type (Pl. 22, U.18527). An adze of polished green stone found in the silt had evidently been dropped on it while it was wet and soft and had sunk of its own weight, for the heavy end was downmost and the mud above shewed no sign of disturbance.

Immediately below the silt there were found seven clay roundels pierced with two holes, like those found in Pit F, *v.* p. 8, touching each other, with an eighth close by; another set of four lay 0.30 m. below the silt near the SW side of our pit: with the latter was the complete painted bowl, Pl. 18, U.18624, and near the former were some shell beads—natural shells pierced for stringing.

In these occupation levels there was found a jaw-bone of an ass, 0.55 m. below the silt, and a second lay 0.25 m. below it (1.60 m. above sea level); at the same level as the latter were the remains of a large pot of rough yellow clay containing some animal bones, a single vertebra of a fish and some ashes.

Layers of mud and silt continued down to sea level and just below that came the stiff green clay which represents the bottom of the old marsh. The section is in entire agreement with that of Pit F.

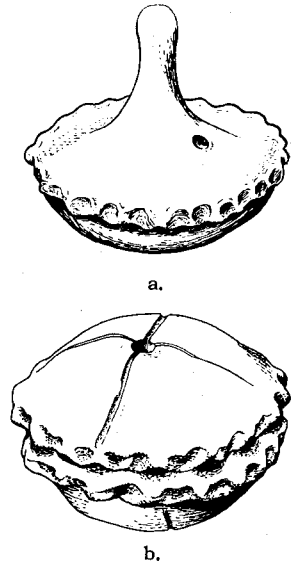

Fig. 16.  
Two Types of Rattle.

#### PIT X (Plates 79-81)

The pit, dug in 1933-4, was just outside the SE wall of the Neo-Babylonian Temenos. Immediately below the modern surface there was found the ruin of a large mud-brick building contemporary with that Temenos. It was built of bricks 0.32-34 m. sq. and 0.11-12 m. thick; the outer NW wall, heavy and buttressed, ran parallel with the line of the Temenos but at a higher level, the ground sloping down from it to the Temenos wall: what remained of the return wall at the east corner had its foundations stepped up sharply, and the inner walls lay considerably higher; the outer wall therefore had acted as a retaining-wall for a raised terrace on which the building proper had stood. The ruins, badly preserved, had suffered from intrusive burials of Persian date, of which a few were found undisturbed.

The terrace was formed of rubbish which was quite obviously a packing brought expressly to level the terrace; below the wall foundations there was a mass of very light rubbish, ashes and broken pottery the stratification of which, though not well marked, shewed that we were dealing with a normal rubbish-heap which had accumulated gradually in front of a row of houses which ran along the SW side of the pit. The houses gave evidence of several re-buildings and alterations but in the main there were two periods represented, defined by floor levels of which the higher was about 1.50 m. above the lower; graves under the lower floor contained pottery characteristic of the Kassite age. Towards the middle of the pit's area, directly under the NW wall of the terrace building, was a rectangular shed with flimsy walls of mud bricks 0.32 m. sq. by 0.10 m. thick; only two courses remained of which the lower had its bricks set upright on edge; inside was a mud floor laid over a packing of mud bricks, and into this at the NE end were let two clay store-jars. The shed was, judging by its level, contemporary with the lower houses. In the middle of the space were two ring drains. One could quite well have belonged to the Neo-Babylonian terrace building, the other came directly under an interior wall of that building and therefore was necessarily older than it, but came too high to have served a building of the date of the upper Kassite houses; it therefore represented a building intermediate in date between the two, of which no walls remained. We have therefore evidence of four building periods earlier than the Persian graves which themselves must have been under houses now denuded away.

Below the level of the house foundations was the normal rubbish of the mounds which extend over the whole of the cemetery area; the original stratification had been obliterated by the digging of grave-shafts but in the higher levels enough remained to explain a point which had always puzzled us. It had seemed strange that a large area inside the city walls and close to the Temenos should throughout most of the town's history have been unoccupied by buildings and given over to mere rubbish-heaps. In the present case the gently-sloping strata resulting from the dumping of refuse were at different places and at different levels cut back so as to give vertical faces below which the hollows had again been filled in with rubbish of another character; in short, the area had been used as a quarry as well as a dumping-ground. When in the town a new building had to be constructed on the site of an old, it was the general custom to raise its level; the debris of the upper part of the old walls might furnish all the material required, but if a regular terrace was desired ballast had to be imported from elsewhere,<sup>1</sup> and in that case the contractors found in the town rubbish-heaps a supply ready to their hand; the mounds might be dug away almost as quickly as they were formed. It is worth noting that the rubbish of the mounds includes virtually nothing that can be recognised as organic matter—there are, for instance, no animal bones such as would be encountered in a kitchen midden, only fragments of bricks, decomposed mud bricks and broken pottery; the dump would therefore have been unsightly but not insanitary. Where transport through the narrow streets was difficult the convenience of having the mounds in the middle of the city is obvious; that they would not offend the oriental sense of the fitness of things can be argued from modern parallels, e.g., at Aleppo, where extensive rubbish-dumps occupied an important site immediately adjoining the Citadel moat.

The constant removal of rubbish would explain the comparative nearness to the Kassite level of the Sargonid cemetery. This occupied a belt of soil four to five metres thick which, following the mound contours, sloped from a point 16.50 m. above sea level at the NW end of our pit to 11.50 m. at the SE end.

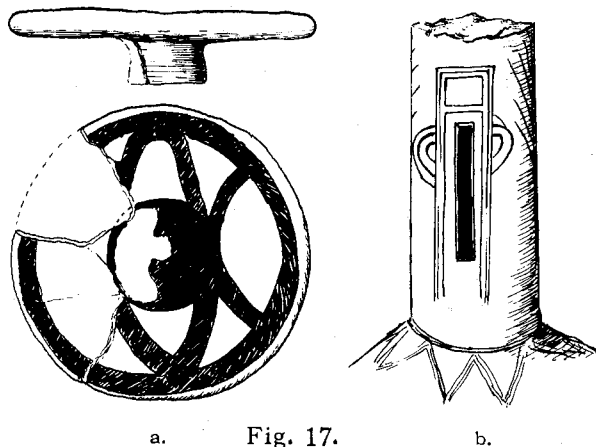

a. Fig. 17.

b.

The graves are described in detail in Appendix III. One object found amongst the graves but not obviously connected with any one of them calls for description: it was a model chariot of unusually large size made of unbaked clay covered with a white lime wash on which were patterns painted in black; it was in lamentable condition and could not be preserved. The body of the car was rectangular with an axle-socket below its floor; the wheels, of which there had been two only, were 0.10 m. in diameter with boldly projecting hubs on the inside giving between the flanges a width of 0.12 m.; to the car there were attached four animals harnessed abreast: a drawing of the one wheel that could be reconstructed is shown on Fig. 17, a.

Another object also found loose in the soil was the lower part of a clay offering-table with incised decoration of a more elaborate sort than usual; two rectangular slits in the stem were treated as doors whose jambs boast the ring-attachments peculiar to shrines and between the doors are trees or palm-branches, Fig. 17, b. Here too was found a fragment of a type of pottery rare at Ur but well represented at Tello in the Gudea period; it is of a brownish-black clay smooth and fat in texture, highly burnished and decorated with incised designs, the lines filled with white paste (U.18860, Fig. 18, a). The miniature vase U.18855, Fig. 18, b, was found in the same stratum.

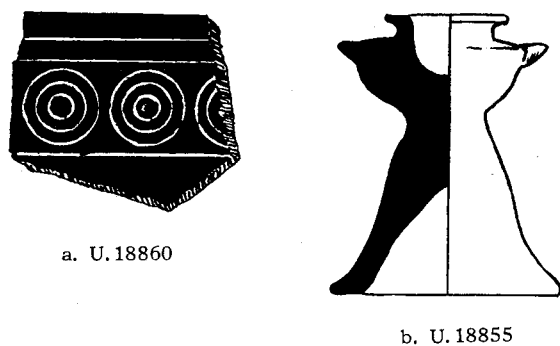

a. U.18860

b. U.18855

Fig. 18.

The graves of the Royal Cemetery period lying below the Sargonid cemetery were more numerous than I had expected and extended much further to the SE than was the case to the NE of our present excavation; they seemed to form an outlying annex of the main cemetery. None of them were rich; even the women's graves, which formed a small minority of the whole, contained very few gold ornaments and those of very little importance; the stone vessels were for the most part of poor quality and many of them had been broken and rivetted. What was peculiar was the large proportion of weapons, spears, axes, adzes and knives or daggers, which were far more common than

<sup>1</sup>A good example of this is the great courtyard of Nannar of which the floor-level was raised more than two metres by Nebuchadnezzar; some of the ballast used had been excavated from a considerable depth and was full of al 'Ubaid potsherds.

they had been in the main cemetery; most of the people buried here had been soldiers, and in view of their numbers it was reasonable to regard this as the military graveyard of the Royal Cemetery age.

Below the Royal Cemetery graves, at the SW end of the pit, came the familiar stratum SIS 4-5 with its usual collection of seal-impressions and archaic tablets;<sup>1</sup> here the stratum was not very thick and towards the NE it soon tailed off and disappeared altogether; the fringe of it was hard to follow and seemed to have been disturbed either by the digging of the later graves found by us in the next stratum or by the plundering of those graves.

The graves of the "Jamdat Nasr" cemetery were dug partly in rubbish which contained a good deal of al'Ubaid pottery, the proportion of this increasing in the lower levels, and partly in the upper part of the deposit of clean silt left by the Flood. The contents of the graves are recorded in Appendix III; many of the upper graves were associated with clay bowls inverted over them in the soil (*v.* Pl. 9, a, b), originally placed in the filling of the grave-shaft; one, not recorded in the Appendix, for it contained no furniture other than a single copper bowl, was curious for the attitude of the body. The skeleton, that of a man, was of unusual height, measuring 1.90 m. from the top of the skull to the heels, and lay on its back, fully extended, with the legs straight and the left arm only flexed at the elbow, the right arm by the side of the body; it is possible that we have here a survival of the al'Ubaid burial custom. Two al'Ubaid graves were found at the lowest level, belonging to al'Ubaid II; they were probably stray burials like that in Pit Z and certainly do not imply that the area was in continuous use as a graveyard from the al'Ubaid II period into that of Jamdat Nasr; for the cemetery they have no chronological importance.

Towards the east corner of the area at level 4.00 m. there was found, in no obvious relation to any grave, a collection of very small thin and narrow flint flakes, egg-shaped stone pounders, flint cores, large pebbles, shells and bits of shell, fragments of copper, fragments of mother-of-pearl inlay squares, fragments of stone vases, lumps of red haematitic paint and the lower part of a vase of red clay full of small flint chips; it was perhaps the stock-in-trade of a bead-maker or craftsman of a similar sort. The gaming die, U.18850, Fig. 7, b, was found low down, loose in the soil.

The original upper surface of the Flood deposit had everywhere been disturbed by the graves; the highest point reached by the undisturbed silt was just below the 3.00 m. level and trial-pits shewed that it went down to level 1.50 m.; below this came a belt of black organic soil manifestly due to the decay of vegetable matter, (*v.* Pl. 8, c), and this in turn rested on clean stiff clay containing the marks of plant roots; the surface of which was at 0.70 m. above sea level.

## PIT Z

At the SW of the Cemetery excavation two pits Y and Z were dug in 1929-30 from the grave level to below sea level; the two pits were separated by an unexcavated patch 16.00 m. wide. In 1932-3 another pit (W) was dug which virtually filled up this gap but was not on the same line, being a few metres to the NE of the first two. In 1933-4 a fresh pit (X) to the SE, its axis half-way between those of the pits dug in the two earlier seasons but to all intents and purposes prolonging their line. The sections published on Pl. 82 contain so much detail that a short description will suffice. The 1929-30 pit at the NE end of the line, Pit Z, gave the following results: —

The upper levels containing graves of the Royal Cemetery age had been dug away by us in 1926; in them there was no stratification, owing to the disturbance of the soil by the grave-diggers, and our work had always stopped short at a stratum — the first recognisable as such — of red burnt brick earth and broken brick, pottery, etc. This is SIS 4-5, the stratum rich in clay jar-stoppers with archaic seal-impressions (*Ur Excavations*, Vol. III) which underlies much of the cemetery and is invaluable as giving a *terminus post quem* for the graves (*v.* *Ur Excavations*, Vol. II., p. 222). Below this the strata, sloping sharply down with the fall of the rubbish as dumped here from the town, are remarkable well defined. A band of light earth, one of dark soil, a grey belt containing much lime, light earth, dark again and light succeed one another; then comes a belt of red burnt earth containing seal impressions and pottery and a lime belt also rich in seal-impressions and broken sherds, labelled on the section as SIS 6; a heavy bed of black mixed rubbish in the upper part especially of which there were more seal-impressions is SIS 7. Another layer of burnt earth separated this from the next rubbish-mass which thanks to the presence of a liberal admixture of burnt matter was itself rather red in colour; it contained a very few seal-impressions (SIS 8) but was really distinguished by the common occurrence of clay goblets of the peculiar type JN.25 which were not normally found above this stratum or below it; at the same level were found (in a black streak running through the red) part of a "mixing bowl" of rough clay, Type RC.1, a clay disk with a hole towards one

<sup>1</sup>Published in Vol. III of this series, and in Vol. II (*Archaic Texts*) of the Texts series.

edge, a rough clay figurine of an animal, part of a limestone bowl, Type JN.11, and a rubbing-stone; at 7.50 m. was a clay goblet of Type JN.25. Below the red came a thick muddy stratum, rather clayey sand mixed with dirt, grey above, then with a bed of blackish colour and grey again below; this soil was definitely disturbed by the digging of graves. The red stratum did not shew such evident signs of disturbance, but owing to its composition a hole made in it and filled up with the same material would have been very difficult to detect; the fact that none of the red material had found its way into the graves was evidence for the latter having been dug before the red stratum formed above them. The pottery here included examples of 3-colour Jamdat Nasr ware, spouted fragments and light wares with bands of dull red paint; at 4.00 m. above sea level the al 'Ubaid fragments began and grew more numerous as we went down. Here, between 4.00 m. and 2.80 m., were five graves of the Jamdat Nasr period or slightly later (see Appendix, PG/368, 369); in the same mixed stratum at 1.50 m. was a single grave of the al 'Ubaid period containing an unusually fine painted pot (Grave XX, *v.* p. 102 and Pl. 19, U.14988). At the bottom of the mixed rubbish was a line of broken bits of burnt bricks (flat types) resting on a stratum composed of fine alternate layers of clean bluish clay and sooty-black mud, the latter possibly due to the exposure of the clay as a temporary surface; 31 such layers were counted; in the mud there were many shells but very few fragments of pottery, these seeming to have worked their way down from above. Below this were two strata of blue clay separated by a very thin layer of fine brownish clay homogeneous in texture but strikingly different in colour; in the lower blue belt there could be distinguished the leaves of water-plants and part of the trunk of a tree which seemed to be a willow. Below this came a band of yellow clay in which were brown fibrous markings as of the decayed roots of plants; then, just above and extending below sea level, came green sand; when wet this was adhesive and clayey, but on drying it turned out to be a light green sand very fine in grain.

#### THE SITE EH (Plates 70-71)

The high mound in the south corner of the Neo-Babylonian Temenos was not included in the smaller Temenos of the Third Dynasty (*v.* the plan on Pl. 1) but lay outside it and was part of the oldest residential quarter. It had been excavated by Taylor, who called it the "Tomb Mound" owing to the great number of graves found in it:<sup>1</sup> it was excavated by us in 1925-6. We were principally concerned with the remains of the historic periods, but these lay very close to the modern surface and at various points we dug down into the underlying levels and came on the ruins of buildings constructed with plano-convex mud bricks. The buildings were not of great importance in themselves and the excavation was not carried far enough to produce consistent ground-plans; moreover the denudation of the site had seriously affected the remains, the higher walls that were traced always running out and disappearing as they came to the surface of the present slope, and the Third Dynasty foundations and graves, and Taylor's digging, had gone far to complete the destruction; our work was confined to a series of pits sunk between the walls of the Third Dynasty and Larsa periods and the earlier remains therefore appear even more disconnected than they probably were in fact. The plan of the Third Dynasty and earlier remains and the section on Pl. 71 will explain what was actually found.

In Squares P-U 7,8 and 9, immediately below the foundations of a temple of Nimin-tabba built by Dungi were walls of plano-convex mud bricks 0.23 m. x 0.135 m; a heavily-buttressed wall in Squares R, S and T 9 was the outer (NE) wall of a building of which the interior had been destroyed by the Temenos wall of Nebuchadnezzar; it stood to a height of 1.10 m. but was cut away at the SE by a trench of Taylor's; patches of plano-convex brick paving in Squares O 9 and P 9 on the line of the wall might be evidence for its having run so far. In Squares P 8 and Q 8 there were two intersecting walls aligned with the buttressed wall but not connected with it, and at the same level; the rooms which they had helped to enclose were floored with a bed of fine hard red clay; under this floor in Sq. R 9 was found a shell amulet in the form of a reclining bull, in the regular First Dynasty style (U.6478, Pl. 27) and in Square M 9, at about the same level (but the clay floor no longer ran at this point) was another amulet U.6486, Pl. 28, The pottery fragments were consistent with a First Dynasty date, and the building could safely be attributed to that period. In spite of the very fragmentary nature of the remains it became evident that over the whole site there had existed buildings whose floors were on the level of the clay floor in Squares P, Q and R 7-9; these were apparently the latest buildings of the plano-convex brick period. Their present condition is well illustrated by the photograph on Pl. 11,b; there remained a fairly complete terra-cotta bath together with its out-flow pipe; but of the building to which the bath belonged there were left only a few lumps of limestone rubble from the foundations of the wall through which the pipe had passed; apart from these the bath was an isolated survival.

<sup>1</sup>"Notes on the Ruins of Muqeyer," in *J.R.A.S.* 1855, pp. 260 ff., 414 ff.



At 0.90 m. minimum depth below the foundations of these plano-convex brick walls was a second building level. This was best preserved in Squares MN 7-9; in Squares MN 9 was a long room with a doorway in its NE wall and a mud floor; in Squares MN 7 was another long narrow room with a pavement of plano-convex burnt bricks 0.29 m. x 0.18 m. x 0.07-8 m. in which were the openings of two drains (Pls. 10,b and 11,a), set only 1.00 m. apart. In both cases the walls seemed to be constructed of *terre pisée* and no bricks could be distinguished in them; they were covered with a fine plaster of reddish mud and the SW wall of the room in Square MN 9 was battered, implying that it was an outer wall, and so was the outer face of the NE wall, so that the chamber seems to have occupied the east angle of a building which included the room in Squares MN 7. The amulet U.6486 already mentioned was in the filling of the latter room, as was a white calcite vase U.6489. A mud floor extended over Square N 8 bounded on the SE by a mud wall; the floor was slightly higher than that of the chamber in Squares MN 7 judging by the point at which the wall-plaster ceased, (the surface of the floor itself was broken and irregular) but that may have been due to there having been a batter along the wall's foot which was dug away; in any case there is enough to prove that the remains in Squares MN 7-9 are parts of one building complex. Beyond what remains of the NW wall there was (Sq. 0 9) a large store-jar sunk in the floor, its projecting rim mud-plastered; in the same square was a pottery drain with its top formed of a perforated slab of limestone (Pl. 45,l). The drains in the floor of the chamber in Squares MN 7 were simpler, the top section being of beehive shape, un-ribbed, and the lower rings having no collars but slightly wider at the top than at the base so that they fit one into the other (Pl. 10,d). Other drains occurred in Squares N 6 (Pl. 45,k) and N 7, 5.50 m. and 2.80 m. respectively to the NE of the chamber, implying, in the absence of any walls, that the same building complex extended at least as far as this in the NE direction; probably it extended at the same level right up to the heavy wall in Squares M-Q 4 which stands near to the edge of the terrace. The drain in Square N 7 had an inlet of bitumen spread over fragments of burnt bricks; the top section consisted of one of the enormous terra-cotta pipes illustrated on Pl. 11,d; the lower trumpet-mouthed part had been broken in antiquity and mended with bitumen, the upper half had telescoped over the lower (v. sketch, Pl. 45,m); below this was a bee-hive-shaped drain-top and below this again the normal pottery rings.

A trench cut in Squares N 5-6-7 (v. Pl. 70) disclosed a mud wall still standing 1.20 m. high whose foundations were about 3.00 m. below those of the building complex just described. At 2.50 m. below this was another wall also built of *terre pisée* with a mud floor against its NE face; against the wall lay a plano-convex mud brick measuring 0.23 m. x 0.125 m. very markedly convex above; here then, there are three definite building strata all of the plano-convex brick period totalling a vertical interval of 5.50 m. In the case of the lowest building, at 2.00 m. above the mud floor there was a stratum of broken sherds of red pottery regular enough to represent a surface and probably an occupation-level; (fragments of copper were found 1.00 m. below this); at the levels 2.95 m., 3.30 m. and 3.90 m. above the same floor there were bands of black and red ash which also denoted occupation or destruction; in the absence, in the narrow confines of our trench, of any building remains at these intermediate levels the rubbish strata are of value as modifying any conclusions about the quick succession of destruction and rebuilding (and therefore the shortness of the time required for the three building levels) which might otherwise have seemed justifiable.

In Square S 8 there was a small patch of paving, plano-convex burnt bricks 0.30 m. x 0.20 m., enclosed by fragments of two plano-convex mud brick walls; it was difficult to say whether this belonged to the walls already described in Squares ST 9 and PQ 8 or was older than them; deep below this there were found standing in a row three peculiar objects of unbaked mud, cones with oval depressions pinched in one side as if for the rudiments of a human or owl face (Fig. 19,a, U.6155).

In Square T 8 was a wall of plano-convex mud bricks 0.23 m. x 0.135 m. standing 1.30 m. high; the face was covered with a good mud plaster. On the NE face was a buttress 1.50 m. wide, with a projection of 0.23 m. at the base reduced above by a batter; in Square S 8 was a second and wider buttress or else a return wall (the face was rough) and there were traces of a branch wall running NE.

In Square R 9, just above the floor of red clay there were found two silver bracelets and a quantity of silver tubular beads corroded together into a mass, Pl. 30, U.6480, a bronze pin of RC Type 1, and a square stamp seal U.6500; the last was at a lower level and may have been underneath instead of above the clay floor, which here was broken.

Squares R 8-9; a Third Dynasty drain running down through the red clay (First Dynasty) floor is cut into the side of a very massive *terre pisée* wall whose foundations are 2.80 m. below that floor. Against it is a big clay "foundation-pot" of the sort found in Square R 8. The wall, its SE face slightly battered, continued into Square R 9 and there broke off, and in front of the broken end was a mud bin, circular, its bottom flush with the wall foundations.

Square R 8; at 1.20 m. below the clay floor and against the broken angle of the *terre pisée* wall just described there was inverted in the soil a (much broken) large clay bowl with ribbed sides, diam. c. 0.35 m.; it was later in date than the mud wall, which had been cut away to make room for the bowl. Beneath it were remains of a piece of matting woven from reed leaves five millimetres broad in a simple criss-cross weave; this had been spread on the ground and on it placed a number of clay pots, Types RC.4 (four intact), 7 (one intact) and fragments of others of these types and apparently of RC.92; in one

were recognisable the remains of vegetable matter forming a sediment as if from cooked food and in others the teeth of a sheep or goat and the lower jaw of an animal of the size of a dog; there were also carbonised remains which may have been burnt ashes or due to decay. Also below the clay floor, its bottom 1.70 m. beneath it, was a circular pit cut in the red soil and lined with the bright greenish clay seen in the terraces; in it were clay vessels of the following types—RC.4 (two), RC.7 (two), RC.108,b (one), RC.109,c (one, roughly hand-made) and RC.110,c (one, and fragments of a second).

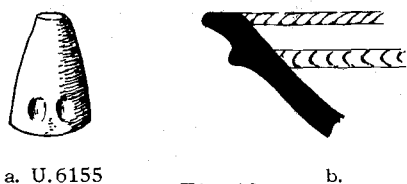

a. U.6155

Fig. 19.

b.

Square P 8; at 0.90 m. below the foundations of the plano-convex brick wall stood inverted in the soil the large bowl Pl. 45,c; at 1.65 m. below the same foundations was a second bowl, Pl. 45,a, in which were twenty-one clay cups of types RC.4 and 7 together with burnt (?) ashes or carbonised remains, a few fish-bones, the shoulder-blade of a sheep or goat, and two or three other animal bones, all broken, lying on reed matting; with these was a knife or wand made from an ox rib, the end rounded, the blade flattened and roughly sharpened, 0.28 m. long and 0.04 m. wide. A fragment

of the rim of a bowl decorated with rope moulding (Fig. 19,b), and a clay tablet with archaic script were found close by.

Square Q 7; at 2.60 m. below the foundations of the plano-convex mud brick wall was another great clay bowl 0.80 m. in diameter, against which was a "mixing-bowl" of Type RC.1, and inside it two saucers of Type RC.4; touching it was a second similar bowl.

Squares G-K 8-10; there was here a long wall buttressed on its outer (SW) face and pierced by a doorway; it was built of plano-convex mud-bricks 0.23 m. x 0.135 m. with some of the courses laid herring-bone fashion; at a later period the doorway was blocked up (with bricks some of which were plano-convex and some flat) and the space behind it was filled in solidly so as to form a raised terrace; the level so formed was exactly that which elsewhere is the First Dynasty level, but the use of flat bricks in the door-filling must be late and would suggest that in this part of the site the First Dynasty level was rather lower than to the NW.

Along almost the whole of the NE face of the sloped mound there were traced what seemed to be terrace walls constructed with large unshaped lumps of stiff yellowish clay, each apparently the contents of one basket, set in a dark clay mortar. The terrace ran through Squares D3 to J4 and then a salient jutted out to the NE with proper walls starting from it and running in the same direction (Squares K 2-4); in Squares M3 and P3 it seemed to re-appear, though the traces were slight, and then, corresponding to the present contours of the ground, there would have been a set-back and the wall is found again, with an initial angle, in Squares S7 and T7, after which a further set-back brings it to Squares U, V, W 8. The outer face of the wall, which appears to have been sharply battered, is weather-worn and very difficult to follow, but its composition differentiates it from the surrounding soil; in level it corresponds well with the *terre pisée* walls of our second archaic stratum (the rooms in Squares MN 7-9), assuming that the foundations of an outer or terrace wall would naturally be deeper than those of buildings on the terrace, or it might be assigned to the raising of the terrace level in the time of the First Dynasty.

In the archaic level was found the bone gaming die U.6551, Fig. 7, a, p. 44.

The interest of this terribly confused and only partially excavated site lies not in its ground-plan—of which indeed very little can be made—but in its relation to Pit F as shown by the section, Pl. 71. The remains of a very heavy terrace or enclosure wall standing only a little above the top of the Flood deposit correspond to the kiln stratum in Pit F; this supports what one would naturally assume, namely that the pottery factory dumps were piled outside the residential area, on the low ground against the wall's foot. The constant disturbance of the soil behind the wall has left only very little evidence of the succession of house levels that we have in Pit F, but there remains just enough to indicate that the process on both sides of the wall was much the same; and when we do get, in the time of the upper terrace wall of *terre pisée*, a floor level with plano-convex bricks that can be traced more or less consistently across the area, it agrees quite well with the *data* in Pit F and confirms the evidence of the pottery from the house ruins in that pit to the effect that the modern surface there has been denuded down to about the level of the Royal Cemetery period.

#### MEREIJIB

During the season 1929-30 an Arab employed on the Iraq railways brought to us some stone bowls which he had found in a grave in a mound called by the local Arabs Mereijib (a generic name for a mound) which lies close to the railway line ten miles south of Ur. The bowls (Catalogue, U.13765A-13769) belonged to the archaic period which we were investigating at the time and there was a chance that the site

might prove of considerable interest; consequently the consent of the Department of Antiquities was asked for its investigation and excavation should that seem desirable (the site lay outside the concession of the Joint Expedition). Permission was given, and Lieutenant Colonel J. R. Tainsh, Director of Railways, accorded facilities which enabled us to undertake the work with the minimum of labour and expense.

The site is a small mound composed of very hard material resembling decomposed gypsum which is overlaid and the pockets in it filled by drift sand. It now rises to a height of about 2.00 m. above the modern plain level (which has risen some 4.00 m. since the drying of the original marshes) and was once higher; it has suffered seriously from denudation. Most of the buildings have been destroyed altogether; of those planned the majority were represented only by a film of coarse whitish grit which was all that remained of cement walling; only one long wall (X on plan) had intact brickwork standing two and three courses high. The graves, at the SW end of the site, had been exposed by denudation, the vessels lying immediately below the surface; others lay open and exposed flush with the surface and the masses of potsherds (not all of one date) which cover the site must result from the exposure and destruction of the majority of the graves.

The cemetery and the house site seem to have been conterminous; certainly the grave plundered by the Arabs before our arrival lay inside the building area; either then the buildings were tomb chapels or they were houses with graves beneath their floors; as each has several rooms and a courtyard the latter alternative is much the more probable.

The buildings were constructed with cement bricks, flat and rectangular, 0.24-5 m. x 0.11-0.125 m. x 0.075-0.12 m.; the variations in size were probably accidental, due to the use of different but contemporary moulds. The walls rested either directly on the hard gypsum formation or, where this was replaced by sand, on a platform of mud bricks 0.21 m. x 0.10 m. x 0.07 m., roughly made but intended to be flat and

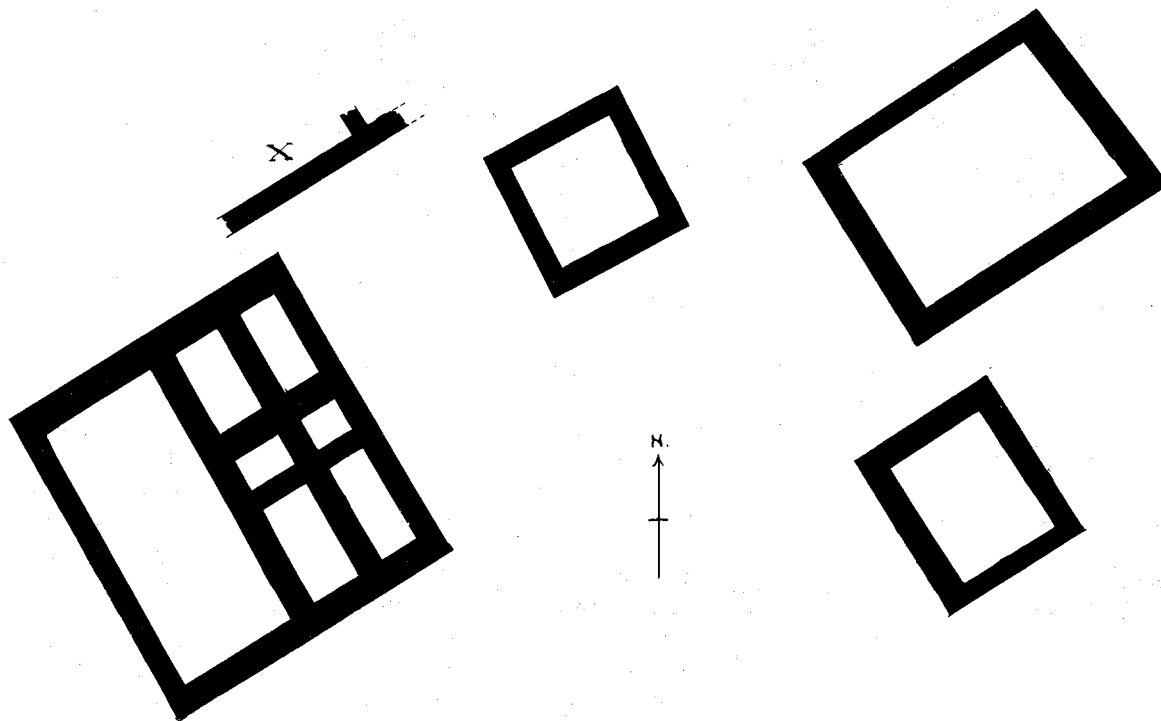

Fig. 20. Sketch Plan of Mereijib. Scale  $\frac{1}{250}$ .

rectangular; outside the main wall there was a pavement of mud bricks of slightly different dimensions, 0.205 m. x 0.09 m. x 0.07 m. these bricks also being so roughly finished that some almost gave the effect of being slightly plano-convex: the pavement was 1.90 m. wide and 0.45 m. thick and rested on sand. Most of the building was rectangular in its lay-out, but there were two apparently curved constructions (not shewn on the plan); not enough of them remained to explain their character but in the centre of one there was a high pile of wood ash resting on a circular hearth of clay sunk below floor level and surrounded with mixed filling; below this was sand which we tested to the depth of 2.00 m. and decided to be virgin soil.

Owing to the denudation most of the pottery was mixed up on the surface and there was no stratification, and only against the long cement wall could pottery be properly associated with the buildings.

Against the inner face of the cement wall were found small roundels of polished black stone with loop piercings behind for copper wire attachments; these belong to mosaic, and prove that the interior of the building had been thus decorated. There was a great deal of al 'Ubad painted pottery (including

Types aU.3, 4, 23, 24, 25, 26) but all was at least as late as al 'Ubaid II; the most characteristic of the al 'Ubaid I motives were conspicuously lacking and the bulk of the wares might well have come from the al 'Ubaid II graves (designs 1 and 9 on Pl. 46 both occurred). Clay sickles and bent clay "nails" were also found here. The other pottery against the cement wall included examples of the "flower-pot" bowl Type JN.2, one of Type JN.149, and a number of cylindrical pots of coarse reddish clay 0.19 m. high and 0.04 m. in diameter (base 0.025 m.) which might have been used for wall inlay (Fig. 21, a): there were fragments of

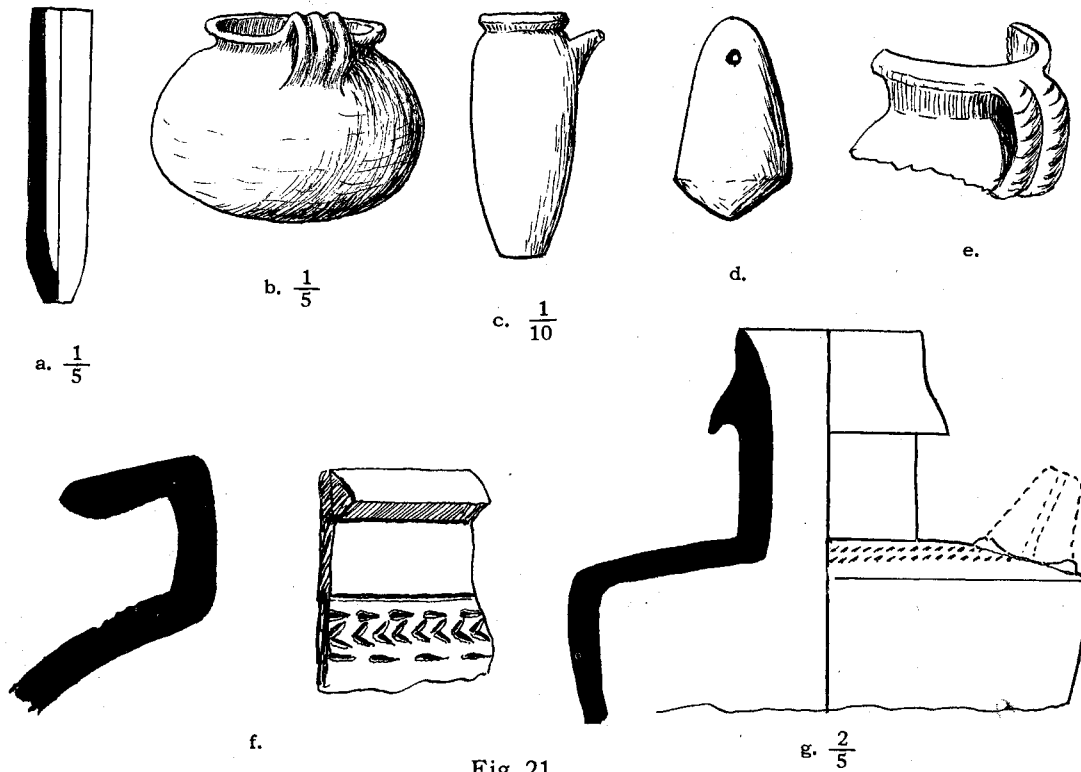
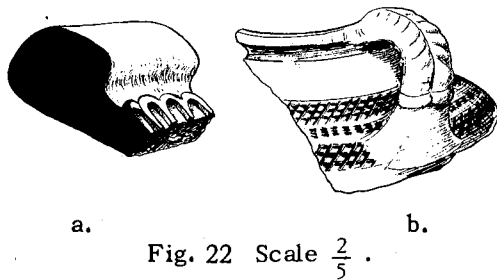

Fig. 21.

vessels with loop handles and a piece from the rim of a very large bowl (hand-made with raised decoration below the rim, Fig. 22, a).

In one of the rooms there lay together a polished celt of dark brown stone, type as Pl. 14, U.17943, an oval rubbing-stone or quern of coarse white limestone, a black pebble pounder, two clay balls, fragments of a handled jug of green clay, hand-made, Fig. 21, b, ht. 0.13 m., and of another hand-made jug of red clay, ht. 0.32 m., Fig. 21, c. Elsewhere in the house ruins there were found quantities of clay roundels pierced each by one hole and in some cases decorated with incised circles, sometimes pierced with two holes, sometimes marked with an incised cross; they lay in piles and had evidently been strung together on a cord, though of that all traces had vanished; the analogy of Tell Asmar shews that they are net-sinkers. With them were other clay objects as Fig. 21, d, which presumably served the same purpose.

Fig. 22 Scale  $\frac{2}{5}$ .

There were a fair number of flints, the ordinary spoon-shaped hoe, and the long oval type (Pl. 12, c) and some of the stone drill-heads for boring the interiors of stone bowls (v. Pl. 13, U.16405 and Fig. 15, b); some lumps of rock crystal and carnelian and fragments of polished white obsidian pierced for inlay witnessed industry of a more ambitious sort. Scrabbled and incised decoration on pottery was fairly common, e.g., on a fragment of an elaborate jug, Fig. 22, b, and another, Fig. 21, f, the latter from a pot with very strong sharp outlines quite characteristic of the site; the fragment of a jug with a double twisted handle, Fig. 21, e, is noteworthy; from one of the plundered graves came the pot, Fig. 21, g, in drab clay, the shoulder ornamented with a double row of small flecks; raised and pinched rope-patterns were also common. Flung out from a grave opened by the modern plunderers we found an example of the slender goblet Type JN.25; and on the site, and especially at its SW end where were the graves, fragments of reserved slip were numerous, and in this area the pottery was almost invariably wheel-made. A fragment of a terra-cotta relief giving the hand and arms of a human figure was found on the surface and was certainly

late; also on the surface was a fragment of an alabaster vase with part of a two-line inscription in archaic characters, a dedication to a god NE . . . (dar?), U.15561.

On the top of the mound there had been some graves made of two large jars set mouth to mouth; here too were found a few loose bricks of Bur-Sin. There had therefore been a late occupation of the site of which the traces left were very scanty. The site had evidently been occupied first in the period al 'Ubaid II and although no Jamdat Nasr painted pottery was found yet from the presence of the plain bowl Type JN.2, which is found in the Jamdat Nasr graves, it is reasonable to suppose that it was inhabited throughout the Uruk period, to which the cement buildings should be due, up to the close of the Jamdat Nasr age when the reserved slip ware is most common and the goblet Type JN.25 comes for a brief space into fashion. Whether the Third Dynasty bricks mean continuous occupation up to that date or a resettlement of the deserted site it is impossible to say.



## APPENDIX II

## DETAILED DESCRIPTION OF THE GRAVES OF THE AL 'UBAID PERIOD

## Pit F

- PFG/A,B,C C7  
 Level 5.80 m. The three bodies, wrapped in matting, lay close together in the stratum of kiln wasters and immediately below a mass of broken mud brick. The bones were in very bad condition and difficult to trace; the skulls were about 1.00 m. apart. With A there were no objects; by the skull of B was a white limestone cup Type aU.13, U.14971, and a small clay cup, broken; by the skull of C was the long pointed base only of a large clay vessel of light red ware.
- PFG/D D6  
 Level 6.10 m.  
 (Plate 4,c) Disturbed; only the pelvis and leg-bones preserved; against them was a line of mud bricks which returned by the feet to make two sides of a rectangular enclosure, and there were a few loose broken mud bricks lying over the body; the grave would therefore seem to have been brick-lined. No objects.
- PFG/E D5  
 Level 6.00 m. The body lay on its left side, the hands in front of the face, the legs very slightly flexed, the head W; by it were remains of mud-brick but not enough to witness to a built tomb. Under the head was the limestone bowl U.14975 of Type RC.28; by the hands a steatite mace-head U.14974 and a clay disk with a hole through it between the centre and edge; at the neck were some small shell beads U.14973, and behind the back a cup Type aU.12, of greenish drab clay, ht. 0.10 m.

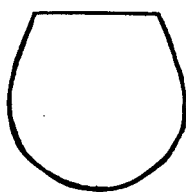

Fig. 23. PFG/E

- PFG/F C4  
 Level 6.30 m. Body wrapped in matting lying straight on its back, hands folded over pelvis, head NW with the face turned to its right; the legs missing. It lay immediately below the foundation of the lowest kiln. By the rt. arm a polished stone axe-head, U.14990, Pl. 14, a copy of a metal original; above the head a cup Type aU.12, of greenish drab clay, ht. 0.095 m. and fragments of another light drab clay cup.

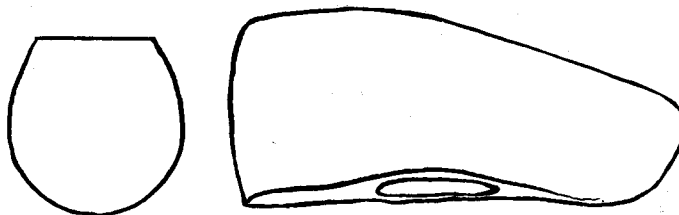

Fig. 24 PFG/F

- PFG/G E7 Body on its left side, legs almost straight, arms bent with hands to face, head missing, bones in bad condition. By the upper part of the body a copper spear-head U.14992, Pl. 30; by the feet remains of a vase of red clay having on the shoulder a thin wash of haematite, not burnished, rim missing, apparently Type aU.33.



Fig. 25. PFG/G

- PFG/J D5 The grave, cut down 0.60 m. into the silt deposit, lay in the side of our pit and could not be properly excavated, only parts of the bones being seen. By the body was a clay bowl Type aU.3a, diam. 0.315, ht. 0.09 m., with plain black border, a bowl of plain red clay Type aU.3b, a pedestal vase Type aU.9b, and fragments of another vase of drab clay.

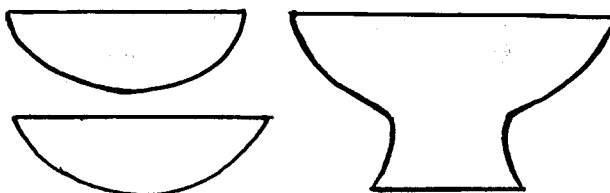

Fig. 26. PFG/J

- PFG/K D6 The bones were too badly decayed for their position to be determined; under them was a group of clay vessels thus - Type aU.3b, plain red ware, diam. 0.16 m.; Type aU.9b, three in plain drab clay and one in plain red, ht. 0.09 m.; Type aU.24, two in plain drab clay, ht. 0.125 m.; Type aU.25, U.15335, ht. 0.10 m., greenish drab clay with bands of black paint, Pl. 18.

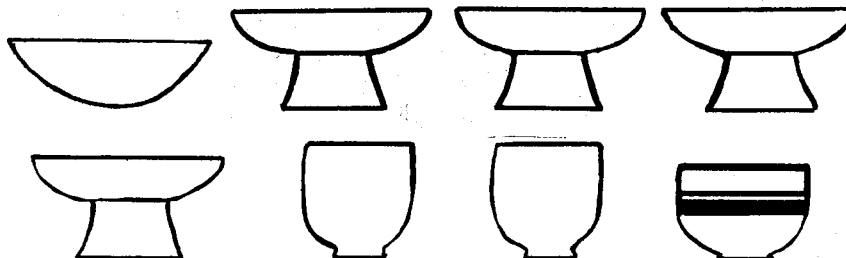

Fig. 27. PFG/K

- PFG/L E6 Eight skulls together with other bones lying in confusion; none of the skeletons intact; they occupied a rectangle about 2.50 m. x 1.50 m. and five skulls were at one end of this and three at the other. On the arm bones of one were many small paste ring beads originally glazed. With the bones were clay vessels thus - Type aU.3a, four examples in drab clay, diam. 0.15 m., two of them inside a pedestal vase Type aU.9a, of light yellowish-drab clay, ht. 0.10 m.; there was a second example of Type aU.9a and one of Type aU.24, plain yellowish drab clay, ht. 0.095 m.

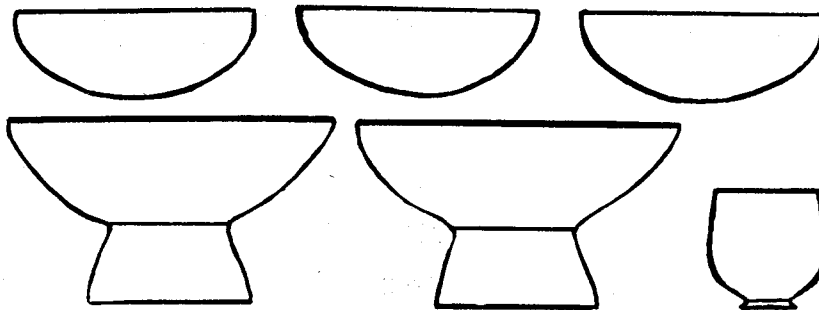

Fig. 28. PFG/L



PFG/M

D5  
Level 5.00 m.  
(Plate 5,a)

Two bodies lying face to face, the hands over the pelvis, the legs slightly flexed, the leg bones of one above those of the other; on the arm of the upper body were minute ring beads of white shell, U.15368; by the legs were clay vessels thus—Type aU.3a, three examples in plain red or pinkish drab clay, one in red, diam. c. 0.15 m.; Type aU.3b, one in drab clay, diam. 0.155 m.; Type aU.25, with bands of black paint on a drab ground, U.15350, Type aU.24, two examples in plain drab ware, ht. 0.10 m. Behind the bodies were remains of the skull of an ox (?) and by the feet but 0.40 m. higher up were animal teeth.

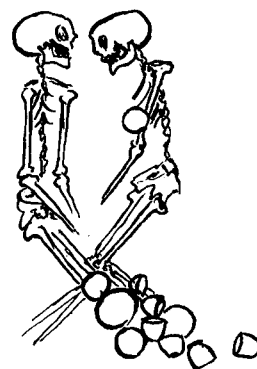

Fig. 29

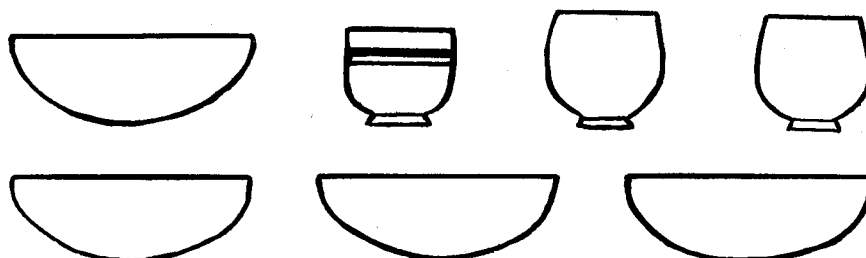

Fig. 30. PFG/M

PFG/N

D5  
Level 4.90 m.

No trace of the bones could be found; the grave consisted of a group of clay vessels lying in confusion. Type aU.3a, 5 examples in drab or light red ware, diam. c. 0.16 m.; fragments of a flat dish, apparently Type aU.4, of green clay with border of black paint, diam. 0.22 m.; Type aU.7, drab ware with black border, diam. 0.20 m.; Type aU.24, U.15366, greenish drab ware, ht. 0.09 m. and fragments of another of light red clay with buff surface; Type aU.25, U.15351, greenish clay with bands of black paint, ht. 0.12 m.; U.15352, similar, and one plain, of drab ware, ht. 0.08 m.; Type aU.34, of greenish clay, plain, fragmentary.



Fig. 31. PFG/N

PFG/O

E7-8  
Level 3.30 m.

The grave, lying under our stairway, could not be properly excavated; only a few bones were found together with the clay vessels. Type aU.1, fragmentary, very thin greenish drab ware, diam. c. 0.15 m.; Type aU.2, frag-

PFG/O  
(cont'd.)

mentary, plain drab ware; Type aU.23, U.15531, of green clay with bands of black paint, ht. 0.09 m., and U.15374, similar, fragmentary; Type aU.33, of light red clay, ht. 0.11 m.; Type aU.39, U.15375, with design in black paint; Type aU.47, of pale cream-coloured ware, fragmentary. Also the body (the head anciently broken off and missing) of a terra-cotta figurine of a nude female, U.15376, Pl. 20.

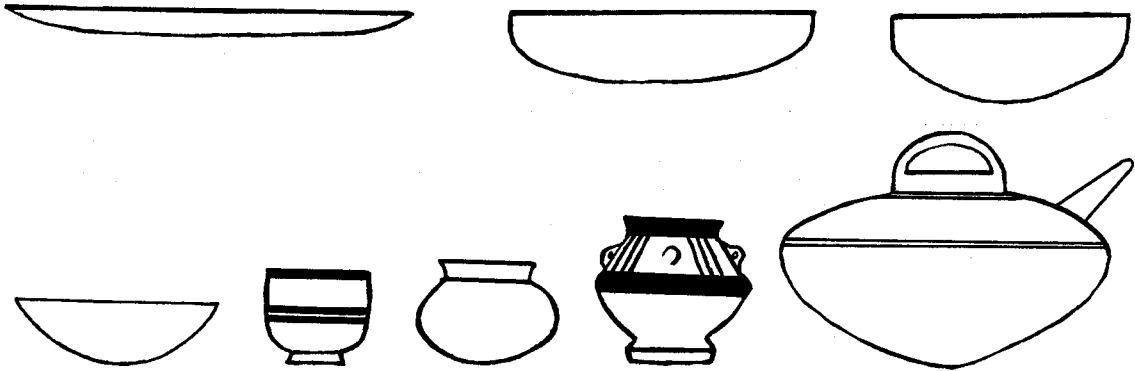

Fig. 32. PFG/O

PFG/P

E7  
Level 3.10 m.  
(Plate 6, a)

Only the skull remained (in bad condition) together with a group of clay vessels. Type aU.21, U.15535, of green clay with bands of black paint, ht. 0.115 m.; Type aU.23, U.15382, Pl. 18, cream-coloured clay with design in black paint, ht. 0.07 m., diam. 0.125 m.; U.15383, Pl. 18, similar; Type aU.25, U.15534, of green clay with design in black paint, ht. 0.06 m.; Type aU.32, of light drab clay, ht. 0.06 m.



Fig. 33. PFG/P

PFG/Q

D5  
Level 3.60 m.  
(Plate 6, b)

Part of the floor of the grave was paved with fragments of pottery, mostly from one big painted pot. The bones had decayed and could not be traced. Against the edge of the pottery mosaic floor was a single bone of a small bird. On or close to the pavement were seven clay vessels – Type aU.4, U.15521, with a border of black paint, diam. 0.42 m.; Type aU.10a, of plain drab clay, ht. 0.12 m.; a second similar, ht. 0.095 m.; Type aU.23, U.15523, of cream-coloured clay with design in black paint; Type aU.32, of rather rough light drab clay, ht. 0.20 m.; Type aU.43, U.15602, of red clay with design in dark reddish purple, Pl. 34; Type aU.55, U.15618 (fragments) of greenish drab clay with border of black paint.

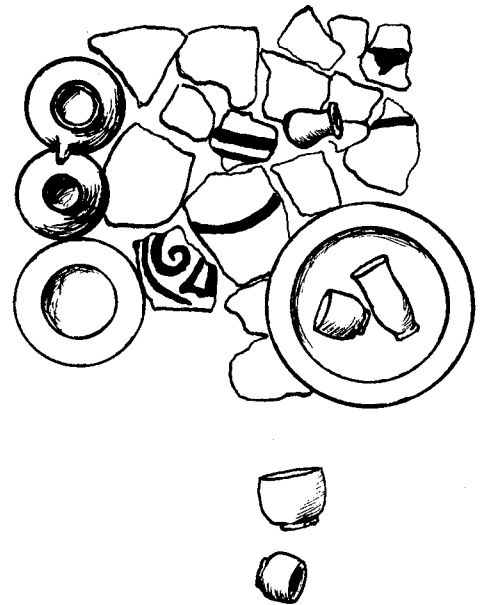

Fig. 34

PFG/Q  
(cont'd.)

Just off the pottery pavement lay, broken in two parts, a terra-cotta figurine of a nude female, U.15380, Pl. 20.

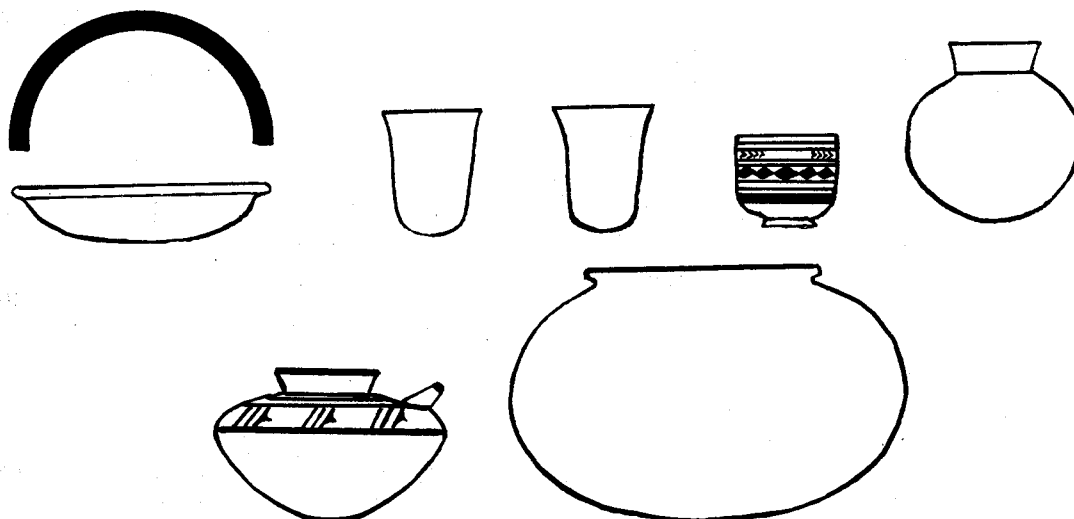

Fig. 35. PFG/Q

PFG/R

D7  
Level 2.60 m.

The grave lay in the side of our pit and had to be cleared by tunnelling; the details of its arrangement therefore could not be accurately recorded; all the clay vessels were crushed and mixed with them there were fragments which seemed not to belong to the grave: of the bones virtually nothing was left. Apart from fragments of unknown shape the vessels were— Type aU.5, U.15619; Type aU.16, U.15501, Pl. 18, of greenish drab ware with design in black paint, ht. 0.10 m.; Type aU.23, U.15561, pinkish cream clay with design in chocolate brown; U.15560, red clay with bands of black paint; Type aU.48, U.15394, Pl. 17, design in black paint on creamy ground, ht. 0.09 m.; and fragments, probably Type aU.55, U.15620, a large vase of greenish drab ware with a design of spirals in black paint. An example of Type aU.9a lay by the grave but seemed not to belong to it.

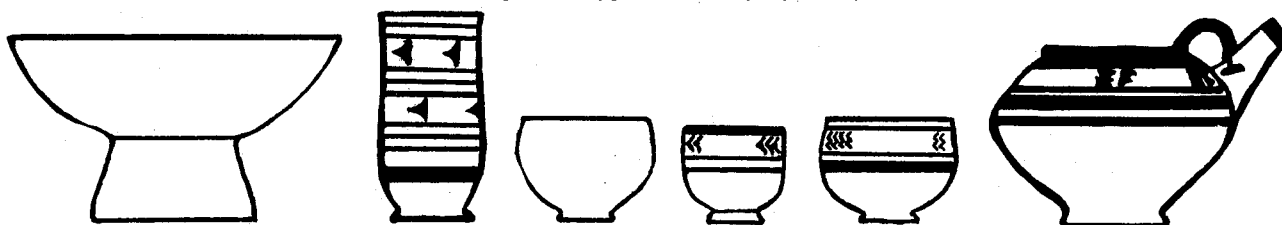

Fig. 36. PFG/R

PFG/S

D5  
Level 3.60 m.

The grave lay close to PFG/Q, on the SE side of it; there remained only a skull on each side of which was a clay cup of Type aU.25; one, U.15567, had a design in chocolate brown paint on a drab clay; the other, U.15568, had a design in black paint on greenish clay, Pl. 33.



Fig. 37. PFG/S

PFG/T

E7  
Level 3.00 m.  
(Plate 5, d)

The grave had been a rectangular trench about 3.00 m. x c. 0.60 m. which for half of its length was paved with a rough mosaic of broken pottery; the body was laid with its head on this pottery floor and most of the trunk and the legs on the bare soil. The bones were so far decayed that the position of them could not be definitely ascertained; but it seemed to be extended on its back with the hands on the pelvis; the general position was SW x NE with the head SW. In the same grave was a second skull 0.20 m. away from

PFG/T  
(cont'd.)

the first, probably an intrusive burial; most of the skeleton had disappeared. Close to the knees of the first body were fragments of a third skull. It was clear that the grave was made for the first body, to which all the offerings belonged, and this burial was undisturbed whereas the other two were but fragmentary. On the right wrist of the body were beads (U.15378) of shell and black steatite, strung in a number of parallel rows; by the hands, resting on the pelvis, was a terra-cotta figurine, U.15379 with remains of red paint on the cheeks and black eyes and hair, Pl. 20. Close to the knees lay a clay bowl, Type aU.8, U.15538, greenish clay with a broad border of black paint, diam. 0.25 m.; against it a cup, Type aU.23, U.15539, Pl. 18, of greenish ware with design in black paint, ht. 0.08 m.; underneath the bowl was a cup, Type aU.25, U.15536, of drab clay with design in black paint, fragmentary, and with it a second terra-cotta figurine of a nude female with bitumen head-dress, U.15385, Pl. 20.



Fig. 38

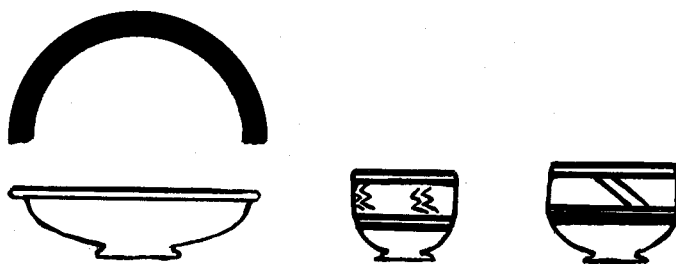

Fig. 39. PFG/T

PFG/U

E7  
Level 3.20 m.

The grave lay close to and just above PFG/T; of the bones only parts of the skull remained, and that was the skull of an infant. On either side of it was a clay cup, one Type aU.25, U.15391, of cream-coloured ware with bands of black paint, ht. 0.10 m., diam. 0.14 m.; one Type aU.26, U.15392, of greenish clay with bands of black paint, ht. 0.08 m., diam. 0.13 m. Under the skull was a bowl, Type aU.2, of plain drab ware, diam. 0.21 m.; below this again but with the remains of another skull (that mentioned as the third in PFG/T) was a cup, Type aU.23, U.15386, of greenish drab clay with design in black paint, ht. 0.10 m., diam. 0.12 m.



Fig. 40. PFG/U

A few centimetres below this were found fragmentary bones of yet another body, and 3 clay vessels. The graves must have been separate, but it was difficult to assign the vessels to one rather than to the other, and they were therefore labelled PFG/U *bis*, in that any or all of them might really belong to PFG/U. They were – Type aU.2, greenish ware, diam. 0.27 m.; Type aU.25, U.15395, Pl. 19, of greenish clay with black paint bands, ht. 0.10 m., diam. 0.14 m.; Type aU.32, of light drab clay, ht. 0.13 m.

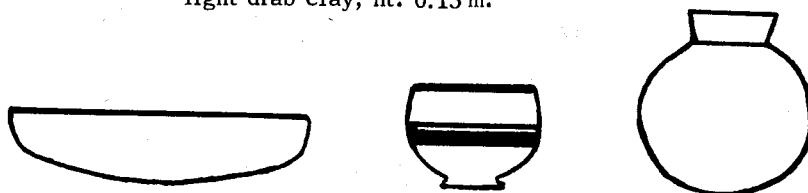

Fig. 41. PFG/U *bis*

- PFG/V D5  
Level 3.20 m. Little of the body remained, but enough to show that the clay vessels had been placed close to the head and against the knees respectively. They were – Type aU.3, U.15533, Pl. 17, with black paint design on drab ground, ht. 0.06 m.; Type aU.3b, plain drab clay, diam. 0.21 m.; Type aU.23, U.15569, Pl. 18, of light drab clay with design in brownish black; Type aU.25, U.15605, Pl. 18, of pinkish drab clay with design in black paint; Type aU.26, U.15532, Pl. 18, creamy drab clay with design in black paint, ht. 0.09 m.; Type aU.43, U.15626, light drab clay with design in black paint.



Fig. 42. PFG/V

- PFG/W D4  
Level 3.80 m. There remained of the grave only part of a paving made of broken pottery and by it three clay vessels – Type aU.10a, plain light red clay, ht. 0.10 m. Type aU.25, U.15550, green clay with bands of black paint, ht. 0.10 m., and U.15551, warm buff clay with design in black paint, ht. 0.10 m.



Fig. 43. PFG/W

- PFG/X D4  
Level 3.80 m. Of the grave there remained only fragments of the skull and of a few other bones, and a single clay cup, Type aU.25, U.15537, Pl. 18, of drab clay with bands of black paint. Below this and possibly but not certainly belonging to the same grave was a cup Type aU.23, U.15390, of drab clay with bands of black paint, ht. 0.10 m., diam. 0.10 m.



Fig. 44. PFG/X

- PFG/Y E7  
Level 3.50 m. The grave was in the side of the pit and could be only partially excavated by tunnelling. The skull rested on two clay vessels, a bowl, Type aU.2 (?) in fragments, and a cup Type aU.25, U.15393, of greenish ware with design in dark brown paint, ht. 0.08 m., diam. 0.14 m.



Fig. 45. PFG/Y

- PFG/Z D5  
Level 3.15 m.  
(Plate 5, c) The grave was alongside PFG/Q but at a lower level. The body was relatively well preserved (it was waxed and removed intact) and lay extended on its back, the hands on the pelvis, the head a little E of N. All the pottery was grouped together by the feet. Type aU.3a, U.15400, of flaky black clay; Type aU.4, U.15397, greenish clay with design in black paint, ht. 0.05 m., diam. 0.25 m.; Type aU.10a, plain greenish drab

## DESCRIPTION OF GRAVES

PFG/Z  
(cont'd.)

clay, ht. 0.11 m.; Type aU.25, U.15384, Pl. 18, buff clay with design in black paint, ht. 0.09 m., diam. 0.10 m.; U.15389, cream-coloured clay with design in black paint, ht. 0.10 m., diam. 0.10 m.; U.15541, drab ware with design in black paint, ht. 0.08 m.; Type aU.26, U.15387, Pl. 19, greenish clay with bands of black paint, ht. 0.09 m., diam. 0.11 m.; U.15540, similar, ht. 0.09 m.; Type aU.29, plain light drab clay, ht. 0.105 m.; Type aU.47, U.15556, plain cream-coloured ware, diam. 0.25 m.; Type aU.49, plain light red ware, ht. 0.105 m., and fragments of a large pot of thin fabric, greenish clay, too broken to type.

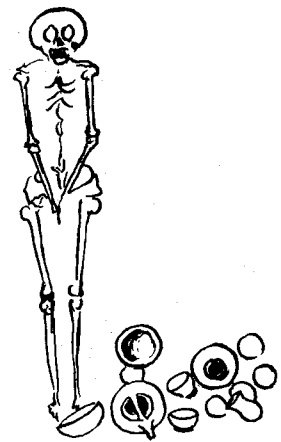

Fig. 46

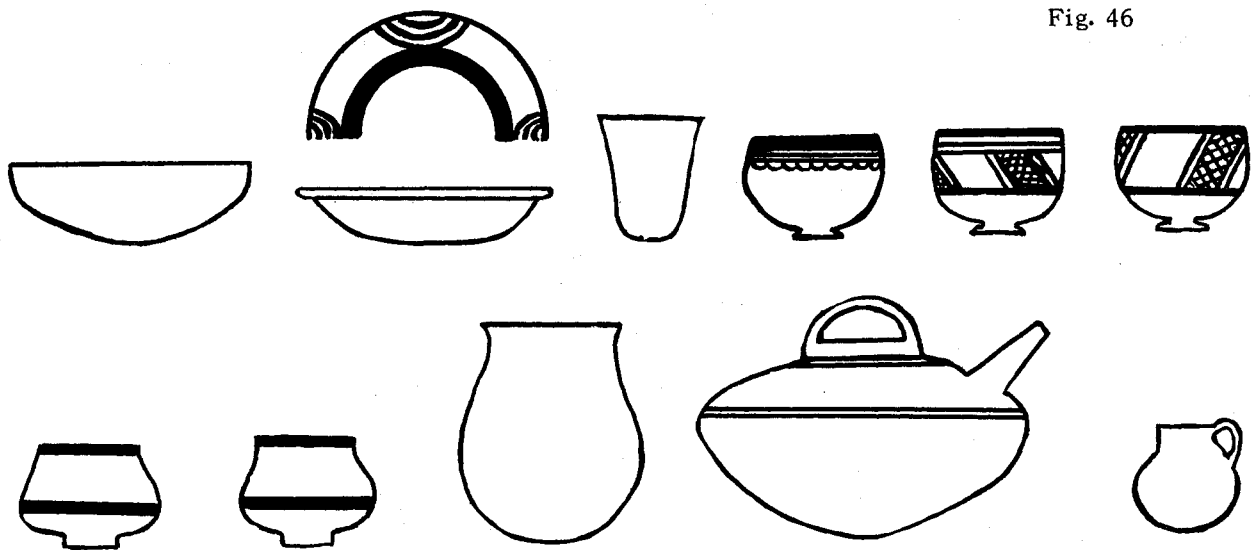

Fig. 47. PFG/Z

PFG/AA

E7  
Level 2.90 m.  
(Plate 6, c)

The body lay extended on its back (apparently; but little was left of the bones) with the head SW; the pottery offerings were by the feet and against the right side of the body; with them were parts of a second skull and of a leg bone, and a little way off were some human teeth. Type aU.2, two examples in plain drab ware, diam. 0.24 m. and 0.26 m.; Type aU.3a, plain drab clay, diam. 0.20 m. Type aU.4, U.15623, with border of black paint on drab ground; Type aU.8, U.15558, Pl. 17, of green clay with border of black paint; Type aU.25, U.15505, Pl. 17, of pinkish drab clay with design in black paint, ht. 0.12 m., and another in green clay with design in black, one of drab clay with black bands and one plain, of pinkish cream ware; Type aU.30, of greenish drab clay, plain, ht. 0.16 m.; Type aU.47, U.15622, with design in black paint on buff clay; and fragments of two vessels, types uncertain, one painted, the other in plain ware, spouted.

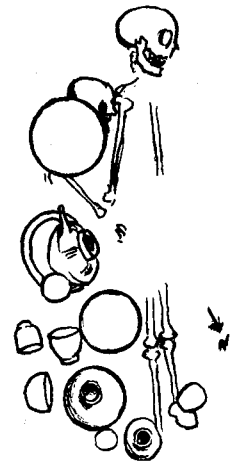

Fig. 48

PFG/AA  
(cont'd.)

Fig. 49. PFG/AA

PFG/AA *bis* E7  
Level 2.90m.

Close to the south end of PFG/AA but probably not really connected with it was a skull (almost touching some of the clay vessels in that grave) with which lay a small roughly-made bowl, Type aU.17, red clay, diam. 0.06m., and a terra-cotta figurine of a woman holding an infant, U.15506, Pl. 20.

Fig. 50. PFG/AA *bis*PFG/BB  
C4  
Level 3.00m.

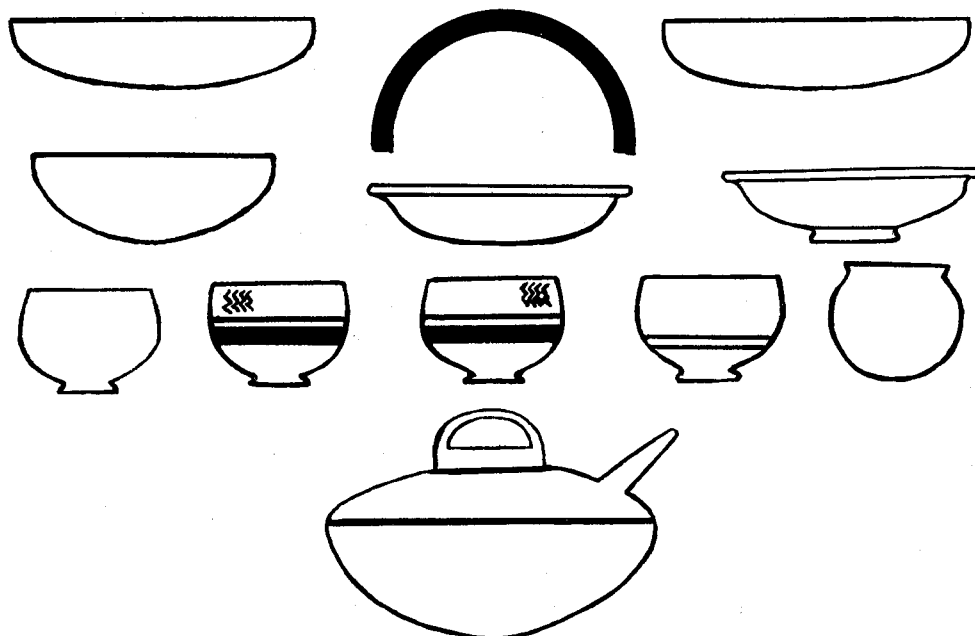
A scattered collection of clay pots with a few traces of bone by them. Type aU.4, plain; Type aU.19, thin ware, drab, with bands of brown paint, U.15608; Type aU.47, of plain cream-coloured clay, diam. 0.19m.

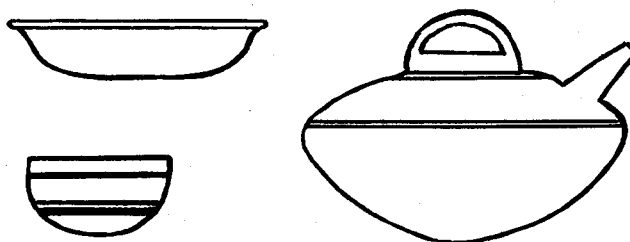

Fig. 51. PFG/BB

PFG/CC  
E6  
Level 2.80m.

The bottom of the grave-shaft was paved with pieces of broken pottery on which the body was laid extended on its back, the hands over the pelvis, the head a little S of W. The clay vessels were - Type aU.2, plain of drab clay, much broken, not necessarily belonging to the grave; Type aU.7, U.15548, green clay with border of black paint, ht. 0.09m. diam. 0.21m.; Type aU.8, U.15553, with border of black paint; Type aU.23, U.15510, green clay with bands of black paint, ht. 0.089m.; U.15574, greenish drab clay with design in black paint; Type aU.30, very rough drab clay, ht. 0.10m.; Type aU.32, plain light drab clay, ht. 0.21m.; Type aU.34 (?) completely crushed, a small example in red clay, but the precise type doubtful; Type 52, light drab clay, plain, ht. 0.075m.

## DESCRIPTION OF GRAVES

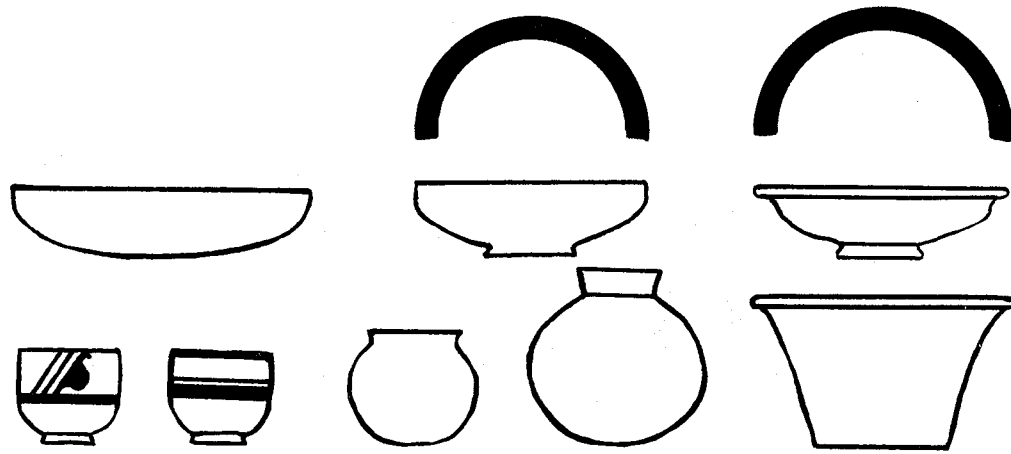

Fig. 52. PFG/CC

PFG/DD

C4  
Level 3.20m.

Remains of a pavement of red potsherds; the body had completely disappeared; on the pavement lay a clay pot Type aU.47, ht. c. 0.16m., of light drab clay, U.15631.

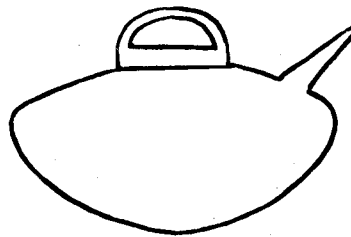

Fig. 53. PFG/DD

PFG/EE

C4  
Level 2.80m.

No signs of bones; lying close together and evidently belonging to one another and to a grave were two clay pots, Type aU.10a, of light greenish drab ware, very thin, ht. 0.13 m.; Type aU.28, of coarse reddish clay, ht. 0.38 m.; also two terra-cotta disks pierced each by two holes, cf. Fig. 5, p. 14.

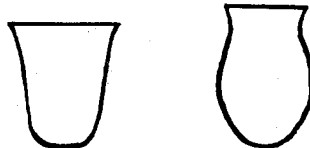

Fig. 54. PFG/EE

PFG/FF

C4  
Level 3.60m.

Of the grave there remained only a pavement of bits of broken pottery; the bones had completely disappeared; on the pavement were 3 clay vessels – Type aU.3a, U.15601, of drab clay with border of black paint, Pl. 17; Type aU.20, roughly made of plain light greenish drab clay, diam. 0.09m.; Type aU.34, U.15562, of red clay, the neck painted black and red-brown circles painted on the shoulder; much crushed.

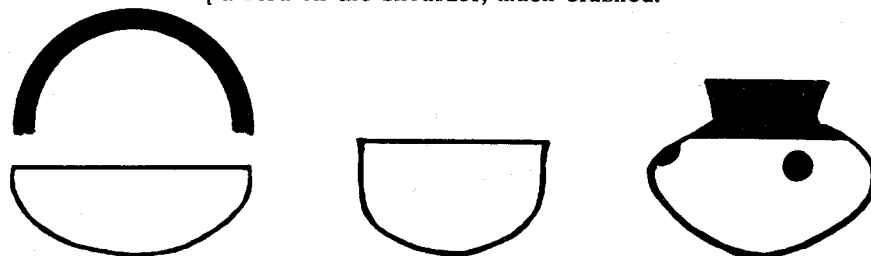

Fig. 55. PFG/FF

PFG/GG

E6  
Level 4.00m.

The body lay almost due E x W, the head W; it was on its back, fully extended, with the hands over the pelvis. Close to the head were various



PFG/GG  
(cont'd.)

clay vessels – Type aU.3a, four examples, two of light drab clay, one of red clay and one of red body clay with drab slip; Type aU.10a, plain, of greenish drab ware, fragmentary; Type aU.25, U.15559, plain, rather coarse creamy drab ware; Type aU.31, plain, of light drab ware, ht. c. 0.14 m.; Type aU.38, U.15503, drab ware with design in black paint, ht. 0.10 m.; Type aU.44, U.15502, Pl. 17, of greenish drab ware with design in black paint, ht. 0.065 m.

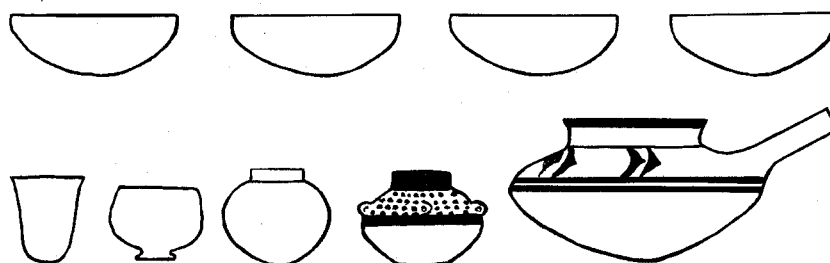

Fig. 56. PFG/GG

PFH/HH

E7  
Level 1.90 m.

The only object was a clay cup, Type aU.23, U.15526, Pl. 19, of light drab clay with design in dark brown paint, ht. 0.11 m.



Fig. 57. PFG/HH

PFH/JJ

E7  
Level 2.20 m.  
(Plate 5, e)

There were two bodies in the grave. The first, better preserved, lay fully extended on its back with the hands over the pelvis, the head SW. On the body, just above the hands but perhaps originally grasped by them, was a terra-cotta figurine of a nude female, U.15507, Pl. 20. Close to the right ear of the body was a lump of bright red haematite. The second body lay side by side with the first; it was in poor condition. The bones were covered with a powdery red pigment (haematite?) as if they had been painted (cf. PFG/KK). The clay vessels were – Type aU.3a, U.15576, of greenish clay with border of black paint; Type aU.7, U.15549, Pl. 19, of greenish clay with border of black paint, diam. 0.285 m.; Type aU.25, U.15543, greenish clay with design in black paint, ht. 0.085 m.; U.15545, Pl. 18, creamy drab clay with bands of black paint, ht. 0.10 m. U.15581, creamy clay with design in black paint; Type aU.31, U.15544, light red clay with band of brown paint round the rim, ht. 0.065 m.; Type aU.38, of light red clay, plain, diam. 0.10 m., fragmentary; Type aU.43, U.15615, light drab clay with design in black paint; Type aU.47, of whitish drab clay, diam. 0.30 m.

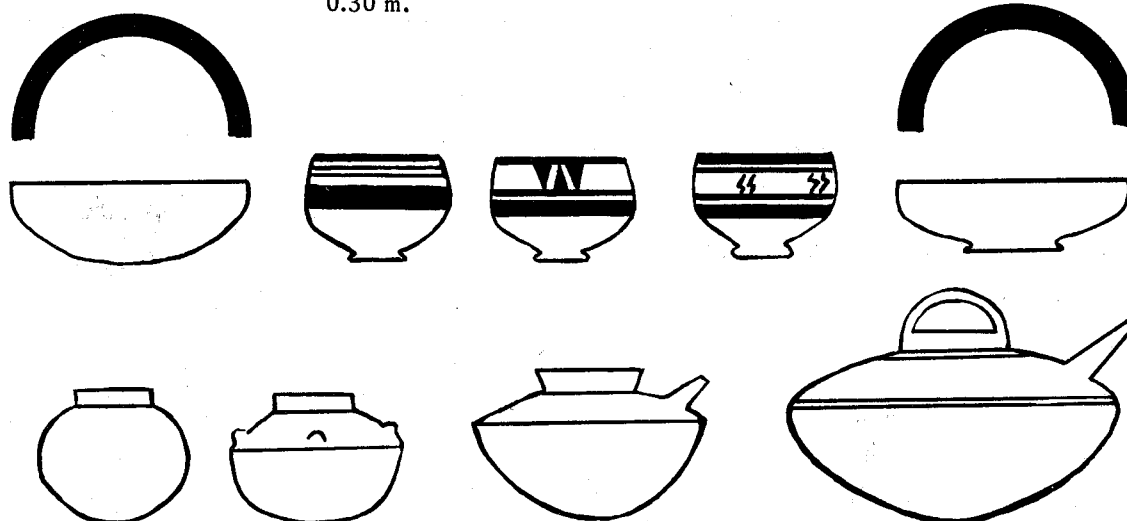

Fig. 58. PFG/JJ

PFG/KK E7  
Level 2.20 m.  
(Plate 5, f)

The body fully extended, on its back, the head SW, the hands folded over the pelvis; on the arms and on the bones of the upper part of the body there was red haematitic powder. By the feet was a group of clay vessels – Type aU.3a, U.15396, Pl. 17, of greenish drab clay with design in black paint, ht. 0.08 m., diam. 0.24 m.; Type aU.31, U.15513, of cream-coloured clay with design in black paint, diam. 0.08 m.; Type aU.42, of drab clay, diam. 0.18 m.

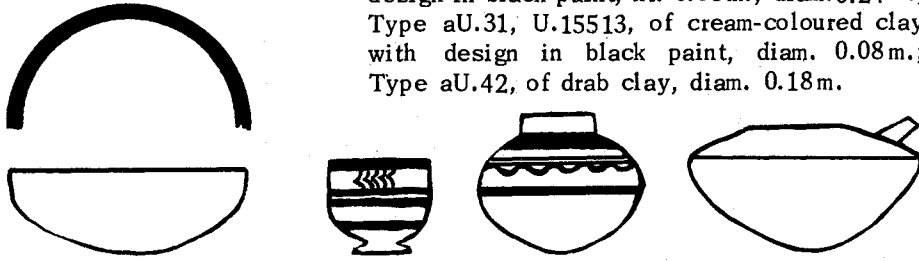

Fig. 60. PFG/KK

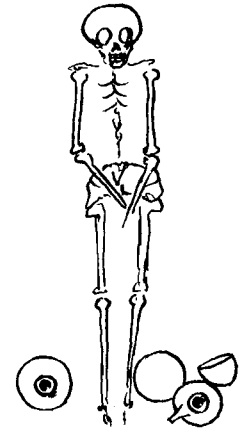

Fig. 59

PFG/LL E7  
Level 1.90 m.

Scanty remains only; a skull in bad condition and by it two clay vessels, Type aU.6, U.15546, Pl. 17, of drab clay with black paint border; Type aU.27, of red clay, ht. 0.14 m., the surface finished by vertical knife-trimming.

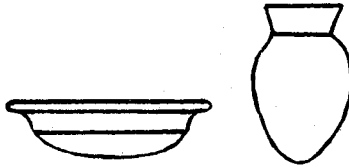

Fig. 61. PFG/LL

PFG/MM E7  
Level 1.50 m.

The grave was dug down through the silt deposit into the underlying stratum of house refuse. The body (the bones very badly decayed) lay fully extended on its back, head SE, the hands over the pelvis. Against its left side were – Type aU.4, U.15517, of light drab clay with border design in black paint, diam. 0.26 m.; Type aU.10a, of light red clay with cream-coloured slip, very thin ware, ht. c. 0.10 m., completely crushed; Type aU.21, U.15573, of cream-coloured clay with bands of black paint; Type aU.23, U.15508, Pl. 19, of greenish clay with design in black paint, ht. 0.11 m.; Type aU.32, of light drab clay, ht. 0.17 m., and another of light red clay, ht. c. 0.10 m., both fragmentary. Against the side of the grave (but perhaps not belonging to it, for there were other bones close by) were also Type aU.4, U.15591, of drab clay with black paint border; Type aU.10a, of red clay, much broken; Type aU.23, U.15570, of cream-coloured clay with design in black paint; Type aU.34, of drab clay with cream-coloured slip and the neck painted black.

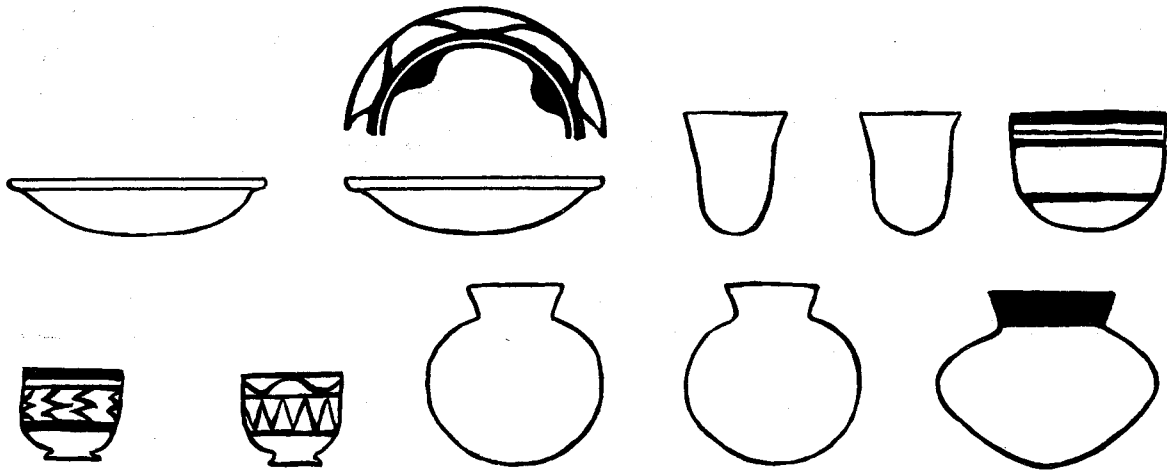

Fig. 62. PFG/MM

- PFG/NN E7  
Level 1.50 m. A badly ruined grave; remains of bones and a broken plate Type aU.4, U.15518, Pl. 19, of greenish clay with design in black paint, diam. 0.16 m.; and a plain clay cone, U.15519, ht. 0.19 m., base diam. 0.105 m.

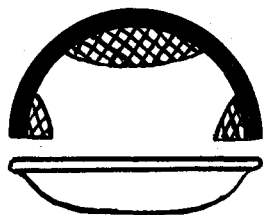

Fig. 63. PFG/NN

- PFG/OO E7  
Level 1.30 m. The grave lay in the side of the pit behind and just below PFG/MM and could be only partly excavated; it contained the skull of what was, judging by the teeth, a young child, and a group of clay vessels – Type aU.4, U.15552, Pl. 19, of greenish drab clay with design in black paint, diam. 0.28 m.; Type aU.30, a roughly-made miniature pot of drab clay, ht. 0.06 m.; Type aU.31, of red clay fired to a bright deep tint, ht. 0.13 m.; Type aU.47, of creamy drab ware, very thin, ht. 0.14 m.

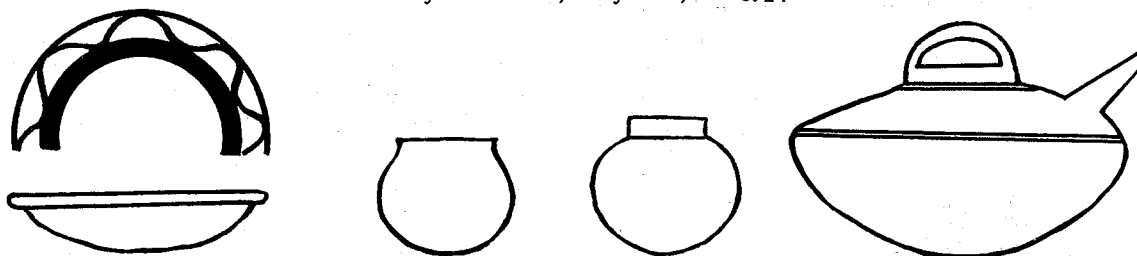

Fig. 64. PFG/OO

- PFG/PP E7  
Level 1.00 m. The grave lay 0.30 m. below the last. It contained a fragmentary bowl, Type aU.3a, U.15554, of light red clay with border of chocolate brown paint; Type aU.33, U.15555, of drab ware with design in black paint, and a polished bone pin, U.15520, Pl. 15.

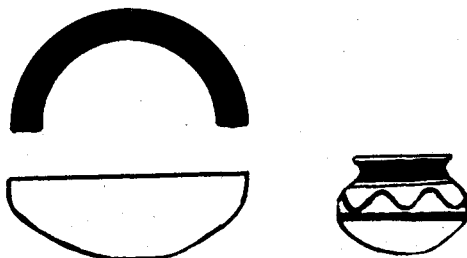

Fig. 65. PFG/PP

- PFG/QQ E6  
Level 1.60 m. The bones were very badly decayed. With them were – Type aU.3a, U.15557, of pink clay with design in chocolate brown paint; Type aU.4, of drab ware with border of black paint; Type aU.50, U.15529, of light drab clay with design in black paint, ht. 0.15 m.; with these were fragments of a terra-cotta figurine of a nude female, U.15516, Pl. 22.

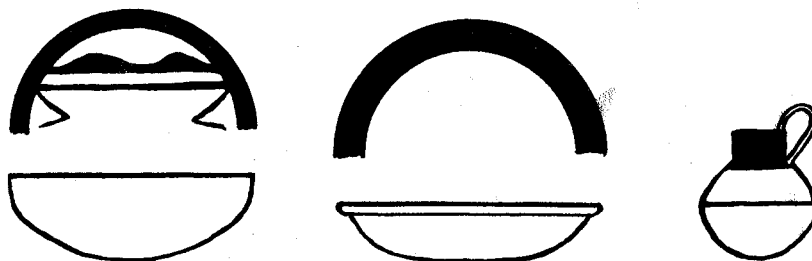

Fig. 66. PFG/QQ

PFG/RR

E7  
Level 1.10 m.

The grave lay close to PFG/OO though at a slightly higher level; it seemed to have been disturbed by the other burials which in this part lay deeper than elsewhere and were very close together. The remains of bones were scanty and in bad condition. Type aU.3a, plain, of light drab clay, diam. 0.25 m.; Type aU.4, U.15580, of green clay with border of black paint; Type aU.23, U.15579, of buff clay with design in red paint; Type aU.31, of light drab clay, the body coarse, the surface water-smoothed, diam. 0.18 m.



Fig. 67. PFG/RR

PFG/SS

E7  
Level 1.10 m.

The grave lay immediately below PFG/OO and consisted of a group of clay vessels only; the bones had decayed away or else lay further into the side of our pit and were not exposed by us. The pots were – Type aU.3a, U.15593, of light drab clay with design in black paint, Pl. 19; Type aU.22, U.15528, of pinkish clay with design in red paint, ht. 0.075 m.; Type aU.23, U.15592, of greenish clay with design in black paint, Pl. 17; Type aU.43, of drab clay, fragmentary.

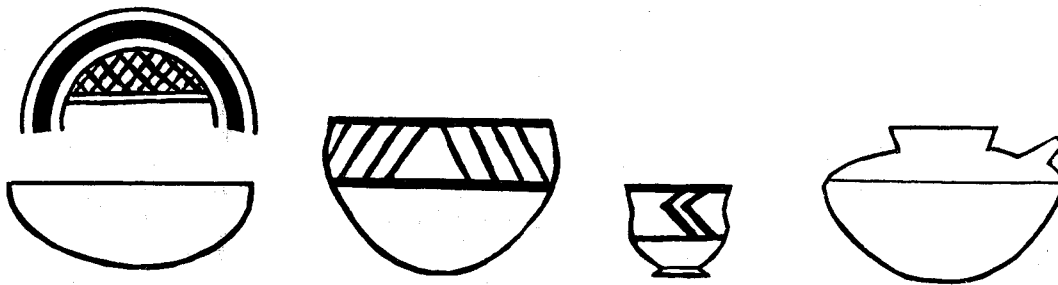

Fig. 68. PFG/SS

PFG/TT

E6  
Level 2.50 m.

The body lay on its back, fully extended, the head a little S of W, the hands folded over the pelvis. By the feet, on the right side, were clay vessels – Type aU.8, U.15589, of green clay with wide border of black paint; Type aU.23, U.15588, of creamy clay flared to pink with design in reddish brown paint, Pl. 18; Type aU.41, U.15614, of rather coarse light red ware, ht. c. 0.10 m., broken, and another similar, of reddish drab ware with finely polished drab surface, much broken, diam. c. 0.15 m.; Type aU.47, U.15625, of red clay with cream-coloured slip and design in chocolate brown paint.

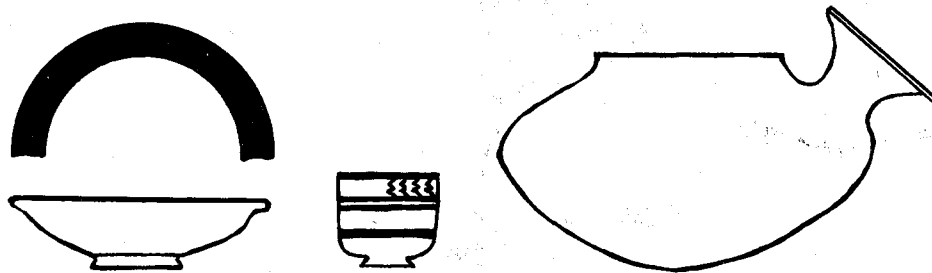

Fig. 69. PFG/TT

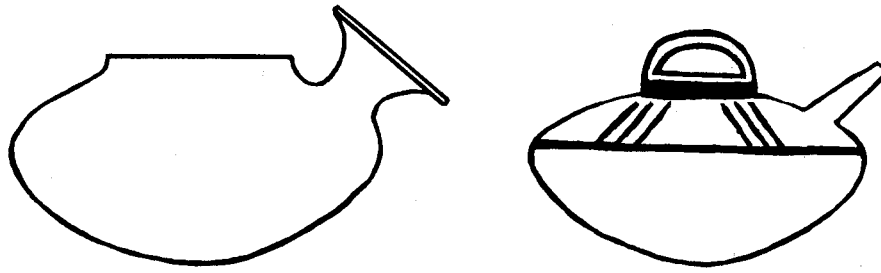

Fig. 69. PFG/TT (cont'd.)

- PFG/UU E6  
Level 1.10m. Of the body there remained only the skull; by it were clay vessels, Type aU.3a, U.15565, of greenish drab clay with design in black paint, Pl. 30; Type aU.10b, of drab clay, thin ware, lying underneath the last, and a second similar cup which was inverted over the mouth of the spouted pot; Type aU.30, U.15525, of greenish clay with design in black paint, ht. 0.055 m.; Type aU.45, U.15624, of pale buff clay with design in purplish paint.

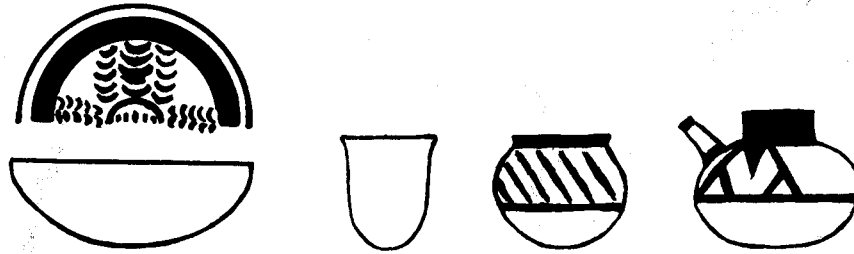

Fig. 70. PFG/UU

- PFG/VV E6 The grave lay in the side of our pit and was only partly excavated. Of the body there remained only the skull against which were heaped the clay vessels. Type aU.4, U.15575, of greenish clay with border of black paint; Type aU.27, two examples in light red clay, ht. 0.13 m. and 0.15 m.; Type aU.29, rather roughly made of red clay, ht. 0.18 m. Close to these but not forming part of the same grave group were fragments of a plate of Type aU.4, greenish clay with design in black paint, and Type aU.30, U.15596, with painted design.

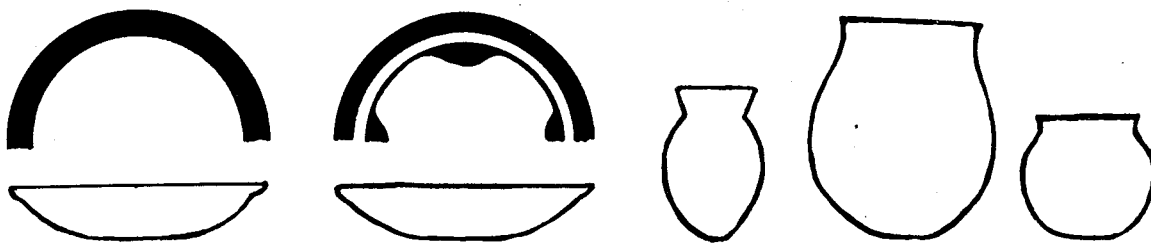

Fig. 71. PFG/VV

## Pit X

- PFG/WW No remains of body. In a group together were the following clay pots – Type aU.21, U.19983, of light drab clay with design in black paint; fragments of a second similar with design in black paint; Type aU.31, U.19982, greenish drab clay with design in black paint; Type aU.38, plain red clay with creamy drab surface.

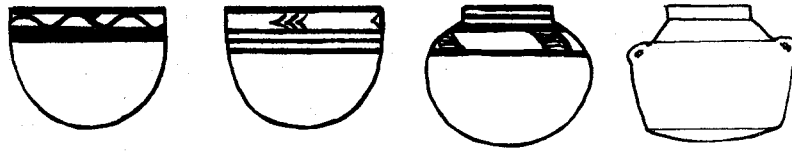

Fig. 72. PFG/WW

## Pit Z

## PFG/XX

Isolated grave at 1.50m. above sea level. The body apparently extended with head SE, but very little of it remaining. With it a painted clay pot, Type aU.47, U.14988, Pl. 19, and fragments of a plain vessel in whitish drab clay, U.14991, resembling Type aU.41, but with a loop handle; also Type aU.2, U.14986, of plain greenish drab clay, diam. 0.31 m. (broken); Type aU.26, U.14987, painted, fragmentary.

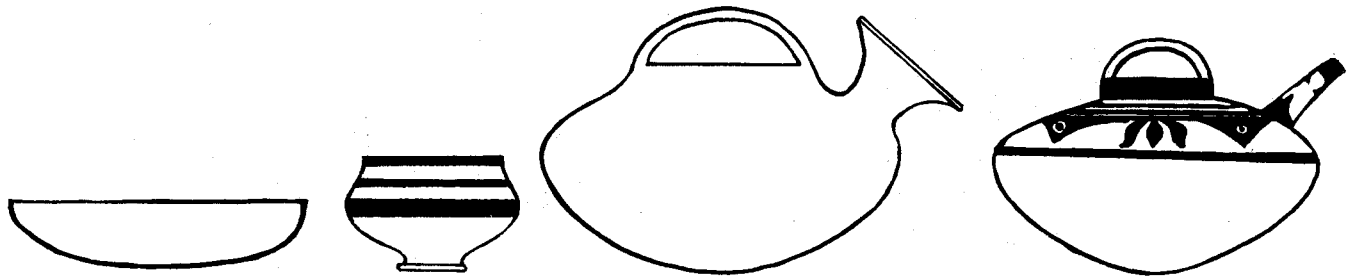

Fig. 73. PFG/XX

### APPENDIX III

#### TABULAR ANALYSIS OF GRAVES OF THE JAMDAT NASR PERIOD

There are tabulated here all Jamdat Nasr graves containing any object of importance in itself or objects numerous enough to constitute evidence for dating.

The graves are classified as

- (A) Early
- (B) Intermediate
- (C) Late

partly on the basis of their position and depth, partly by the nature of their contents, *i.e.* of the stone and pottery vessels found in them; where these include types proved to be specifically early the grave is marked (A); where the types are those common to the whole Jamdat Nasr period the grave is marked (B); where there are specifically late types the grave is marked (C).

Numbers preceded by U are the catalogue numbers of the objects.

Other numbers refer to the type series; in the case of metal vessels the number is preceded by JN; in the case of stone and clay vessels no prefix is given, the reference being to Plates 65-67 (for stone vessels) and to Plates 56-64 (for clay vessels), so that the simplification involves no risk of error – in the catalogue and elsewhere in the text the same type numbers are quoted with the JN. prefix. The pottery type RC.1 occurring in some of the (C) graves is figured in Vol. II, Pl. 251.

In the case of pottery the specification of the type is generally all that is required; where this is not so the type number is supplemented by notes on fabric, etc. Other objects are described in the catalogue.

The graves were found in:

- Pit W (JNG/1-137)
- Pit X (JNG/141-347)
- Pit Y (JNG/348-367)
- Pit Z (JNG/368-370)

## TABULAR ANALYSIS OF GRAVES

## APPENDIX III

Grave No.	Period	Head direction	Attitude	Metal	Beads	Stone Vessels	Pottery Types	Notes
IN PIT W								
1	C	?	only traces of bone	lead tumbler JN.1	-	25: U.18536	1 (three), 4, 20, 54, 111 and fragments	mat burial; the stone bowl U.18533 probably did not belong
2	C	N	on left side	-	-	24: 25: U.18533; 55: U.18437	1, 17, 67 and fragments	
3	B	?	skull only	-	-	11: U.18534	73	
4	B	?	skull only	-	U.18557	-	73 (? two with tops missing)	
5	C	?	no bones left	-	-	17: U.18469, U.18470; 50: U.18436	1, 4 (two), 73	
7	C	?	skull only	-	-	18: U.18664	4 (five), 122	
8	C	?	traces of bone	-	-	-	1, 72, 82, 90 and fragments of a spouted jar and of a large bowl	
9	C	?	traces of bone	-	-	-	4 (three), 141 and five too fragmentary to type	
10	C	?		-	-	4: U.18715 and fragments of limestone bowl	4 (two), 122, 123 and fragments	
10a	C	NW		-	U.18554	-	122 (two)	
11	C	NE	on right side, legs missing	-	-	-	1, 4, 122, 152	mat burial; a clay rattle, cf. Fig. 16, p. 77
14	C	NE		-	-	22: U.18685; 33: (? fragments)	20 (two), 61, 77, 122 (three), 152	
15	C	?	skull only	-	U.18690	-	16, 20 (two), 39, 45, 122 (two)	mat burial
16	C	NE	position doubtful, much contracted	-	-	12: U.18435	20 (two), 39, 77, 122, 152	



17	C	-	-	-	U.18555	fragments of alabaster bowl	25, 90, 141	inverted bowls (type 4) lay above the grave U.18652 probably does not belong
18	C	SW	on left side, spine straight, legs at rt. angles to trunk, knees tightly flexed	-	two steatite rhomboids	21: U.18652; 24: U.18508, Pl. 34	1, 48 (with wash of plum-red paint)	
19	C	NW	only skull left; on right side	-	-	-	65	
20	C	?		-	-	8: U.18684 and fragments of limestone bowl	4 (two), 61, 122	
21	C	SE	not recognisable skull only	-	shell ring	-	1, 20, 61, 152	flint core
22	C	?		-	-	12: U.18689; 27: U.18487; 28: U.18683	20 (two), 39, 152 (three)	base of large jar inverted over grave
24	B	NE	on right side, legs at obtuse angle to trunk, knees tightly flexed	-	-	12: U.18505		
25	B	?	on right side	-	U.18427	16: U.18429	77	
27	C	SE	not recognisable	-	-	26: U.18637 and fragments of bowl		
30	C	SE	on left side	-	-	-	24 (two), 77, 158	
31	C	?		-	-	-	4, 122, 152	
33	C	SW	on right side, body fairly extended	-	U.18433	-	141	mat burial
34	C	?		-	-	13: U.18547; 18: U.18665; 25: U.18655, U.18579	25, 111, 122, 152, 158, and fragments	
35a	C	SE	on right side, fairly extended	-	-	14: U.18661	61	
35b	B	?		-	U.18432	-	111, and a spouted jar (fragments)	
36	C	?	not recognisable	-	-	20: U.18532	59, 65, 122, 133	
37	C	S	on right side	-	-	limestone saucer, crushed	122, and fragments	mat burial; two flint flakes
38	C	?	on left side, tightly contracted	-	U.18430	5, and fragments of	4 (two), 20 (two), 45, 103, 122, 146	the stone bowl 5 had been mended in antiquity with bitumen; two cockle shells; flint knife and core
40	C	?	skull only	Lead tumbler U.18556 JN.1, copper pin U.18426	U.18425	-	20, 158	

## TABULAR ANALYSIS OF GRAVES

Grave No.	Period	Head direction	Attitude	Metal	Beads	Stone Vessels	Pottery Types	Notes
41	C	S(?)	skull and traces of bone	-	-	-	14b (with streaks of red paint on sides), 20, 25, 45, 54 (two), 72, 146	
42	C	S	v. Plate 54.	lead tumbler JN.1, copper chisel (?) copper bowl, JN.2	U.18501 U.18438	4: U.18486, 6: U.18656; 18: U.18515; 27: U.18545, U.18680; 28: U.18597; 30: U.18546; 55: U.18489; 56: U.18506; 57: U.18571; and a bowl, not typed	20, 121, 133 and fragments	conch shell cut as lamp, and shell; button seal U.18442; bowl cut from a shell U.18502
43	C	?		-	-	17: U.18663	1, 133, 141	
44	C		skull only	-	U.18428	18: U.18520	16 (two)	
45	C	NW	on right side, legs tightly flexed	-	U.18445	9: U.18688; 13: U.18667 and another; 43 and frag- ments probably 23	111, 139	
46	C	?	no body visible	-	-	12: U.18468;	122, 158	
47	C	?	skull only	-	-	20: U.18578, U.18638		
48	B	?	no body visible	copper pin	-	20: U.18479	16, 25, 133, 152, 158	mat burial
49	C	NW	on right side; legs at acute angle with trunk, knees tightly flexed; hands before face	-	one carnelian ring	26: U.18603; 59: U.18672; 64: U.18593	133	
50	C	?	skull only	-	-	5: U.18591; 26: U.18519		
51	C	SE	on left side	-	-		4, 122, 133	
52a	C	SW	on right side; legs at obtuse angle with trunk, knees tightly flexed; hands before face	-	-	4: U.18677	16, 65, 152 16, 90, 121	
52b	C	SSE	on left side; body fairly extended	-	-	18: U.18668	122, 139 (two)	U.18668 probably does not belong
53	C			-	-	12: U.18669; 40: U.18471	16 (two), 20 (three), 59, 71, 111, 156 and fragments	obsidian flake, probably not belonging to the grave;

JAMDAT NASR PERIOD

54	C		on left side; fairly extended; hands before face	lead bowl JN.6	-	-	1, 16, 20 (nine), 61, 112 (four), 114, 139, 153 (three) 20, 65, 139							clay object, segment of circle, flat, with hole through it
55	C	?	not recognisable	-	-	6; 11: U.18518; 18: U.18666								
56	C	?	not recognisable	-	-	-	54, 121 (two), 122 (two), 133 122							
57	C	?	skull only	lead tum- bler JN.1	-	-								
58	C	?	not recognisable	-	-	20: U.18650; 21: U.18649; 22: U.18648	45 (two), 152							
59	C	SE	body fairly extended	-	-	8: U.18577; 20: U.18598; 23: U.18537	16 (two), 112 (five), 139, 156 20, 152							
60	C	?	skull, and traces of bone	copper pin or rod	-	-								
61	C	?		-	-	10: U.18642	25, 71, 93, 111, 156 and fragments of spouted jar of reserved slip ware 20, 59, 122 (two)							
62	C	NW	on right side; legs missing	-	U.18440	19: U.18446								
63	B	E	on right side	-	-	-	10							
65	C	N	on right side, legs at rt. angles with trunk, knees tightly flexed	-	U.18475	-	23, 104, 114, 122							mat burial
66	C	?	skull only	-	U.18439	-	16, 20, 55, 122, 133							
67	C	NNW	on right side; tightly contracted	-	-	-	16, 122 and two large jars, broken 112, 120 (painted), 153							
68	C	?	on right side; moderately contracted	-	-	-								
70	C	S	on right side, fairly extended	-	-	-	4, 111, 112							the bowl 4 inverted 0.30 m. above the body
71	C	?	no body visible	-	-	-	16 (four), 122, 156 and fragments 23, 61, 112							
72a	C	?	no body visible	-	-	10: U.18673; 27: U.18681								
72b	C	?	traces of bone only	-	-	21: U.18662; 30: U.18504	16 (five, 65 (two), 111, 112 (four), 133							probably not all one grave

## TABULAR ANALYSIS OF GRAVES

Grave No.	Period	Head direction.	Attitude	Metal	Beads	Stone Vessels	Pottery Types	Notes
73	B	SE	on left side; contracted	-	U.18483	8: U.18478; 61: U.18481	-	
74	C	NW	on left side	-	U.18465	23: U.18678; 59: U.18572	112	
75	C	?	on right side	-	-	5: U.18512	1, 23 (four), 112	
76	C	?	no body visible	-	-	11: U.18561, Pl. 34	16, 20, 25, 55, 112, 139 (two)	
78a	C	N & S	fragments of two bodies confused	lead tum- bler JN.1	-	50: U.18717	16, 17, 65, 100, 112, 122 (two), 141	
78b	B	?	only traces of bones	copper pin U.18461	-	-	99, 109	cylinder seal U.18463, Vol. X. No. 73
80	B	?	skull only	-	-	13: U.18509; 20: U.18548	20	U.18509 may not be- long to the grave
81	C	N	on left side	-	-	-	23, 112 (four)	
82	C	S	body decayed	-	U.18462	16: U.18480.	103 (six)	
84	C	SE	not recognisable	-	U.18475	4: U.18596; 14: U.18507; 19: U.18639 and three others; 22: U.18654	20, 111, 152, 153	
86	C	?	no body visible	-	-	10: U.18574	16 (two), 121 (two), 156, (one example of 121 is painted)	
87	C	NW	on right side, moderately contracted; v. Pl. 54	-	carnelian rings	18: U.18674; 50: U.18517	20 (two), 45, 103, 111, 122 (two)	bone button
88	B		fragments of skull only	-	U.18464	-	104	
90	C	ENE	on left side; v. Pl. 54	-	U.18459	10: U.18651; 13: U.18564; 35: U.18575, and miniature bowl and fragments of another	65 (painted red and burn- ished), 77, 104 (two), 111 (three), 153	a large cockle and cowrie shell
91	C	SW	on left side; v. Pl. 54	-	-	12: U.18671	20, 45, 56, 61, 111, 122	
92	C	?	not recognisable	-	-	4: U.18503	20, 111 (two), 122 (two), 141, 153	
93	C	?	skull only	-	U.18482	12: U.18592; 26: U.18559	16, 20 (ten), 61, 122, 152	cockle-shell containing pale green paint
94	C	?	not recognisable	-	-	17: U.18530; 21: U.18641; 27: U.18599	45, 61	
95	C	?	not recognisable	-	-	8: U.18511	158	
96	C	?	skull only	-	-	-	16, 86, 122 (two), and fragments	probably the remains of two graves

97	C	?	not recognisable	-	-	19: U.18540	45		
98	C	?	on right side	-	-	-	20, 45, 122		pierced clay roundel
100	C	S	on left side, tightly contracted; v. Pl. 54	-	U.18484	-	16 (three), 23 (two)		
101	C	?	skull only	-	shell rings	10: U.18516 and fragment of diorite bowl	139, 146		
102	C	SE	on right side; legs missing	-	U.18485	4	77, 100		
103	C	N	on left side; body decayed	-	-	-	146, 153 (with spots of red paint)		
104	C	S	on right side, knees tightly flexed	lead tumbler JN.1	-	5: U.18510; 24: U.18563	20, 32, 122 (two)		the lead tumbler may not belong
105	C	?	not recognisable	-	-	20: U.18549	86		
109	C	?	on left side, skull only	lead tumbler JN.1	-	16: U.18653	71 (three), and jar fragments		
110	C	SE	on right side, legs missing	lead tumbler JN.1	-	-	23 (two), 65, 112, 114		
111	C	?	skull only	-	U.18522	18: U.18541	16, 20, 39 (two), 104		
112	C	E	skull on right side, body decayed	-	-	-	112 (two)		
113	C	N	skull on right side, body decayed	-	-	25: U.18659	65		behind the skull a pot-base containing fine clean sand
116	C	N	on right side; v. Pl. 54	-	-	30: U.18539; 39 (fragments)	16 (four), 20 (four), 45, 111		U.18539 probably does not belong
118	B	S	not recognisable	-	U.18521	9: U.18562	23 (two), 111 (three)		
119	C	?	skull only	-	-	27: U.18679; 40: U.18524, with animals in relief, Pl. 31	122		
120	C	?	no body visible	copper pin	-	16: U.18543, U.18544	23, 100		
122	B	NW	on left side	-	-	1; 27: U.18560	20, and fragments of spouted jar		
123	C	?	on left side, moderately contracted	-	stalagmitic calcite cylinder	-	23, 122		
124	C	NW	on right side; v. Pl. 54	copper bowl JN.3 (?)	-	15: U.18633, and fragments of limestone bowl	32 (3-colour design), 111		
128	B	?	no body visible	copper pin	-	13: U.18604; 40: U.18601	104 (painted red and burnished)		

## TABULAR ANALYSIS OF GRAVES

Grave No.	Period	Head direction	Attitude	Metal	Beads	Stone Vessels	Pottery Types	Notes
129	C	?	skull only, on left side	-	U.18581	16: U.18631; 20: U.18630	16, 32 (U.18605, 3-colour design Pl. 26), 57, 104 (reserved slip), 122	
130	C	?	skull only, on left side	-	U.18580	19 (?) (fragments U.18634)	16 (two), 112	
132	C	NW	on left side, hands before face	-	-	fragmentary white lime-stone cup	23 (three), 122, 156	
133	C	SE	on right side, body decayed	-	-	4: U.18602	122	
135	B	E	skull only, on right side	-	-	4: U.18632; 9: U.18600	23 (four)	
136	C	N	on left side, body decayed	-	-	2: U.18583, decorated, Pl. 34	32, 86	
137	C	SW	on right side	-	-	9: U.18682; 16: U.18594	23, 146	
<u>IN PIT X</u>								
141	B	NE	on right side; the legs missing	-	-	10: U.19268; 57: U.19270	-	
142	B	NE	on left side; spine straight, knees close to trunk, tightly flexed; hands before face	-	-	19: U.19287, and fragments	-	
143	C	E	on left side; spine straight, legs at rt. angles to trunk, knees tightly flexed; hands before face	-	-	-	33: U.19298	matting under the body; the vase by the elbow
144	B	NW	on left side; spine straight, legs at rt. angles to trunk, knees tightly flexed; hands before face	-	-	56: U.19263, Pl. 34	6, 20	also the base of a large pot used as a saucer; mat burial
145	C	NNW	spine straight, legs at rt. angles to trunk	-	-	16: U.19278; 55	-	mat burial, disturbed
146	C	NE	on right side, legs at less than rt. angles to trunk, lower legs missing	-	-	7: U.19294	134	

147	B	NE	on left side, legs at slightly more than 90°, knees tightly flexed	-	-	28: U.19285	-	mat burial
148	C	SE	on left side, legs at right angles to trunk, knees very tightly flexed	-	-	16: U.19288 and fragments	20, 23, 64 (red burnished ware)	mat burial
149	B	SE	on left side, legs disturbed	-	U.19254, Pl. 27	-	140	mat burial
150	C	W	legs at rt. angles to trunk, knees tightly flexed	-	-	9: U.19265, Pl. 34; 20: U.19284	19, 20, 43, 140	mat burial
151	C	NE	on right side; spine bent, legs at obtuse angle to trunk, knees tightly flexed, hands before face	-	-	29: U.19280	23 (two), and a pot	mat burial
152	C	NE	on right side, spine bent, legs at obtuse angle to trunk, knees flexed, hands before face, v. Pl. 54	-	-	15: U.19301; 24: U.19300; 56, and another bowl	23, 96 and fragments	mat burial
153	B	NE	on left side; body and legs disturbed	-	-	24: U.19299	140	mat burial
154	C	NW	on left side; spine sharply curved, position of legs not clear	-	a few lapis	4: U.19260, U.19282; 12: U.19315; 21: U.19289; 22: U.19266; 24; 57: U.19279; and a rectangular limestone trough	19, 23, 96, 117 and fragments	mat burial; the vessels were in two groups, at the head, and at the foot of the grave in front of the legs; the grave was disturbed; two halves of the same bowl lay 2.00m. apart; there was also a large shell
155	C	SW	bones almost entirely decayed	needle (?)	U.19255	25: U.19267; 57: U.19286	23 (two), 96 (red ware with haematite wash)	mat burial; one tumbler was in the mouth of clay vase 96; a conch shell cut open as a lamp
156	B	NNW	on left side; spine curved, legs at sharp angle to trunk, knees very tightly flexed, hands before face	-	-	8: U.19318; 24: U.19290	23, 140	mat burial; the vessels were placed behind the head

## TABULAR ANALYSIS OF GRAVES

Grave No.	Period	Head direction.	Attitude	Metal	Beads	Stone Vessels	Pottery Types	Notes
157	C	SE (1) and SW (2)	(1) on left side, spine straight, legs at obtuse angle to trunk, knees tightly flexed, hands before face (2) on right side, spine tightly curved, legs at obtuse angle to trunk, knees tightly flexed, hands before face; <i>v.</i> Pl. 54	Copper bowl JN.2	—	8: U.19295; 24: U.19296; 45: U.19302; 57: U.19274	116, 140 (two)	the bodies lay one above the other but the bones were in such a condition that it was hard to say which was on top
158	C	SW	bones too decayed for attitude to be seen	—	U.19248	30: U.19261	21 (two)	mat burial; a large shell
159	B	NE	on left side, spine straight, legs at sharp angle to trunks, knees tightly flexed	—	—	24: U.19303; 57: U.19275 and fragments of another bowl	23 (set in the mouth of the stone vase 57)	the bodies, one above the other with no earth between; perhaps con-temporary; the pots might belong to either or both
159b	B		at a slightly lower level but perhaps part of the same grave	—	U.19247 and a few long shells Pl. 27	57: U.19277 and a miniature of the same type	—	
160	B	NE	disturbed; a child's bones	—	—	20: U.19317; 21: U.19262; 23: U.19281; 24: U.19264	37	the stone vessels 20 and 23 lay apart and may not belong to the grave
161	C	NE	on right side; a child's bones	—	U.19250, Pl. 27	12: U.19292; 23	23, and fragments	mat burial
162	C		some small animal bones under the inverted bowl; no human bones left	—	U.20065	8: U.19276	33 (black clay U.19551), 96, 97	the pots lay against a large bee-hive shaped bowl ht. 0.30 m. which was inverted in the soil
173	C	NE	on right side; spine straight, legs at rt. angles to trunk, knees tightly flexed	—	—	8 (two); 12: U.19307; 28; 52: U.19306	48, 74, 139, 140	mat burial
174	B	N	bones almost completely perished	—	—	4; 15: U.19398; 28; 59	96	mat burial



175	B	SE	on left sides, spine sharply curved bringing knees to 0.35 m. from face	-	-	10; and a limestone bowl perished	105	mat burial
176	B	NW	body too fragmentary to give attitude	-	-	19: U.19344; 35	140	mat burial
177	B	B	only the broken skull left	copper bowl, JN.6; razor U.19497	-	4; 24: U.19312	140	
178	B	B	no body	-	-	-	138	a clay bowl ht. 0.30 m. diam. 0.70 m. with ribbed sides, inverted; the vase alongside it
179	B	NE	on left side, much decayed	-	U.19251, Pl. 27.	4: U.19331; 59, miniature	-	mat burial; a conch shell cut open; the beads were scattered over the body
180	B	NW	on right side, not much flexed	-	-	4: U.19308; 12	23 (two), 116, 140	mat burial
181	B	NW	on right side, lower limbs missing	-	-	26: U.19314; 59	81, 104	mat burial
182	C	NW	on right side; v. Pl. 55.	-	-	1: U.19304; 24; 27: U.19343; and another diorite bowl (fragments)	47, 116, and base of a very large jar	mat burial
183	C	NW	on right side, much decayed.	-	-	15; 27	116, 140	mat burial
184	B	NE	the body not recognisable	lead tumbler JN.1, copper bowl decayed	-	26	140, and remains of pot with haematite wash	mat burial
185	B	?	not recognisable	copper bowl, JN.2	-	-	140	
186a	C	SW	on left side, spine straight, legs at sharp angle to trunk, knees tightly flexed	-	-	8: U.19340; 12	116, 117	mat burial
186b	B	NW	on left side, legs at acute angle to trunk	-	-	12: U.19325, U.19380; 49: U.19323	116, 140	
187a	B	NW	on right side, legs at obtuse angle with trunk, knees tightly flexed	lead tumbler JN.1	-	12: U.19327	62, 140	

## TABULAR ANALYSIS OF GRAVES

Grave No.	Period	Head direction	Attitude	Metal	Beads	Stone Vessels	Pottery Types	Notes
187b	B	NE		-	-	8; 12; 15: U.19451; 23	20, 62, 116, 140 (two)	mat burial; the remains of several bodies lay so close together that no one grave could be properly distinguished; the pots may not all be long together, but are contemporary
188	B	SW	on left side, v. Pl. 9,b	-	U.19257	9: U.19319, Pl. 32; 23: U.19336; 24: U.19322; 50: U.19342; 57: U.19328	104, 140 (two)	mat burial; at 0.30 m. above the body was a clay bowl ht. 0.17 m. diam 0.56 m. inverted; in it, infant's bones.
189	B	SE	on left side	copper bowl (?), copper bidens U.19246	-	12: U.19450; 24: U.19330	-	mat burial
190	C		only the skull left	-	U.19259	24: U.19326 and another; 59	21, 104 (three), 140	mat burial
191	B	W	on right side, v. Pl. 55; body of a young girl	-	shell and carnelian rings	8; 10: U.19383; 22: U.19324; 24, and fragments of another bowl	60, 123, and fragments	
192	A	NW	on right side	-	-	12: U.19394	46, 121	mat burial
193	B	N	on left side	copper bowl, remains of	-	4: U.19347, U.19463; 8: U.19393 and fragments; 24: U.19463 and another	104, 140, fragments of jar with red paint wash, burnished	
194		SW		copper bowl, JN.4; lead tumbler JN.1	-	9: U.19341; 39: U.19338; 48: U.19382	-	mat burial; only the stone bowl 9 necessarily belongs to the body
195	B	NW	on right side, not strongly flexed	-	-	8; 22	104, 116 (two), 137	mat burial
196	B	NE		lead tumblers 2, JN.1	-	24	138	
197	C	NE		-	U.19256	9: U.19373; 10: U.19469; 22; 24: U.19329; 49: U.19374; 50: U.19321; 64	20, 23, 152	

198	B	N	on left side; spine curved, legs at acute angle with trunk	-	U.19233	8: U.19332; 13; 15; 20: U.19369; 40: U.19337; and a limestone bowl, crushed	20, 123	mat burial
199	B	SSW	on right side; legs at obtuse angle with trunk, knees very tightly flexed	-	-	9: U.19367; 10; U.29467; 13: U.19356, Pl. 32; 50: U.19381 and another	60, 116 (three), 138 (four)	mat burial
200	B	NW	on right side	copper pan JN.4 (?)	-	19: U.19363; 39: U.19387	-	-
201	B	NW	on right side, legs at rt. right angles with trunk	copper bowl JN.3	U.19232, Pl. 27	8: U.19371; 13: U.19360, and remains of limestone bowl	138	in the copper pan was the lower jaw-bone of an animal
202	B	NE	on right side	copper bowl JN.3 (?)	-	-	-	mat burial
203	B	SW	on left side	-	-	24 (two)	104	-
204	B	SE	on right side, v. PIs. 9, c and 55	2 lead tumblers, JN.1	U.19231	12; 24: U.19353, U.19354; U.19359, and two others	20 (three), 60, 62, 115 (six), 140	-
205	C		not recognisable	-	-	4: U.19375 and another; 8; 10: U.19386; 13: U.19392 and another	20, 21, 60, 116 (two)	the bone remains may represent more than one body
206	B	SW	on right side	lead tumbler JN.1	-	24: U.19368, U.19397; and another	20, 37, 111, 138, 140	mat burial
207	A	NW	on right side, v. Pl. 55	lead tumbler JN.1	-	-	20 (four), 23, 60, 129, 139, 140	-
208	A	?		copper bowl, remains of	-	19: U.19385	23 (seven), 111 (two) pot of reserved slip ware	no body; the vessels probably belong to one grave
209	A	NW	on left side; legs at acute angle with trunk, knees tightly flexed	-	-	8: U.19364	reserved slip ware, fragmentary, 124	mat burial
210	A	N	on left side, v. Pl. 55	copper bowl, JN.2 (?)	U.19237, Pl. 27	12: U.19355; 45: U.19399; lamp, U.19885, Pl. 32; pedestal lamp U.19593, Pl. 33	121, 136	-
211	A	?	only the skull left	-	-	24: U.19370; 40: U.19378 (decorated, Pl. 31)	124, 138	the vases were touching the isolated skull
212	A	SW	on left side, body decayed	-	-	-	-	mat burial
213	A	SE	unrecognisable	-	U.19234	4: U.19362	53	mat burial

## TABULAR ANALYSIS OF GRAVES

Grave No.	Period	Head direction	Attitude	Metal	Beads	Stone Vessels	Pottery Types	Notes
214	A	?	bones in confusion	-	-	4: U.19358	144, fragments of red burnished pot 30, 37, 44	mat burial; shell U.19448; the pot 37 was originally painted, 3-colour ware but the paint perished.
215	A	SE	on right side	fragment	-	-		
216	A	?	bones in confusion	-	U.19235	-		
217	A	NW	on right side	-	-	8: U.19388	23 (sixteen), 113 (red burnished), 123 (reserved slip ware), and fragments	mat burial
218	B	NW		-	lapis, crystal and carnelian U.19444	24: U.19389; 59: U.19384		mat burial; conch shell cut as a lamp
219	C	SW	on right side; legs at rt. angle with trunk, knees tightly flexed	silver ear rings, U.19444	U.19435 U.19431	57: U.19400		mat burial
220	C	NW	on left side, v. Pl. 55	copper tum- bler JN.1, small copper spoon, U.19937	U.19435 U.19431	1: U.19404; 6: U.19403, U.19436, Pl. 32; 31: U.19402, Pl. 33; 57: U.19401, Pl. 33, U.19405, U.19406, U.19407	87, 105	mat burial
221	B	NW	only faint traces of bones lying under some of the pots, the body on its right side	2 copper bowls (remains of), 2 copper pins	U.19575 Pl. 27, U.19576, U.19571	9: U.19520; 10: U.19516; 15: U.19532; 24: U.19565; 28: U.19415, Pl. 32; 31: U.19554; 32: U.19408; 40: U.19594; 42: U.19562, U.19563; 51: (variant) U.19515; 56: U.19409, U.19410, U.19411, U.19412, U.19413, U.19414 (Pl. 32), U.19529 (Pl. 31), U.19533, U.19564; 57: U.19518 Pl. 34, U.19521, U.19526, U.19527, U.19528; 62: U.19517,	20 (two), 105, 140 (three)	mat burial

221 (cont'd)	B	?	not recognisable	-	-	Pl. 34; 63: U.19519, Pl. 33	140	mat burial
222	B	SE		-	-	4: U.19421; 24: U.19419		
223	B			-	-	3: U.19417, Pl. 33, U.19418		mat burial
224	?	?	position doubtful	fragmentary copper bowl (?)	-	24: U.19530, U.19531		mat burial
225	C	NW		copper bowl, remains of	U.19570	24: U.19522, U.19525; 57: U.19523, U.19524	37 and fragments	mat burial
226	B	SW		-	carnelian ring and cylinder	24: U.19422, U.19423; 59: U.19416		mat burial
227	B	NW		-	-	24: U.19500; 57: U.19424		only part of grave area preserved
228	B	?	not recognisable	-	-	8: U.19503; 24: U.19502		mat burial
229	C	?	not recognisable	copper bowl (?)	U.19577 and a few carnelian rings	1: U.19510; 24: U.19512; 29: U.19513, Pl. 34	87	mat burial, but probably two or three confused together
230	C	NW	on right side, (only upper part preserved)	-	-	8: U.19506; 13: U.19507; 24: U.19504; 57: U.19505	138	mat burial; a second skull lay touching the first, the body lying with head SW; some of the objects may belong to this
231	B	NW	body in confusion	-	-	24: U.19545, U.19546, U.19547 and another; 30: U.19548 and lime- stone bowl	117, and rim of a large pot painted red and burnished	mat burial
232	C	SW	on right side, legs at acute angle with trunk, knees tightly flexed	-	U.19598	8: U.19589; 12: U.19588	20, 140	mat burial
233	C	NW		-	-	57: U.19586 and lime- stone bowl	139	
234	B	NE		-	-	9: U.19580; 24: U.19581; 27: U.19582; 31: U.19583		
235	B	?		-	-	8: U.19587; 57	fragments of red-painted burnished pot	
236	B	SW		-	U.20026	8 (fragmentary); 18: U.19599; 25: U.19604		

## TABULAR ANALYSIS OF GRAVES

Grave No.	Period	Head direction	Attitude	Metal	Beads	Stone Vessels	Pottery Types	Notes
237	B	NW	on right side	-	-	23: U.19606; 57: U.19607	111	
238	B	?	bones all gone	-	shell cylinders & haemite rings & small natural shells	8: U.19605, U.19608; 19: U.19611; 24: U.19609	20	
239	C	W	on left side; legs missing	silver ear-rings U.20037	shell rings U.20036	42: U.19610	74, base of pedestal vase, of RC. 240, painted pot U.20040, Pl. 26	mat burial; the shell rings decorated a belt; two cockle shells with black paint
240	B	NW	on left side	-	-	10: U.19613; 59: U.19612	fragments	mat burial
241	C	SW	on right side	-	-	12: U.19632; 24: U.19633	67, smooth greenish drab ware	mat burial
242	B	E	on right side	-	-	8: U.19627; 14: U.19626; 40: U.19629; 52; 57: U.19625; 59: U.19623	20, 140	mat burial; conch shell cut as lamp
243	B	E		-	-	1: U.19635; 4: U.19637; 24: U.19636	20, 140	mat burial
244	C	SW		-	U.20066	24; 28	20, 123, 137	mat burial
245	C	NW	on left side	-	-	27: U.19621; 57: U.19620, U.19622; and alabaster miniature vase U.19619	20, 140 and fragments	mat burial
246	B	N	on left side	-	-	12: U.19641; 31: U.19642; 51: U.19618; 59: U.19640A, B, C	20 (three), 117 (two), 140	mat burial
247	B	?		-	-	24; 59; lamp U.19643	-	
248	C	?		-	-	24: U.19650, U.19651; 32: U.19653; 59: U.19649	140	
249	C	?	only fragments of bone	-	-	10: U.19648; 30: U.19646; 59: U.19647	140	mat burial
250	C	?		-	-	9: U.19645; 13: U.19644	140, pot of creamy clay once covered with red paint	mat burial
251	B	SW	on left side	-	U.20089	12: U.19654; 20: U.19680; 24: U.19681; 57: U.19655	20, 117 (two)	

252	B	?	only traces of bone left	-	-	28: U.19683; 36: U.19682; 52: U.19684	20	at 0.30 m. above the grave was inverted a clay bowl Type 5, ht. 0.24 m., diam. 0.46 m. perhaps connected with the grave
253	B	?		-	U.19868	22: U.19686	20	mat burial
254	B	SW		-	-	17: U.19688; 24: U.19689, U.19687		mat burial
255	B	NE		copper bowl (?)	-	4: U.19701; 24: U.19703; 57: U.19700, and fragments U.19702	140	mat burial
256	B	?		-	U.19858	14: U.19716	6, 140	
257	B	SE(?)	only fragments of skull left	-	-	20: U.19719, U.19718; 52: U.19717, and fragments		
258	B	E	not recognisable	-	-	1: U.19659; 8: U.19706; 24: U.19658, U.19707		
259	B	NW	legs at acute angle with trunk, knees tightly flexed	-	U.19859	18: U.19704; 24: U.19705; 57: U.19750		
260	B	NW	body and legs nearly straight, knees flexed at right angles	-	-	12: U.19752; 57: U.19753	20, 104, 105	
261	B	E	not recognisable	-	U.19861	30: U.19756; 57: U.19758; 59: U.19757		shell cut as a lamp
262	B	SW	not recognisable	-	lapis rings and carnelian cylinders	8: U.19763		shell cut as a lamp
263	B	NW	body closely flexed, knees almost touching the skull	lead tum- bler JN.1	-	52: U.19765	140	
264	B	?		-	-	12: U.19721; 13: U.19720; 14; 20; 24: U.19723 and another; 40: U.19722	20 and fragments	remains of 3 mat burials confused together
265	A	SE	on left side, legs at acute angle with trunk, knees tightly flexed	-	-	9: U.19725; 24: U.19726, U.19730; 29: U.19724; 57: U.19727	98, 140	mat burial
266	C	SE	on left side, v. Pl. 55	-	U.19864	24: U.19728, U.19731	20 (three), 87, fragments	mat burial
267	B	W	on right side	-	-	4: U.19733, U.19734		mat burial

## TABULAR ANALYSIS OF GRAVES

Grave No.	Period	Head direction	Attitude	Metal	Beads	Stone Vessels	Pottery Types	Notes
268	B	E	on right side	2 copper bowls JN.6	-	8: U.19735; 24: U.19736	20 (three), 140	mat burial; only part excavated
269	B	NW	body destroyed	copper fish-hook U.19875	U.19865	11: U.19739; 39: U.19737; and another limestone bowl	9, 60	mat burial
270	B	?	only the skull left	lead tumblers JN.1	-	24: U.19740; 28: U.19741	140	shell cut as a lamp
271	B	NE	on left side, legs slightly flexed	-	-	19: U.19742; 24: U.19743 and another; 52	116	
272	C	?		-	-	10: U.19748; 16: U.19746, U.19747; lamps U.19744, Pl. 31, 32, U.19745, Pl. 32; limestone disk U.20080	20, 61	only part of the grave excavated; shell cut open as a lamp
273	?	?	not recovered	-	-	25: U.19772; 57: U.19771; 64: U.19770, Pl. 32	-	mat burial
274	C	?	not recognisable	-	-	24: U.19806 and another; 48: U.19807; half a pear-shaped limestone mace-head; a stone rubber	33: U.19955 (in greenish clay Pl. 25), 61	mat burial
275	B	NW	on right side, v. Pl. 55	-	-	24: U.19808, U.19809, U.19810, and another	20 (two), 111	mat burial
276	B	SE	on left side	-	U.19853	41: U.19811	137	mat burial
277a	A	SE		-	-	15: U.19777	20 (two), 126	mat burial
278	B			-	-	4: U.19776; 57: U.19779	116 (two)	mat burial
279	B	S	on left side, legs at right angle with trunk, knees tightly flexed	-	U.19862 U.19867 and large shell ovals	24: U.19749, U.19773, U.19774	20	mat burial
279a	B	N	on right side, legs missing, hands before face	-	U.19862 U.19867 and large shell ovals carnelian tubes	22: U.19804; 24: U.19803; 41: U.19802; 52: U.19801; lamp U.19805	20	shell cut as a lamp
280	C		skull only left	-	-	8; 15: U.19766; 44: U.19767	20, 43, 140, bowl 8 inverted over the skull	
281	A	NW	body destroyed	copper bowl copper pot	-	12: U.19783; 24: U.19782 and 2 others	20, 53, 73	the head rested in the copper bowl



282	A	SE	on right side	—	—	15: U.19784; 24: U.19785, U.19788; 26	136		mat burial
283	B	NW	on right side	lead tumbler JN.1	U.19851	10: U.19790; 14: U.19791, U.19793A; 20: U.19792; 24: U.19789	60, 73, fragments (of 140?)		mat burial
284	B	SW	on right side	lead tumbler JN.1	U.19855	8: U.19786	20		mat burial; beads 19855 at waist, 19856 at neck
285	B	N	on left side	—	U.19856	1: U.19815; 24: U.19814	20		mat burial
286	B	SW	on left side	—	camelian ring	18: U.19816; 52: U.19817	20		mat burial
287	A	NW	three bodies; two lay with their heads NW	—	U.19850 (at waist)	5: U.19824; 9: U.19819; 16: U.19821; 17: U.19820; 24: U.19822, U.19825; 48: U.19823; 'table' U.20056, Pl. 33	46, 73, 105, 123 (two)		
288	A	NW	on left side, legs at right angles with trunk, knees tightly flexed	lead tumbler JN.1	—	15; 20: U.19794; 24: U.19793; 59 (miniature)	38, 62, 89		mat burial; cockle-shell
289	B	N	legs at right angles with trunk, knees tightly flexed	—	—	4; 12: U.19829, U.19831; 41: U.19832; 43: U.19830; 57: U.19828	—		mat burial
290	B	S	not recognisable	—	—	12: U.19833, U.19835; 24: U.19834, U.19837; 57: U.19836	—		
291	B	NW	on left side, legs missing	—	—	19: U.19838, U.19839	73, 104		
292	C	S	on left side, spine sharply curved, knees tightly flexed, hands before face	lead tumbler JN.1	—	4: U.19842; 24: U.19844; 52: U.19843	87		
294	A	SE	spine sharply curved, knees tightly flexed	copper bowl, copper vessel, lead tumbler JN.1	—	14: U.19846, U.19845	124		
295	B	?	not recognisable	—	U.19971	4: U.19882; 8: U.19884; 9: U.19883; 15: U.19881; 16: U.19886; 28: U.19880; 41: U.19847; 48: U.19887	89, 111		mat burial
296	B	NE	not recognisable	copper bowl	U.19945	19: U.19879; 20: U.19797; 22: U.19878; 26; 27: U.19877; 32: U.19848	—		
298	B	SW	on left side	—	U.19944		23, 105 (two)		mat burial

## TABULAR ANALYSIS OF GRAVES

Grave No.	Period	Head direction	Attitude	Metal	Beads	Stone Vessels	Pottery Types	Notes
299	B	NW	on right side	-	-	48: U.19906	23 (ten), 111 (two), 116, and fragments 140	shell cut as a lamp.
300	B	NW	on left side, hands before face, legs missing	-	U.19943	15: U.19888		
301	C	NW	on right side, spine strongly curved, knees tightly flexed, hands before face	-	U.19951	9: U.19890; 28: U.19889; and a limestone bowl	56	
302	B	NE	not recognisable	-	-	9: U.19924; 52: U.19891; 57: U.19925	20, 104, 123 (two)	
303	C	NW	knees tightly flexed, hands before face	-	-	17: U.19926	33 (burnished black ware)	
304	C	S	legs missing	-	-	-	8, 20, 105, 116 (two), 123, 152	
305	A	SW	not recognisable	lead tumbler JN.1, copper spoon U.19937	U.19946	4: U.19898; 10: U.19899; 24: U.19900; 52 (?): U.19901	53, 60	
306	A	NW	on right side	-	-	4: U.19912; 24: U.19908, U.19909; 35: U.19907; 53	20 (six), 123, 136 (three)	mat burial.
307	A	SW	on right side	-	-	24: U.19910	136, 140	the stone bowl does not necessarily belong to the grave.
308	B	NW		-	-	22; 57: U.19911	-	
309	C	NW	on left side, legs missing	-	U.19950	20: U.19914, U.19918, U.19919; 23: U.19915, U.19916; and a crushed bowl	61 (U.20057, of black-grey clay Pl. 25)	
310	A		only skull left	-	-	8: U.19917	6, 98, 129, 144	
311	C	NE	not recognisable	lead tumbler JN.1	U.19942	20: U.19921, U.19922; 23: U.19920; 24	20, 33 (slate-coloured clay), 38, 137	
312	A		no bones visible	-	-	7: U.19935	20 (several), 111 (five), 129 (two)	
313	A		only skull left	-	camelian rings	22: U.19936	111, 129	
313a	A		not recognisable	-	-	U.19949	20, 23 (three), 31 (red painted), 38, 105, 129	

314	B	not recognisable	lead tumbler JN.1	-	14: U.19930, U.19931; 15: U.19892	20, 116, 123, 138
315	B	only skull left	-	camelian ring and two lapis tubes	20: U.19939	23, 123 and fragments of several large pots
316	B	only skull left	-	-	20	6 (two), 38
317	A	only skull left	-	-	-	38: U.19981, painted, Pl. 25; 48: U.19980, red- painted, Pl. 25; 144 (greenish drab clay)
318	A	no bones visible	-	-	4: U.19955; 10: U.19800	20, 84, 101, and fragments and four large pots
319	A	SE	-	-	24: U.19962	-
320	A	SE	lead dish JN.4	-	35: U.19963, Pl. 32	23 (sixteen), 129
321	B	on right side, closely contracted	-	-	14: U.19964; 20: U.19965; 24: U.19966; 44: U.19967	-
322	B	on left side, legs at right angles with trunk, knees tightly flexed	-	U.19972	24: U.19969	-
323	A	on left side, closely con- tracted	-	U.19973	24: U.19956	-
324	A	fully extended, the legs in a straight line with the body, hands before face	-	U.19974	4	-
325	A	mat coffin, v. Pl. 8, b	lead tumbler JN.1	camelian and lapis tubes	20: U.19960; 52: U.19961, Pl. 32	48, 104, 111 (three), 124, 126 (red painted ware)
326	A	no bones visible	-	-	-	30, 38: U.19979 (red painted)
327	B	W	-	camelian rings and date- shaped and some lapis	24: U.19988	-
328	B	body decayed	-	-	12: U.19990	38 (grey clay), Pl. 25
329	A	body mostly decayed, v. Pl. 9, d	-	-	8: U.19991; 14	111 (two), 129, 137 (three)
330	A	on left side, closely con- tracted, v. Pl. 9, d	-	U.20028	20: U.19994; 24: U.19995; 40: U.20000 with bull relief, Pl. 31	105 (two, one with reserved slip), 111 (three), 129

stamp seals, U.19974,  
U.19975, Vol. X, Nos.  
5 and 6

mat burial

Grave No.	Period	Head direction	Attitude	Metal	Beads	Stone Vessels	Pottery Types	Notes
331	A	NW	body mostly decayed, v. Plate 9, d	-	-	12: U.19992; 19: U.19993; 22: U.19997; 24: U.19996	67, 105, 117 (thirteen), 129	mat burial
332	A	?	V. Plate 9, d	lead tumbler JN.1	-	U.20008	36 (3-colour decoration), 60, 111, 116, 136	several contemporary graves confused
333	A	?	V. Plate 9, d	lead tumbler JN.1	-	24: U.20007	111 (three), 144, 129	
334	A	NW	V. Plate 9, d	-	U.20030	-	104, 124, 138	mat burial
335	B	NE	on left side	lead tumbler JN.1	U.20029	18: U.20001; 20: U.20002	fragments	mat burial
336	A	W		-	carnelian rings	4, 24	20, 104, 136, 137, 138	
337	A	SW	body all decayed	-	U.20027	5: U.20005; 8: U.20006; 11: U.20004	20, 105, 124	two clay sling-bolts
338	A	NW	not recognisable	lead tumbler JN.1	U.20033	9: U.20012; 14: U.20015; 15: U.20013; 24: U.20014	20, 23 (ten), 116 (two), 12, 124	
339	B	W		-	U.20032	24: U.20016	23 (fourteen), 111 (three)	
340	A	E	on left side, v. Pl. 55	-	-	16: U.20017 and a diorite bowl	6, 73 (U.20040, 3-colour decoration), 73 (painted), 79, 111 (five)	
341	B			-	-	39: U.20018, U.20019	111	pebble hammer-head
342	A	NE	body all decayed on left side	-	-	16: U.20022; 17: U.20020; 24: U.20021	129	
343	A		body all decayed	lead tumbler JN.1, copper bowl (?)	-	17: U.20023 and another	62 (U.20025, 3-colour decoration), 98, 111 (three)	
344	A	NW	little more than skull left	-	-	diorite bowl	20 (several), 23 (several), 37, 104, 111, 144	
345	A	NW	on right side	-	-	-	106	mat burial
346	A		no bones left	-	-	-	14, 48 (U.20024, 3-colour decoration, Pl. 26), 101	the cup 14 probably does not belong to the grave
347	A	N	on right side	-	carnelian and lapis rings and lapis tubes	4: U.20032, U.20033, U.20034	44, 88, 98, base of large pot with haematite wash	

IN PIT Y												
348	B	NE	body contracted.	—	—	—	—	—	—	—	51	
349	A	NW	on left side, body contracted	lead tumbler JN.1	carmelian rings	U.14490a, U.14491a, U.14492a	3: U.14459a 10: U.15126; 16: U.15124; 34: U.15133; 44: U.15125	46, 73, 91, 104, 117, 119, 125, 135	grave at 0.90 m. below SIS 6-7			
350	B	NW		—	U.14498a	9: U.14493a		92				
351	C	W	on left side	—	—	9: U.14496a; 26: U.14494a, U.15120; 28: U.14497a; 54: U.14495a		27, 45	the clay pots 27, 45 may not belong			
352	B	?	on right side, body contracted	—	—	27: U.14499a		—				
353	B	SW	on right side, body contracted	—	U.15106 U.15108	54: U.15101, and fragments of 3 bowls 17: U.15122		35, 75	shell cut as a lamp			
354	B	SW		—	—	10: U.15110; 54: U.15109, U.15111		—				
355	B	W	on left side, body contracted	—	—	12: U.15112; 13: U.15114, U.15115, U.15117; 14: U.15116; 17: U.15118; 26: U.15113		—				
356	B	S		—	—	36: U.15121		54, 148				
357	B	S	on right side	—	—	26: U.15135; 28: U.15134		—				
358	B	NW		—	—	37: U.15127		—				
359	C	S		—	—			6, 23, 74, 77, 137, and fragments of 3 more spouted jars				
360	C	W	on left side, body contracted	—	U.15119			60, 63, 110, 137				
361	A	SW	on right side, spine straight, legs almost straight with the trunk, knees tightly flexed, hands before face	—	—			—				
362	A		on right side, body contracted	lead tumbler JN.1, copper mirror U.15164	—	16: U.15165		28 (three), 63, 95 31, 56	mat burial			
363	C			—	—							

Grave No.	Period	Head direction	Attitude	Metal	Beads	Stone Vessels	Pottery Types	Notes
364	A	NE	on right side	lead tumbler JN.1	-	-	26, 58, 62, 110 (two), 135 (two) fragments	
365	B		body disturbed (?), the skull under the pelvis	-	-	12: U.15160	-	
366	B		on right side, only slightly contracted	-	-	-	-	
367	C		on right side, spine straight, legs at angle 45°, knees flexed, hands on pelvis	-	-	21: U.15169	56, 81	
<u>IN PIT Z</u>								
368	C		on right side, body tightly flexed with heels against pelvis	-	-	U.14917	21, 90	mat burial
369	B		no trace of body	-	-	5: U.14914	130	
370	B		a few bones in bad condition	-	-	19: U.14915	-	

## APPENDIX IV a

TABULAR ANALYSIS OF THE GRAVES OF THE ROYAL CEMETERY PERIOD FOUND IN PIT X

Grave No.	Type	Direction	Metres above sea level	Gold	Silver	Beads	Cylinder Seals	Metal Tools and Weapons, etc.	Copper Vessels	Pottery Vessels (R.C. Types)	Stone Vessels (R.C. types)	Varia and Notes
B.1	L	NW x SE Head NW	8.80					axe 3a				
B.2	T	NW x SE Head NW	9.20			U.19014		pin			U.19016: 16a; U.19009: 92	
B.3	T	N x S Head N	9.20			U.19012	U.18999	pin 1; pin; axe A2; ring U.19012	bowl U.19025; bowl	108, 145	U.19011: 54; U.19010: 92	
B.4	T	NW x SE Head NW	9.80			lapis car- nelian and paste U.18996		pin 1				
B.5	T	NE x SW Head SW	10.00			U.18990		pin 2a; ear rings				frog amulets
B.6	T	NE x SW Head NE	10.00		ear rings		shell, decayed	pin 2a; reticule		53	U.18991: 37a	
B.7	L	NE x SW Head SW	9.60					pin 2a		108		
B.8	T	NW x SE Head NW	9.30					3 pins 2a		5a, 108 (2)	U.18992: 109	2 cockle shells with paint
B.9	T	NE x SW Head NE	9.30		hair ring			axe 56; pin 8; 2 arrow heads 1b pin 2a	bowl	7b, 108		cowrie shell
B.10	T	NE x SW Head SW	10.00							5a, 108 (3)		
B.11	T	NW x SE Head NW	8.80			4 lapis and carnelian double conoids		axe; axe A1		108 (2)	16A	

Grave No.	Type	Direction	Metres above sea level	Gold	Silver	Beads	Cylinder Seals	Metal Tools and Weapons, etc.	Copper Vessels	Pottery Vessels (R.C. types)	Stone Vessels (R.C. types)	Varia and Notes
B.12	T	NE x SW Head SW	8.60				shell decayed	knife 3; pin 2a; 2 headed pin U.19020	bowl		U.19023: 107	
B.13	T	NW x SE Head NW	9.00			U.19044	shell decayed (large); shell decayed (small)	knife 7a; pin with lapis ball head				conch shell cut as lamp; 2 cockle shells with paint
B.14	L	NW x SE	8.80			2 large lapis faceted dated shaped heads			2 copper pans (scales?)		U.19017: 54	
B.15	L	NW x SE Head NW	8.60					axe A; knife	bowl			
B.16	L	N x S Head N							bowl		U.19024: 41	
B.17	L	NW x SE Head NW	8.40					ear ring; pin 2a	bowl	60, 108		
B.18	T	NE x SW Head NE	7.90					adze I	copper strainer & bowl		U.19067: I	
B.19	L	NE x SW Head SW	8.20			U.19027						
B.20	L	E x W Head W	8.20									
B.21	T	NE x SW Head SW	8.20				shell decayed	chisel 2a, U.19029; saw; pin		108 (2)	U.19041: 42	2 conch shells cut as lamps conch shell as lamp U.19038
B.22	L	NW x SE Head NW	8.20			lapis, carnelian		pin with lapis ball head	bowl 3			
B.23	L	NW x SE Head NW	8.20					adze 1 U.18998; knife 7c				
B.24	T		7.90			lapis, carnelian		pin 7 with metal head				
B.25	T	cf. PJ/ G.162	9.60				shell decayed	axe A1; 2 pins				



ROYAL CEMETERY PERIOD

B.26	T	NE x SW Head NE	9.40		beads	U.19030	shell, decayed	axe A3; pin with lapis ball head	U.19050: 80 limestone rec- tangular trough	
B.27	T	NW x SE Head NW	7.60					pin	U.19049: 61a; U.19095: 16b; U.19136: 47	conch shell cut as lamp with bird's head
B.28	L	NE x SW Head SW	7.60				lapis U.19072 Vol. X, No. 120	pin (broken)	U.19063: 60b	
B.29	T		9.30		1 ear ring	U.19054		pin 2a	U.19062: 60b	
B.30	L	NE x SW Head SW	7.50	1 bead		2 lapis, 1 gold on head	shell U.19040 Vol. X, No. 142	axe A1; dagger 7c		
B.31	T	NW x SE Head NW	9.20					axe A1; knife; axe		
B.32	T	NE x SW Head NE	9.30		finger ring, beads	U.19074		pin lapis ball head	U.19060: 62	
B.33	T	NE x SW Head SW	9.30		beads	U.19053	shell de- cayed, shell crystal	3 pins lapis ball head; knife	U.19058: 92; U.19083: 19A	cockle shells with paint
B.34	T	NW x SE Head NW	7.40					axe A1	stone pounder	shale inlay U.19086
B.35	T	NE x SW Head NE	7.30	ear ring U.19078				axe A1		
B.36	T	NW x SE Head SE	7.10		ear ring			knife 7d	U.19059: 4; U.19082: 41	statue of woman U.19037, Pl. 37
B.37	L	NE x SW Head SW	7.40				2 shell decayed		U.19059: 4; U.19082: 41	
B.38	T	NE x SW Head SW	9.00		beads	U.19076	lapis U.19075 Vol. X, No. 80, large shell de- cayed, small shell decayed	pin with ball head; knife 7a; axe I		

## TABULAR ANALYSIS OF GRAVES

Grave No.	Type	Direction	Metres above sea level	Gold	Silver	Beads	Cylinder Seals	Metal Tools and Weapons, etc.	Copper Vessels	Pottery Vessels (R.C. types)	Stone Vessels (R.C. types)	Variations and Notes
B.39	T	NW x SE Head NW	8.70					pin 2a	bowl 3		calcite vase 92	clay boat
B.40	T		9.00			U.19056	shell, decayed steatite rovel	pin with lapis head; knife				
B.41	L	NE x SW Head NE	7.10			U.19073		pin with ball head	2 bowls		U.19088: 48 white calcite; 7	conch shell as lamp with bird's head U.19089
B.42	T	NW x SE Head NW	8.90				shell, decayed; quartzite U.19071 Vol. X, No. 79	axe 2; pin 2a; reticule; knife 6				axe, pin and reticule and 2 seals hung to- gether from girdle
B.43	T	NW x SE Head NW	8.50			carnelian and lapis		pin 2a	bowl 3; pot 120 U.19123			
B.44	T	NE x SW Head NE	8.50		hair ring	U.19127		pin		53, 108 (2)		
B.45	T	NE x SW Head NE	8.80			2 long carnelian U.19099	shell decayed lapis U.19098	pin 2a	bowl 3			
B.46	T	NE x SW Head SW	8.80					pin U.19100 (head form of woman's head)	bowl 3			
B.47	T	NE x SW Head SW	8.40					axe A1; knife 7a		108, 144 (2)		
B.48	T	NW x SE Head NW	8.90					knife 6; axe A3; reticule	bowl 3	71, 108, 259		
B.49	L	NE x SW Head SW	8.70		finger ring	U.19055		pin paste head 7; pin I: ball head; pin I; adze 2	bowl 3		U.19173: 24	frog and dove amulets part of U.19055
B.50	T		9.00			U.19093	shell U.19104 Vol. X, No. 171	pin 8				
B.51	T		6.30					axe A3; knife 7a; chisel 2a; chisel 4a, U.19128	bowl 3			wheatstone, black pebble

B.52	L	NW x SE Head SE									110	3		
B.53	L	NE x SW Head SW	8.50	ear rings	4 lapis carnelian	shell decayed	adze I	adze I					calcite vase frs. U.19178: 89	
B.54	T	NE x SW Head NE			U.19131	shell decayed	pin, lapis ball head	pin, lapis ball head	bowl					
B.55	T	NW x SE Head NW	8.20			shell decayed	axe A1	axe A1	bowl					
B.56	L	NE x SW Head SW	8.10		ribbed ball lapis	U.19130 Vol. X, No. 52	pin 2a	pin 2a						
B.57	T	NE x SW Head NE	8.10	beads	lapis and carnelian		adze I; knife 7	adze I; knife 7	bowl 3					
B.58	T	NW x SE Head NW	8.40	ear ring	lapis				2 bowls					frs. of ostrich egg originally encrusted, cf. Vol. II, Pj. 156
B.64	T		7.60								108 (2), 126 (2)			
B.65	L	NE x SW Head SW	7.60		1 lapis, 1 carnelian	calcite U.19196 Vol. X, No. 137	knife 7a; 2 needles	pin U.19190; pin I, lapis head knife 7a; 2 needles						
B.66	L	NNW x SSE Head NNW	7.40		lapis and carnelian	shell U.19191, Vol. X, No. 134, shell	pin I haematite ball head	pin I haematite ball head						cockle shells with black paint
B.67	T	N x S Head S	7.30		U.19183		axe A3a	axe A3a	bowl					
B.68	T	NE x SW Head SW	7.20	ear ring	U.19184	shell decayed	axe A1; knife 3; pin	axe A1; knife 3; pin	bowl 3,3				U.19177: 18	
B.69	T	NW x SE Head NW	7.40	beads	lapis carnelian				bowl 3	offering ta- ble with in- cised palm- leaf pattern	60B			
B.70	T	NE x SW Head SW	7.10		lapis		pin 2a; axe S.6	pin 2a; axe S.6	bowl 3	108 (2)			47; U.19187: 61a	frog amulet
B.71	L	NE x SW Head NE	6.80			calcite	knife 7a	knife 7a		108, 110c				
B.72	T		7.10											U.19171: 60b; U.19176: 16a

## TABULAR ANALYSIS OF GRAVES

Grave No.	Type	Direction	Metres above sea level	Gold	Silver	Beads	Cylinder Seals	Metal Tools and Weapons, etc.	Copper Vessels	Pottery Vessels (R.C. types)	Stone Vessels (R.C. types)	Varia and Notes
B.73	T	NW x SE Head NW				U.19182		adze I; pin I with steatite ball head; knife 7b	bowl	108 (4)	76; U.19169: 66; U.19179: 41	
B.74	T	NE x SW Head SW	7.10			U.19181		pin I metal ball head	bowl 3		U.19168: 89; U.19172: 89	cats eye and calcite pendant, see beads U.19181
B.75	T	NNE x SSW Head NNE	7.10			paste and steatite		axe 3a; adze I	bowl 3	5, 108		
B.76	T	NE x SW Head SW	6.80			lapis and carnelian U.19195	shell	pin, curled head	bowl			
B.77	T		6.50	2 ear rings U.19195	heads 4 ear rings & their plate on head U.19195				bowl			
B.78	L	NW x SE Head NW	6.50	2 ear rings beads U.19186		U.19186		pin with ball head U.19186				
B.79	L	NE x SW Head SW	6.40			lapis, carnelian and quartzite U.19194		knife 7a			U.19202: 37b	
B.80	T	NW x SE Head NW	6.40	ear rings				pin I; pin 8	bowl 3		U.20090	lapis amulet of seated cow U.19194
B.81	T		6.30	ear rings	ear rings		U.19205 Vol. X, No. 123	pin I, U.19206	bowl 3, 3			
B.82	T		6.10			lapis			bowl		U.19204: 89; U.19243: 51	
B.83	L	NW x SE Head NW	6.00			U.19200 & shell rings					calcite vase frs.	shell rings at waist
B.84	T	Head NW	5.70	2 ear rings	2 ear rings	U.19203		pin I ball head lapis and gold; axe U.19199			U.19201: 47; U.19221: 16A	



## TABULAR ANALYSIS OF GRAVES

## APPENDIX IVb

## TABULAR ANALYSIS OF THE GRAVES OF THE SARGONID PERIOD

Found in Pit X (PF/G.1 - 163) and in the east corner of the Royal Cemetery area (32/68 - 32/80)

Grave No.	Type	Direction	Metres above sea level	Gold	Silver	Beads	Cylinder Seals	Metal Tools and Weapons, etc.	Copper Vessels	Pottery Vessels	Stone Vessels	Varia and Notes
G.18	T		16.00							26(2), 53, 143 41b		several graves confused
G.19	T		15.00							26(2), 53,		
G.20	T		14.80 circ.							83b(2), 97, 139 198b, 262		
G.21	L		14.20					copper wire bracelet, pin, pin or needle		26, 118		part of leg bone of ox intentionally broken, part of 3 conch shells
G.23	T		15.00					pin 1, rounded head, type 1, fin- ger ring, ear rings		97		type 97 pottery probably not be- longing to grave
G.24			just be- low 15.00							160, 197		
G.25	T	Head NW	14.80							83		behind body, piece of stout wood per- haps coffin side
G.26	T	Head N	14.70							120a		legs rather unusu- ally tightly flexed
G.27	T	Head S	14.50							83, 117, 226		child's grave
G.28	T	Head S	14.50			2 carnelian, 1 paste				268, 270		
G.29	T	Body W Head N	14.50							76, 83, 84, 120b, 133		
G.30	T	NW x SE Head NW	14.80							52b, 76, 117		tablet found nearby but unconnected

G.31	T		14.50			120b, 269	bitumen boat; v. Pl. 7,d
G.32	T		14.50		2 ear rings	76(2), 100b	
G.33	T		14.60			76, 100b	
G.34	T		14.00			4b, 34, 81, 83b, 115, 116, 202, 258	
G.35	T		15.00			76, 83, 216, 261	
G.37	T	Head N	14.40		razor, axe (broken) type S.8(?), kohlstick ?	57a	
G.39	T		14.20		pin with curled over end (type 4)	11(3), 26, 53, 76(2), 83c(2), 110c	
G.40	T	NE x SW Head SW	14.00			40, 145	coffin painted with bitumen inside and out pit lined with mudbrick; bricks 0.25 x 0.18 x 0.15 m; Pl. 7, c remains of bitumen boat.
G.41	L	NE x SW Head NE	13.20		2 bracelets		
G.42		NNE x SSW Head SSW	13.40			strainer, 33b, 117 (and variant), 261	
G.43	T		13.50			75, 76, 53, 83c, 257	
G.44	T		13.80			11, 26, 34, 75, 83b, 83d, 132a (2)	pots may belong to 2 contemporary graves at same level
G.45	T	NNE x SSW Head SSW	13.50		knife	137, 145?, 168	
G.46	L	NNE x SSW Head NNE	13.00			140	close by but not be- longing to grave but same level
G.47		Head NNE	13.20			26, 75, 76, 83b	
G.48	T	Head NNW	13.40		axe S type (frag- mentary)	76, 112, 120a	
G.49	T		13.70			5b(2), 26, 73, 132a, 225	no body; upper and lower grindstone of diorite, lower set in bitumen
G.50			13.40				

## TABULAR ANALYSIS OF GRAVES

Grave No.	Type	Direction	Metres above sea level	Gold	Silver	Beads	Cylinder Seals	Metal Tools and Weapons, etc.	Copper Vessels	Pottery Vessels	Stone Vessels	Varia and Notes
G.51	T	Head W	13.60					2 finger rings, 2 bracelets, pin type 3		11, 83b, 119a, 187		
G.52	T	Head NNE	13.50					pin type 1, knife		76, 119b		
G.53	T	Head SW	13.30							76(7)		
G.54	T	Head SW	13.70 circ.							76, 120(2), [75, 76(2), 83, 120a, 138, 225, 256]		in brackets are pots found N. of grave, same level not belonging but contemporary; 225 had haematite wash
G.55	T	NW x SE Head SE	13.00					ring, pin type 3, 2 finger rings.		26, 225		first ring near foot
G.56	T	NE x SW Head SW	13.40					bracelet		75, 76, 120a, (2)		
G.57	T	Head NNW	13.50	2 lunate ear rings U.18881, beads		U.18880 (bleached carnelian)		pin type 3, 2 bracelets	bowl	5 (apparently)		
G.58	T	NNE x SSW Head SSW	13.20			3 carnelian		pin type 3, axe.		11(2), 76, 135(3)		close to grave, contemporary but not belonging; copper vase
G.59	WC	NNE x SSW	12.80		ear ring	carnelian & jasper various shapes			bowl			
G.60	T	NE x SW Head SW	13.00	narrow ribbon, 2 ear rings, beads, finger ring U.18891				pin type 1, finger ring.		(2 pots no type)		
G.61	T		13.00	beads		gold		pin straight, 2 bracelets, 2 finger rings				
G.62	T	NNE x SSW Head SSW	12.70			crystal, carnelian, marbled paste		finger ring, pin.				



G.63	T	Head SW	12.80		dark steatite U.18896, Vol. X, No. 297	finger ring, pin type 3	120a	cylinder attached to pin, U.18896
G.64	T	Head SSW	13.00	lunate ear ring U.18888.	carnelian and agate			
G.65a	T	NNW x SSE Head NNW	12.70	beads U.18887	U.18887	4 bracelets	26, 225	
G.65b	T		12.90			ear rings, bracelets, finger ring, pin type 3	51, 53, 267	these 3 pots near and perhaps belonging to grave
G.66	T	Head SSW	12.90			pin type 1, 2 bracelets	26, 131, 198a	near but perhaps not belonging, 2 clay pots 76
G.66b			13.00		jasper, carnelian.	pin	76(2), 198a	group of pots but no grave
G.67	T		13.00			finger ring	76, 133(4)	
G.68	BC	NW x SE Head NW	12.40		1 carnelian	pin type 3	39(2), 53	
G.69	T	NW x SE Head NW	13.00			axe, S type, (fragmentary)	44b, 76(2)	
G.70	T	NW x SE Head NW	12.70				76, 83b, 219, [53, 76(2), 83a, 222 ]	in brackets, pots perhaps belonging; contemporary
G.71			12.50				34, 76(2), 112, 241	group of pots only, no grave
G.72			12.60				83b(2), 110c	group of pots only, inside last one were dates
G.73	T		12.50	1 bead	lapis, carnelian, gold	pin type 3		
G.74	T	NE x SW Head SW	12.50	ring	lapis, carnelian, copper	pin type 8	26, 48, 75, 83b(2), 97, 120b	
G.75			12.50				126, 235	
G.76	T	NW x SE Head NW	12.00		carnelian and stone	2 bracelets, axe S type	26, 44b, 58, 76, 83b, 117, 192, 200, 219, 224	pots only, no grave
G.77	T	NE x SW Head SW	12.20		carnelian, crystal, lapis			

## TABULAR ANALYSIS OF GRAVES

Grave No.	Type	Direction	Metres above sea level	Gold	Silver	Beads	Cylinder Seals	Metal Tools and Weapons, etc.	Copper Vessels	Pottery Vessels	Stone Vessels	Varia and Notes
G.78	T		12.80		finger ring	lapis, carnelian, limestone		finger ring, pin type 3	bowl			
G.79	T	NE x SW Head SW	12.20					toe ring, 2 bracelets	vase	76, 115, 221, [5b, 53(2), 75(2), 83b(2), 114]		in brackets pots close to G.80 probably not belonging but contemporary
G.80	T	NE x SW Head SW	12.50					finger ring, pin				group of pots only, 219 had substance requiring analysis in it; copper bowl was close by others
G.81			12.80						bowl	39, 75, 219		
G.82	T	NE x SW Head NE	12.00							5b(7), 83b, 97, 117, 120b.		
G.83	BC	E x W Head W	11.50					2 chisels, 1 saw	bowl	76(2), 124.		fragment of wooden handle
G.84	T	NW x SE Head NW	12.00		ear rings	carnelian & different stone ones U.18901		U.18903, pin or awl				bitumen boat
G.85	T	NE x SW Head NE	11.80				U.18898 Vol. X, No. 160	reticule		53		
G.86			13.00					axe		38a, 44b(3), 133, 198a, 197		remains of bitumen boat and with it the group of pots
G.87	T	NNE x SSW Head SSW	12.00	ear ring (see copy per) U.18971				axe type S.16, U.18904. 2 razors, a copper ear ring, axe type S.13		53		
G.88	T	NW x SE Head NW	11.80					pin type 1a	bowl	44b, 76		
G.89	T	NE x SW Head SW	11.60							53, 187, 219(2)		

G.90	T	NNW x SSE Head NNW	12.00		gold plated, lapis and carnelian U.18900	steatite U.18899 Vol. X, No. 281	finger ring	bowl	39, 83b, 120b (4), 219, 224, 225(2)		
G.91	T	NE x SW Head SW	12.30	ear ring		black stea- tite U.18925 Vol. X, No. 176	pin 8, ear ring, knife type 7a, U.18940		5b(3), 260		
G.92	T	NW x SE Head NW	12.00					bowl 2, axe blade S.13 U.18941	53, 83(2), 120a(3), 224	at foot of grave a bitumen boat	
G.93	T		12.60	2 lunate ear rings, ring, and beads U.18944	U.18944					0.40 above grave a bitumen boat	
G.94	T	NE x SW Head SW	11.00	spiral rib- bon U.18930, together w. gold ones beads, finger ring	U.18930, gold, silver, lapis, agate	steatite, U.18924 Vol. X, No. 183	reticule, finger ring, pin	bowl, bowl	48, 198, 263	pair of earrings, one gold one silver lunate interlaced	
G.95	T		11.30	bracelet U.18942	long string mixed		pin type 1, with lapis ball head	bowl		remains of limestone bowl.	
G.96	T	NW x SE Head NW	11.00				pin, type 2a	bowl			
G.97	T	NW x SE Head SE	11.30	p. lunate ear rings			pin type 8			36: U.18955	
G.98	T	NE x SW Head SW	11.00			steatite U.18916, Vol. X, No. 307	pin type 2a		60		an infant by woman's side
G.99	T	NW x SE Head NW	11.80	ball heads	agate, car- nelian, lapis and silver		2 bracelets, tumbler				
G.99b						steatite U.18922 Vol. X, No. 92,	pin, type 2a				shell cylinder lay above to W. of 99b

## TABULAR ANALYSIS OF GRAVES

Grave No.	Type	Direction	Metres above sea level	Gold	Silver	Beads	Cylinder seals	Metal Tools and Weapons, etc.	Copper Vessels	Pottery Vessels	Stone Vessels	Varia and Notes	
G.99b cont'd							steatite U.18921 Vol. X, No. 179, shell U.18923 Vol. X, No. 135 black steatite U.18926 Vol. X, No. 131						
G.100	T	NE x SW Head SW	11.00		ear rings inter- twined with gold finger ring	lapis crys- tai, silver, blue glaze.	dagger type 7b, U.18935, axe type S.6, U.18934, reticule U.18936	bowl, bowl		5a, 46(2)			
G.101	T	NW x SE Head NW	11.00	ribbon, ear rings			pin type 8, reti- cule, pin, ladle or spoon					whole group under U.18943	
G.102	T		11.80	2 ear rings		carnelian, crystal U.18931	finger ring						
G.103	T		10.10				square steatite stamp U.18928, Vol. X, No. 633	pin type 2a		219(2)			
G.104	T	NE x SW Head SW	10.50				greenstone with cop- per caps U.18919 Vol. X, No. 244	dagger	bowl	219, 224			
G.105	T	NE x SE	10.80				steatite U.18927 Vol. X, No. 288	pin type 8, 2 bracelets					
G.106	T	NW x SE Head NW	11.80			U.18932						54: U.18945	



## TABULAR ANALYSIS OF GRAVES

Grave No.	Type	Direction	Metres above sea level	Gold	Silver	Beads	Cylinder Seals	Metal Tools and Weapons, etc.	Copper Vessels	Pottery Vessels	Stone Vessels	Varia and Notes
G.119	T	NW x SE Head NW	11.00	ear ring lunate interlaced U.18960 beads	ear ring lunate interlaced beads	gold, silver, lapis and paste U.18960		pin type 8	bowl	44, 76(4), 187		
G.120	T	NW x SE	11.00	2 lunate ear rings interlaced U.18950 beads				axe type S.16	bowl			
G.121	T		10.00			U.18958		pin type 2a, axe type A3a		5a, 108(3)	78: U.18959; 80: U.18957	cockle shells with black paint ruined, and body gone
G.122	T		11.20			U.18954		2 bracelets		201		
G.123	T		11.20			3 crystal beads, large	U.18948, Vol. X, No. 507, U.18949, Vol. X, No. 298	pin, finger rings, bracelet	bowl	5a, 76(4), 83, 120		
G.125	T		11.50	beads: ear ring U.18965		bleached carnelian etc. U.18965		copper ear rings, small lunate; pin				
G.126	T	NE x SW Head SW			beads	paste and lapis		razors, U.19007				
G.128	T	NW x SE, Head NW	10.00				U.19008, Vol. X, No. 304	bracelet, 2 reticules, knife type 7a		46 (haematite wash), 120b		
G.129	T	NE x SW Head SW	10.20		lunate ear rings beads	lapis and carnelian		pin type 2a	bowl 4	46, 83b, 110		
G.130	T	NE x SW Head NE	11.00		lunate ear rings				bowl 4, bowl 3, jar 69, U.19133	75, 76, 108, 160, 202(3)		several graves confused
G.131	T	NW x SE Head NW	10.60			U.18997		pin type 2a, ear ring, finger ring				
G.133	T	NE x SW Head SW	10.40		lunate ear ring	bleached carnelian etc. U.19021	U.19004, Vol. X, No. 143	pin type 2a, knife type 7a			5: U.19015	

G.134	T	NE x SW Head SW	11.30	bead	carnelian and lapis U.19026	U.18984	pin type 8		51a (haematite wash), 76(3), 197	
G.135	T	NE x SW Head SW	10.70		lunate ear rings	U.18978 U.18979 Vol. X, Nos. 292 & 166	reticule, 2 knives type 7a, 2 axes type S.6, pin type 2a			
G.136	T	NW x SE Head NW	10.60		lunate ear rings	U.18982 Vol. X, No. 165	bracelet, pin type 8	bowl 3 U.19018	83b(2), 191, 198 48, 53, 76, 198b(2)	
G.137	L	NW x SE Head NW	10.80	1 bead	small lapis & carnelian	U.18973, U.18974, Vol. X, Nos. 237, 295	pin type 2a	bowl 4	76(2)	5 (calcite)
G.139	T	NE x SW Head SW	10.60	fillet U.19018 ear rings	carnelian & chalcedony U.19018	U.18975 Vol. X, No. 228	knife type 7a, axe type S.12	bowl 4		
G.140	T	E x W Head W	10.40		lunate ear rings	U.18981 Vol. X, No. 187	axe type S.5, reticule			
G.141	T	NW x SE Head NW	10.60		1 carnelian	U.18976 Vol. X, No. 76	pin type 8, finger ring, lunate ear ring			
G.142	T	NE x SW	10.50				pin type 2a			
G.143	T		10.60				razor, pin type 2a	bowl 3	76	
G.144	T	NW x SE Head NW	10.40	beads	lapis and crystal U.19047	U.19005 Vol. X, No. 156	pin type 8, axe type S.14(2)			
G.145	T	NE x SW Head NE	10.40		lunate ear rings coiled hoop ear rings	U.19005 Vol. X, No. 156	pin type 8, axe type S.14(2)			
G.146	T	NE x SW	10.00	fillet and frontlet U.19022 A-B, beads	U.19022 bracelets	shell (decayed)			41a, 44c, 51a (haematite wash), 76(3), 97, 200	
G.148	T		10.80		U.18995	U.18994 Vol. X, No. 200	pin type 8, fin- ger ring, brace- lets, axe type S?	bowl 3	7d, 44b(2), 53, 83(3), 108, 119	copper butt end of staff(?)





G.163	T		9.60				pin type 2a, pin, reticule	cauldron and bowl U.19134 Pl. 58	197(2)	matting with traces of bitumen matting with traces of bitumen bitumen boat
GRAVES CLOSE TO THE S.W. WALL OF DUNGI'S MAUSOLEUM										
32/68	T	NE x SW							53, 75, 81, 20a variant 4b, 75	
32/69	T	NW x SE							4b, 13, 37, 100b, 120b, 186	
32/70	T								11, 53, 83 c variant, 126, 225 (haematite wash)	
32/71	MC	NE x SW Head NE				silver balls and steatite date-shaped	axe type S.13			
32/72	T	NE x SW Head NW					axe type S.13		26, 75, 223 (haematite wash), 224 (haematite wash)	mat burial
32/73	T								26, 120a variant, 120b	mat burial
32/74	MC	NW x SE Head NW				agate date-shaped, copper balls, shell cylinder	copper bracelets, axe type S.13	bowl 116 U.17875	97, 127, 224 (haematite wash)	
32/77	T								26	child's body in matting
32/78	MC	NE x SW Head SW					copper amulet and bracelet		11, 44b, 83c (haematite wash), 97 75, 83c, 110c, 224	group of pots only
32/79										
32/80	T	NW x SE Head NW					copper pin, bracelets and finger rings		110c, 198b	mat burial

## APPENDIX V a

## THE OCCURRENCES OF THE AL 'UBAID POTTERY TYPES

Nearly all of these types occurred in the PFG graves, of which the numeral letters are here recorded; where no grave-letter and no pit-number is given it means that the vessel was found loose in the soil with no satisfactory evidence for close dating.

Type Number	Provenance	al 'Ubaid Period
1	O	II
2	O/U/Y/AA/BB/CC	II
3a	J/L/M/N/O/V/Z/AA/FF/GG/JJ/KK/PP/QQ/RR/SS/UU	III - II
3b	J/K/M/O/V	III - II
4	N/Q/Z/AA/BB/MM/NN/OO/QQ/RR/VV	II
5	R	II
6	LL	II
7	N/CC/JJ	III - II
8	T/AA/CC/TT	II
9a	L	III
9b	J/K	III
10a	Q/W/Z/EE/GG/MM	II
10b	UU	II
11		
12	E/F	III
13	A/B/C	III
14	Pit F, sq. E7, level 6.00m.	
15		
16	R	II
17	AA <i>bis</i>	II
18		
19	BB	II
20	FF	II
21	P/MM/WW	II
22	SS	II
23	O/P/Q/R/T/U/V/X/CC/HH/KK/MM/RR/SS/TT	II
24	K/L/M/N	III
25	K/M/N/P/R/S/T/U/V/W/X/Y/Z/AA/GG/JJ	III - II
26	U/V/Z	II
27	LL/VV	II
28	EE	II
29	Z/VV	II
30	AA/CC/OO/UU/VV	II
31	GG/JJ/KK/OO/RR/WW	II
32	P/Q/U/CC/MM	II
33	G/O/PP	III - II
34	N/CC/FF/MM	III - II
35		
36		
37		
38	GG/JJ/WW	II
39	O	II
40		
41	TT/XX	II
42	KK	II
43	Q/V/JJ/SS	II

## OCCURRENCES OF THE AL 'UBAID POTTERY TYPES

147

Type Number	Provenance	al 'Ubaid Period
44	GG	II
45	UU	II
46		
47	O/Z/AA/BB/DD/JJ/OO/TT/XX	II
48	R	II
49	Z	II
50	QQ	II
51	Pit K	
52	CC	II
53		
54		
55	Q/R	II

## APPENDIX Vb

## NOTES ON THE MATERIAL, OCCURRENCE AND RELATIVE DATING OF THE POTTERY TYPES OF THE JAMDAT NASR PERIOD

## A. Types found in the graves

Type No. JN	No. of graves in which it occurs	Relative date of graves		No. of other types associated	Relative date of associated types		Notes
		Early	Early or Middle		Early	Early or Middle	
14	1	1	-	1	1	-	greenish drab ware
26	1	1	-	4	4	-	drab clay
28	1	1	-	2	2	-	light drab clay
30	2	2	-	3	1	2	deep red clay with cream-coloured slip, and light red clay with haematite wash burnished, U.19979
36	1	1	-	4	1	3	pink clay with 3-colour decoration
44	2	2	-	2	2	-	deep red clay with cream-coloured slip; miniature example in light red clay
46	3	3	-	10	4	6	red or light creamy clay
50	1	1	-	5	1	4	reddish drab clay
53	3	3	-	3	-	3	red or light drab clay
58	1	1	-	4	4	-	drab clay
62	6	2	4	13	3	10	one three-colour example U.20025, one in bright cream-coloured clay, one red clay with buff surface, one miniature example
63	2	2	-	5	3	2	reddish drab clay
79	1	1	-	3	-	3	also in Pit F, Building Stratum H; light red clay
84	1	1	-	2	1	1	light greenish drab clay
88	1	1	-	2	2	-	light reddish drab clay
89	2	1	1	3	1	2	red or drab clay
91	1	1	-	7	4	3	also in Pit F, level 10.80 m.; light drab clay
92	1	1	-	-	-	-	pinkish drab clay, found in an inhumation grave low down in Pit Y
95	1	1	-	2	2	-	light drab clay
98	4	4	-	8	5	3	red clay
101	2	2	-	3	1	2	one of drab clay, one of red clay, with creamy surface
106	1	1	-	-	-	-	
110	2	2	-	7	5	2	not recorded

Type No. JN	No. of graves in which it occurs	Relative date of graves		No. of other types associated	Relative date of associated types		Notes
		Early	Early or Middle		Early	Early or Middle	
113	1	1	-	1	-	1	also Pit F level 8.50-8.00 m., and in lower soil of Dungi's N. W. Mausoleum, below the tomb foundations
119	1	1	-	7	4	3	light drab clay
124	7	7	-	9	1	8	drab, reddish drab or light red clay
125	1	-	-	7	4	3	pinkish drab clay
126	2	2	-	5	1	4	also Pit F, Building Stratum E (?); reserved slip ware, cable pattern at base of neck; also in drab or reddish drab clay
129	11	11	-	15	2	13	clay red, reddish drab, drab, greenish drab and very light cream-coloured
135	2	2	-	11	8	3	light drab clay
136	6	6	-	11	1	10	right red, reddish drab or drab clay
144	5	5	-	8	2	6	red, drab or greenish drab clay

## TYPES COMMON TO THE WHOLE PERIOD

Type No. JN	No. of graves in which it occurs	Relative date of graves			No. of other types associated	Relative date of associated types			Notes
		Early	Middle	Late		Early	Middle or Common	Late	
6	6	2	2	2	12	4	7	1	red clay
9	1	-	1	-	-	-	-	-	drab clay
20	73	11	24	38	62	9	20	33	red, light red or drab clay
23	33	7	9	17	32	3	13	16	red, light red or drab clay
31	2	1	-	1	6	1	4	1	yellowish drab clay, and red painted clay
35	1	-	1	-	-	-	-	-	whitish drab clay (miniature, U.15107).
37	5	2	2	1	9	4	4	1	reddish clay with buff surface, buff clay with red haematite wash, red clay or drab
38	7	3	3	1	12	3	8	1	grey, drab, pinkish drab or red clay, one with haematite wash burnished
48	5	3	-	2	11	5	3	3	drab or light buff clay, one with plum-coloured matt wash, one with three-colour decoration
51	1	-	1	-	-	-	-	-	drab clay (U.14460).
60	10	4	5	1	20	4	14	2	usually of red clay or pinkish drab, one of red clay with buff surface
67	3	1	-	2	4	1	2	1	also Pit F, Building Stratum H; level 10.00-9.00 m., reddish drab or smooth greenish drab ware; one of light drab with cream-coloured slip, reserved slip ware
73	9	4	2	3	16	2	13	1	red or greenish drab clay, one example with red haematite wash
75	1	-	1	-	-	-	-	-	light drab clay
104	21	6	10	5	30	3	18	9	red, reddish drab, brownish drab, yellowish drab, drab and pink clay, red body with cream-coloured engobage, one example with haematite wash, one of reserved slip ware
105	11	5	3	3	13	3	9	1	red, pinkish drab or drab ware, one of red body clay with buff engobage
111	34	11	7	16	43	9	15	19	coarse red or brownish buff ware
116	17	2	9	6	19	4	12	3	red, light red, reddish drab, drab and buff clay
117	7	2	3	2	16	2	12	2	red, reddish drab, red with drab engobage, or drab clay
121	6	2	-	4	9	1	2	6	also Pit F, at Kiln level; red, yellowish or drab clay, once with painted red decoration on shoulder
123	11	3	5	3	13	1	9	4	also Pit F, Building Stratum F, level 10.00-9.00 m.; always of drab-coloured clay, once with reserved slip decoration in cream
130	1	-	1(?)	-	-	-	-	-	also Pit F, Building Stratum H; red clay; and in lower soil of Dungi's N.W. Mausoleum, below the tomb foundations
137	8	3	2	3	17	3	12	2	red or reddish drab clay, once red with creamy engobage
138	10	3	6	1	11	2	9	-	red, reddish drab, drab or buff clay, once of red clay with drab engobage
139	11	1	-	10	18	1	6	11	red, pinkish, yellowish or drab ware, usually coarse and rough; once of fine red ware, once with reserved slip decoration
140	39	3	25	11	21	5	11	5	all colours; often roughly made of coarse clay

## LATE TYPES

Type No. JN.	No. of graves in which it occurs	Relative date of graves		No. of other types associated	Relative date of associated types		Notes
		Middle	Late		Middle or Common	Late	
1	3	-	3	9	3	6	roughly made of coarse pinkish drab clay large coarse bowls of various colours of clay, always rather roughly made; also in lower soil of Dungi's N.W. Mausoleum, below the tomb foundations coarse reddish drab clay; also in Pit W, level 6.00 m., and in lower soil in Dungi's N.W. Mausoleum, below the tomb foundations coarse yellowish clay made in all sorts of clay, generally coarse, the potting rough red clay, apparently an imitation of a stone type also Pit F, Building Stratum H, down to 10.00 m.; red or reddish brown clay red clay also Pit F, level 7.00-6.50 m.; red clay also Pit F, Building Stratum G; examples in rough yellowish ware, red and drab-red body clay with yellowish slip, drab clay with plum-red overall paint drab clay once in yellow clay, plain; once of red clay with creamy slip; once with 3-colour decoration once in slate-coloured clay, U.20075; others of finely burnished black smother-kiln ware U.19298, U.19551 red or cream-coloured ware, one of greenish drab, smooth and well potted light red clay generally roughly made red, drab, pink or yellowish clay; twice of red clay with creamy slip, once in reserved slip ware red clay, smoothly worked and well potted red or yellow clay; one very hard-fired, clay purplish red in section with creamy white engobage red or pink ware red clay; one miniature example drab clay also Pit F, level 11.00-7.50 m.; light yellow or pinkish drab clay; one of pale reddish brown ware, lightly burnished also Pit F, Building Stratum G; most examples rough in yellow drab, pink or red clay; one finely polished; one miniature in blackish grey smother-kiln ware deep red burnished ware red or yellowish clay, generally rather rough, but once lightly burnished; pink clay with creamy engobage; one painted red all over and burnished
4	11	-	11	14	4	10	
8	1	-	1	7	5	2	
10	1	-	1	-	-	-	
16	19	-	19	31	5	26	
17	2	-	2	7	1	6	
19	2	-	2	6	4	2	
21	3	-	3	5	5	-	
24	1	-	1	2	-	2	
25	6	-	6	17	3	14	
27	1	-	1	1	-	1	
32	4	-	4	7	3	4	
33	4	-	4	5	3	2	
39	4	-	4	7	2	5	
43	2	-	2	3	2	1	
45	11	-	11	17	3	14	
47	1	-	1	1	-	1	
54	4	-	4	12	4	8	
55	2	-	2	6	1	5	
56	4	-	4	2	1	1	
57	1	-	1	3	1	2	
59	3	-	3	8	2	6	
61	9	-	9	16	4	12	
64	1	-	1	3	2	1	
65	9	-	9	15	3	12	

Type No. JN.	No. of graves in which it occurs	Relative date of graves		No. of other types associated	Relative date of associated types		Notes
		Middle	Late		Middle or Common	Late	
66	1	-	1	1	-	1	greenish grey clay very smoothly finished; copy of stone type
71	3	-	3	8	2	6	rough red or pinkish ware
72	2	-	2	8	2	6	also Pit F, Building Stratum E; red clay with light creamy slip
74	3	-	3	6	5	1	greenish drab clay
77	6	-	6	13	3	10	also Pit F, Building Stratum F, G; of light coloured clay, red, yellow, greenish drab; that from Pit F was pinkish grey and of almost egg-shell thinness
81	-	-	1	1	-	1	light drab clay
82	1	-	1	2	-	2	light red clay; also from Pit Y, level 5.00 m. yellowish drab clay
86	3	-	3	3	-	3	light drab or red clay; and in Pit F, 11.00-10.00 m.
87	4	-	4	2	2	-	also Pit F, Building Stratum E; red or reddish drab clay, sometimes with drab engobage; roughly made
90	3	-	3	6	1	5	rough yellowish ware
93	1	-	1	4	1	3	yellow clay
96	4	1	3	5	2	3	red clay with haematite wash
97	1	-	1	2	-	2	bright haematite wash over red body clay
100	3	-	3	8	2	6	red, or pinkish drab ware flared to red; one miniature example
103	3	-	3	6	2	4	drab or light reddish drab clay
112	14	-	14	18	3	15	red, drab or yellowish clay, usually roughly made; once of red clay with light creamy engobage, once of reserved slip ware
114	3	-	3	11	4	7	coarse yellowish ware
120	1	-	1	2	-	2	also Pit F, Building Stratum F; one of greenish ware with rough decoration in red paint on shoulder
122	23	-	23	32	6	26	red or light red, pink, yellow or drab clay, often rough; once with pinkish cream slip over dark red body clay
133	9	-	9	13	2	11	also Pit F, Building Stratum F; once of finely levigated reddish drab clay, once of red, usually of light drab or cream-coloured ware
134	1	-	1	-	-	-	red clay
141	6	-	6	10	-	10	also in Pit F, Building Stratum F; red, drab or rough yellow clay, twice of greenish drab
146	5	-	5	12	3	9	also Pit F, Building Stratum G, level 11.00-9.00 m.; red, yellow, drab and fine pinkish clay
148	1	-	1	1	-	1	dark greenish drab clay
152	12	-	12	17	5	12	red or (more often) rough yellowish clay
153	6	-	6	14	3	11	red, drab or coarse yellowish ware; one example has spots of red paint
156	6	-	6	8	1	7	usually of drab, examples of red and rough pinkish ware
158	6	-	6	7	2	5	rough reddish or drab ware, once of pink clay with creamy slip, once of whitish drab clay



## B. Types found elsewhere than in graves

Type JN.	
2	Pit F, Building Stratum F, kiln stratum, down to level 6.50 m. Always coarse and rough, often hand-made; the rim is knife-trimmed. Also in lower soil of Dungi's N.W. Mausoleum, below the tomb foundations.
3	Pit F, level c. 10.00 - 9.50 m., drab clay. Pit W, drab clay
5	Pit F, level 9.40 m., drab clay
7	Pit W, at grave level, drab clay
11	Pit F, level 10.80 m., plain drab clay
12	Pit F, level c. 7.50 m., light greenish cream clay; level 7.30 m. whitish drab clay; level 7.00 m. greenish drab clay; level 6.70 m. greenish drab clay
13	Pit F, Building Stratum G, drab clay
15	Pit F, level c. 8.00 - 7.50 m., light red clay
18	Pit W.
22	Pit F, Building Stratum E, coarse light drab clay
29	Pit F, level 8.00 m., light red to drab clay
34	Between 6.00 and 6.50 m., down in rubbish stratum on E. side of Royal Cemetery area; black burnished ware, smother-kiln fired
40	Pit X, grave level, pinkish drab clay
41	Pit F, Building Stratum E, pinkish drab clay
42	Pit Y, level 3.00 m., light drab clay
49	Pit Y, level 3.00 m., light drab clay
52	Pit F, Building Stratum H, pink clay with greenish drab surface and a pattern in red paint, U.14418
68	Pit F, Building Stratum G, level 7.50 m., light red clay
69	Pit F, level 10.00 - 9.00 m. to level 7.50 m., light red clay
70	Pit F, level 7.00 - 6.50 m., reddish drab clay
76	Pit F, level 10.00 m. red clay
78	Pit F, in drain (v. Building Stratum B), Building Stratum H, painted all over with powdery red paint
80	Pit F, Building Stratum H, Sq. D6, pinkish drab clay
83	Pit W, at grave level, light reddish drab clay
85	Pit W, at grave level, drab clay
94	Pit W, level of JN graves, drab clay
99	Pit W, level of JN graves
102	Pit F, Building Stratum H, drab clay
107	Pit F, level 11.00 - 9.00 m., light drab clay
108	Pit F, level 8.00 - 7.50 m., Sq. C7, coarse greenish grey surface, black-grey in section
109	Pit W, level of JN graves. Also below the tomb chamber in lower soil of Dungi's N.W. Mausoleum
115	Pit X, at grave level, red clay
118	Pit F, level 7.00 m., very light drab clay, miniature
127	Pit F, Building Stratum H, Sq. D6, light reddish clay with drab surface
128	Pit F, Building Stratum G, drab clay
131	Pit F, level c. 8.00 m., (two examples) one light greenish drab clay, the other drab clay
132	Pit F, Building Stratum H, very light drab clay

Type  
JN.

- 142 Pit X, at grave level, light reddish clay, creamy surface  
 143 Pit W, at grave level, light red clay  
 145 Pit F, level c. 10.00 - 9.50 m., light red clay  
 147 Pit W, at grave level, light red clay  
 149 Pit F, level 10.00 - 9.00 m., Sq. D6, drab clay  
 150 Pit F, level 9.00 - 8.50 m., light red clay, creamy surface  
 151 Pit X, at grave level, light red clay  
 154 Pit F, level c. 11.00 - 10.00 m., drab clay  
 155 Pit W, at grave level, light drab clay  
 157 Pit W, at grave level, drab clay  
 159 Pits W and X, inverted over graves; reddish brown or drab clay  
 160 Pit F, level c. 11.00 - 10.00 m., greenish drab clay  
 161 Pit F, level 8.90 m., Sq. D6, light reddish clay  
 162 Pit F, Building Stratum B, blackish grey clay (probably later than JN; Royal Cemetery period?)  
 163 Pit F, at deep levels, coarse drab clay, miniature (several)  
 164 Pit X, at grave level, light red clay  
 165 Pit F, Building Stratum H, pinkish drab clay  
 166 Pit X, at grave level, red clay  
 167 Pit F, Building Stratum C, coarse drab clay

APPENDIX Vc

NOTES ON THE MATERIAL, OCCURRENCE AND RELATIVE DATING OF THE STONE VASE TYPES OF THE JAMDAT NASR PERIOD

V. Plates 65-67

No.	Materials, etc.	Provenance	Date
1	Diorite, basic diorite, limestone (once)	JNG/182, 220, 229, 243, 258, 285	JN Late
2	Limestone: one example only, decorated (Pl. 34)	JNG/136	JN Late
3	Alabaster	JNG/223, 348	JN Middle
4	Diorite, basic diorite, limestone, calcite	JNG/10, 42, 51, 89, 92, 102, 133, 135, 154, 174, 177, 179, 180, 193, 205, 213, 214, 222, 243, 255, 267, 278, 289, 292, 295, 296, 305, 306, 318, 324, 336, 347, also from Mereijib	JN All periods
5	Diorite, basic diorite, limestone	JNG/16, 38, 49, 75, 104, 287, 337	JN All periods
6	Diorite, limestone	JNG/42, 55, 220	JN Late
7	Diorite, basic diorite	JNG/146, 312	JN All periods
8	Diorite, basic diorite, green stone, limestone	JNG/20, 59, 73, 95, 156, 157, 162, 173, 186a, 187b, 191, 193, 195, 198, 201, 205, 209, 217, 228, 230, 232, 235, 236, 238, 242, 258, 268, 280, 284, 295, 296, 310, 329, 337, also from Abu Kumbareh	JN All periods
9	Diorite, basic diorite, limestone, calcite	JNG/45, 119, 135, 137, 150, 188, 193, 197, 199, 221, 234, 250, 265, 287, 295, 296, 301, 302, 338, 350, 351, also from Bussokheir	JN, rarely early, mostly middle and late
10	Diorite, basic diorite, limestone, calcite	JNG/61, 72A, 86, 90, 101, 141, 175, 191, 197, 199, 205, 221, 240, 249, 272, 283, 305, 315, 349, 355.	JN All periods
11	Diorite, basic diorite, limestone	JNG/3, 55, 269, 337	JN All periods
12	Diorite, basic diorite, limestone, calcite	JNG/16, 22, 24, 46, 53, 91, 93, 154, 161, 173, 186A, 186B, 187A, 187B, 189, 192, 204, 210, 225, 232, 241, 246, 251, 260, 264, 281, 289, 290, 328, 331, 356, 365 and Bussokheir	JN All periods
13	Diorite, basic diorite, igneous rock, limestone, alabaster	JNG/34, 45, 80, 84, 90, 128, 198, 201, 205, 230, 250, 264, 356 and Bussokheir	JN Middle and late
14	Diorite, basic diorite, limestone, alabaster	JNG/35A, 242, 256, 264, 284, 294, 321, 329, 338, 356	JN All periods
15	Diorite, basic diorite, limestone	JNG/124, 152, 174, 183, 187B, 198, 221, 277, 280, 282, 288, 296, 300, 338, Pit F, Building Stratum E	JN All periods
16	Diorite, basic diorite, limestone (white and pink), calcite	JNG/25, 82, 109, 122, 129, 137, 145, 148, 272, 287, 340, 342, 349, 363	JN All periods

No.	Materials, etc.	Provenance	Date
17	Diorite, basic diorite, schist, limestone (pink and white), alabaster, steatite	JNG/5, 43, 94, 254, 287, 303, 342, 343, 354, 356, and Bussokheir	JN All periods
18	Limestone (exclusively)	JNG/5, 7, 34, 42, 44, 52B, 55, 87, 112, 236, 259, 286, 335	JN Late
19	Diorite, basic diorite, limestone, marble, steatite	JNG/62, 84, 97, 130, 142, 176, 200, 208, 238, 271, 291, 298, 331, 370 and from Bussokheir and Pit F, Building Stratum E	JN, once early, generally middle and late
20	Diorite, basic diorite, limestone	JNG/36, 46, 47, 58, 59, 80, 105, 129, 150, 160, 198, 251, 257, 264, 284, 288, 298, 309, 311, 315, 316, 321, 325, 330, 335	JN, rarely early, generally middle and late
21	Diorite, basic diorite, limestone, steatite	JNG/18, 58, 72B, 94, 154, 160, 367, also Bussokheir	JN Late
22	Basic diorite, schist, limestone	JNG/14, 58, 84, 154, 191, 195, 197, 253, 279A, 298, 308, 313, 331, Bussokheir, Pit F, Building Stratum E	JN All periods
23	Diorite, basic diorite, limestone, steatite	JNG/45, 59, 74, 160, 161, 187B, 188, 237, 309, 311, Bussokheir	JN, Middle and late
24	Diorite, basic diorite, limestone, calcite	JNG/2, 18, 104, 152, 153, 154, 156, 157, 159, 160, 177, 182, 188, 189, 190, 191, 193, 196, 203, 204, 206, 211, 218, 221, 222, 225, 226, 227, 228, 229, 230, 231, 234, 238, 241, 243, 244, 247, 248, 251, 254, 255, 258, 259, 264, 265, 266, 268, Merejib	JN, All periods but most common in middle
25	Diorite, basic diorite, limestone	JNG/1, 2, 34, 113, 155, 236, 270, 271, 274, 275, 279, 279A, 281, 282, 284, 285, 287, 290, 292, 305, 306, 307, 311, 319, 321, 322, 323, 327, 330, 331, 333, 336, 337, 339, 342, Merejib	JN Late
26	Diorite, basic diorite, limestone, calcite	JNG/27, 48, 49, 93, 181, 184, 282, 298, 351, 356, 358	JN, once early, five times late
27	Diorite, basic diorite, limestone, calcite	JNG/22, 42, 62A, 94, 120, 182, 183, 234, 245, 298, 352, Bussokheir	JN Late
28	Diorite, basic diorite, limestone, calcite, steatite	JNG/22, 42, 147, 173, 174, 221, 244, 252, 270, 301, 351, 358	JN Late
29	Diorite, basic diorite	JNG/151, 229, 265	JN All periods
30	Diorite, basic diorite, limestone	JNG/42, 72B, 116, 158, 231, 249, 261	JN Late
31	Diorite, basic diorite, (evidently a copy of a metal form)	JNG/220, 221, 234, 246	JN, Middle and late
32	Diorite, steatite, (copy of metal form, cf. RC. Metal type 16)	JNG/221, 248, 298	JN Middle
33	Basic diorite	JNG/14	JN Late
34	Diorite, basic diorite	JNG/349	JN Early
35	Diorite, basic diorite, limestone	JNG/90, 176, 306, 320	JN All periods
36	Diorite	JNG/252, 357, Merejib	JN Middle and late
37	Calcite	JNG/360	JN Late
38	Diorite	Loose in soil amongst graves	JN
39	Diorite, basic diorite, limestone, calcite	JNG/116, 193, 200, 269, 341	JN All periods
40	Diorite, basic diorite, limestone, (two limestone examples with cattle reliefs)	JNG/53, 120, 128, 198, 211, 221, 242, 264, 330	JN All periods
41	Diorite, basic diorite, limestone	JNG/276, 279A, 289	JN Early

No.	Material, etc.	Provenance	Date
42	Limestone, calcite	JNG/221, 239	JN Late
43	Diorite, basic diorite	JNG/45, 289	JN Late
44	Limestone	JNG/280, 321, 349	JN All periods
45	Limestone	JNG/157, 210	JN Early
46	Basic diorite	Loose in soil amongst graves	JN
47	Limestone	Loose in soil amongst graves	JN
48	Limestone (white and pink), calcite, alabaster	JNG/194, 274, 287, 299	JN All periods
49	Limestone, calcite	JNG/186B, 197	JN Late
50	Diorite, limestone, marble, calcite, alabaster	JNG/5, 78A, 87, 197	JN Late
51	Calcite	JNG/246	JN Middle
52	Limestone, basic diorite	JNG/173, 242, 252, 263, 271, 286, 292, 302, 305(?), 325	JN All periods
53	Calcite	JNG/14, 306	JN All periods
54	Calcite, gypsum	JNG/337, 351, 353, 355	JN All periods
55	Calcite, alabaster	JNG/2, 42, 145	JN Late
56	Diorite, limestone, calcite, alabaster	JNG/144, 152, 221	JN Middle
57	Limestone, calcite, alabaster	JNG/42, 141, 154, 155, 157, 159, 219, 220, 221, 225, 227, 230, 233, 235, 237, 245, 251, 255, 259, 260, 261, 265, 278, 289, 290, 302, 308	JN One early example the rest middle and late
58	Calcite	Loose in soil amongst the graves	JN Middle and late
59	Limestone, calcite, alabaster	JNG/48, 74, 174, 179, 181, 184, 218, 226, 240, 246, 247, 248, 249, 261	JN Middle and late
60	Steatite	Loose in soil amongst the graves	JN (?)
61	Steatite	JNG/72B	JN Late
62	Limestone, alabaster	JNG/221	JN Middle
63	Diorite	JNG/221	JN Middle
64	Calcite	JNG/48, 197	JN Middle
65	Gypsum	Pit F, Sq. D4	JN Late

## APPENDIX VI

## ANALYSES

## A. CEMENT.

Two specimens of cement, (a) plaster from the wall of a Royal Tomb of the Early Dynastic Period and (b) a cement brick from Mereijib (*v. p.* 83) were submitted to Dr. H. J. Plenderleith of the British Museum Research Laboratory; he reported

Analytical Results:

3rd August, 1935

	Plaster obtained from wall of a Royal Tomb	Sumerian Brick
Siliceous minerals	26.86	30.55
CaO	24.10	20.24
MgO	Trace	1.53
Al <sub>2</sub> O <sub>3</sub> + Fe <sub>2</sub> O <sub>3</sub>	3.34	1.05
CO <sub>2</sub>	3.11	3.37
SO <sub>3</sub>	26.28	24.51
Loss on ignition (excluding CO <sub>2</sub> )	11.15	16.63
Alkalis and chlorides not estimated	—	—
	94.84	97.88

## B. BITUMEN.

I am indebted to the Shell Mex Company for detailed studies made in their laboratories of various specimens of bituminous products found at Ur.

(1) A fragment of an asphalt ring found in Pit F immediately above the Flood deposit. On this Messrs. J. E. Hackford, B.Sc., F.I.C., F.C.S., S. Lawson and P. E. Spielmann, Ph.D., F.I.C., B.Sc., reported in the *Journal of the Institution of Petroleum Technologists*, 1931, as follows:

The fragment weighs 3.31 g. and as it is evidently between one-half to one-third of the original object, the weight of the latter was probably about 8 g.

The freshly broken surface was friable and of a dull blackish-brown colour, and when a fragment was ground or streaked on paper it gave a chocolate-coloured powder.

A portion of the material was submitted to a series of selective solvents, with the following results: —

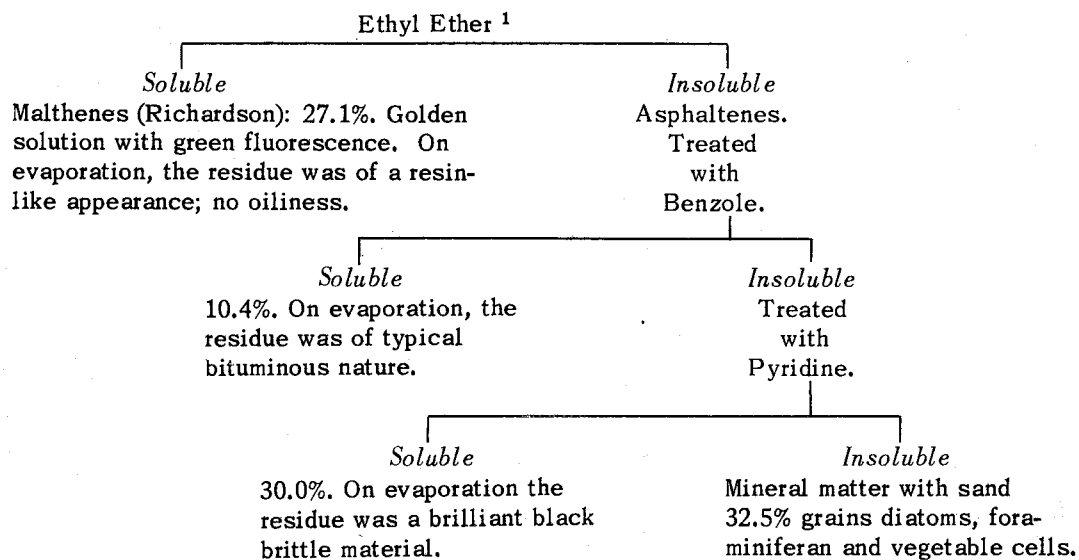

<sup>1</sup>The usual solvent employed, it will be remembered, is standard petroleum ether, but the use of ethyl ether gives closely similar results.

A chemical examination of the material gave the following results: —

	Per cent.
Bitumen, soluble in pyridine	63.7
Ash, intrinsic in the soluble bitumen	<u>3.8</u>
	67.5
Ash, insoluble in pyridine	27.4
CO <sub>2</sub> , equivalent to CaO in ash (see below)	1.9
Vegetable matter, etc. (by diff.)	<u>3.2</u>
	100.0

The sulphur content determined on the total bitumen soluble in pyridine was 7.9 per cent. This is not very different from the figure — 9.3 per cent. — obtained from a sample recently analysed from Qasat Ma'Moora, in Iraq.

The composition of the ash intrinsic in the soluble bitumen (3.8 per cent.) was determined spectroscopically (by Dr. S. Judd Lewis), and was found to contain: — Ag, Al, B, Ba, Ca (much), Cb(?), Cr (substantial), Fe (substantial), K, Li, Mg, Mn, Mo, Na (substantial), Ni, Pb, Rb(?), Si (much), Sr, Ti, Tl, V and Zn.

The mineral matter (27.4 per cent.) of the asphalt ring, taken for analysis, was obtained by ashing the pyridine-insoluble matter. It consisted of: —

	Per cent.
Insoluble siliceous matter	51.3
Fe <sub>2</sub> O <sub>3</sub> and Al <sub>2</sub> O <sub>3</sub>	7.3
CaSO <sub>4</sub>	34.2
CaO	7.1
V <sub>2</sub> O <sub>5</sub>	0.16
Ni (calculated as metal)	<u>0.014</u>
	100.074

Before ashing, the pyridine-insoluble material was found, on microscopical examination, to contain much sand, some diatoms, two types of foraminifera and well preserved vegetable fibres. After ashing, the most obvious objects, apart from sand grains, were the siliceous skeletons of the vegetable fibres.

The vegetable matter, 10 mm. and more in length, was found distributed throughout the mass of the ring. These fragments were obtained for microscopic examination by two different methods. In the first, the asphalt was softened by means of oil of eucalyptus, and the vegetable fragments were dissected out with fine needles, whereby undistorted specimens were obtained. A previous attempt to dissolve away the bitumen by means of warm benzole led to the disintegration of the fibrous material.

In the second method, the pyridine-insoluble matter after removal of the pyridine by means of chloroform and ether, was then mixed with an aqueous solution of erythrosine, which resulted in the lighter material floating to the surface of the water and, at the same time, the vegetable matter becoming stained with the dye. The dyed material was instantly recognisable under the microscope, and was removed with needles for examination under a higher power.

It was noticed, when a portion of the ring was heated, that the mineral matter accurately preserved the shape of the portion taken. Examination, both chemical and microscopical, shows this to consist mainly of sand and calcium sulphate, and their presence may be accounted for on a basis of observations by Mr. Woolley.

At the present time asphalt is collected near Hit as it comes to the earth's surface. Water rises with varying velocity, sometimes accompanied by so much gas that the latter will burn after being ignited. In the water are "snakes" of asphalt, which collect together and are consolidated by the natives by hand pressure into lumps, which are then thrown aside. After a very short time they become flattened owing to subsidence under their own weight. It is possible that the material was collected in the same manner in ancient times, because similar lumps of asphalt have been found at levels only slightly above that at which the asphalt ring was discovered. If this be so, it is not difficult to form a reasonable suggestion as to what occurred. The "snakes" of asphalt, in which was partially emulsified the saline water (which is usually associated with oilfields), dried in the air and under pressure, and thus received the 9.4 per cent. calcium sulphate found today. The mass was thrown on the ground whereby it picked

up the vegetable matter and some sand; it probably received a further and intentional admixture of sand up to the 27.4 per cent. found.

It is possible, but less likely, for the calcium sulphate to have penetrated the ring subsequently to its formation. Mr. Woolley has found large crystals of selenite in damp positions at deep levels. It is well known that water can penetrate mixtures of bitumen and sand, so that it is not impossible that this has happened in the present case where the penetration has been aided by "breathing" caused by variation of hydrostatic pressure exerted by the surrounding waters.

The presence of diatoms and foraminifera does not offer much useful evidence. The former are found equally in fresh and sea water; the latter are almost exclusively marine, but whether it is contemporaneous with the formation of the interim or is a subsequent addition, is impossible to say.

(2) On another small fragment apparently of the same or slightly later date Dr. R. J. Forbes, of Amsterdam, reported as follows; —

Haringvlietstraat 11,  
Amsterdam (Zuid)  
November 6th, 1934

Total weight 2500 mg.  
Bitumen content 41.5% by weight  
Vegetable and Mineral matter 58.5% by weight

Bitumen:

Totally soluble in pyridine.  
Only 56.4% soluble in CS<sub>2</sub>, therefore partially oxidized.  
9.2% Sulphur content, thus Mesopotamian origin certain.  
Tar compounds absent.

Vegetable and Mineral matter (very fine powder):

Chemical:

About 5 % siliceous skeletons of disintegrated rushes.  
49 % Silica  
2.4% Manganese  
2.5% Carbon dioxide  
3.6% Iron oxide  
36.3% Lime

Microscopical analysis:

Besides vegetable matter, much feldspar and calcite, some biotite and quartz.

Both vegetable and mineral matter (desert dust) probably gathered near spring of the bitumen, intentional admixture improbable and unsuitable if to represent a mastic.

(3) A large lump of asphalt showing on the underside the imprint of the basket in which it had been carried; found in Pit K, *circ.* level 5.50 m., in the upper part of the clean Flood deposit stratum. On this Dr. R. J. Forbes reported in the *Journal of the Institution of Petroleum Technologists* (Vol. 22, No. 149, p. 180) as follows; —

Note on a Lump of Asphalt from Ur

The reader of this journal will remember a note on an asphalt ring from Ur of the Chaldees, which appeared some years ago.<sup>1</sup>

Last year Sir Leonard Woolley when excavating the site of Ur found a big lump of asphalt embedded in what is known as the "Flood Layer". This lump was given by him to Mr. J. Kewley by whose courtesy it became an exhibit of the Institution of Petroleum Technologists. The exhibit consists of an irregularly shaped mass with a roughly circular cross-section, tapering slightly from top to bottom, and appears to be a conglomerate of a number of individual pieces which have fused together, stratified in places by thin layers of mineral matter. The central portion consists of a core of mineral matter akin to that originally covering the whole. The core contains both large and small fragments embedded in it. In several places it has been possible to dig deep cavities in the sample by remov-

<sup>1</sup>Hackford, Lawson and Spielmann (*J.I.P.T.*, Dec. 1931, p. 738).



ing mineral matter without disturbance of the asphalt, the material removed being similar to that remaining in the main central core.

The surface of the asphalt is speckled fairly uniformly by pockets of finely distributed mineral matter, the pockets varying in size from less than 1 mm. to as much as 10 mm. These pockets appear to persist throughout the mass since they are evident in most of the larger fragments broken off during cleaning and in a section of the exhibit which was cut down by about 10 mm. to a plane surface. Also embedded in the asphalt are fragments of what appear to be wood, reeds or rush-like materials. The surface of the asphalt is covered with a somewhat glossy outer layer or patina which flakes off readily, exposing a hard, friable asphalt.

The lump weighed about 10 kg. (diameter 11 in., height 5 in.) and during cleaning a sample of about 60 g. of fragments of asphalt and two samples of the mineral matter were collected. These two samples of mineral matter represent the dust removed from the large lump during cleaning, which had been sieved on a coarse sieve and thus split up into two fractions merely to facilitate hand-picking of asphalt fragments. This mineral matter represents, of course, the material which forms what is known as the Flood Layer.

The asphalt sample was submitted to the action of a series of selective solvents, viz. pyridine and chloroform, while each extraction was carried on until the extract was colourless. Then the solvent was removed and washed out by a short extraction with benzene. The extracts were collected and the solvent carefully evaporated on a water-bath and afterwards on an air-bath. It appeared that a large part of the asphalt was no longer soluble in even these powerful solvents and because it was imperative to clean the mineral matter before examining it, it was decided to follow a somewhat uncommon course.

After the CO<sub>2</sub> content of the remaining sample had been determined, it was subjected to a temperature of 350°C. on an air-bath for two days, in the course of which time the remainder of the organic material burned away slowly, leaving the carbonates unaltered, as was proved by checking this figure after the heating. The mineral matter was now ready for chemical and mineralogical examination. Unfortunately the sample was too small to enable any analysis to be made of the vegetable remains, which were clearly distinguishable in the bigger lump. As far as this examination goes, there is no difference with other samples formerly analysed.<sup>1</sup>

The composition of the asphalt sample is given in Table I.

TABLE I. COMPOSITION OF THE ASPHALT SAMPLE.

Bitumen content:

Soluble in pyridine, chloroform and benzene	39.5% by weight	
Insoluble organic matter	<u>37.0% by weight</u>	
		76.5% by weight
Mineral matter		23.5% by weight

Soluble Bitumen:

Sulphur content	6.8%
Ash content	1.0%
Vanadium in ash	positive
Nickel in ash	faintly positive
Diazo reaction in bitumen	negative

Hard and friable bitumen giving a deep brown streak on porcelain.

The evidence shows that this sample is a specimen of the native asphalt so common in the numerous seepages on the right bank of the Euphrates. It probably comes from the region of Hit where these seepages abound and where bitumen was won from them since untold centuries. The mineral matter content is far too low for a mastic and would seem to be just the wind-blown desert dust collected by the bitumen in or near the seepage.

<sup>1</sup> Forbes, R.J., "Untersuchungen betreffende die ältesten Anwendungen von Bitumen in Mesopotamien" (*Bitumen*, 1935, Heft I, p. 9).

From the description of the general appearance of the sample we must deduce that the lump was formed from smaller pieces thrown together and perhaps pressed together to remove, at least as far as possible, the water always included in these native asphalts from Mesopotamia. Sir Leonard suggested that it may represent the remains of a basket of asphalt ready for the preparation of a mastic for some form of constructional work. This would seem to be the case. The analysis and the fact that we have here a complex of smaller lumps not yet heated with mineral matter unevenly distributed through the sample would seem sufficient proof of this. On the other hand we have no exact description of the way of collecting bitumen in those early times, and so we do not know whether the raw material was transported in baskets, though it would seem quite probable.

This sample must therefore represent the crude native asphalt called ESIR-LAH by the Sumerians ("shining asphalt"), for the sample takes us back to the earliest times of Sumerian history and this people dates its first dynasty from the times of the Flood, a natural catastrophe mentioned in the Bible as Noah's Flood. There is still considerable difference of opinion on the question as to whether:

1. This barren Flood Layer (dividing the archaic remains from the historical period at Ur) is a product of the legendary Flood;
2. We may conclude that similar barren layers found during the excavation of other old towns were deposited together in one deluge or whether they represent local floods of different ages.

Even their date is still a matter of conjecture as long as Mesopotamian chronology is not yet settled. Anyhow, we are safe if we adopt the lowest estimate for the Ur flood. The asphalt sample found therein may thus be dated back to about 3200 B.C.

It was already stressed that we possess no old Sumerian text on the winning of bitumen<sup>1,2</sup> but we would like to draw attention to an Arabian text of an encyclopaedia by the Persian author al-Qazwini,<sup>3</sup> who gives the following information on bitumen:

"There are two kinds of al-kfir (native asphalt). First comes the kind that oozes from certain mountains; then we have the kind that appears with water in certain pools. It boils with the water and as long as they remain mixed the bitumen is soft; but if we separate them the bitumen hardens and becomes dry. It is collected by means of mats and thrown on the shore (of the seepage). Then it is brought in a kettle under which a fire has been lit, the sand is dissolved (?; mixed) and a certain amount added, and a mix prepared by constant stirring. When the mix is ready, it is poured on the floor, where it cools and hardens. Ships and bathrooms can be waterproofed in this way."

There is no doubt that this description of the bitumen industry of Mesopotamia in the middle of the thirteenth century shows that the old tradition lived on, for as we know this local industry is still lively,<sup>4</sup> and bitumen-coated "guffah" are still used for river-transport. The Sumerians clearly distinguished the different native asphalts from the mastic prepared therefrom, calling the latter ESIR-E-A ("house asphalt"). Here again we can find a proof that this sample was not a mastic. For there are two points in which asphalt and mastic differed in those times, namely in the price and the form in which they were sold.

If we compare different contracts in which we read about bitumen, we are struck by the fact that the mastic is always sold by volume, by the "Gur," the ancient measure for grain, beer, etc. Such is the evidence of ancient texts from the very same Ur.<sup>5</sup> Crude asphalt is always sold by weight by the "mina" or "shekel," as were metals and other solid commodities. This means that the mastic was prepared by heating the crude asphalt

<sup>1</sup>Forbes, R.J., *Op. cit.*, p. 9.

<sup>2</sup>Forbes, R.J., "Aus der ältesten Geschichte des Bitumen," (*Bitumen*, 1934, Heft 1, p. 6) and my forthcoming "Bitumen and Petroleum in Antiquity."

<sup>3</sup>Ruska, J., "Das Steinbuch aus der Kosmographie des al-Kazwini," (*Beil. zum Jahresber. Oberrealschule Heidelberg* 1895/96, p. 43).

<sup>4</sup>Schweer, W., "Die einheimische Erdölindustrie in Mesopotamien und Persien," (*Petroleum* XV, 1920, No. 10, pp. 397-399).

<sup>5</sup>Fish, T., "About Building in Ur III," (*Bull. John Rylands Library*, XVIII, 1934, No. 1, pp. 134-135).

and either selling it in these melting vessels (probably earthenware) or in the form of cakes, just like the modern mastic.

At the same time the custom seems to have been to prepare the mastic on the spot as contracts mentioning mastics are not very frequent and usually mention only small quantities when compared with those calling for crude asphalt.<sup>1</sup> The price of the mastic is something like double that of crude asphalt, which may be explained by the shortage of fuel in a treeless country like Mesopotamia.<sup>2</sup>

Summing up all the evidence we come to the conclusion that the sample is a lump of crude Hit asphalt which, as Sir Leonard supposes, may have been left over from some building activity. The analysis shows that the bitumen has hardened considerably, why is not clear. Other samples of ancient mastics did not show this feature, they were always completely soluble in pyridine. Perhaps the explanation lies in the damp position and the constant change of the water-level in the Flood Layer, though such hardening has not been noticed in other mastics from other parts of the country,<sup>3</sup> which were also exposed to very damp conditions.

The analytical data collected on the mineral matter from this sample are given in Table II. There are several points of interest in these figures.

TABLE II. COMPOSITION OF THE MINERAL MATTER

	A. Mineral Matter Extracted from Sample	Mineral Matter adhering to sample	
		B. Coarse Fraction	C. Fine Fraction
<u>Screen analysis:</u>			
On No. 10 sieve	2.7% by weight	3.6% by weight	— % by weight
20	3.3	9.4	—
30	2.4	6.3	0.8
40	2.9	6.4	2.8
50	4.0	4.2	3.3
80	5.3	8.0	24.6
100	1.0	0.4	0.6
200	9.8	22.3	26.8
<u>Particle size:</u>			
74-40 $\mu$	20.3	32.7	16.6
20-40	18.8	1.4	12.7
5-20	11.5	1.0	6.6
0-5	18.0	4.3	4.2
<u>Chemical analysis:</u>			
SiO <sub>2</sub> content	43.9	39.2	39.2
CaO	13.7	15.2	15.2
CO <sub>2</sub>	8.5	10.4	10.6

Mineralogical analysis:

The general composition of these three samples is the same; they consist mainly of quartz and calcite with smaller percentages of feldspar and muscovite, also a fairly high percentage of a limonitelike material. Sample A contains the least calcite of the three.

The residues obtained by the heavy mineral analysis show that all three samples are essentially similar, being characterized by the Augite-Hornblende-Epidote association.

<sup>1</sup>de Genouillac, *Inventaire des tablettes de Tello*, V (Paris, 1910) p. 1.

<sup>2</sup>See p. 162, footnote 2.

<sup>3</sup>Forbes, R.J., "Untersuchungen betreffende die ältesten Anwendungen von Bitumen in Mesopotamien" (*Bitumen*, Heft 1, p. 9).

First of all they show us that though the mineralogical character of the samples does not point to any marked difference, the mineral matter extracted from the asphalt is very much finer. Of course no great importance should be attached to the screen analysis of conglomerates like these samples, because during the test they disintegrate wholly or partly into the original particles. But the dust from sample A is much finer than the two samples from the Flood Layer, if we reckon only the very finest particles below 20  $\mu$ . These have the dimensions of the common clays and if therefore the wind-blown dust in the asphalt (sample A) is different from the mineral matter on the outer layers of the lump (samples B and C), the finest particles must have been washed or blown out of the latter.

For there is no reason why there should be any intrinsic difference. Sands from many spots in Mesopotamia from the desert, river-bed, and river-bank, were examined and they all show the same characteristics of the common desert sand, which in turn is derived from the erosion of the cretaceous ranges on the North and South borders of the country. None of these samples differs very much from this wind-blown sand, the grading is characteristic for aeolian sands which all have their main fraction within rather narrow limits (here roughly 150-40 $\mu$ ).

Secondly, for the very reason that these sands differ only in minor points, it is very difficult to make out whether they are fluvial, marine or aeolian deposits. It is interesting to read the analysis of samples of the Flood Layer and similar barren layers excavated in the ancient town of Kish; the results of which examination by V. Malycheff were published by Watelin.<sup>1</sup> These samples proved to be very rich in calcite and muscovite and contain much less quartz than the usual sand from other countries. On the other hand, microscopical examination of the fossils proved that they contain mostly cretaceous foraminifera. No characteristic marine or fluvial fossils were found, which again proves that all these Mesopotamian deposits find their origin in the desert sand which may have been transported by the rivers (or by the wind) to a secondary spot. Malycheff found sulphates and chlorides present in the water-soluble part of the sands, a fact which we were able to confirm.

We must therefore point out that as these "Flood Layers" which have been found in several excavations in ancient Mesopotamian towns are not at all characteristic clay or sand deposits differing from the present desert sand, it will be difficult to decide whether their origin is fluvial, marine or aeolian on the strength of some chemical or mineralogical analyses only, and the local conditions (topography, etc.) should be taken into account to decide this point.

The author wishes to thank Dr. Fulcher and Mr. Buwalda for their kind help in collecting the analytical data and the Bataafsche Petroleum Maatschappij for their permission to publish these notes.

I would refer also to Dr. Forbes' article "The Nomenclature of Bitumen, Petroleum, Tar and Allied Products in Antiquity" published in *Mnemosyne* and again to his invaluable monograph, *Bitumen and Petroleum in Antiquity*; in the latter there are many references to material from Ur belonging to the archaic periods, e.g. Figs. 40, 42, 44, 48, 51.

### C. METAL.

#### (1) Copper.

On a number of examples of copper from the Jamdat Nasr graves Dr. C.H. Desch reported as follows in the Sixth Interim Report of the Sumerian Committee of the British Association (1935):—

In the earlier reports, many of the specimens were indicated only by British Museum numbers, sometimes with the addition of 'early' or 'late.' In the full publication of Sir Leonard Woolley's results from Ur,<sup>2</sup> the analyses carried out by the Committee, with a few additions, are tabulated in chronological order by Dr. Plenderleith. It thus appears that the single object of the al'Ubad period so far found is of nearly pure copper; that of eleven objects from the Royal Cemetery, nine are bronze, whilst two contain only small proportions of tin, that both copper and bronze occur in the Sumerian period, but that objects of the Sargonid period are either of copper or contain a very small proportion of tin. A bar of copper is described as of the 'Sumerian revival, c. 2500 B.C.'

<sup>1</sup>Watelin, L. Ch., "Essai de coordination des périodes archaïques de la Mesopotamie et de l'Elam," *L'Anthropologie*, XLI, 1931, p. 271.

<sup>2</sup>*Ur Excavations*, II, *The Royal Cemetery*, 1934.

Several vessels obtained by Sir Leonard Woolley from the Jamdat Nasr level at Ur have now been analysed, with the following results:

	1	2	3	4
	Per cent.	Per cent.	Per cent.	Per cent.
Copper	48.18	55.59	55.66	67.23
Nickel	trace	0.02	—	0.075
Arsenic	0.65	0.20	0.39	0.93

Tin was absent.

On account of the highly corroded state of these specimens, it was not considered safe to calculate the composition of the original metal, but all may be described as arsenical copper. The first two contained much chloride, and were embedded in soil containing large quantities of soluble chlorides and sulphates, but no trace of tin, which might have been extracted from the metal, was found. Specimens 1 and 2 contained sulphur, indicating a pyritic ore, but this was absent from 3 and 4. The amount retained by the metal would be accidental, and liable to vary greatly in successive casts.

A copper rod sent with one of the vessels (Jamdat Nasr level), and marked PG, Pit W, JNG, was less corroded, and gave on analysis:

Copper	82.33 per cent.
Tin	—
Nickel	0.05
Arsenic	0.34
Sulphur	0.11

To this Dr. Desch added a further note in a letter of December 4th, 1935.

As all the specimens were corroded completely through, I did not venture to calculate the composition of the original metal, as this may have changed in the process of corrosion. However, it is quite clear that all the specimens are of arsenical copper; on the assumption that the composition has not changed by corrosion, the proportions of arsenic would be 1.3, 0.36, 0.7, 1.35, and 0.41 per cent. respectively: the nickel figures are low. These analyses, therefore, differ entirely from those of the later period at Ur, which we have analysed for you before, as these had little or no arsenic, and the nickel was rather more constant. The present analyses would fit very well assource from the North, such as Anatolia or Armenia, where undoubtedly arsenical copper ores occur with a little nickel.

#### (2) Lead.

An analysis of one of the lead tumblers from the Jamdat Nasr graves made by Mr. E. C. Padgham of the British Museum Research Laboratory gave the following results:—

100 grams lead gave 0.0255 grams silver, approximately 9 oz. silver to the ton.

#### D. THE FLOOD DEPOSIT.

Three specimens of the silt were submitted to the Petrographical Department of the Geological Survey; two of them, labelled Z and Y, came from Pit F, that labelled X from Pit A. Dr. U. U. Thomas reported on them as follows:—

The soil specimens and silts have been examined and I find *Specimen Z* is a fine grained, closely laminated silt, the laminae showing definite current-bedding and grading of particles. On a cross-section certain laminae may be seen to wedge out in a manner that can only be accounted for by the action of gentle currents. In a distance of two inches the laminae may tail off from a thickness of one or two millimetres to the merest film. The average thickness of the laminae is something less than a millimetre. The silt has a definite parting parallel to the surfaces of the laminae, which are seen to be covered with the minutest scales of detrital mica.

In constitution the material is mainly fine angular quartz with much finely divided mica, fairly abundant green hornblende with some augite and magnetite. The particles are somewhat variable in size, as would be suggested by the lamination of the sediment. They range up to 0.1 mm. but mostly they have much smaller dimensions.

*Sample X.* Has practically the same constitution and texture as *Z* except for the absence of lamination.

*Sample Y.* A fine clay material with particles mainly under 0.01 mm. and highly micaceous. It is quite possibly water deposited, for it would be difficult to account for it in any other way.

The absence of lamellation might suggest wind-blown dust, there is a complete absence of any larger rounded particles which usually occur in aeolian deposits.

The material of *X* and *Y* appears to be derived in part from a series of hornblendic and augitic igneous rocks.

## APPENDIX VII

## CATALOGUE OF OBJECTS

This catalogue has been made as succinct as possible.

Plain clay vessels and metal objects found in graves and adequately described with type numbers and measurements in the grave analyses are omitted, as are numerous objects of little intrinsic importance found in conditions which did not supply evidence for accurate dating. Cylinder seals have been published in Vol. X of this series, a reference to which obviates further description.

Capital letters in brackets show to which Museum each object was allotted – (B) = Baghdad, (L. *BM.*) = London, British Museum, and (P) = Philadelphia. Where the Museums have supplied their own registration or catalogue numbers these also are quoted. (L) means that the object was allotted to London but has been presented by the Trustees of the British Museum to some other public museum.

The following abbreviations are used for sites –

- PFG/ . . . . . Graves of the al 'Ubaid period (*v.* Appendix II)  
 JNG/ . . . . . Graves of the Jamdat Nasr period (*v.* Appendix III)  
 PJ/B . . . . . Graves of the Royal Cemetery period (*v.* Appendix IVa)  
 PJ/G . . . . . Graves of the Sargonid period (*v.* Appendix IVb)

and the following for the type series of clay and stone vessels –

- aU = Types of the al 'Ubaid period, *v.* Pls. 51-53.  
 JN = Types of the Jamdat Nasr period; Pls. 65-67, stone vases, and Pls. 56-64, clay vases.  
 RC = Types of the Royal Cemetery and Sargonid periods; Pls. 68, 69 and Vol. II, *The Royal Cemetery*, Pls. 223-267.

For inscriptions the abbreviation *R.I. No.* . . . is to *Ur Excavations, Texts*, Vol. I, *Royal Inscriptions*, by C. J. Gadd and L. Legrain, with the number allotted in that volume. References to other volumes of the Ur archaeological series give the number of the volume only.

- U.94 Fragment of a vase of white calcite in the form of a seated ram; highly stylised work, probably of the Sargonid period. Of the animal the head, chest and right shoulder remain, with part of the hollow in the back. Ht. 0.09 m., present l. 0.09 m. Found under the Kuri-Galzu floor in E-nun-mah. Pl. 42. (L. *BM.* 116460.)  
 U.127 Flint arrow-head, leaf-shaped, very finely chipped, l. 0.045 m. (tip missing); surface find. Pl. 13.  
 U.178 Statuette in red sandstone of a seated bull; the head missing; in the back a cup-like hollow as if to take the tenon of a figure of a god standing on the bull. Good work, probably of the Sargonid age. Ht. 0.07 m., l. 0.13 m. Found under the Kuri-Galzu floor of E-nun-mah. Pl. 42. (L. *BM.* 116459.)  
 U.181 Stud or nail of translucent grey obsidian; tip broken; l. 0.021 m. Pl. 15.  
 U.197 Fragment of a mace-head of grey schist. The surface is covered with an engraved pattern originally inlaid. Ht. 0.06 m., diam. 0.16 m., diam. of hole 0.06 m. Found under the Kuri-Galzu floor of E-nun-mah. Pl. 35. (L. *BM.* 116458.)  
 U.206 Mace-head, fragment of, white calcite, with rope moulding in relief and inscription of Rimush, *R.I.* No. 10. Ht. 0.19 m., diam. 0.21 m. Found under the Kuri-Galzu floor of E-nun-mah. (P. *CBS.* 14932.)  
 U.207 Mace head, of white calcite; the top moulding chipped. Inscribed "Rimush King of Kish." Ht. 0.14 m., diam 0.14 m. Found under the Kuri-Galzu floor of E-nun-mah. (P. *CBS.* 14932.)  
 U.210 Stone bowl, fragment of; of black steatite; carved in low relief on the outside are figures of long-horned oxen; of one the head is missing but the entire body and one horn remain, of the second only part of the hind quarters; in this case the tail is short and curly and the animal may be other than an ox. Ht. 0.075 m., width 0.15 m., orig. diam. of bowl 0.145 m. Found in the ruins of E-nun-mah. Pl. 36. (L. *BM.* 116456.)  
 U.211 Fragment of a cup of black steatite; carved in low relief on the outside a figure of a boar standing on its hind legs with one front foot resting on a conventional mountain; crude but vigorous work. The foot of the cup was made of a separate piece of stone. Actual ht. 0.125 m., width of frag. 0.07 m. Found under the Kuri-Galzu floor of E-nun-mah. Pl. 36. (P. *CBS.* 14967.)

- U.221 Mace-head, fragment of, of green quartzite, 0.095 m. x 0.09 m. inscribed, *R.I.* No. 6. Found under the Kuri-Galzu floor of E-nun-mah. (P. *CBS.* 14396.)
- U.224 Vase, fragment of, in dark steatite; carved in relief on the outside is a figure of a god kneeling on his left knee and holding up two vases of water; each vase is grasped round the neck by the hand of an otherwise missing figure, so that the design must have been repeated all round the vase. Very fine and bold work in the style of the best Sargonid cylinder seals. Ht. 0.044 m., width of fragment 0.052 m. Found under the Kuri-Galzu floor of E-nun-mah. Pl. 35. (B. 402.)
- U.231 Vase, fragments of, in dark steatite; carved in relief on the outside is a mythological scene shewing a two-headed monster grasping the horns of an ibex, a second figure fighting a serpentine beast, a lion, a scorpion, fish, etc. On the inner face remains of an inscription, *R.I.* No. 9. Original ht. c. 0.15 m., diam. 0.18 m. Found under the Kuri-Galzu floor of E-nun-mah. Pl. 36. (*L.BM.* 116455.)
- U.232 Vase, fragments of, of white limestone. On the 3 fragments (of which 2 fit together) there are carved in relief a seated goddess with 2 children and a standing god with 5 standing figures of adorants; also remains of an inscription, *R.I.* No. 7. Original ht. c. 0.11 m., diam. 0.19 m. Found under the Kuri-Galzu floor of E-nun-mah. Pl. 36. (*L.BM.* 116432.)
- U.237 Bull's head in white calcite, being the front decoration of a rectangular trough-shaped bowl; the stone in bad condition and the head restored from fragments. The eyes were inlaid and the ears and horns of a different material. Ht. 0.12 m. Found under the Kuri-Galzu floor of E-nun-mah. Pl. 42. (P. *CBS.* 14965.)
- U.239 Bowl, fragment of, of black steatite. The outside was surrounded by a row of reclining bulls carved in low relief but with the heads projecting virtually in the round. One bull and the hind-quarters of a second remain. The body of the animal and the field are inlaid with trefoils, dots, the sun and the moon in white shell; below are the ends of 6 lines of inscriptions undecipherable. Very fine work, v. pp. 32, 52. Ht. 0.04 m., width 0.10 m., original diam. 0.12 m. Found under the Kuri-Galzu floor of E-nun-mah. Pl. 35. (P. *CBS.* 14968.)
- U.245 Stone vase, fragment of; white limestone; inscribed, *R.I.* No. 25. Found under the Kuri-Galzu floor of E-nun-mah. (*L.BM.* 116457.)
- U.251 (and U.253) Stone vase, fragments of, inscribed by a king of the dynasty of Akkad, name missing; *R.I.* No. 8. Found under the Kuri-Galzu floor of E-nun-mah. (*L.BM.* 116435.)
- U.258 Vase, two fragments of, in white calcite, roughly inscribed in primitive script, *R.I.* No. 3. Found under the Kuri-Galzu floor of E-nun-mah. (*L.BM.* 116439.)
- U.263 Vase, fragment of, in white calcite, with inscription of Rimush of Akkad, *S.A.K.I.* p. 162, Vase C. Found under the Kuri-Galzu floor of E-nun-mah. (*L.BM.* 116436.)
- U.264 Vase, fragments of, in white calcite, inscribed "Rimush, king of the World." Found under the Kuri-Galzu floor of E-nun-mah. (B. 113.)
- U.272 (plus U.286) Stone bowl, fragments of, in white calcite, with inscription *R.I.* No. 4. Found under the Kuri-Galzu floor of E-nun-mah. (*L.BM.* 116431.)
- U.273 Stone vase, fragment of, in black and white marble, with inscription *R.I.* No. 25. Found under the Kuri-Galzu floor of E-nun-mah. (*L.BM.* 116446.)
- U.282 Vase, fragment of, in grey steatite, inscribed with the name of Naram-Sin. Found under the Kuri-Galzu floor of E-nun-mah. (P. *CBS.* 14951.)
- U.284 Mace-head, fragment of, in white calcite, inscribed "Naram-(Sin?)," 0.095 m. x 0.08 m. Found under the Kuri-Galzu floor of E-nun-mah. (P. *CBS.* 14937.)
- U.302 Box-lid (?) of white steatite, circular, with 2 holes pierced from side to side to take the strings which fastened down the lid; the top is carved with an 8-petalled rosette of which the petals were originally inlaid. Diam. 0.06 m. Found under the Kuri-Galzu floor of E-nun-mah. (P. *CBS.* 14956.)
- U.449 Vase, fragments of, in coarse white marble; round the outside was carved in low relief a design of water-pots with water flowing symmetrically out of them. Found under the Kuri-Galzu floor of E-nun-mah. Pl. 36. (P. *CBS.* 14963.)
- U.601 Shell inlay in the form of an eagle with wings and talons outspread; the head missing and one wing and one talon broken. Very fine work. Orig. ht. c. 0.025 m. Surface find from SE of the Temenos. Pl. 28.
- U.602 Celt, polished, of greenish pebble; ht. 0.04 m. E-nun-mah. Pl. 14.
- U.609 Clay model wheel with scalloped rim and projecting hub round which are indented holes. Diam. 0.09 m. Found against the SW face of the Temenos Wall of Nebuchadnezzar. Pl. 16.
- U.651 Clay figurine, hand-modelled, of a bull, the horns and all the hinder part of the body missing; it is of greenish drab clay with markings painted in black, normal al 'Ubaid ware. Total l. 0.10 m., ht. 0.08 m. Found against the SW face of the Temenos Wall of Nebuchadnezzar. Pl. 23.
- U.654 Beads; 128 small carnelian rings, 38 white pebble tubular and 12 small lapis ovals. Found with stone bowls U.810-U.830 at Bussokheir. (*L.BM.* 116577.)
- U.805 Statue, diorite, of Entemena, the head missing, inscribed on shoulders and back. *R.I.*, No. 1. Ht.



- 0.76 m. Found on the Nabonidus pavement before the inner doorway of the gate under the Ziggurat in the Nebuchadnezzar Temenos Wall. Pl. 40. (B.5.)
- U.810 Stone bowl, basic diorite, Type JN.23, ht. 0.045 m., diam. 0.134 m. From Bussokheir near Tell Halawiyeh. (B.256.)
- U.811 Stone bowl, basic diorite, Type JN.21, ht. 0.035 m., diam. 0.12 m. Bussokheir. (B.257.)
- U.812 Stone bowl, basic diorite, Type JN.27, ht. 0.09 m., diam. 0.155 m. Bussokheir. (B.258.)
- U.813 Stone bowl, schist, Type JN.17, ht. 0.035 m., diam. 0.082 m. Bussokheir. (B.259.)
- U.814 Stone bowl, basic diorite, Type JN.17, ht. 0.03 m., diam. 0.083 m. Bussokheir. (P. *CBS.* 14980.)
- U.815 Stone bowl, basic diorite, Type JN.9, ht. 0.09 m., diam. 0.12 m. Bussokheir. (B.260.)
- U.816 Stone bowl, basic diorite, Type JN.23, ht. 0.03 m., diam. 0.092 m. Bussokheir. (L. *BM.* 116477.)
- U.817 Stone bowl, basic diorite, Type JN.22, ht. 0.096 m., diam. 0.195 m. Bussokheir. (P. *CBS.* 14981.)
- U.818 Stone bowl, schist, Type JN.22, ht. 0.07 m., diam. 0.135 m. Bussokheir. (L. *BM.* 116473.)
- U.819 Stone bowl, fragment of, blue-grey mottled steatite (?), ht. 0.032 m., diam. 0.085 m. Bussokheir.
- U.820 Stone bowl, coarse white limestone, Type JN.12, ht. 0.05 m., diam. 0.105 m. Bussokheir. (P. *CBS.* 14979.)
- U.821 Stone bowl, mottled pink marble, Type JN.19, ht. 0.053 m., diam. 0.125 m. Bussokheir. (B.261.)
- U.822 Stone bowl, coarse grey limestone, Type JN.13, ht. 0.057 m., diam. 0.155 m. Bussokheir. (L. *BM.* 116472.)
- U.823 Five roundels of green stone, flat below and convex above, perhaps lids for vases; average diam. 0.04 m. Bussokheir. (L. *BM.* 116478.) (P. *CBS.* 14955.)
- U.824 Stone mortar, of fairly hard greenish grey stone, Type RC.18, ht. 0.09 m., diam. 0.115 m., depth 0.03 m. Bussokheir. (B.262.)
- U.825 Stone pestle, of hard whitish limestone, l. 0.125 m., greatest diam. 0.04 m. Bussokheir. Pl. 13. (B.263.)
- U.826 Shell rings, 13, found with the stone pots U.810-U.825. (B.443.)
- U.827 Beads; 9 shell tubular, much decayed, the longest 0.07 m. long; some small shell rings; small natural shells pierced for threading; one mother-of-pearl hexagonal spacer pierced at each end; half a dozen small carnelian rings. Found with the stone vases at Bussokheir. (B.444.)
- U.828 Flints; small saw-edged flakes; found with the stone vases U.810-U.825 at Bussokheir. (B.449.)
- U.830 Clay pot, spouted, with scored decoration at the base of the neck and rippled moulding round edge of shoulder. Ht. 0.17 m. Found with the stone vases U.810-U.825 at Bussokheir. (P. *CBS.* 15384.)
- U.896 Figure of a lion, fragment of, in white calcite, the greater part of the body and part of the mane preserved, the head missing; the lion, carved in the round, is recumbent and seems to have been attached to the rim of a very large vase. Ht. 0.06 m., l. 0.06 m. Found under the Kuri-Galzu floor of E-nun-mah.
- U.897 Mace-head, fragment of, in white calcite, carved in high relief with the mane of a lion. Measurements 0.08 m. x 0.07 m. Found under the Kuri-Galzu floor of E-nun-mah.
- U.916 Figurine, white limestone, of a recumbent doe, the head turned over the right shoulder, l. 0.033 m., ht. 0.02 m. Found on the surface about 400 m. E of Diqqiqqeh. Pl. 28. (B.325.)
- U.1141 Head of a snake, in green pebble; pierced for attachment to a body, or for suspension, l. 0.029 m. Surface find, E. of city wall. (B.578.)
- U.1285 Amulet, of polished black stone. Two rams (?) seated side by side, full face, the heads in low relief, the bodies denoted by incised lines. Pierced vertically for suspension. Ht. 0.036 m., width 0.039 m. Diqqiqqeh. (P. *CBS.* 15591.)
- U.1405 Clay figurine, fragment of; nude female figure, hand-modelled, preserved from the waist to the ankles; al 'Ubaid type. Ht. 0.062 m. Found in the filling of the great Nannar court under the Nebuchadnezzar pavement. Pl. 21. (L. *BM.* 117136.)
- U.1439 Amulet, shell, in the form of a couchant lion; pierced for suspension, l. 0.021 m. Diqqiqqeh. (L. *BM.* 119239.)
- U.1555 Amulet, haematite, in the form of a seated cat (?); pierced for suspension, l. 0.019 m. Diqqiqqeh. Pl. 28. (L. *BM.* 116790.)
- U.1621 Amulet, shell, in the form of a pig's head. Ht. 0.018 m. Diqqiqqeh. Pl. 28. (B.786.)
- U.1622 Stone bowl, of fine-grained green stone, Type JN.8, ht. 0.105 m., diam. 0.13 m. From Abu Kumbareh. (P. *CBS.* 15803.)
- U.1623 Copper harpoon, l. 0.125 m. From Abu Kumbareh. Pl. 30. (B.787.)
- U.1658 Statue, diorite, fragment of. Part of the face of a life-size human figure, from the top of the neck to the base of the nostrils and back across the right cheek to below the ear; the mouth is complete and the chin nearly so. Very fine work of the best "Gudea" type. Found on the NW side of the central staircase of the Ziggurat, below the Neo-Babylonian level. Pl. 42, v. p. 51. (P. *CBS.* 15609.)
- U.2509 Amulet, shell, in the form of a seated bull (or lion?), roughly carved: pierced from front to back. Ht. 0.015 m., l. 0.025 m. Surface find. Pl. 28. (B.867.)

- U.2531 Human head, shell, carved in the round: a clean-shaven male head, miniature, the neck pierced laterally as if for suspension, but perhaps for fixing to a body made of a different material. Ht. 0.022 m. Diqdiqqeh. Pl. 44. (B. 875.)
- U.2573 Pin, of white calcite; point missing, l. 0.044 m. Diqdeqqeh. Pl. 15. (B.894.)
- U.2577 Fragments of a monument in blue-grey schist with remains of inscription; 0.111 m. x 0.073 m. *R.I.* No. 20. Found near the NW side of the Ziggurat.
- U.2638 Fragment of a calcite vase; in low relief part of a lion standing on conventional rocks. Ht. 0.075 m. Ziggurat terrace, NW side. Pl. 36. (B. 902.)
- U.2666 Flint arrow-head, leaf-shaped, finely chipped; l. 0.04 m. In the filling of the great Nannar court. Pl. 12. (B. 2666.)
- U.2717 Ear-stud of fine dark grey baked clay, type as Pl. 15, U.17764; ht. 0.01 m., diam. 0.03 m. In the archaic level at the back of Dublal-mah.
- U.2732 Statue, of basic diorite, of a seated man, the head missing and the body seriously damaged; in the photograph the restorations are the left shoulder, the left arm and much of the surface of the drapery over the lower part of the body. On the right shoulder is an inscription, *R.I.* No. 11, "Dada-ilum; protection of Sin" (?). Both the name and the other words are Semitic and Dada-ilum is presumably an Akkadian; several *Dada* diviners of the time of Naram-Sin are known. Ht. 0.42 m. Found in a room between E-nun-mah and Dublal-mah. Pl. 41. *V.* p. 47. (L.BM. 119063.)
- U.2744 Flint arrow-head, leaf-shaped, very finely chipped, l. 0.047 m. Dublal-mah, surface soil. Pl. 12. (L. BM. 119268.)
- U.2745 Flint arrow-head, flat and barbed, well chipped; l. 0.036 m. Dublal-mah, surface soil. Pl. 12. (B. 927.)
- U.2756 Stone vase, fragment of, in white calcite, inscribed. *R.I.* No. 18. Found on the NW side of the Ziggurat terrace in the Larsa ruins. (B. 933.)
- U.2764 Amulet, white limestone, in the form of a seated animal, ht. 0.01 m., l. 0.017 m. Diqdiqqeh. Pl. 28. (L. BM. 119195.)
- U.2805 Nail or stud of white obsidian, with flat head, tip missing, l. 0.023 m. Archaic level against NW side of Ziggurat. Pl. 15. (B. 949.)
- U.2806 Nails or studs, two, of bitumen; one broken. L. 0.042 m. Archaic level against NW side of Ziggurat. Pl. 15. (L. BM. 119265-6.)
- U.2807 Fragment of vase of black obsidian, finely polished. Archaic level against NW side of Ziggurat. (L. BM. 119083.)
- U.2818 Terra-cotta figurine of a pig, head missing; hand-modelled in red clay with details rendered in dark red paint. Ht. 0.05 m., l. 0.072 m. Archaic level against NW side of Ziggurat. Pl. 21. (L. BM. 119150.)
- U.2819 Clay model of a sickle, greenish drab ware with the cutting edge and the ends of the blade painted black. L. 0.072 m. Archaic level against NW side of Ziggurat. (L. BM. 119153.)
- U.2826 Shell plaque, pierced at the back for inlay; on the front an engraved design of two figures advancing l.; both are crowned and have long hair, 0.029 m. x 0.026 m. Archaic level against the NW side of Ziggurat. Pl. 38. (L. BM. 119247.)
- U.2827 Celt, of dark blue-grey stone, finely polished. l. 0.036 m. Diqdiqqeh. Pl. 14. (B. 956.)
- U.2981 Celt, of green schist, angular in section; l. 0.039 m. Surface find. Pl. 14. (B. 992.)
- U.3058 Amulet, shell, in the form of a couchant lion; pierced from front to back, l. 0.02 m., ht. 0.008 m. Diqdiqqeh. Pl. 28.
- U.3070 Flint arrow-head, barbed, well flaked; l. 0.034 m. Surface. Pl. 13.
- U.3104 Statue, diorite, fragment of: the lower part of the body of a figure wearing the *kaunakes*, the feet missing. Ht. 0.20 m. In the filling of the courtyard of Dublal-mah. (B. 1029.)
- U.3105 Clay foundation-cone of Gudea, with dedication to Nina. *Cf. S.A.K.I.* p. 142, Backstein H. In the filling above the late temple of Nin-Gal. (L. BM. 119025.)
- U.3127 Celt, of dark blue stone, pierced at the top; l. 0.073 m. In the late Nin-Gal temple. Pl. 14. (B. 1037.)
- U.3157 Amulet, of pink marble, in the form of a human hand; l. 0.03 m. From Sakheiri. Pl. 28. (L. BM. 119255.)
- U.3158 Votive stela, diorite, fragment of; inscribed with a dedication to Nin-Gal by Ur-(Nammu) for the life of Utu-ḫegal king of Erech. *R.I.* No. 30. Found under the pavement in the late temple of Nin-Gal (B.1048.)
- U.3173 Votive stela, white limestone, fragment of: at the top a crescent moon and sun, below an inscription, probably by Ur-Nammu, to Nannar for the life of Utu-ḫegal king of Erech. *R.I.* No. 31. Found in the surface soil close to the late temple of Nin-Gal. (L. BM. 119064.)
- U.3198 Celt, of mottled black and brown stone, polished; l. 0.049 m., width 0.036 m. Surface find. Pl. 14. (L. BM. 119074.)

- U.3208 Shell inlay, fragment of a square plaque, shewing feet and *kaunakes* skirt of a figure in profile facing left. 0.015 m. x 0.014 m. Diqiqqeh. Pl. 44. (L. *BM.* 119246.)
- U.3225 Stamp seal, square, of dark steatite, with pyramidal top; design of a spread eagle. 0.017 m. sq. Diqiqqeh. Pl. 44. (L. *BM.* 119212.)
- U.3244 Foundation-tablet, steatite, with dedication by Gudea of a temple called E-lal-tum to Nindar. Found below the pavement of the late temple of Nin-Gal. *R.I.* No. 28. (L. *BM.* 119012.)
- U.3278. Shell inlay, fragment of; part of the flounced *kaunakes* skirt of a large figure, probably from wall decoration. Ht. 0.105 m., width 0.072 m. Found on the Sin-balatsu-iqbi pavement of the late temple of Nin-Gal. Pl. 44. (B. 1093.)
- U.3279 Stone vase, white obsidian, fragment of; found on the Sin-balatsu-iqbi pavement of the late temple of Nin-Gal. (L. *BM.* 119082.)
- U.3291 Stone vase, diorite, fragment of, inscribed with a dedication by Rimush king of Kish. *R.I.* No. 9. From the late temple of Nin-Gal. (B. 1098.)
- U.6056 Fragment of inlay, black steatite, part of a flounced *kaunakes* skirt, 0.05 m. x 0.021 m. Loose in the top soil of EH. Pl. 44. (L. *BM.* 118567.)
- U.6104 Amulet, of grey pebble, in the form of a phallus; l. 0.03 m. Date doubtful. Diqiqqeh. Pl. 27. (P. *CBS.* 16367.)
- U.6155<sup>a,b</sup> Two truncated cones of unbaked clay, ht. 0.225 m., base diam. 0.143 m. On one side of each, just above the base, are two deep oblong depressions set close together like owl's eyes. They seem to be crude examples of the 'eye idol.' Site EH, Sq. S5. Depth 2.00 m. They stood side by side. (B. 1533.)
- U.6170 Terra-cotta figurine of a boar, hand-modelled, ht. 0.04 m. Found in upper soil. Pl. 21. (B. 1587.)
- U.6192 Amulet, shell, in the form of a boar's head. L. 0.016 m. Loose in the top soil of EH. Pl. 28. (B. 1392.)
- U.6311 Stone vase, white marble, fragment of, with part of a dedication by Gudea to the goddess Nin-mar-ki. *v. R.I.* No. 26. Loose in the top soil of EH. (B. 1155.)
- U.6332 Stone vase, white calcite, fragment of, with dedication to A-SI(G) by Nin-me-ta-bar-ri son of An-sir (cf. An-sir king of Mari). *R.I.* No. 12. From EH, sq. R8. (P. *CBS.* 16208.)
- U.6333 Stone vase, white calcite, fragment of, with part of inscription of Rimush, *R.I.* No. 22. From EH, Sq. N8. (P. *CBS.* 16518.)
- U.6355. Stone cup, Type RC.16c, black and white granite, with inscription, *R.I.* No. 24. Found in the ruins of the Gig-par-ku of Nin-Gal. (L. *BM.* 118553.)
- U.6361 Stone vase, fragment of, white calcite, with inscription of the son of Ur-bau, *patesi* of Lagash; *R.I.* No. 25. Found in the ruins of the Gig-par-ku of Nin-Gal. (L. *BM.* 118558.)
- U.6365 Stone vase, fragment of, white calcite, with inscription round the flat top of the rim; *R.I.* No. 16. Found in the ruins of the Gig-par-ku of Nin-Gal. (L. *BM.* 118594.)
- U.6410 Alabaster relief, silhouetted and carved in low relief on both sides. It represents a boat made of reeds tied at the ends and brought up to form a high prow; the stern is broken away; amidships is a shelter formed of reeds bent over in the form of an arch. On one side there is a figure of a naked man standing by the prow, his head missing, and under the shelter is a pig; on the other side there is a goose under the shelter and two fish hang by the prow. Rough archaic work. Ht. 0.045 m., l. 0.06 m. Found with U.6756, etc., in a *cache* below the Kassite houses SE of the Gig-par-ku. Pl. 38. (B. 1178.)
- U.6417 Head, limestone, broken off below the neck and the back of the head missing; male figure, perhaps a priest. Ht. 0.08 m. From the house ruins SE of the Gig-par-ku. Pl. 42. (L. *BM.* 118563.)
- U.6419 Terra-cotta figurine of an animal, hand-modelled, ht. 0.037 m. From the upper soil over the Larsa house site. Pl. 21. (P. *CBS.* 16276.)
- U.6429 Baked clay tool (?) in the form of a crescent; l. 0.055 m., thickness 0.002 m. Cf. Pl. 45, U.14938. From under the house ruins SE of the Gig-par-ku. (L. *BM.* 124458.)
- U.6444 Female head in black diorite. The hair, rendered by wavy lines, is looped at the sides and raised in a chignon at the back. Left eye and brow damaged. Ht. 0.083 m. Found in the ruins of the Gig-par-ku. *V.* p. 52. Pl. 43. (L. *BM.* 118564.)
- U.6463 Semi-circular bar of white marble, U-shaped with flat ends and having near each end a small hole bored through the stone on the diameter of the semi-circle: diam. of bar 0.03 m., inner diam. of circle 0.077 m. It resembles the loop ornament figured in early sculptures on the jambs of doors or on spears set up by doors; the ends of the stone might fit into holes in a wooden upright or come against the flat face of the wood, and the small holes would serve for attachment by means of copper wires: Pl. 44. Found with U.6410, etc., in a *cache* under the Kassite house ruins SE of the Gig-par-ku. (L. *BM.* 118587.)
- U.6468 Amulet, or pendant, crystal, in the form of a claw (?), the tip missing. L. 0.043 m. From EH, 2.00 m.-3.00 m. below the floor of the Dungi temple of Dimin-tabba. Pl. 28. (L. *BM.* 118648.)

- U.6470 Stone bowl, lime stone, Type RC.48, ht. 0.048 m., diam. 0.096 m. Found in a *cache* under the Kassite house SE of the Gig-par-ku. (B.2795.)
- U.6473 Amulet, or pendant, pink marble, in the form of a duck (? or claw); very crude; l. 0.024 m. From the house ruins SE of the Gig-par-ku. Pl. 27. (B. 1402.)
- U.6478 Amulet, shell, in the form of a seated bull, the body carved in profile, the head turned outwards over the shoulder: l. 0.022 m., ht. 0.025 m. From EH, 1.00 m. below the floor of red clay, Sq. R 9. Pl. 27. (P. CBS. 16349.)
- U.6480 Two silver bangles and a number of silver beads corroded together. Site EH, loose in soil. Pl. 30. (L. BM. 118602.)
- U.6486 Amulet, calcite, in the form of a seated bull; rough work; l. 0.014 m., ht. 0.014 m. From EH, sq. M 9, in a plano-convex brick building. Pl. 28.
- U.6487 Amulet (?), shell, in the form of a human leg, pierced below the knee: ht. 0.018 m. From EH, archaic level below the Dungi temple. Pl. 28. (L. BM. 118655.)
- U.6488 Marble palette (?) convex on one side, having rounded corners with a hole through each. 0.104 m. x 0.07 m. x 0.012 m. Found in a *cache* under the Kassite house SE of the Gig-par-ku. (B. 16848.)
- U.6489 Stone vase, in white and yellow streaked alabaster, Type JN.14; ht. 0.112 m. Site EH, room in Sq. N 9. (L. BM. 118583.)
- U.6500 Stamp seal, calcite, rectangular with pyramidal top; seated figure drinking. From EH, sq. R 9. (B.)
- U.6501 Stamp seal, shell, in the form of a seated bull; on the flat base a crudely cut design of a winged beast and a crescent, l. 0.015 m. Surface find. (L. BM. 118646.)
- U.6504 Amulet, shell, in the form of a seated lion; l. 0.018 m. Loose in the soil in EH, Pl. 28. (L. BM. 118644.)
- U.6525 Stone tool, l. 0.10 m. From EH, archaic level. Pl. 13.
- U.6540 Stone tool, black pebble, l. 0.10 m. From EH, archaic level. (B. 1160.)
- U.6550 Gaming-piece of black steatite, square, one face inlaid originally with five white dots. 0.02 m. sq. From EH, archaic level. (P. CBS. 16352.)
- U.6551 Die; a cube of shell, 0.005 m. cube, the sides marked with incised dots. From EH, archaic level. Fig. 7(a). (L. BM. 118656.)
- U.6556 Miniature peg of baked clay, the upper end decorated with stamped circles. L. 0.028 m. From below the house ruins SE of the Gig-par-ku. Pl. 15. (B. 1435.)
- U.6560 Celt, of green stone, l. 0.033 m., width 0.033 m. Diqdiqqeh. Pl. 14. (P. CBS. 16361.)
- U.6575 Amulet, of mottled shell, in the form of a kidney (?); l. 0.025 m. Diqdiqqeh. Pl. 27. (L. BM. 118647.)
- U.6578 Fragment of a human head carved in the round in grey limestone; only the left half of the head remains and the nose and mouth are badly mutilated. The head is clean-shaven, the face full, the ear heavy; traces of bitumen remain in the eye-sockets. Ht. 0.14 m. From the Gig-par-ku. Pl. 42. (B. 1177.)
- U.6580 Clay vase, fragmentary, Type RC.243, with criss-cross pattern incised below the mouth. From EH, in the archaic level below the primitive terrace wall. (B. 1256.)
- U.6596a Shell plaque, part of, with engraved design of a bull plunging in marshy ground amongst water-plants. Ht. 0.029 m., l. 0.055 m. Loose in the soil on the Gig-par-ku site. Pl. 38. (P. CBS. 16347.)
- U.6605 Celt, of green stone, resembling U.6560; l. 0.02 m., width 0.03 m. Below the foundations of the Kassite buildings over the Gig-par-ku. (B. 1442.)
- U.6612 Disk of white calcite, diam. 0.26 m.; on one side is a panel wherein is carved in relief a scene of sacrifice, on the other an inscription of Enheduanna, daughter of Sargon of Akkad. v. p. 49. Found in a chamber of the Larsa temple of Nin-Gal (the Gig-par-ku). V. R.I. No. 23. Pl. 41. (P. CBS. 16665.)
- U.6614 Fragment of a white calcite figure of a reclining bull carved in the round; the head missing, l. 0.13 m. Found in the Gig-par-ku below the Kuri-Galzu pavement. (B. 1165.)
- U.6673 Cow's horn carved in black steatite, the surface characterised by minute parallel wavy lines: l. 0.026 m. Found in the filling of the great Nannar courtyard.
- U.6691 Votive stela, blue-grey limestone, fragment of. In part of an upper register 3 male figures wearing the *kaunakes* and facing left, the heads destroyed; in a lower register remains of 2 female figures facing left, preserved to the breast only and much damaged; by them traces of an inscription in archaic linear script of the Ur-Nina type. Early work with plentiful use of the drill. Ht. of male figures 0.08 m. Found in the Gig-par-ku, in the upper filling of a chamber on the SW side. The inscription reads ". . . ka he has filled abundantly, the *E-ana-ka* he has replenished." R.I. No. 13. Pl. 41. (P. CBS. 16682.)
- U.6702 Stone cup, fragment of, obsidian, inscribed; R.I. No. 15. Found in the ruins of the Gig-par-ku of Nin-Gal. (B. 1176.)
- U.6727 Plaque, fragment of, in bituminous limestone, carved in relief and inscribed; the plaque was originally rectangular and pierced by a square hole in the centre. Of the relief there remains only part

- of a scene of a man fighting with a gazelle, and a bird; for the text *v. R.I.* No. 14. Found in the ruins of the Gig-par-ku of Nin-Gal. Pl. 41. (B. 1182.)
- U.6737 Brick-stamp, part of, steatite, with remains of inscription. *R.I.* No. 21. Found near the palace of Ur-Nammu, loose in upper soil. (P. *CBS.* 16210.)
- U.6756a,b Two *protomoi* of rams in grey gypsum; the heads and fore parts of the bodies are carved in the round, the back part is left rough; probably the supports of a throne. L. 0.62 m. and 0.57 m. respectively, ht. 0.37 m. Found in a *cache* with U.6410, 6795, etc., under the Kassite houses SE of the Gig-par-ku. Pl. 38. (P. *CBS.* 16569.)
- U.6776 Stone vase, white calcite, Type JN.19, inscribed "En-an-ni-pad-da priest of Nannar, son of Ur-bau *Patesi* of Lagash." *R.I.* No. 25. Ht. 0.19 m., diam. 0.14 m. In debris of the Larsa level, Gig-par-ku. (B. 1170.)
- U.6782 Female head, alabaster, broken off at the neck; nose and lower part of face damaged; the eyes inlaid. Ht. 0.092 m. *V.* p. 52. Site EH, loose in soil. Pl. 43. (P. *CBS.* 16228.)
- U.6795 Beads; double comoids and balls of paste and lapis lazuli and gold with gold pendants, Pl. 29. Found with U.6756, etc.
- U.6796 Beads; carnelian rings and tubes. Found with U.6795, etc.
- U.6797 Pendant, silver, set with lapis lazuli, diam. 0.035 m. Found with U.6795, etc. Pl. 29.
- U.6798 Beads; lapis lazuli double comoids. Found with U.6795, etc.
- U.6799 Finger-ring, silver, a hoop of slightly concave plate between raised rims; found with U.6795, etc. (P. *CBS.* 16369.)
- U.6800 Pendant, silver, of embossed and filigree work, diam. 0.04 m. Found with U.6795, etc. Pl. 29. (P. *CBS.* 16370.)
- U.6801 Pendant from a necklace, silver wire coiled into twin disks, l. 0.024 m. Found with U.6795, etc. Cf. Vol. II, Pl. 134, U.9656.
- U.6802 Beads, silver and lapis-lazuli, with one ball and one ring of paste originally glazed. Found with U.6795.
- U.6831 Plaque of white limestone pierced with a square hole in the centre and decorated on one face with two scenes carved in relief, one above the other. In the upper register a scene of libation, a king with his three children and a draped priest before a shrine; in the lower, a naked priest pouring a libation at an altar, a priestess and two attendants carrying animals for sacrifice. Archaic style. Measurements 0.26 m. x 0.22 m. x 0.02 m. thick. Found in the Gig-par-ku of the Larsa period, in a chamber on the NE side. Pl. 39. *V.* p. 45. (L. *BM.* 118561.)
- U.6857 Human head carved in grey limestone, fragment of. Part of the hair and the upper half of the face down to the nose alone remain. The hair is rendered by fine wavy lines, hangs in a fringe over the forehead and is gathered behind in a double chignon; the eyebrows are rendered by feathered lines, the eyelids are sharply defined and the eyeballs are protuberant. Ht. 0.05 m. Found in debris of the Larsa period towards the south corner of the Gig-par-ku. (B. 1180.)
- U.6862 Celt, grey stone, resembling U.6560. L. 0.06 m. Loose in the filling of the Gig-par-ku. (B. 1443.)
- U.6870 Stone knife, black steatite, crescent-shaped with projections at the ends for attachment, (one broken away). L. 0.083 m., width 0.043 m. A somewhat similar type occurs in Susa I. In the filling of the Larsa period Gig-par-ku. Pl. 13. (B. 1404.)
- U.6877 Knife (?) of baked clay, perhaps a model of a stone original; crescent-shaped and curved, with incised markings on the concave face. In the Kassite level, Gig-par-ku.
- U.6926 Amulet, of mottled greenish marble, in the form of a seated bull, pierced through the middle of the body. L. 0.031 m., ht. 0.022 m. Near the SE foot of the Ziggurat. Pl. 27. (P. *CBS.* 16350.)
- U.6957 Clay foundation-cone inscribed "To *Dumuz-abzu* his (. . . .) *Gudea patesi* of Lagash his house in *Girsu* has built." *V.R.I.* No. 27. Found loose in the filling of Ur-Nammu's palace, NE part. (B. 1607.)
- U.7027 Stamp seal steatite, of Indus Valley type, Vol. X. No. 626. From a plundered grave. (P. *CBS.* 16301.)
- U.7067 Amulet of pink steatite, in the form of a seated bull; l. 0.016 m., ht. 0.011 m. *Diqdiqqeh.* Pl. 28. (L. *BM.* 118645.)
- U.7072 Stone vase, black steatite, fragment of. On the outside was a battle scene carved in relief; there remain only the lower part of the back of the *kaunakes* skirt and a foot of a standing figure and against this the head of a bearded warrior apparently fallen to the ground. Fine work in the style of the Agade period. 0.033 m. x 0.027 m. Surface. Pl. 36. (P. *CBS.* 16348.)
- U.7144 Human head, male, carved in the round in pink limestone, the back broken off; the head is clean-shaven, the features markedly individual. Ht. 0.07 m. Found in the ruins of the Larsa houses of the EM group. Pl. 42. (B. 1181.)
- U.7145 Fragment of bowl of dark steatite having on the outside a row of scorpions carved in low relief. Ht. 0.05 m., orig. diam. c. 0.07 m. Found above the Larsa houses of the EM group. Pl. 35. (P. *CBS.* 16657.)
- U.7560 Figure in mottled marble of a reclining bull; head missing; the bull rests on the top of a hollow

- cylindrical fragment which may be part of the spout of a stone vessel; such an arrangement would find parallels in vases of the Jamdat Nasr period found at Warka. L. 0.033 m., ht. 0.02 m. Found in the filling of a house on the NW side of Quiet Street. Pl. 42. (B. 3493.)
- U.7590 Knife handle (?) of black steatite, in the form of a boar's head; behind the head is a flat tang pierced with 2 holes for attachment. L. 0.06 m., ht. of head 0.017 m. Surface. Pl. 27. (P. CBS. 16762.)
- U.7600 Figure of a lion, in white limestone, the body alone preserved: the animal was couched with the head resting on the forelegs; a hole in the body seems intended to receive a tenon perhaps of a figure which stood on the back of the lion. Ht. 0.056 m. Loose in upper soil. Pl. 41. (P. CBS. 17195.)
- U.7665 Human head, for inlay, in grey stone; carved in low relief, the back flat. The eyes were originally inlaid, the beard was added in a different material. Ht. 0.021 m. Diqdiqqeh. (P. CBS. 17763.)
- U.7683 Stamp seal, mottled grey steatite, rectangular with tubular handle above; design of a buffalo with bent head, in the Mohenjo-daro style. 0.025 m. x 0.023 m. Vol. X. 631. Brought in from the neighbourhood of Diqdiqqeh. (L. BM. 120573.)
- U.7686 Terra-cotta figurine of a dog (?), in dark greenish clay with details rendered in black paint; al 'Ubaid technique. Ht. 0.045 m. Sakheireh. Pl. 23. (B. 3558.)
- U.7807 Stone vase, white calcite, fragment of, with inscription of Rimush; *R.I.* No. 10. Found under the Nebuchadnezzar pavement of E-Nun-Mah. (B. 3578.)
- U.7916 Stamp seal, oval, of grey calcite. Found under the Nebuchadnezzar floor of E-Nun-Mah. Vol. X. 16. (P. CBS. 16906.)
- U.7917 Stamp seal, of grey calcite. Found under the Nebuchadnezzar floor of E-Nun-Mah. Vol. X. 17. (P. CBS. 16905.)
- U.8292 Head of a man in unbaked clay, hand-modelled in the round with a hole underneath for attachment to a body; there are traces of black paint round the eyes. Ht. 0.12 m. Found in the Royal Cemetery area, in the rubbish into which the graves were cut, on the same level as PFG/108 and 2.00 m. away from it. Pl. 24. (P. CBS. 17196.)
- U.8322 Terra-cotta figurine of an animal, hand-modelled, ht. 0.04 m. Royal Cemetery area, in the rubbish against the grave PFG/163. (B. 3801.)
- U.8348 Three terra-cotta figurines of animals, one complete, l. 0.05 m., ht. 0.046 m., the other two broken; hand-modelled. In the soil in which the Royal Cemetery was made, above PFG/213. Pl. 24. (P. CBS. 17228-9.)
- U.8472 Limestone head, carved in the round, of a clean-shaven man. The face has been destroyed and only the back of the head and the ears remain; there is a hole below for attachment to a body. Ht. 0.11 m. Royal Cemetery area. Pl. 24. (P. CBS. 17197.)
- U.8640 Terra-cotta figurine, hand-modelled in reddish clay, the surface covered with a haematitic wash. Crude representation of a female figure, the body being merely an oval and the head scarcely differentiated; the eyes are rendered by oblique slits, there is slight modelling of face and breasts and punctured dots represent a necklace. Ht. 0.085 m. Found in the Royal Cemetery area, between 5.50 m. and 6.00 m. below the surface. Pl. 23. (P. CBS. 17215.)
- U.9322 Terra-cotta figurine, hand-modelled, of a pig, the bristles of the body rendered by incised zigzag lines; ht. 0.04 m. l. 0.075 m. Royal Cemetery area, in the rubbish used for levelling above the Sargonid graves. Pl. 24.
- U.9549 Terra-cotta figurine, hand-modelled, of a sheep (?); ears and legs broken: ht. 0.052 m., l. 0.09 m. On one flank an inscription "Nam- (?) Overseer of Nannar." Royal Cemetery area at 2.60 m. below the surface, not connected with any grave, Pl. 21. (P. CBS. 17201.)
- U.10400 Dark grey limestone head, carved in the round, of a clean-shaven man, ht. 0.045 m. The nose damaged. A hole below for attachment to a body. Royal Cemetery area, upper soil. Pl. 42. (B. 8990.)
- U.11231 Obsidian nail or stud, with shaft square in section and flat head; l. 0.017 m. From rubbish above the Kuri-Galzu pavement in the great courtyard of Nannar. (P. CBS. 16909.)
- U.11400 Inlay, fragment of limestone relief for; the upper part of the figure of a man with arms raised holding a pole as if punting a boat. Ht. 0.07 m. Found in the filling of the great courtyard of Nannar, under the Nebuchadnezzar pavement. Pl. 39. (P. CBS. 17198.)
- U.11829 Flint arrow-head, tanged and barbed, l. 0.03 m. Surface. Pl. 13. (L. BM. 124470.)
- U.11954 Mace-head of pink marble, decorated with two bands in relief with coiled ends. L. 0.07 m., diam. 0.05 m. In the filling of a chamber in the Neo-Babylonian Temenos wall by the Royal Cemetery area. Pl. 44.
- U.11960 Obsidian pendant, rectangular, with handle at the top; ht. 0.031 m., width 0.02 m. Surface. Pl. 44. (B. 8891.)
- U.12326 Shell inlay, fragment of: upper part, to the waist, of the figure of a Sumerian soldier wearing a

- helmet and a skin garment and carrying a battle-axe. All incised lines were originally filled with black paste. Ht. 0.045 m. With it were found large fragments of slate from the background in which the shell had been set, cf. the Kish plaques, Langdon, *Kish*, Vol. I. Pls. XXXVI-XLIII: also a large triangle of mother-of-pearl, ht. 0.072 m., base 0.062 m. Found loose in the soil between 4.00 m. and 5.00 m. down in the Royal Cemetery area. Pl. 38. (B.8237.)
- U.12499 Terra-cotta figurines of animals, 26 in all, crudely hand-modelled, from the rubbish strata underneath the Royal Cemetery. (B. 29723-33 and 30916-17.)
- U.12500 Terra-cotta figurines of human beings, five in all, fragmentary, crudely hand-modelled, from the rubbish stratum underneath the Royal Cemetery. Pl. 23. (L. *BM.*) (P.31.17.324.)
- U.12613 Terra-cotta figurine, crudely hand-modelled in "snow-man technique"; ht. 0.06 m. From the rubbish stratum underneath the Royal Cemetery.
- U.12749 Bitumen figurine, crudely hand-modelled, of a seated or kneeling human figure; ht. 0.105 m. From the rubbish stratum underneath the Royal Cemetery. Pl. 23. (L. *BM.* 124465.)
- U.12750 Terra-cotta figurine, crudely hand-modelled, of a man in the attitude of prayer; head and body below waist missing. Ht. 0.045 m. From the rubbish stratum underneath the Royal Cemetery. Pl. 23. (B.45375.)
- U.12751 Terra-cotta figurine, fragment of; head of a ram (?) crudely hand-modelled, l. 0.065 m., al 'Ubaid style. In the rubbish stratum underneath the Royal Cemetery, depth c. 8.50 m. Pl. 22. (L. *BM.* 124468.)
- U.12752 Terra-cotta figurine, fragment of; head of an animal, crudely hand-modelled; ht. 0.07 m. In the rubbish stratum underneath the Royal Cemetery, depth c. 9.00 m. Pl. 24. (P.31.16.989.)
- U.12759 Terra-cotta figurine of a dog (?), crudely hand-modelled, ht. 0.04 m., l. 0.055 m. In the rubbish stratum underneath the Royal Cemetery. Pl. 24. (L. *BM.* 124467.)
- U.12764 Terra-cotta figurine, fragment of; skirt of draped human figure, well modelled in greenish clay and finely smoothed; probably al 'Ubaid period. Ht. 0.05 m. From the rubbish stratum underneath the Royal Cemetery. Pl. 23 (P.31.17.323.)
- U.12766 Bead; clay imitation of a long tubular bead made from the core of a conch shell (cf. Pl. 27, U.19247), the spiral markings reproduced. Pit G, 4.75 m. below the plano-convex brick pavement. (L. *BM.* 122588.)
- U.12767 Seven clay figurines of animals, crudely hand-modelled. Pit G, at 3.50 m. to 5.00 m. below the plano-convex brick pavement. (P.31.17.745-7, 750-2.)
- U.12768 Fragment of basic diorite, perhaps from a vase, with plant design carved in relief, 0.06 m. x 0.02 m. From Pit G. at 5.00 m. below the plano-convex brick pavement. Pl. 36. (L. *BM.* 124460.)
- U.12770 Clay figurine, fragment of; female figure, nude, preserved from below the breasts to the knees. Hand-modelled. Ht. 0.068 m. Pit G, 3.50 m. below the plano-convex brick pavement. Pl. 22. (L. *BM.* 124469.)
- U.12271 Clay seal-impression with naturalistic design of animals, Fig. 12.d; from Pit G; at about 4.00 m. below the plano-convex brick pavement. With it were a miniature bowl of white calcite, Type RC.112, ht. 0.018 m., diam. 0.036 m.; a basic diorite jar-lid (?) Fig. 12.b; a rough bowl of basic diorite, ht. 0.026 m., diam. 0.08 m.; and a miniature clay goblet, ht. 0.04 m., Fig. 12.e. (L. *BM.* 124459 and P.31.17.319.)
- U.12272 Clay figurine of an animal, the hind-quarters missing; details painted in black in the al 'Ubaid style. Ht. 0.06 m., l. 0.08 m. From Pit G, at 4.50 m. below the plano-convex brick pavement. Pl. 23. (P.31.17.322.)
- U.12773 Brick, of baked clay, rectangular, l. 0.21 m. x 0.115 m. x 0.075 m. From the bottom of Pit A. v. pp. 2, 52. (L. *BM.* 129078.)
- U.12775 Clay vase with two mouths, drab clay, ht. 0.105 m. Pit G, 6.00 m. below the plano-convex brick pavement. Fig. 12,a. (P.31.17.366.)
- U.12777 Paint; a clay pot-base containing some of the plum-red paint used by the potters. Pit G, 7.60 m.-8.00 m. below the plano-convex brick pavement.
- U.13052 Fragment of a steatite vase on which is a donkey's head carved in relief. From the rubbish stratum in the Royal Cemetery area. Pl. 36. (P.31.16.485.)
- U.13505 Terra-cotta figurine of a dog, crudely hand-modelled; ht. 0.028 m., l. 0.034 m. From the rubbish stratum underneath the Royal Cemetery. (L. *BM.* 123540.)
- U.13606 Clay foundation-cone of Entemena. Found loose in the soil.
- U.13680 Fragment of a white calcite vase inscribed with the beginning of a dedication by *BARA-enlil-gar-ra*. From the Royal Cemetery area, at a depth of 2.00 m.
- U.13701 Copper tool, Pl. 30; l. 0.157 m., the tool seems to have been cast and subsequently hammered to sharpen the two edges. Pit F, sq. E7, Stratum A. (B. 23465.)
- U.13702 Whetstone, of grey stone, square in section with bevelled angles, pierced for suspension; l. 0.113 m. Pit F, sq. E7, Stratum A.
- U.13703 Cylinder seal, shell, one end chipped; l. 0.053 m., diam. 0.01 m. Formal 'embroidery' design.

- Pit F, Stratum A. (L. *BM.* 122831.)
- U.13705 Upper and lower grindstones, of dark grey lava; the lower is a saddle quern, 0.30 m. x 0.13 m.; the rubber is set in bitumen for convenience of holding. Pit F, sq. F8, Stratum A. (B. 13705; L. *BM.* 129084.)
- U.13707 Palette, of grey pebble, flat and roughly circular, diam. 0.08 m. Pit F, sq. C5, Stratum A. (L. *BM.* 129083.)
- U.13708 Clay jar with nicked ornament on rim and a band of combed decoration round the shoulder. Ht. 0.23 m. Fig. 8. From Pit F, sq. D8, Stratum A, in the packing of a First Dynasty drain. (P. 31.17.370.)
- U.13709 Fragments of clay offering-table, ht. 0.45 m., rim diam. 0.31 m. Round the base incised chevrons and cross-hatched triangles; in the stem two long vertical slits on either side of which are the looped-staff doorway symbols; on one side a tree and the dotted pubic triangle, on the other side a tree and a house (?) either built on piles or with channelled masonry in the lower part of its walls. Found in a First Dynasty rubbish-pit in Pit F. (L. *BM.* 128551.)
- U.13711 Cylinder seal, shell, Vol. X. No. 55. Pit F, sq. D4, 1.50 m. below modern surface. (P. 31.17.15.)
- U.13712 Cylinder seal, marble, Vol. X. No. 83. Pit F, sq. D8, 1.50 m. below modern surface. (L. *BM.* 123625.)
- U.13713 Model boat, in bitumen, l. 0.08 m., roughly hand-modelled with slightly upturned prow and stern. Pit F, sq. D8, Stratum A. (L. *BM.*)
- U.13714 Stone bowl, half of; roughly made of dark grey steatite; rimless variant of Type RC. 112. Ht. 0.032 m., diam. 0.16 m. Pit F, sq. C7, Stratum A. (P. 31.16.371.)
- U.13716 Fragment of obsidian disk (vase-lid?), original diam. 0.08 m. thickness 0.001 m. Pit F, sq. C8, Stratum B. (P. 31.16.517.)
- U.13717 Stone bowl, fragment of, in basic diorite; below the rim is a band of rope-pattern in low relief from which rise imitation loop handles. Ht. 0.023 m., diam. 0.05 m. Pit F, sq. E8, Stratum B. Pl. 44. (P. 31.16.483.)
- U.13719 Clay disk, diam. 0.06 m., thickness 0.01 m. The flat edge is grooved horizontally and notched; there is a hole through the centre. Pit F, Stratum A. Pl. 16. (P. 31.16.494.)
- U.13720 Clay figurine of an animal, crudely hand-modelled, burnt black. Ht. 0.036 m. Pit F, top soil. Pl. 24.
- U.13722 Stamp seal of translucent white quartzite, Vol. X, No. 4. Pit F, sq. E5, Stratum A. (P. 31.17.24.)
- U.13724 Celt, polished, of black pebble, the edge damaged; l. 0.045 m. Pit F, sq. C5, Stratum B. Pl. 14. (P. 31.16.476.)
- U.13726 Cylinder seal, shell, Vol. X, No. 164. Pit F, sq. E5, Stratum A. (B. 14532.)
- U.13731 Amulet of black stone in the form of a dog; l. 0.029 m. Pit F, surface soil. Pl. 24. (B. 20494.)
- U.13732 Stone vase, miniature, of white limestone, Type RC.72, ht. 0.025 m., diam. 0.043 m. Pit F, sq. C7, Stratum D. (L.)
- U.13733 Bone roundel engraved with a cross on one side; diam. 0.03 m. Pit F, Stratum C. Pl. 16. (P. 31.17.85.)
- U.13735 Stone bowl, basic diorite, Type RC.15a; ht. 0.025 m., diam. 0.07 m. Pit F, sq. F6, Stratum D.
- U.13737 Stone bowl, basic diorite, Type RC.22a; ht. 0.025 m., diam. 0.085 m. Pit F, sq. E8, Stratum E. (P. 31.16.407.)
- U.13740 Stone lamp, basic diorite; a shallow bowl with trough spout, ht. 0.02 m., diam. 0.07 m. Pit F, sq. E8, Stratum E. (B. 23401.)
- U.13741 Stone bowl, basic diorite, Type JN.22; ht. 0.095 m., diam. 0.21 m. Pit F, sq. C5, Stratum E. (P. 31.16.376.)
- U.13742 Clay rattle, ht. 0.105 m., diam. 0.105 m. Pit F, sq. C5, Stratum F.
- U.13743 Clay funnel, Type RC.17, with a band of rope pattern in relief round the body; ht. 0.21 m. Pit F, sq. D6, Stratum D. (P. 31.16.217.)
- U.13744 Beads; shell rings, 2 shell spacers, small lapis and carnelian rings and 2 large carnelian rings. Pit F, sq. D6, Stratum F. (P. 31.17.103 & 145.)
- U.13745 Beads; small shell rings strung in 2 loops held together by a rectangular black steatite spacer. Pit F, sq. D6, Stratum F.
- U.13746 Stone vase-lid (?) of basic diorite; a shallow bowl, part cut away, pierced by 2 small and one larger holes for the strings to keep it in position. Diam. 0.075 m. Pit F, sq. D6, Stratum F. Cf. Fig. 12, b. (P. 31.16.489.)
- U.13747 Stone vase-lid (?) of basic diorite, exactly like U.13746. Pit F, sq. C7, Stratum E.
- U.13749 Roundel (spindle-whorl?) of dark grey steatite, the top slightly convex and engraved with radial lines; diam. 0.074 m. Pit F, Stratum E. Pl. 16.
- U.13753 Stone bowl, white limestone, Type JN.14, ht. 0.05 m., diam. 0.17 m., broken in antiquity and mended with 3 rivets. Pit F, sq. E6, Stratum E. (B. 16873.)



- U.13754 Stone bowl, white limestone, Type JN.22, ht. 0.037m., diam. 0.10m. Pit F, sq. D7, Stratum E. (P.31.16.453.)
- U.13755 Stone bowl, white limestone, Type JN.22, ht. 0.055 m., diam. 0.145 m. Pit F, sq. D7, Stratum E. (P.31.16.451.)
- U.13756 Stone bowl, white limestone, Type JN.15, ht. 0.11 m., diam. 0.27 m. Pit F, sq. D7, Stratum E. (P.31.16.434.)
- U.13757 Stone bowl, white limestone, Type JN.19, ht. 0.065 m., diam. 0.20 m. Pit F, sq. D7, Stratum E. (P.31.16.435.)
- U.13763 Bead, carnelian, rectangular, with bleached pattern. Pit F, *circ.* level 12.60 m. Pl. 28.
- U.13765a Stone bowl, diorite, Type JN.36; ht. 0.15 m., diam. 0.155 m. Mereijib.
- U.13765b Stone bowl, diorite, Type JN.4; ht. 0.15 m., diam. 0.145 m. Mereijib. (P.31.16.370.)
- U.13766 Stone bowl, diorite, Type JN.25; ht. 0.105 m., diam. 0.25 m. Mereijib.
- U.13767 Stone bowl, diorite, Type JN.24; ht. 0.098 m., diam. 0.235 m. Mereijib. (L. *BM.* 123747.)
- U.13768 Stone bowl, white limestone, Type JN.24; ht. 0.75 m., diam. 0.17 m. Mereijib.
- U.13769 Stone bowl, diorite, Type JN. 4; ht. 0.12 m., diam. 0.13 m. Mereijib. (B. 16872.)
- U.14168 Clay dedication-cone of Gudea mentioning the E<sup>d</sup>En (gur-ka-lum) temple of Nina. Found on the surface, EH site.
- U.14407 Amulet, of white stone, in the form of a standing calf, carved in the round and pierced behind the shoulder for suspension; the eyes were inlaid and the shell ring of one eye-ball is preserved. Ht. 0.023 m. Pit F, sq. D5, Stratum F or G. Pl. 27. (P.31.17.86.)
- U.14408 Model in baked clay of a saw (?); broken. L. 0.15 m. There seems to have been a solid handle which is broken away. From the rubbish of the Royal Cemetery area. Pl. 16. (P.31.16.593.)
- U.14414 Mace-head, of baked clay, oviform with vertical fluting; the clay is drab in colour but charred black on the inside; the surface is covered with a wash of plum-red paint. Orig. ht. 0.08 m., diam. 0.06 m. Pit F, sq. C6, Stratum H. Pl. 15. (P.31.16.757.)
- U.14415 Copper tool, a narrow chisel or engraver, with round stem flattened to the blade; l. 0.07 m. Pit F, sq. D6, Stratum H. Pl. 30. (P.31.17.249.)
- U.14418 Clay pot, Type JN.52 (the type example), pink body clay with creamy drab surface, band of red paint above the shoulder with vertical streamers in sets of three. Ht. 0.09 m. Pit F, sq. C7, Stratum H. (P.31.17.299.)
- U.14420 Stone bowl, veined limestone, Type JN.9, ht. 0.07 m., diam. 0.045 m. Pit F, sq. D6, level 10.70 m.
- U.14422 Vase, fragments of, of white frit originally covered with a blue glaze, now much decayed; an impressed chevron ornament round the shoulder. So far as the decayed state of the frit allows of judgment, the vase was moulded round a core which was subsequently removed. Ht. prob. c. 0.06 m., rim diam. 0.046 m. Pit F, level 10.80 m. Fig. 9.
- U.14423 Fragment of a terra-cotta figurine of a nude female, in green clay with detail painted in black; ht. 0.033 m. Pit F, sq. C6, level 10.00 m. Pl. 22. (L. *BM.*)
- U.14424 Fragment of a terra-cotta figurine of a nude female, in green clay with details in black paint; preserved from below the breasts to the knees. Ht. 0.044 m. Pit F, sq. D6, level 10.00 m. Pl. 22. (P.31.16.739.)
- U.14430 Clay stand (?), of greenish drab clay, with a band of crinkled ornament round the edge; Type JN.160. Pit F, sq. D7, level 10.20 m. (L. *BM.* 124487.)
- U.14431 Brick, kiln-fired, triangular with 2 straight and one curved edges, the top face slightly concave; sides l. 0.15 m., 0.075 m. thick. Pit F, sq. C8, level 10.80 m. Fig. 9.
- U.14434 Terra-cotta figurine of a nude female, crudely hand-modelled in red clay; head and one shoulder missing. Ht. 0.03 m. Pit F, level 11.00 m. Pl. 24. (L. *BM.* 124487.)
- U.14435 Terra-cotta figurine of a nude female, crudely hand-modelled with incised lines for necklace; head missing; ht. 0.044 m. Royal Cemetery area, *circ.* 7.00 m. below the surface. (P.31.16.740.)
- U.14436 Fragment of a terra-cotta figurine of a nude female, in green clay with details in black paint; only part of one buttock with lines of drapery (?); ht. 0.035 m. Royal Cemetery area, *circ.* 7.00 m. below the surface. Pl. 22. (B. 9283.)
- U.14439 Copper fish-hook, unbarbed; the shaft flattened and rolled over for attachment; square in section. L. 0.041 m. Pit F, sq. D7, level 10.00 m. Pl. 30. (L. *BM.* 123615.)
- U.14440 Copper arrow-head, leaf-shaped with flat hammered blade and square-section tang, l. 0.18 m., width 0.04 m. Pit F, sq. D6, level 10.00 m. Pl. 30. (P.31.17.225.)
- U.14446 Rosette of black steatite, worked on both sides, the petals engraved as if for inlay, the corolla inlaid with a shell disk. Diam. 0.02 m. Pit F, sq. E6, level 10.00 m. Pl. 44.
- U.14447 Copper fish-hook, barbed, the haft broken and missing; l. 0.021 m. Pit F, sq. D7, level 9.70 m. Pl. 30. (L. *BM.* 123616.)
- U.14448 Clay bead, part of, long tubular with ridges at the end; orig. l. perhaps 0.08 m. Pit F, level 10.00 m. (L. *BM.* 123767.)

- U.14449 Clay vase-lid; a saucer of drab clay with a large hole in the middle and two smaller holes close together high up on one side; it is a clay version of a fairly common stone type, *v.* Fig. 12,b, ht. 0.04 m., diam. 0.105 m. Pit F, level *circ.* 11.00m. (L. *BM.* 123765.)
- U.14451 Brick, made of white lime cement (gypsum burnt and slaked) rectangular and flat, 0.21 m. x 0.095 m. x 0.06 m. It was made in a wooden mould set on a piece of matting of which the impression remains on the under side; in technique it is identical with the cement bricks from Mereijib, *cf.* U.14452-3. Pit F, sq. C6, level 9.80m. (P.31.16.347 and 348.)
- U.14452-3 Bricks made of cement, rectangular and flat, 0.25 m. x 0.125 m. x 0.10 m. *Cf.* U.14451. From Mereijib. (L. *BM.* 123762.)
- U.14454 Clay vase, fragments of, light red clay, decorated by two bands of deep chocolate-coloured paint joined by wavy streamers; only the upper part, rim diam. 0.14 m. Pit F, sq. C6, level 10.20m. Fig. 9. (L. *BM.* 129081.)
- U.14455 Clay bowl, ht. 0.43 m., diam. 0.75 m., of red clay, coarse, with design roughly painted in bitumen. Pit F, sq. D8, building stratum H. Pl. 45.
- U.14459 Statuette in grey steatite, of a wild boar, carved in the round; in the top of the back is a circular hole as if for a wooden upright; on each flank is a sharply-cut groove implying that the figure was held by a stand having curved arms, probably a metal representation of reeds. Ht. 0.055 m., l. 0.12 m. *v.* p. 31. Pit F, sq. C7, level 9.00 m. Pl. 37. (B.9015.)
- U.14459a Stone bowl, alabaster, Type JN.3, ht. 0.07 m., diam. 0.045 m. JNG/348.
- U.14460a Copper pin, l. 0.19 m. Pit F, sq. E7, level 9.40 m. (P.31.17.268.)
- U.14461a Copper fish-hook, unbarbed, the top of the shaft flattened for attachment; l. 0.032 m. Pit F, level 10.60 m. Pl. 30. (L. *BM.* 129086.)
- U.14462 Four copper bull's hoofs, hammered over a bitumen core, *v.* p. 38. Diam. 0.11 m. SIS 4-5. Pl. 29. (divided among the 3 museums.)
- U.14462a Clay spoon, l. 0.084 m. Pit F, sq. C6, level 9.40 m. Pl. 16. (L. *BM.* 124494.)
- U.14464 Clay spindle-whorl, greenish drab clay, conical, with roughly incised decoration. Pit F, sq. C6, level 9.40 m. Pl. 16. (P.31.16.559.)
- U.14465 Stone bowl, white calcite, miniature of Type RC.108; ht. 0.025 m. Pit Y, SIS 5. (P.31.16.394.)
- U.14466 Clay spool, l. 0.05 m., diam. 0.05 m.; Pit F, sq. C6, level 9.40 m. Pl. 16. (B.29771.)
- U.14469 Bead, double conoid, of blue-glazed frit; Pit F, sq. E7, level 9.40 m. (L. *BM.* 122851.)
- U.14476 Stamp seal, white marble, oval with convex top; crude design of animal figures. Pit F, sq. D8, level 9.80 m. Pl. 44. (L. *BM.* 122839.)
- U.14477 Pendant, bi-conoid, of rock crystal, l. 0.026 m. Pit F; sq. D4, level 9.80 m. (L. *BM.* 123620.)
- U.14478 Cylinder seal, steatite, Vol. X, No. 30. Pit F, level 10.00 m. (L. *BM.* 122837.)
- U.14479 Beads; five, of black steatite, tubular and ringed as if lathe-turned. Pit F, sq. D8, Level 9.80 m. (L. *BM.* 122773, 122775-6, 122781-2.)
- U.14480 Beads, five clay imitations of the very long tubular beads cut from the column of the conch shell; they seem to have been moulded on a string which was then pulled out, not made and subsequently pierced. Pit F, sq. D8, level 9.80 m. (L.)
- U.14481 Stone vase, grey gypsum, Type RC.106, ht. 0.054 m. Pit F, sq. D4, level 9.50 m. (P.31.16.392.)
- U.14482 Pendant of white marble, bi-conoid; l. 0.04 m. Pit F, sq. C8, level 9.80 m. Pl. 16. (B.21302.)
- U.14484 Bone pin with decorated top (point missing) l. 0.07 m. Pit F, sq. E4, level 9.50 m. Pl. 15. (L. *BM.* 123629.)
- U.14485 Pot sherd from a pot apparently of Type JN.51, of light red clay with red-painted design like writing on the shoulder. Pit F, about level 10.20 m. Fig. 9,e. (L. *BM.* 122881.)
- U.14489 Cylinder seal, steatite, Vol. X, No. 31. Pit F, sq. D6, level 8.00 m. (P.31.17.16.)
- U.14490a Beads; a necklace consisting of 4 elliptical shell plaques 0.065 m. x 0.02 m. and 14 roughly cut haematite cylinders, restrung in the original order. JNG/350. (P.31.17.135.)
- U.14491a Beads; shell, cylinders and roughly cut flat ovals. JNG/350. (L. *BM.* 122812.)
- U.14492a Beads; small natural shells, brown and white, pierced for stringing. JNG/350. (L. *BM.* 122811 and P.31.17.137-8.)
- U.14493a Stone bowl, diorite, Type JN.26, ht. 0.115 m., diam. 0.155 m. JNG/350.
- U.14494 Amulet, pink marble, crudely cut in the form of a bird (?) and pierced below for suspension; l. 0.027 m. Pit F, sq. D6, level 8.00 m. Pl. 28. (P.31.17.87.)
- U.14494a Stone bowl, basic diorite, Type JN.26, ht. 0.09 m., diam. 0.155 m. JNG/351. (B.16884.)
- U.14495 Cylinder seal, shell, Vol. X, No. 28. Pit F, sq. D5, level 8.70 m. (P.31.17.18.)
- U.14495a Stone vase, white calcite, Type JN.54; ht. 0.11 m., diam. 0.145 m. JNG/351.
- U.14496 Stone bowl, white calcite, Type JN.9; ht. 0.08 m., diam. 0.10 m. JNG/351. (B.16885.)
- U.14497 Copper fish-hook, unbarbed, the top of the shaft flattened and pierced; l. 0.06 m. Pit F, about level 9.00 m. (L. *BM.* 123619.)
- U.14497a Stone bowl, dark green basic diorite, Type JN.28; ht. 0.14 m. diam. 0.21 m. JNG/351.

- U.14498 Copper pin; the shaft round in section, one end sharply and the other slightly pointed; l. 0.18 m. Pit F, sq. C6, level 9.00 m.
- U.14498a Beads; small carnelian and lapis barrels. JNG/351. (L. *BM.* 122807 and P.31.17.105.)
- U.14499 Copper pin or spatula; a slender rod with one end flattened to a disk 0.005 m. in diam; l. 0.115 m. Pit F, sq. E4, level 9.00 m.
- U.14499a Stone bowl, basic diorite, Type JN.27; ht. 0.105 m., diam. 0.205 m. JNG/352.
- U.14500 Stone bowl, basic diorite, Type JN.10; ht. 0.05 m., diam. 0.095 m. Pit Y, loose in the soil by the JN. graves.
- U.14500a Clay cone for wall mosaic, the blunt end painted black, unusually large, l. 0.155 m., diam. 0.03 m. Pit F, sq. C6, level 9.00 m. (L. *BM.* 129085.)
- U.14902 Clay pot, upper part of; of Jamdat Nasr ware with 3-colour decoration. Pit F, level 9.00 m.
- U.14906-7 Flint hoes; Pit F, level 9.00 m.
- U.14908 Bowl of blue-glazed frit. Pit F, sq. C4, Level 9.25 m. Pl. 26. (P.31.17.11.)
- U.14909 Clay pot, of red-painted burnished ware, variant of Type JN.150; ht. to shoulder 0.17 m. Pit F, sq. D5, level 9.30 m. Pl. 26. (P.31.17.317.)
- U.14912 Flint hoe, l. 0.135 m. Pit F, Level 8.70 m. (B30667.)
- U.14914 Stone bowl, basic diorite, Type JN.5; ht. 0.05 m., diam. 0.08 m. JNG/369. (P.31.16.361.)
- U.14915 Stone bowl, white limestone, Type JN.19; ht. 0.04 m., diam. 0.11 m. Pit Z, close to the Jamdat Nasr graves, associated with fragments of bones.
- U.14920 Two flints, slightly saw-edged scrapers, set in bitumen which had fixed them to a handle of wood or bone. Pit F, sq. E7, level *circ.* 8.50 m. Pl. 13. (L. *BM.* 124495 & P.31.16.519.)
- U.14922 Copper spatula; a slender rod with one end flattened to a disk head; l. 0.085 m. Pit F, sq. E4, level 9.00 m. Pl. 30. (P.31.17.270.)
- U.14923 Copper fish-hook, unbarbed; the shaft apparently broken, l. 0.042 m. Pit F, sq. C7, level 8.50 m. (L. *BM.* 123617.)
- U.14924 Copper pin (?), bent like a fish-hook, but perhaps accidentally; sharpened at one end, the other end rounded; l. 0.10 m. Pit F, sq. E7, level 8.00 m. Pl. 30. (P.31.17.267.)
- U.14925 Stone handle of a drill (?); l. 0.065 m., diam. 0.046 m. Pit F, sq. E7, level *c.* 8.50 m. Pl. 15. (P.31.16.481.)
- U.14926 Clay sickle, broken but complete, greatest l. 0.24 m. Pit F. sq. C7, level *c.* 8.50 m.
- U.14927 Two clay objects, found together, possibly tools used by a potter. Both are curved and flat with a section in the shape of a truncated triangle, one has one end rounded, both ends of the other are square; *v.* Pl. 45. Pit F, sq. D4, level *c.* 8.30 m. (B.30661-2.)
- U.14929 Bead, of white marble, a long tube thickened in the centre like a shell bead; l. 0.08 m. Pit F, sq. E6, level *c.* 8.30 m. (L. *BM.* 124493.)
- U.14930 Clay bottle, the shape possibly phallic; in the rim are 4 holes drilled through to the side of the neck, for the attachment of a stopper. Ht. 0.055 m. Pit F, sq. D5, level 8.00 m. Pl. 44. (L. *BM.* 124491.)
- U.14931 Spindle-whorl of drab clay, one side decorated with slashes and punched dots; diam. 0.045 m. Pit F, sq. C7, level *c.* 8.50 m. Pl. 16. (L. *BM.* 124490.)
- U.14932 Flint hoe; at the pointed end there are traces of the bitumen by which it was fastened to its handle; l. 0.14 m. Pit F, sq. C6, level *c.* 8.00 m. Pl. 25. (B.30668.)
- U.14933 Clay spoon, of greenish drab ware, l. 0.118 m. Pit F, level 8.00 m. *Cf.* U.14462, Pl. 16.
- U.14933a Clay "nails"; the shaft is sometimes regularly curved, sometimes straight for most of its length and then sharply bent. L. 0.10 m. - 0.13 m. Pit F, level 8.00 m.
- U.14938 Clay tool; a potter's smoother (?); crescent-shaped and flat, l. 0.094 m., thickness 0.005 m. also a second, l. 0.09 m. Pit F, sq. C6, level *c.* 7.80 m. Pl. 45. (L. *BM.* 124480.) (P.31.16.709.)
- U.14939 Clay tool, possibly a potter's burnisher; the blade is triangular in section, the wider or top side slightly concave - it looks like a clay copy of a bone original. L. 0.12 m. Pit F, sq. E7-8, level *c.* 7.90 m. Pl. 45. (P.31.16.710.)
- U.14940 Bead, a ball bead of amazonite, diam. 0.009 m. Pit F, sq. C7, level 7.40 m. (P.31.17.81.)
- U.14941 Two clay spools, (A) ht. 0.045 m., diam. 0.04 m. (B) ht. 0.045 m., diam. 0.042 m. Pit F, sq. E7, level *c.* 7.80 m. *Cf.* U.14466, Pl. 16.
- U.14942 Stone tool, obsidian, triangular, roughly chipped. Pit F, level 8.00 m. Pl. 13, (P.31.16.516.)
- U.14943 Beads, glazed frit, of various shapes, collected from the stratum Pit F, level 8.30 m.-8.00 m. (L. *BM.* 122808.)
- U.14944 Amulet, of pink limestone, in the form of a phallus; l. 0.006 m. Pit F, level 8.40 m. Pl. 28. (L. *BM.* 122852.)
- U.14946 Spindle-whorl, of dark grey clay, decorated with stamped dots radiating from the centre; diam. 0.032 m. Pit F, level 8.00 m. Pl. 16. (L. *BM.* 122845.)
- U.14948 Two clay objects of uncertain use, pear-shaped with a small cap distinguished by a groove; hts. 0.028 m. and 0.021 m. Pit F, sq. C5, level 8.00 m. - 7.60 m. Pl. 16. (L. *BM.* 124488-89.)

- U.14952 Copper pin, straight, both ends pointed, l. 0.16m. Pit F, sq. D7, level c. 7.80m.
- U.14954 Clay object, of uncertain use; l. 0.037m. Pit F, level c. 7.80m. Pl. 16. (P.31.16.778.)
- U.17955 Clay jar-stopper (?), of light drab ware; flattened hemispherical with a large hole through the centre and 4 small holes in two sets of two each, placed close together on one side. Pit F, sq. E7, level c. 7.50m.
- U.14958 Zoöomorphic vase in light red clay, fragment of; the vase was in the form of a bird, of which only the back with part of the wings is preserved; the mouth of the vessel rose from the top of the bird's back. Pit F, level 7.80m. Pl. 44. (L.BM.124482.)
- U.14962 Cylinder seal, shell, l. 0.03m., diam. 0.014m.; design, a palm-branch and a running gazelle, above which an eye. Pit F, sq. D4, level 9.00m. (L.BM.122832.)
- U.14965 Beads; small rings of white shell. Pit F, sq. D4, level 7.50m. (P.31.17.100.)
- U.14968 Celt, of coarse black stone, polished; l. 0.08m. Pit F, level 7.50m. (P.31.16.474.)
- U.14969 Copper fish-hook, unbarbed, the shaft flattened at the top for attachment; on the shaft are visible traces of the string binding. L. 0.19m. Pit F, sq. E7, level 7.60m. Pl. 30. (L.BM.123618.)
- U.14970 Stud, shell, l. 0.023m. Pit F, level 8.00m. Pl. 15. (L.)
- U.14971 Stone vase, white calcite, Type RC.111; ht. 0.18m., diam. 0.10m. PFG/B.
- U.14973 Beads; very small shell rings. PFG/E. (P.31.17.71.)
- U.14974 Mace-head, pear-shaped, of very dark green pebble; ht. 0.04m., diam. 0.045m. PFG/E. (L.BM.124477.)
- U.14975 Stone bowl, white limestone, Type RC.28; ht. 0.047m., diam. 0.18m. PFG/E. (P.31.16.422.)
- U.14979 Clay figurine of a sheep (?); ht. 0.065m. Pit F, sq. C4, level 6.00m. Pl. 24. (L.BM.124483.)
- U.14980 Copper spear-head, pear-shaped with broad tang, l. 0.115m. Pit F, sq. C6, level 8.50m. Pl. 30. (B.30656.)
- U.14982 Clay object of uncertain use; a flat disk with 3 circles cut out from its rim; diam. 0.08m. Pit F, sq. C5, level 6.80m. Pl. 16. (L.BM.124497.)
- U.14983 Stud, long-shanked, of white obsidian, l. 0.034m., Pit F, sq. C4, level 6.80m. Pl. 15. (P.31.16.512.)
- U.14985 Clay model of an axe, double-edged, with socket-hole through the thickness of the clay; imperfect; l. 0.10m. Pit F, level 6.50m. Pl. 16. (P.31.16.588.)
- U.14987 Fragments of a clay vase, painted, al'Ubad ware. PFG/XX.
- U.14988 Clay vase, Type aU.47, painted. PFG/XX, q.v. Pl. 19. (P.)
- U.14990 Stone axe-head, black stone, polished; l. 0.09m. PFG/F. Pl. 14. (B.30665.)
- U.14992 Copper spear-head, l. 0.30m., of pure copper. PFG/G. Pl. 30. (P.31.17.233.)
- U.14993 Clay model of an axe, hollow-socketted with pick point on one side, the other side evidently of an axe type but broken. Present l. 0.135m. Pit F, level 6.00m. Pl. 16. (L.BM.124492.)
- U.14994 Clay figurine, crudely hand-modelled, of a humped bull; in plain reddish-drab clay; ht. 0.035m. Pit F, level 6.00m. Pl. 24. (P.31.16.749.)
- U.14995 Clay figurine, crudely hand-modelled, of a humped bull; in green clay with details in black paint. Ht. 0.055m. Pit F, level 6.50m. Pl. 23. (B.30914.)
- U.14996 Clay figurine, fragment of; crudely hand-modelled; fore-part of a bull (?) in drab clay with details in black paint. Ht. 0.08m. Pit F, level 6.00m. (L.)
- U.15101 Stone vase, grey calcite, Type JN.54, ht. 0.115m., diam. 0.15m. JNG/353.
- U.15105 Conch shell cut open to serve as a lamp. JNG/353. (P.31.16.536.)
- U.15106 Beads; lapis and carnelian rings and a few of shell, all very small. JNG/353. (B.30689.)
- U.15108 Beads; 4 shell flat ovals, 0.085m. x 0.025m. JNG/353. (L.BM.122814.)
- U.15109 Stone vase, translucent white calcite, Type JN.54, ht. 0.13m., diam. 0.155m. JNG/355.
- U.15110 Stone bowl, white calcite, Type JN.10, ht. 0.12m., diam. 0.175m. JNG/355.
- U.15111 Stone bowl, white limestone, fragmentary. JNG/355.
- U.15112 Stone bowl, grey calcite, Type JN.12, ht. 0.06m., diam. 0.125m. JNG/356.
- U.15113 Stone bowl, basic diorite, Type JN.26, ht. 0.04m., diam. 0.095m. JNG/356. (P.31.16.367.)
- U.15114 Stone bowl, basic diorite, Type JN.13, ht. 0.03m., diam. 0.095m. JNG/356. (P.31.16.364.)
- U.15115 Stone bowl, diorite, Type JN.13, ht. 0.04m., diam. 0.14m. JNG/356.
- U.15116 Stone bowl, alabaster, Type JN.14, ht. 0.075m., diam. 0.11m. JNG/356.
- U.15117 Stone bowl, white alabaster, Type JN.13, ht. 0.07m., diam. 0.09m. JNG/356.
- U.15118 Stone bowl, white alabaster, Type JN.17, ht. 0.045m., diam. 0.115m. JNG/356.
- U.15119 Beads; lapis and carnelian cylinders. JNG/359. (L.BM.122794.)
- U.15120 Stone bowl, diorite, Type JN.26, ht. 0.09m., diam. 0.155m. JNG/351. (P.31.16.377.)
- U.15121 Stone tumbler, diorite, Type JN.36, ht. 0.175m., diam. 0.125m. JNG/357. (P.31.16.374.)
- U.15122 Stone bowl, basic diorite, Type JN.17, ht. 0.06m., diam. 0.135m., JNG/354. (L.BM.123756.)
- U.15124 Stone bowl, basic diorite, Type JN.16, ht. 0.04m., diam. 0.075m. JNG/349. (P.31.16.363.)
- U.15125 Stone bowl, white limestone, Type JN.55, ht. 0.21m., diam. 0.30m. JNG/349.

- U.15126 Stone bowl, basic diorite, Type JN.10, ht. 0.105 m., diam. 0.185 m. JNG/349. (P.31.16.375.)
- U.15127 Stone tumbler, white calcite, Type JN.37, ht. 0.13 m., diam. 0.12 m. JNG/360. (B.16886.)
- U.15133 Stone tumbler, basic diorite, Type JN.34, ht. 0.14 m., diam. 0.105 m. JNG/359. (P.31.16.372.)
- U.15134 Stone bowl, white calcite, Type JN.28, ht. 0.125 m., diam. 0.21 m., JNG/358.
- U.15135 Stone bowl, white calcite, Type JN.36, JNG/358. (P.31.16.463.)
- U.15138 Clay tumbler, Type JN.27, ht. 0.13 m., diam. 0.135 m.; the upper part is decorated with incised lines and near the rim are two small bosses like breasts set close together. Pit Y, near the JN graves. (L.BM.124478.)
- U.15140 Stone bowl, diorite, Type JN.38, ht. 0.125 m., diam. 0.135 m. Pit Y, near the JN graves. (P.31.16.373.)
- U.15160 Stone bowl, basic diorite, Type JN.12, ht. 0.04 m., diam. 0.09 m. JNG/365.
- U.15164 Copper mirror (?), a disk of thin metal with a short flat tang, diam. 0.14 m. JNG/363.
- U.15165 Stone bowl, basic diorite, Type JN.16, ht. 0.025 m., diam. 0.09 m. JNG/363.
- U.15169 Stone bowl, dark steatite, Type JN.21, ht. 0.035 m., diam. 0.125 m.; the rim decorated with a double chevron incised. JNG/367. (P.31.16.360.)
- U.15323 Stamp seal, black steatite, square flat type with oval handle laterally pierced; 0.021 m. sq. The face has a linear design, much worn. Pit F, level 5.50 m. Pl. 28. (L.BM.122838.)
- U.15324 Clay figurine, crudely hand-modelled, of a sheep (?); ht. 0.03 m. Pit F, level 5.80 m. Pl. 24. (P.31.16.973.)
- U.15325 Clay figurine crudely hand-modelled, of a pig (?); ht. 0.04 m. Pit F, level 5.50 m. Pl. 24. (L.)
- U.15326 Clay figurine, crudely hand-modelled, of a sheep (?); ht. 0.04 m. Pit F, level 5.50 m. Pl. 24. (P.31.16.947.)
- U.15327 Clay sling-bolts, pear-shaped, l. c. 0.04 m. Pit F, level 6.00 m.-5.50 m. (L.BM.124496 and P.31.16.584.)
- U.15328 Clay object, use uncertain, ht. 0.05 m., diam. 0.023 m. Pit F, level 5.80 m. Pl. 45. (L.)
- U.15329 Clay studs, long-shanked, like those made of obsidian, *cf.* Pl. 15, U.14983. Pit F, level 6.50 m.-5.50 m.
- U.15331 Terra-cotta figurine, fragment of, a nude female; hand-modelled in reddish clay with details in black paint. Ht. 0.036 m. Pit F, level 5.70 m. Pl. 22. (L.BM.122875.)
- U.15332 Bitumen object, perhaps a staff-head; l. 0.074 m. Pit F, level 6.00 m. Pl. 15. (P.31.16.551.)
- U.15333 Stone arrow-head, chalcedony, barbed, l. 0.036 m. Pit F, sq. C4, level 6.70 m. (L.BM.122868.)
- U.15334 Mud figurine, fragment of; human figure, the head missing, finished off at the hips; ht. 0.045 m. Pit F, sq. D4, level 6.50 m. Pl. 23. (L.)
- U.15335 Clay cup, Type aU.25, painted. PFG/K, *q. v.* Pl. 18. (B.8557.)
- U.15346 Clay object, apparently a rubber; irregularly convex above, the under surface smooth and striated by use. L. 0.185 m., width 0.08 m. Pit F, level 6.50 m. (P.31.16.344.)
- U.15347 Figurine of unbaked clay, crudely hand-modelled, of a humped bull; ht. 0.04 m. Pit F, level 6.00 m. Pl. 24. (P.31.16.748.)
- U.15348 Figurines of unbaked clay, crudely hand-modelled, of cattle; four in all, av. ht. 0.04 m. Pit F, level c. 6.00 m. (L.BM.124484; and P.31.16.946, 948.)
- U.15349 Clay figurine, fragment of, of a nude female, hand-modelled, the body above the waist and the feet missing, in greenish clay; round the waist a belt in black paint. Ht. 0.07 m. Pit F, level 6.00 m. Pl. 22. (P.31.16.738.)
- U.15350 Clay cup, Type aU.25, painted. PFG/M, *q. v.* (L.)
- U.15351 Clay cup, Type aU.25, painted. PFG/N, *q. v.*
- U.15352 Clay cup, Type aU.25, painted. PFG/N, *q. v.*
- U.15353 Mace-head, white marble, pear-shaped but rather squat; ht. 0.035 m., diam. 0.045 m. Found beside one of the skulls lying together in confusion in Pit F, sq. E7, level 5.50 m. (P.31.16.479.)
- U.15354 Clay figurines, fragments of, hand-modelled in green clay with details in black paint; (A) striped body of a tiger (?), head and legs missing; (B) spotted animal, only the hindquarters preserved; (C) forequarters of buffalo; (D) fore part of pig. Pit F, level 5.50 m. Pl. 22. (P.31.16.742, 745, 998, and L.)
- U.15355 Figurine of unbaked clay, peculiarly primitive human figure, ht. 0.073 m. Pit F, level 5.50 m. Pl. 22. (L.)
- U.15356 Clay figurines, fragments of, from similar but not the same figures of nude females hand-modelled in green clay with details in black paint; (A) trunk only, from neck to waist, (B) from waist to below the knees. Pit F, sq. E7, level 5.50 m. Pls. 20, 22. (P.31.16.735, 737.)
- U.15357 Beads; minute shell rings, a ring of amazonite and a flattened oval of grey steatite with engraved lines; PFG/L. Pl. 28. (L.BM.122850.)
- U.15358 Figurine of unbaked clay; human figure, the head missing. Ht. 0.064 m. Pit F, level 5.50 m. Pl. 22. (L.BM.124485.)
- U.15362 Clay figurine of a flying bird; hand-modelled in greenish drab clay with details in black paint;

- ht. 0.04 m. There is a hole through the body prolonged below by a tubular socket as if to mount the bird on a staff. Pit F, sq. E4, level 6.00 m. Pl. 21. (P.31.16.741.)
- U.15363 Clay bowl, Type aU.20, miniature, ht. 0.035 m., diam. 0.075 m., of drab clay with decoration in black paint. Pit F, level 5.50 m. (L.BM.122901.)
- U.15366 Clay platter, Type aU.7, painted. PFG/N, *q.v.* (L. BM. 122906.)
- U.15367 Clay vase, Type aU.32, diam. 0.34 m., of greenish drab ware with black bands below shoulder and dependent drops. Pit F, sq. E7, level 4.80 m.
- U.15368 Beads; very small shell rings. PFG/M. (P.31.17.72.)
- U.15369 Beads; shell rings; originally strung in four ranks. PFG/H. (L. BM. 122813, 122821-7; and P.31.17.37-9, 41-4.)
- U.15370 Beads, two, of amazonite, one roughly chipped to a ring, one a thick polished ring. Pit F, level 5.00 m. (P.31.17.82.)
- U.15371 Clay bowl, Type aU.7, greenish drab clay with band of black paint round the rim; the interior deeply combed probably for the crushing of grain; much distorted in firing. Ht. 0.09 m., diam. 0.23 m. Pit F, sq. D6, level 4.00 m. Pl. 17. (B.8585.)
- U.15372 Clay cup, Type aU.24, with design in black paint; incomplete. Pit F, sq. C7, in a small pit dug down at level 3.50 m.-3.00 m. and filled with ashes. Pl. 18. (B.8555.)
- U.15373 Clay cup, Type aU.25, with design in black paint; incomplete. Pit F, sq. C7, in a small pit dug down at level 3.50 m.-3.00 m. and filled with ashes. (L. BM. 122900.)
- U.15374 Clay cup, Type aU.23, painted. PFG/N, *q.v.*
- U.15375 Clay vase, Type aU.39, painted; the base is curiously heavy and has been trimmed with a knife after potting. PFG/O, *q.v.* (B.8562.)
- U.15376 Clay figurine, the head missing, modelled in drab clay with details in black paint. A nude female figure suckling an infant; dots on the right shoulder and stripes on the left may be tattoo marks; she wears necklace and bracelets and girdle rendered in paint. Ht. 0.135 m. PFG/O. Pl. 20. (L. BM. 122873.)
- U.15377 Clay vase, Type aU.46, with design in black paint; ht. 0.25 m. Loose in the soil, Pit F, level 3.50 m. Pl. 17. (B.8589.)
- U.15378 Beads; very small rings of dark steatite and shell worn at the wrist in parallel strings perhaps sewn to cloth. PFG/T. (L. BM. 122783-85.)
- U.15379 Terra-cotta figurine of a nude female with her hands against her waist. She wears a high coiffure or head-dress originally covered with bitumen; traces remain of black paint in the eyes and of red paint on the cheeks; ht. 0.14 m. PFG/T. Found broken in two pieces, lying by the hands of the body. Pl. 20. (P.31.16.734.)
- U.15380 Terra-cotta figurine of a nude female with her hands against her waist. On the high head-dress are remains of the bitumen which covered it. The face is damaged and parts of it have flaked away, and the left lower arm is missing. Ht. 0.15 m. PFG/Q. Found in fragments and restored. Pl. 20. (L. BM. 122872.)
- U.15381 Beads, very small shell rings, found on the arm of a body in an otherwise empty (and unrecorded) grave; Pit F, sq. E6, level 5.00 m.-4.60 m. (L. BM. 122719.) (B.9608.)
- U.15382 Clay cup, Type aU.23, painted. PFG/P, *q.v.* Pl. 18. (B.8559.)
- U.15383 Clay cup, Type aU.23, painted. PFG/P, *q.v.* Pl. 18. (B.8559.)
- U.15384 Clay cup, Type aU.25, painted. PFG/Z, *q.v.* Pl. 18. (B.8561.)
- U.15385 Terra-cotta figurine of a nude female standing and with her hands resting against her waist; the bitumen covering of her high head-dress is preserved. Ht. 0.16 m. PFG/T. Pl. 20. (P.31.16.733.)
- U.15386 Clay cup, Type aU.23, painted. PFG/U, *q.v.* (L. BM. 122898.)
- U.15387 Clay cup, Type aU.26, painted. PFG/Z, *q.v.* Pl. 19. (P.31.17.302.)
- U.15389 Clay cup, Type aU.25, painted. PFG/Z, *q.v.*
- U.15390 Clay cup, Type aU.23, painted. PFG/X, *q.v.* Pl. 19. (P.31.17.300.)
- U.15391 Clay cup, Type aU.25, painted. PFG/U, *q.v.* (B.8596.)
- U.15392 Clay cup, Type aU.25, painted. PFG/U, *q.v.* L. BM. 122899.)
- U.15393 Clay cup, Type aU.25, painted. PFG/Y, *q.v.*
- U.15394 Clay vase, Type aU.48, painted. PFG/R, *q.v.* Pl. 17. (L. BM. 122885.)
- U.15395 Clay cup, Type aU.25, painted. PFG/U, *q.v.* Pl. 19. (P.31.17.311.)
- U.15396 Clay bowl, Type aU.3a, painted. PFG/KK, *q.v.* Pl. 17. (B.8587.)
- U.15397 Clay platter, Type aU.4, painted. PFG/Z, *q.v.* (P.31.17.289.)
- U.15398 Clay figurine, head of; unusual type with high skull, full face, horizontal slit eyes and small mouth; the face painted bright red with traces of black bands on the high head-dress. Ht. 0.04 m. Pit F, in a layer of ashes at level c. 2.00 m. Pl. 22. (P.31.16.736.)
- U.15399 Terra-cotta figurine, fragment of; nude female figure modelled in pinkish drab clay with details in black paint; the head and body to the waist preserved; ht. 0.043 m. Loose in the soil, Pit F, level 2.00 m. Pl. 22. (B.25131.)

- U.15400 Clay bowl, Type aU.3, ht. 0.075 m., diam. 0.20 m., of brown clay fired in a smother-kiln to black on the surface, very lightly baked and flaky. PFG/Z.
- U.15414 Stone bowl, white limestone, Type JN.18, ht. 0.045 m., diam. 0.145 m. Pit Y, by the JN graves. (P.31.16.421.)
- U.15501 Clay tumbler, Type aU.16, painted. PFG/R, *q.v.* Pl. 18. (B.8579.)
- U.15502 Clay vase, Type aU.44, painted. PFG/GG, *q.v.* Pl. 17. (L. *BM.* 122883.)
- U.15503 Clay vase, Type aU.38, painted. PFG/GG, *q.v.* (P.31.17.298.)
- U.15504 Clay cup, Type aU.11, painted; red body with creamy slip and design in black. Ht. 0.055 m., diam. 0.045 m. Pit F, level 2.00 m., in the lowest ash stratum. Pl. 18. (B.8563.)
- U.15505 Clay cup, Type aU.25, painted. PFG/AA, *q.v.* Pl. 17. (L. *BM.* 122896.)
- U.15506 Terra-cotta figurine of a nude woman holding an infant; modelled in very light creamy drab clay with details painted in black; the high head-dress is covered with a wig (?) of bitumen; the infant's head is painted black; pellets of clay added on the shoulders may represent tattoo marks. Ht. 0.14 m. Restored from fragments, the feet missing. PFG/AA*bis.* Pl. 20. (B.8564.)
- U.15507 Terra-cotta figurine of a nude female standing with her hands resting against her waist; modelled in very light drab clay with a bitumen covering to the high head-dress. Ht. 0.15 m. Restored from fragments. PFG/JJ. Pl. 20. (B.8574.)
- U.15508 Clay cup, Type aU.23, painted. PFG/MM, *q.v.* Pl. 19. (P.31.17.306.)
- U.15509 Clay cup, Type aU.23, painted; pinkish drab clay with decoration in brown; fragmentary. Pit F, loose in soil at c. 2.00 m. level. (L. *BM.* 129079.)
- U.15510 Clay cup, Type aU.23, painted PFG/CC, *q.v.* (L. *BM.* 122899.)
- U.15511 Stone palette, a disk of reddish-brown pebble; in the centre a patch of red ground powder of exactly the shade used to paint the figurine U.15398. Diam. 0.105 m. Pit F, level 2.00 m. (P.31.16.486.)
- U.15513 Clay vase, Type aU.31, painted. PFG/KK, *q.v.* (P.31.17.367.)
- U.15514 Clay "smoother," of greenish drab clay, l. 0.11 m., width 0.053 m., thinned at the edges; shape as U.14927. Pit F, level 2.00 m. (L. *BM.* 124479.)
- U.15516 Terra-cotta figurine, fragment of; the head and body to the waist (arms missing) of a nude female figure. There was probably a high head-dress, but it is broken away. The facial treatment is unusual. Ht. 0.045 m. PFG/QQ. Pl. 22. (B.25132.)
- U.15517 Clay platter, Type aU.4, painted. PFG/MM, *q.v.*
- U.15518 Clay platter, Type aU.4, painted. PFG/NN, *q.v.* Pl. 19. (P.31.17.290.)
- U.15520 Bone stylus or pin, with rounded tip and flat arrow-shaped head, l. 0.13 m. PFG/PP. Pl. 15. (L. *BM.* 123630.)
- U.15521 Clay platter, Type aU.4, painted. PFG/Q, *q.v.* (L. *BM.* 122909.)
- U.15523 Clay cup, Type aU.23, painted. PFG/Q, *q.v.*
- U.15525 Clay vase, Type aU.30, painted. PFG/UU, *q.v.* (L. *BM.* 122892.)
- U.15526 Clay cup, Type aU.23, painted. PFG/HH, *q.v.* Pl. 19. (P.31.17.304.)
- U.15527 Clay cup, Type aU.25; light drab clay with design in black paint; ht. 0.08 m., diam. 0.11 m. Pit F, Sq. E6, level 3.00 m. Pl. 18. (B.8560.)
- U.15528 Clay bowl, Type aU.22, painted. PFG/SS, *q.v.*
- U.15529 Clay jug, Type aU.50, painted PFG/QQ, *q.v.* (P.)
- U.15531 Clay cup, Type aU.23, painted. PFG/O, *q.v.* (B.8556.)
- U.15532 Clay cup, Type aU.26, painted. PFG/V, *q.v.* Pl. 18. (B.8554.)
- U.15533 Clay bowl, Type aU. 3a, painted. PFG/V, *q.v.* Pl. 17. (L. *BM.* 122895.)
- U.15534 Clay cup, Type aU.25, painted. PFG/F, *q.v.* (L. *BM.* 124473.)
- U.15535 Clay bowl, Type aU.31, painted, PFG/P, *q.v.* (P.31.17.313.)
- U.15536 Clay cup, Type aU.25, painted. PFG/T, *q.v.* (B.30911.)
- U.15537 Clay cup, Type aU.25, painted. PFG/X, *q.v.* Pl. 18. (P.31.17.305.)
- U.15538 Clay platter, Type aU.8, painted. PFG/T, *q.v.*
- U.15539 Clay cup, Type aU.23, painted. PFG/T, *q.v.* Pl. 18. (P.31.17.308.)
- U.15540 Clay cup, Type aU. 26, painted. PFG/Z, *q.v.* (L. *BM.* 129080.)
- U.15541 Clay cup, Type aU.25, painted. PFG/Z, *q.v.* (P.31.17.330.)
- U.15543 Clay cup, Type aU.25, painted. PFG/JJ, *q.v.* (L. *BM.* 122891.)
- U.15544 Clay vase, Type aU.31, painted. PFG/JJ, *q.v.*
- U.15545 Clay cup, Type aU.25, painted. PFG/JJ, *q.v.* Pl. 18, (P.31.17.307.)
- U.15546 Clay bowl, Type aU.6, painted. PFG/LL, *q.v.* Pl. 17. (L. *BM.* 122905.)
- U.15547 Clay vase, Type aU.44, painted; ht. 0.14 m.; the spout missing. Found near PFG/KK.
- U.15548 Clay bowl, Type aU.7, painted. PFG/CC, *q.v.* (P.31.17.295.)
- U.15549 Clay platter, Type aU.7, painted. PFG/JJ, *q.v.* Pl. 19. (P.31.17.287.)
- U.15550 Clay cup, Type aU.25, painted. PFG/W, *q.v.* (L. *BM.* 124471.)

- U.15551 Clay cup, Type aU.25, painted. PFG/W, *q.v.* (L. *BM.*124472.)
- U.15552 Clay platter, Type aU.4, painted. PFG/OO, *q.v.* Pl. 19. (P.31.17.288.)
- U.15553 Clay bowl, Type aU.8, painted. PFG/CC, *q.v.* (B.30912.)
- U.15554 Clay bowl, Type aU.3a, painted. PFG/PP, *q.v.* (P.31.17.292.)
- U.15555 Clay vase, Type aU.33, painted. PFG/PP, *q.v.* (B.8581.)
- U.15557 Clay bowl, Type aU.3a, painted. PFG/QQ, *q.v.* (B.30913.)
- U.15558 Clay bowl, Type aU.8, painted. PFG/AA, *q.v.* Pl. 17. (B.8586.)
- U.15560 Clay cup, Type aU.25, painted. PFG/R, *q.v.* (L. *BM.*124475.)
- U.15561 Clay cup, Type aU.23, painted. PFG/R, *q.v.* (L. *BM.*124474.)
- U.15562 Clay vase, Type aU.34, painted. PFG/FF, *q.v.*
- U.15565 Clay bowl, Type aU.3a, painted. PFG/UU, *q.v.* Pl. 17. (L. *BM.*122893.)
- U.15566 Terra-cotta figurine, fragment of; nude female figure with hands on breasts, modelled in drab clay; head and legs missing. Ht. 0.034 m. Pit F, Level 2.00m. the lowest occupation stratum. Pl. 22. (L. *BM.*124486.)
- U.15567 Clay cup, Type aU.25, painted. PFG/S, *q.v.* (B.8595.)
- U.15568 Clay cup, Type aU.25, painted. PFG/S, *q.v.* Pl. 18. (P.31.17.309.)
- U.15569 Clay cup, Type aU.23, painted. PFG/V, *q.v.* Pl. 18. (B.8580.)
- U.15570 Clay cup, Type aU.23, painted. PFG/MM, *q.v.*
- U.15571 Clay cup, Type aU.23, painted. PFG/MM, *q.v.* Pl. 19. (P.31.17.301.)
- U.15573 Clay bowl, Type aU.21, painted. PFG/MM, *q.v.* (L. *BM.*124529.)
- U.15574 Clay cup, Type aU.23, painted. PFG/CC, *q.v.*
- U.15575 Clay platter, Type aU.4, painted. PFG/VV, *q.v.* (B.8592.)
- U.15576 Clay platter, Type aU.3a, painted. PFG/JJ, *q.v.* (P.31.17.285.)
- U.15577 Clay cup, Type aU.23, painted. PFG/KK, *q.v.* Pl. 17, (L. *BM.*122890.)
- U.15579 Clay cup, Type aU.23, painted. PFG/RR, *q.v.*
- U.15580 Clay platter, Type aU.4, painted. PFG/RR, *q.v.* (L. *BM.*)
- U.15581 Clay cup, Type aU.25, painted. PFG/JJ, *q.v.*
- U.15583 Celt, polished, of green stone; 0.033m. x 0.031m. Pit F, level 1.50m.
- U.15584 Celt, polished, the edge flat but not sharpened. Ht. 0.06m., width 0.046m. Pit F, level 1.50m. Pl. 14. (B.30671.)
- U.15585 Stone burnisher; a long pebble, round in section, each end worn smooth by rubbing with the stone at an angle of 45 degrees with the object; l. 0.12m. Pit F, level 1.20m.
- U.15586 Stone pestle or pounder, granite, oviform, l. 0.15m., diam. 0.05m. Pit F, level 1.20m. (L. *BM.*123592.)
- U.15587 Stone grinder of mottled grey steatite, ht. 0.09m. Pit F, level 1.20m. Pl. 13. (P.31.16.478.)
- U.15588 Clay cup, Type aU.23, painted. PFG/TT, *q.v.* Pl. 18. (P.31.17.310.)
- U.15589 Clay cup, Type aU.23, painted. PFG/TT, *q.v.* (L. *BM.*122904.)
- U.15591 Clay platter, Type aU.4, painted. PFG/MM, *q.v.*
- U.15592 Clay cup, Type aU.23, painted. PFG/SS, *q.v.* Pl. 17. (P.31.17.355.)
- U.15593 Clay platter, Type aU.3, painted. PFG/SS, *q.v.* Pl. 19. (P.31.17.291.)
- U.15594 Clay cup, Type aU.25, painted; fragmentary. Pit F, Sq. D6, level 4.50m. (L. *BM.*122886.)
- U.15595 Sherds from a clay cup, with designs of gazelles feeding, and what may be nets in front of them. Pit F, level 1.20m. Pl. 18. (B.30909.)
- U.15596 Clay vase, Type aU.30, ht. 0.06m., rim diam. 0.05m., PFG/VV.
- U.15600 Clay platter, Type aU.8, painted; green clay with plain black border; incomplete. Pit F, near the graves.
- U.15601 Clay bowl, Type aU.3a, painted. PFG/FF, *q.v.* Pl. 17. (B.8593.)
- U.15602 Clay vase, Type aU.43, painted. PFG/O, *q.v.* Pl. 19.
- U.15603 Terra-cotta figurine, fragment of; nude female figure with hands below breasts, head and body below waist missing. Modelled in drab clay with traces of black paint for details. Ht. 0.04m. Pit F, level c. 2.00m. Pl. 22. (L. *BM.*)
- U.15604 Clay cup, Type aU.23, painted; greenish drab clay with black paint; incomplete. Pit F, loose in the soil in the graves stratum. (B.30910.)
- U.15605 Clay cup, Type aU.25, painted. PFG/V, *q.v.* Pl. 18. (B.8582.)
- U.15606 Bead, dark steatite, flattened date-shaped with linear pattern engraved on one side; much worn. L. 0.023m. Pit F, low down in the graves stratum. Pl. 28. (B.30926.)
- U.15607 Clay cup, Type aU.24, painted; drab clay with decoration in black paint; incomplete. Pit F, level 1.00m. Pl. 19. (P.31.17.303.)
- U.15608 Clay bowl, Type aU.19, painted. PFG/BB, *q.v.* (P.31.17.316.)
- U.15612 Terra-cotta figurine, fragment of; fore part of a buffalo modelled in greenish drab clay with details in black paint; ht. 0.038m. Pit F, level 3.00m. Pls. 21, 23. (L. *BM.*122876.)
- U.15615 Clay vase, Type aU.43, painted. PFG/JJ, *q.v.*





- U.15618 Clay pot, Type aU.55, painted. PFG/Q, *q.v.*
- U.15620 Clay vase, fragments of; a large vessel of creamy drab clay with spiral design in black paint. PFG/R.
- U.15621 Clay cup, Type aU.25, painted. PFG/R, *q.v.* (L. *BM.* 124476.)
- U.15624 Clay vase, Type aU.45, painted. PFG/UU, *q.v.* Pl. 18. (L. *BM.* 122884.)
- U.15625 Clay vase, Type aU.47, painted. PFG/TT, *q.v.*
- U.15626 Clay vase, Type aU.43, painted. PFG/V, *q.v.*
- U.15632 Clay bowl, Type aU.4, painted. PFG/QQ, *q.v.*
- U.15757 Beads; minute carnelian rings. JNG/355. (L. *BM.* 122806.)
- U.15773 Stone vase, alabaster, Type JN.54, ht. 0.13 m., diam. 0.15 m. From a partially excavated grave. (B.8626.)
- U.15796 Amulet; terra-cotta figure of a tortoise with incised linear pattern; l. 0.032 m. Pit K, at a depth of 13.50 m. Pl. 27. (P.31.17.91.)
- U.16111 Terra-cotta animal figurine, fragment of, the head missing; modelled in greenish drab clay with details in black paint. L. 0.05 m. Surface find. Pl. 23. (L. *BM.* 124508.)
- U.16130 Ear-stud, dark green jasper, diam. 0.021 m., ht. 0.01 m. Royal Cemetery area, upper soil. (P.31.43.199.)
- U.16181 Stamp seal of Indus Valley type; Vol. X, No. 624. Surface find. (L. *BM.* 122945.)
- U.16220 Cylinder seal, shell, of Indus Valley type; Vol. X, No. 632. In the filling of the Dungi mausoleum. (L. *BM.* 122947.)
- U.16221 Clay model adze. L. 0.108 m., ht. 0.045 m. High in the filling of a room in the Temenos wall. Pl. 16. (L. *BM.* 123538.)
- U.16226 Stone arrow-head, broad leaf-shaped, roughly chipped from grey granite; l. 0.037 m. Found in the filling below the Temenos wall on the site of the tomb of Dungi. Pl. 13. (P.31.43.296.)
- U.16245 Engraved shell; fragment of tridachnus shell decorated with the head of a monster, apparently winged; 0.034 m. x 0.024 m. Surface. Pl. 38. (P.31.43.189.)
- U.16397 Button seal of glazed pottery bleached white; Indus Valley type, Vol. X, No. 625. Surface find. (P.31.43.74.)
- U.16400 Head of a bird, carved in the round in obsidian, socketed at the neck for fitting to a body; the lower mandible broken. L. 0.023 m. Loose in upper soil. Pl. 28. (L. *BM.* 123029.)
- U.16405 Stone borer; rather less than hemispherical, with a segment cut out from either side to give lodgement to the arms of the brace; the convex lower surface is striated by use except at the base, which perhaps means that a smaller hole was first bored to act as a guide for the larger drill-head. Diam. 0.095 m., depth 0.04 m. Surface. Pl. 13. (L. *BM.* 124498.)
- U.16408 Stamp seal, of banded black and white marble, circular with convex top, bored through its diameter. Diam. 0.038 m. Design, worked mostly with the drill-point, almost entirely perished. Found in a late house (Site AH). Pl. 44. (P.31.43.2.)
- U.16531 Mace-head, white calcite, fragment of, bearing a dedication to KA-DI by Naram-Sin. From a late house (Site AH.) (P.31.43.250.)
- U.16532 Mace-head, white calcite, fragment of, with inscription of Rimush. Diqdiqqeh. (P.31.43.251.)
- U.16603 Ear-stud, of haematite, diam. 0.029 m., ht. 0.014 m. In the filling of a late house, Site AH. Pl. 15. (B.20821.)
- U.16739 Flint arrow-heads, 5 triangular and 9 leaf-shaped; 3 barbed; also a small spoon-shaped flint. Diqdiqqeh. Pl. 13. (B.9604-5.) (L. *BM.* 124500-04, 124506-07.) (P.31.43.291-5, 297-9.)
- U.16740 Celts, 2, one of black and one of green stone. Diqdiqqeh. (B.30923-4.)
- U.16747 Stamp seal, steatite, of Indus Valley type; Vol. X, No. 628. From the upper soil over site AH. (P.31.43.75.)
- U.16981 Gold wire; square in section, twisted on itself, one end broken, the other thickened and flattened to make a head; l. 0.10 m., thickness 0.001 m. From Pit L, at level 3.25 m. in the al 'Ubaid stratum. (P.31.43.227.)
- U.17077 Engraved shell; fragment of tridachnus shell with remains of engraving; two bull's feet: 0.043 m. x 0.025 m. Diqdiqqeh. Pl. 36. (B.30678.)
- U.17114 Mace-head, limestone, pear-shaped, ht. 0.052 m., diam. 0.052 m. Pit L, level 3.25 m.
- U.17149 Clay pot, Type aU.51, ht. 0.395 m.; diam. 0.039 m. light drab clay with design in black paint; the pattern is given on Pl. 46, No. 45. Found at the very bottom of Pit K. (L. *BM.* 122184.)
- U.17187 Terra-cotta figurine, part of; head and shoulders of an animal entirely covered with small stamped circles. Ht. 0.075 m. Diqdiqqeh. (L. *BM.* 124509.)
- U.17610 Amulet, shell, in the form of a pig's head; ht. 0.022 m. Diqdiqqeh. Pl. 27. (B.9780.)
- U.17620 Terra-cotta figurine, hand modelled, of a wild boar, in greenish clay with details in black paint; l. 0.09 m. Pl. 21. (B.24394.)
- U.17625 Shell inlay, fragments of; strips 0.028 m. wide, rectangular, and of different lengths, decorated with 3 rows of "mountain" pattern; the top and bottom rows are merely outlined, with a double

- incised line which was filled in with black paint, the middle row is *champlevé* and filled in with bright red paint. Six fragments found scattered by the NE front of the First Dynasty wall of the Ziggurat terrace. Cf. Pl. 44, U.18260. (L.BM.124510-11.) (P.32.40.17-18.) (B.9529.)
- U.17631 White obsidian pin or stud, l. 0.024 m. From the filling of the First Dynasty Ziggurat terrace. (B.9541.)
- U.17635 Celt, schist, 0.04 m. x 0.04 m., from between the two boundary walls of the 2nd Archaic terrace, Ziggurat. (B.9541.)
- U.17637 Stone vase, fragment of, in basic diorite, carved all over with a pattern of raised dots and meanders. In the soil of the Royal Cemetery area. (B.30663.)
- U.17640 Bead, steatite, oblong with incised ornament, l. 0.023 m. Between the outer walls of the 2nd Archaic level, Ziggurat terrace. (B.9768.)
- U.17646 Mace-head of fine white limestone, a flat disk with mushroom stem resembling Egyptian types of First Pre-dynastic date. Diam. 0.11 m. With it about 70 beads of crystal, agate, carnelian, steatite and granite. Brought in and said to have been found together in a small mound not far from Battha station, south of Abu Drehm. Cf. Pl. 44, U.18223. (B.9508.)
- U.17664 Celt, schist, 0.035 m. x 0.03 m. Ziggurat terrace, 2nd Archaic level. (B.20760.)
- U.17680 Two ear-studs, obsidian, ht. 0.01 m., diam. 0.028 m. Ziggurat terrace, 2nd Archaic level. (B.9528.)
- U.17689a Clay jar-lid, of green clay with design in black paint; diam. 0.07 m. Ziggurat terrace, filling of the archaic levels. Pl. 16. (B.25135.)
- U.17693 Bead, steatite, oblong, l. 0.02 m., gable topped with incised pattern. Ziggurat terrace, 1st Dynasty level. Pl. 44. (P.32.40.312.)
- U.17698 Celt, green basic diorite, 0.33 m. x 0.27 m. Diqqiqqeh. (B.20755.)
- U.17703 Celt, of banded green jasper, 0.046 m. x 0.033 m. Archaic level below the Royal Cemetery. (P.32.40.105.)
- U.17711 Bead, steatite, with scratched pattern; 0.02 m. x 0.024 m. Diqqiqqeh. Pl. 28. (B.9767.)
- U.17712 Obsidian pin or stud, l. 0.026 m., Ziggurat terrace, filling of archaic levels. (P.32.40.138.)
- U.17714 Flint arrow-head, leaf-shaped, l. 0.037 m. Ziggurat terrace, filling of archaic levels. (B.30930.)
- U.17717 Limestone fragment with remains of inscription in semi-pictographs. 0.08 m. x 0.05 m. Diqqiqqeh. (P.32.40.436.)
- U.17723 Two flint arrow-heads, l. 0.17 m. and 0.16 m. Surface finds. Pl. 13.
- U.17725 Chert arrow-head, barbed type, l. 0.034 m. Ziggurat terrace, 2nd Archaic level. Pl. 13. (P.32.40.86.)
- U.17728 Flint tools, miniature, a set of six. Diqqiqqeh. v. Pl. 13.
- U.17729 Clay ear-stud, diam. 0.027 m. Ziggurat terrace, 2nd Archaic level. (P.32.40.458.)
- U.17731 Clay bead, rhomboid, l. 0.021 m., with incised pattern. Ziggurat terrace, 2nd Archaic level. Pl. 28. (B.9765.)
- U.17743 Bead, steatite, oval and convex, l. 0.016 m., with incised border. Ziggurat terrace, 2nd Archaic level. Pl. 28. (P.32.40.313.)
- U.17754 Fragment of shell inlay engraved with 'mountain' pattern of overlapping scales. Diqqiqqeh. Pl. 44. (B.9539.)
- U.17755 Clay ear-studs, two, one of normal type as Pl. 16, U.14466, and one mushroom-shaped, diam. 0.026 m. Ziggurat terrace, 2nd Archaic level. (B.45380.)
- U.17756 Clay ear-studs, two, nail-shaped type. Ziggurat terrace, 2nd Archaic level. Cf. Pl. 15, U.14970. (B.30693.)
- U.17764 Two clay ear-studs, (A) ht. 0.014 m., diam. 0.028 m. (B) ht. 0.013 m., diam. 0.014 m. Ziggurat terrace, 2nd Archaic level. Pl. 15.
- U.17792 Copper adze or hoe, l. 0.09 m., width 0.06 m., Loose in the soil in the Royal Cemetery area. Date probably Sargonid. (B.30655.)
- U.17825 Clay tool (?), a flat and thin oval, 0.11 m. x 0.037 m., with one edge toothed like a carder; on one side a design in black paint repeating the outline of the instrument. Ziggurat terrace, against the face of the courtyard wall on the NW side, 2nd Archaic level. Pl. 16. (B.18777.)
- U.17829 Stela of black, white and red granite, oval-topped, ht. 0.25 m., width 0.25 m. On the front face a seated deity with attendant, on each narrow side a standing human figure, on the back a crudely cut inscription of Ur-Nina. The carving has been done not by cutting but by grinding the stone, and is very summary; part of the inscription seems to have been deliberately effaced. Found in the west corner of the Temenos against the outer face of the NE wall of Sin-balatsu-iqbi's building under the floor of Nebuchadnezzar's corner fort. Pl. 39; v. p. 46. (B.13246.)
- U.17832 Statuette of a seated bull, white calcite, l. 0.17 m., ht. 0.075 m. In the top of the back is a square hole to take an upright, probably the tenon of a standing figure; the muzzle of the animal is damaged by decay. Found together with U.17833-42 in a clay pot buried in the floor of the courtyard of the building on the NW side of the Ziggurat, 1st Dynasty level. Pl. 38. V. p. 43. (L.BM.123139.)

- U.17833 Zoöomorphic seal, calcite, in the form of a reclining dog, originally painted bright red and the eyes filled with black; the beast has a ruff and a bushy tail and a hole is pierced from the top of the back to the stomach; l. 0.065 m., width 0.04 m. Underneath is a design (much perished) of animals, cut mostly with the drill-point. Ziggurat terrace, 1st Dynasty level, v. U.17832. Pl. 38. (B.11108.)
- U.17834 Figurine of seated calf, white calcite, l. 0.035 m., ht. 0.03 m., the animal in profile with the head turned outwards over the shoulder. Ziggurat terrace, 1st Dynasty level, v. U.17832. Pl. 38. (B.20538.)
- U.17835<sup>a,b</sup> Two zoöomorphic seals of white calcite (originally painted red) in the form of lion's heads, 0.05 m. x 0.045 m.; pierced for suspension; the under side crudely engraved (mostly with the drill-point) with animal figures. Ziggurat terrace, 1st Dynasty level, v. U.17832. Pl. 38. (B.11109.) (P.32.40.308.)
- U.17836 Object in white calcite, shaped like a cow-bell, but solid, with two rings for suspension; in the holes were traces of reed or fibre cord. Ht. 0.063 m., diam. 0.052 m. Ziggurat terrace, 1st Dynasty level, v. U.17832. Pl. 15. (B.20748.) Possibly an "eye" idol.
- U.17837 Toilet-vase of white calcite in the form of twin vases cut from the single block; ht. 0.022 m., total l. 0.07 m. Ziggurat terrace, 1st Dynasty level, v. U.17832. Cf. Pl. 31, U.19529. (B.21781.)
- U.17838 Stone vase, white calcite, miniature, Type RC.13, ht. 0.04 m. Ziggurat terrace, 1st Dynasty level, v. U.17832. (B.21782.)
- U.17839 Copper instrument, possibly a razor, l. 0.08 m., width 0.05 m. the tang fairly thick, all edges thin and apparently cutting edges. Ziggurat terrace, 1st Dynasty level, v. U.17832. Pl. 30.
- U.17840 Copper disk, perhaps a mirror, of very thin metal with the edges turned over as if to secure it to a wooden back; diam. 0.135 m. To it were attached by corrosion fragments of a second instrument resembling U.17839. Ziggurat terrace, 1st Dynasty level, v. U.17832. (B.30654.)
- U.17841 Figurine of veined reddish calcite, broken and the surface much decayed, ht. 0.055 m.; apparently a human figure very summarily treated with drilled eye-holes. Ziggurat terrace, 1st Dynasty level, v. U.17832. Pl. 38. (B.30660.)
- U.17842 Beads, a mixed lot of carnelian tubes, double conoids, date-shaped and rings, faceted date-shaped and barrels, balls of glazed frit, lapis-lazuli tubes, rings and ovals and some mixed beads of apatite, quartzite, shell, agate and crystal. Found with U.17832. (L.BM.123151-2, 123156, 123158, 123166.) (P.32.40.237-8, 240-2.)
- U.17860 Amulet of glazed frit in the form of a spread eagle; the glaze perished; ht. 0.039 m. Diqdiqqeh. Pl. 28. (L.BM.123218.)
- U.17879 Copper object of uncertain use, a hollow sphere with projecting knobs at top and bottom laterally pierced in directions at right angles to each other, and two rows of triangular perforations; ht. 0.093 m. Found loose in the soil of the Royal Cemetery area about 5.50 m. below the surface. Pl. 29. (B.25144.)
- U.17888 Terra-cotta figurine, fragment of, moulded; nude female figure with hands clasped below breast, the body below the waist missing; archaic type with sharp and prominent nose. Found together with gold and other beads in a hole in the plano-convex mud-brick wall running over the grave. PG/1850 (v. *Ur Excavations*, Vol. II, p. 212) in which was the foundation-deposit of copper heads of cattle. (B.29910.)
- U.17890 Stone vase, fragment of, in grey steatite carved in relief on the outside; there remain parts of the figures of a gazelle (?) and of the head of a man; poor rough work. c. 0.05 m. x 0.045 m. Found in top soil. Pl. 36. (P.32.40.455.)
- U.17894 Terra-cotta figurine, fragment of; human figure with face, arms and legs missing; on the body a criss-cross pattern in black paint; ht. 0.055 m. Against the stone face of the 1st Dynasty Ziggurat platform. (L.BM.123220.)
- U.17900 Cylinder seal, steatite, Vol. X, No. 226. Loose in soil in the Royal Cemetery area. (B.14530.)
- U.17901 Silver pin, Type RC.1, l. 0.102 m. Loose in soil in the Royal Cemetery area. (B.30657.)
- U.17902 Gold ear-rings, small lunate type, (RC.2); diam. 0.012 m. PG/1932/78. (L.BM.123132.)
- U.17903 Gold bracelet, plain metal, round in section, diam. 0.04 m. PG/1932/77. (B.9059.)
- U.17905 Beads; carnelian tubes and ball, paste ball, marble date-shaped and chalcedony flattened oval. PG/1932/75. (P.32.40.246.)
- U.17923 Stamp seal, pink limestone, rhomboidal, 0.03 m. x 0.02 m., with linear pattern. Diqdiqqeh. Pl. 28. (B.30692.)
- U.17927 Bone toggle, lathe-turned, l. 0.035 m. PG/1932/80. (B.20972.)
- U.17929 Celts, polished stone, nine examples in diorite, schist, shale and jasper. Diqdiqqeh. Pl. 14. (P.32.40.120-2.)
- U.17931 Clay rattle, l. 0.064 m. Loose in soil of the Royal Cemetery area. (B.36284.)
- U.17934 Flint implements, mostly miniature, 13 in all, from Reijibeh X. Pl. 13. (B.45377.)

- U.17935 Celts of polished diorite, basalt, limestone and jasper, 7 in all. Reijibeh X. Pl. 14. (L. *BM.* 124525-6 and P.32.40.106-8.)
- U.17936 Celt, chipped flint, almost straight-sided. Reijibeh X. (P.32.40.79.)
- U.17938 Flint hoe with unusually long tang. Reijibeh X. (P.32.40.81.)
- U.17943 Celts of polished diorite, basalt, jasper, steatite and quartzite, 19 in all. Reijibeh X. Pl. 14. (B.20749, 20753, 20758, 20762-3; L. *BM.* 124514-21; P.32.40.109-115.)
- U.17948 Palette, rectangular and concave, ground out of flint; 0.047 m. x 0.038 m. Reijibeh X. (B.18776.)
- U.17950 Flint hoe, the edges partly chipped but the tool ground on both sides; Reijibeh X. (P.32.40.116.)
- U.17952 Ear-stud, white marble, the top strongly convex; ht. 0.019 m., diam. 0.034 m. Diqdiqqeh. (L. *BM.* 124527.)
- U.17965 Tool (or amulet?) ground out of sandstone, the sides fairly flat. Ht. 0.065 m., width 0.054 m. Reijibeh X. Pl. 14. (B.30659.)
- U.17972 Palettes, two, of steatite, rectangular and slightly concave; 0.065 m. x 0.054 m. Reijibeh X. Pl. 15. (B.30659 & P.32.40.139.)
- U.17973 Celt, miniature, of obsidian, 0.023 m. x 0.015 m. Diqdiqqeh. (L. *BM.* 124513.)
- U.17975 Flints, triangular and leaf-shaped arrow-heads, flakes and miniature implements, 12 in all. Reijibeh X. (B.45378-9; P.32.40.88, 89, 91-100.)
- U.17979 Celts, of polished diorite, jasper, etc. Reijibeh X. (L. *BM.* 124522-4; P.32.40.118.)
- U.17981-5 Terra-cotta cones for wall inlay. From the lower levels at Ur. Pl. 15.
- U.18085 Terra-cotta figurine, upper part of only; nude female figure of normal al'Ubaid type, standing with head thrust forwards, broad shoulders (the arms missing) widened like wings; eyes strongly aslant, the top of the head rising in a peak. Ht. 0.043 m. Ur surface. (P.32.40.20.)
- U.18097 Terra-cotta figurine of a bull, hand-modelled in green clay with details in black paint. L. 0.115 m., ht. 0.065 m. Ur surface. (L. *BM.* 123242.)
- U.18118 Stone bowl, dark steatite, ht. 0.055 m., diam. of rim 0.136 m. The outside is carved in relief with a procession of five oxen standing with the bodies in profile carved in low relief and the heads turned outwards in three-quarter round; over the back of each animal is an ear of barley. A chip is missing from the (plain) rim and a larger chip has broken away the head of one animal. Very fine work. Found in a layer of ashes in the ruins of a Persian house north of the Ziggurat. Pl. 35, v. pp. 31, 52. (B.11959.)
- U.18169 Terra-cotta figurine, fragment of; the head, and body to the waist, of a nude female; the skull elongated in dome-like fashion, the eyes aslant. Ht. 0.045 m. Reijibeh X. Pl. 21. (B.25134.)
- U.18194 Spindle-whorl of dark steatite with linear pattern slashed on the upper convex surface. Diam. 0.06 m. Reijibeh X. Pl. 16. (B.20483.)
- U.18210 Head of a vulture, in mottled dark steatite; the eyes hollowed to receive inlay. The back of the head is smoothly finished with no sign of any possible attachment to a body, so it may have been used as a weight or amulet (?) L. 0.048 m., ht. 0.02 m. al'Ubaid. Pl. 27. (B.16540.)
- U.18220 Lion's head in white limestone, having a tenon behind pierced for attachment to the body; fine miniature work, the surface somewhat decayed. L. 0.014 m., ht. 0.012 m. Diqdiqqeh. (B.16533.)
- U.18223 Mace-head, of very hard and fine white limestone, flat mushroom-shaped disk, diam. 0.093 m. x 0.108 m. (irregular), ht. 0.017 m.; a hole, apparently intentional, pierces the disk between the centre and one edge of the rim. Brought in from Khidr. Same type as U.17646. Pl. 44. (L. *BM.* 124422.)
- U.18225 Gold bar, rectangular in section, 0.002 m. x 0.001 m., and 0.076 m. long, plain; one end hammered flat, the other end bent and broken. Ziggurat terrace, NE front, 2nd Archaic level. (B.16470.)
- U.18226 Sheet gold, a strip of fairly heavy metal 0.155 m. long and 0.018 m. wide at one end, diminishing to a point at the other; it has been bent double lengthwise as if to form an edging, but the sharp point is solid. Ziggurat terrace, NE front, 2nd Archaic level. (B.16469.)
- U.18232 Stone vase, fragments of, in stalagmitic calcite with deeply coloured veining. On it, part of an inscription: *to the goddess Geštin (?) Ur-Pa-bil-sag*, King of U[r] . . . Ziggurat terrace, at the bottom of the rubbish layer used to level the Ur-Nammu terrace near the (Babylonian) "Boat Shrine:" other fragments lay 0.30 m. above the 1st Dynasty floor. (L. *BM.* 124348.)
- U.18236 Gold foil (very thin sheet metal) folded up into a stick l. 0.057 m. Ziggurat terrace, NE front, 1st Dynasty level. (B.16464.)
- U.18237 Terra-cotta figurine, upper part of, hand-modelled; male figure with folded hands. Ziggurat terrace, upper soil. (P.33.35.13.)
- U.18251 Shell inlay, fragment of; 0.056 m. x 0.021 m., the top broken away. On one side there is faintly engraved a human figure wearing the *kaunakes* and advancing rt., the head missing; on the other is plain grooving as of the hair pattern, probably from the flounce of a *kaunakes* skirt; the piece has been re-used and the figure subject is the older work. Ziggurat terrace, 1st Dynasty level, NE front. (L. *BM.* 124414.)

- U.18260 Shell inlay, fragments of, with scale or "mountain" pattern, the curves outlined with double incised lines which were filled in with black, but the middle row *champlevé* and filled with red paint; ht. of bands 0.029m. Cf. U.17625. Ziggurat terrace, found in the square pit filled with limestone blocks, above the stones, 2nd Dynasty level. Pl. 44. (B.16510-13.)
- U.18294 Mace-head, bitumen, pear-shaped with knob at the top, ht. 0.075 m., diam. 0.075 m. Ziggurat terrace, on the floor of the 1st Dynasty courtyard BB. Pl. 15. (B.30658.)
- U.18297 Clay nail (?), the top is broken but seems to have been cup-shaped, and there are 3 bands of black paint round the upper part of the stem. L. 0.10m. Ziggurat terrace, in the packing below the floor of the 2nd Archaic level. Pl. 15. (B.16431.)
- U.18299 Fragment of male head sculptured in diorite. The face is destroyed and there remain only part of the rt. ear, rt. eyebrow and inner corner of rt. eye; round the head was a broad high fillet treated, like the crown of the head, with small ringlets. Ht. 0.21 m., greatest diam. 0.225 m. Very fine work of the Gudea type. Ziggurat terrace, above the 3rd Dynasty rubbish stratum. Pl. 42. (B.30680.)
- U.18308 Stone bowl, white calcite, fragment of; on it a complete inscription of Rimush. Ziggurat terrace rather high up in the filling of the 1st Dynasty room FF. (B.16702.)
- U.18309 Inlay, fragment of, in white limestone; a man, naked except for a loin-cloth, kneeling on one knee and wielding a paddle or punt-pole; the head missing. Ht. 0.09m., width 0.065 m. Ziggurat terrace, in the burnt ashes on the floor of the 1st Dynasty room GG. Pl. 39. (B.16435.)
- U.18312 Stone vase, fragment of, in dark steatite originally inlaid all over in an imbricated pattern with small shell plaques of which the centres were of a different material Jamdat Nasr technique. Found in the rubbish overlying the Ziggurat platform, lower levels. (B.14626.)
- U.18313 Inlay, fragments of, in grey steatite, with a hair pattern, from the head or beard of a large figure; the largest piece 0.095 m. x 0.065 m. Ziggurat terrace, on the floor of the 1st Dynasty room FF. Pl. 44. (B.16500-01.)
- U.18314 Inlay, 2 fragments of, in grey steatite, with hair pattern, forming the greater part of the back of the head of a large figure; ht. 0.075 m., width 0.08m. Ziggurat platform, on the floor of the 1st Dynasty room FF. Pl. 44. (L. BM. 124423-4.)
- U.18323 Terra-cotta figurine, hand modelled, a rudimentary human figure with eyes applied in the form of pellets of clay; ht. 0.038m. Ziggurat terrace, in the filling of the 1st Dynasty level. Pl. 23. (B.29736.)
- U.18324 Gold handle (?); a ring of metal deeply fluted with one plain end which is flattened out at right angles to the ring as if for attachment; on it is a cross lightly engraved. Length 0.023 m., width 0.008m. Ziggurat terrace, on the top of the SE wall of the 1st Dynasty room FF. Pl. 30. (P.33.35.156.)
- U.18328 Whetstone, of lapis-lazuli on a gold ring; l. 0.11 m., diam. 0.012 m. From a grave of the Royal Cemetery period in the side of Pit W. (B.16539.)
- U.18335 Copper bolt, the shaft circular in section, the head gilded; l. 0.057 m., diam. of head 0.013 m. Ziggurat terrace, on the floor of the 1st Dynasty room GG. (B.16463.)
- U.18337 Stamp seal, steatite, Vol. X, No. 14. In Stratum SIS.5 in the Royal Cemetery area. (P.33.35.169.)
- U.18338 Miniature wig, carved in the round in dark steatite; complete. The hair is parted in the middle, then confined by 3 broad braided tresses wound round the head; a fringe comes over the forehead, the back hair falls in a plaited mass. Ht. 0.014 m. Ziggurat terrace, on the floor of the 1st Dynasty room FF. Pl. 27.
- U.18340 Calf's head, carved in dark steatite; the neck is pierced horizontally for attachment, the eyes hollowed for inlay and there is a hole for inlay in the forehead; good archaic work. L. 0.032 m. Diqdiqqeh. Pl. 27. (P.33.35.162.)
- U.18341 Stamp seal, zoöomorphic, of grey steatite; the seal is in the form of a couchant animal carved in fairly high relief; the hind quarters are complete, the fore quarters only lightly sketched, and there is no head; the rounding off of the stone at the shoulders shews that there never was a head. On the under side are two signs crudely engraved. L. 0.029 m. Diqdiqqeh. Pl. 27. (P.33.35.164.)
- U.18347 Pendant, a pear-shaped carnelian bead strung on a slender gold stem with rounded cap above; total l. 0.018m. Ziggurat terrace, on the floor of the 1st Dynasty room FF. Vol. V, Pl. 66. (P.33.35.155.)
- U.18352 Amulet; a tortoise, of grey steatite, l. 0.023m. Ziggurat terrace, on the floor of the 1st Dynasty room FF. Vol. V, Pl. 66. Herein Pl. 27. (B.16531.)
- U.18362 Amulet; a pig (?) crudely carved in shell; l. 0.022m., ht. 0.014 m. Ur surface. Pl. 27. (B.16538.)
- U.18369 Stone vase, fragment of, in white limestone; carinated bowl on a square pedestal like a four-legged table; the legs broken off; diam. 0.13 m., total ht. 0.07 m. Royal Cemetery area, Pit W, Jamdat Nasr level. Pl. 44. (B.30664.)

- U.18370 Terra-cotta object, oval, with incised design; l. 0.055m. Royal cemetery area, Pit W, below SIS 7. Pl. 15. (B.16432.)
- U.18390 Terra-cotta figurine of an animal; on one flank are incised signs . L. 0.035 m., ht. 0.03 m. Royal Cemetery area, Stratum SIS 4-5. Pl. 21. (B.29737.)
- U.18391 Terra-cotta figurine of an animal; on the rt. shoulder is an incised sign . L. 0.055 m., ht. 0.045 m. Royal Cemetery area, Stratum SIS 6-7. Pl. 21. (P.33.35.56.)
- U.18392 Clay roundel, very roughly made, with archaic signs incised on one face; diam. c. 0.045 m. Pit W, Stratum SIS 4-5.
- U.18415 Terra-cotta figurines, crudely modelled in dark clay; nude female figures, steatopygous, the heads very small, the arms thick and short; (A), ht. 0.049 m., (B) ht. 0.025 m., the legs missing. Pit W, Stratum SIS 4-5. Pl. 21. (B.29738.) (L. *BM.* 124452.)
- U.18416 Terra-cotta figurine, crudely modelled in dark clay; human figure made to the top of the hips only, with a hole for attachment in the flat base; head very small and bird-like, arms like wings. Ht. 0.055 m. Pit W, Stratum SIS 4-5. Pl. 21. (P.33.35.16.)
- U.18417 Terra-cotta figurine, crudely modelled, a nude female (to the hips only), the breasts attached in "snow-man" technique, the hair also applied with a ribbon of clay, the nose pinched to a beak, the arms wing-like; ht. 0.05 m. Pit W, Stratum SIS 4-5. Pl. 21. (P.33.35.17.)
- U.18418a Terra-cotta figurine, crudely modelled; female figure (to the hips only) with beak-like nose, no eyes, the hair pinched out to a flat horizontal ridge, the arms wing-like; ht. 0.06 m. Pit W, Stratum SIS 4-5. (P.33.35.18.)
- U.14818b Terra-cotta figurine, fragment of, head and neck only; similar to U.18418a. Ht. 0.04 m. Pit W, Stratum SIS 4-5. (B.16415.)
- U.18419 Terra-cotta figurine, fragment of, crudely modelled in dark clay; draped figure, the fringe of the skirt rendered by incised lines; the arms wing-like; head missing; ht. 0.048 m. Pit W, Stratum SIS 4-5. (B.16415.)
- U.18419 Terra-cotta figurine, fragment of, crudely modelled in dark clay; draped female, head missing; the arms wing-like, the fringe of the skirt rendered by incised lines; ht. 0.048 m. Pit W, Stratum SIS 4-5. (B.16422.)
- U.18420 Terra-cotta figurines, 5 in all; crudely hand-modelled human figures with no heads, flat wing-like arms and flat bases; hts. 0.057 m. - 0.026 m. Pit W, Stratum SIS 4-5. Cf. Pl. 21, U.18416. (B.; L. *BM.* 124453-4; P.33.35.19.)
- U.18421 Terra-cotta figurine, crudely modelled, a human figure down to the hips, apparently draped and with a scarf surrounding the neck and hanging down in front; no face. Ht. 0.067 m. Pit W, Stratum SIS 4-5. (B.29741.)
- U.18422 Terra-cotta figurines of animals, 28 in all, crudely hand-modelled. Pit W, Stratum SIS 4-5. (B.29703-22.)
- U.18423 Terra-cotta head of an animal, modelled in dark clay, the eyes incised, the mouth and nostrils carefully rendered; good work; ht. 0.03 m., l. 0.04 m. Pit W, Stratum SIS 4-5. Pl. 21. (P.33.35.57.)
- U.18424 Terra-cotta head of an owl, hand-modelled, with spike below for attachment to a body; ht. 0.07 m., width 0.055 m. Pit W, Stratum SIS 4-5. (L. *BM.* 124455.)
- U.18425 Beads; carnelian rings. JNG/40. (L. *BM.* 124446.)
- U.18426 Copper pin, l. 0.27 m. JNG/40. (L.)
- U.18427 Beads; polished rings of carnelian. JNG/25. (P.33.35.149.)
- U.18428 Beads; carnelian rings. JNG/44. (B.16722.)
- U.18429 Stone bowl, limestone, Type JN.16, ht. 0.037 m., diam. c. 0.105 m. JNG/25. (B.16920.)
- U.18430 Beads; carnelian rings, shell rings and shell tubes. JNG/38. (L. *BM.* 124450.)
- U.18431 Stone bowl, basic diorite, Type JN.20, ht. 0.045 m., diam. 0.11 m. JNG/38. (B.16817.)
- U.18432 Beads; polished rings of carnelian. JNG/35b. (B.16725.)
- U.18433 Beads; carnelian cylinders. JNG/33. (P.33.35.148.)
- U.18434 Stone bowl, fine limestone, Type JN.4, ht. 0.09 m., diam. 0.11 m. Pit W, from a plundered JNG grave. (B.16814.)
- U.18435 Stone bowl, fine limestone, Type JN.12, ht. 0.08 m., diam. 0.175 m. JNG/16. (B.16850.)
- U.18436 Stone vase, alabaster, Type JN.50, ht., 0.035 m., diam. 0.05 m. JNG/5. (B.16839.)
- U.18437 Stone vase, alabaster, Type JN.55, ht. 0.07 m., diam. 0.10 m. JNG/2. (B.16820.)
- U.18438 Beads; carnelian cylinders, large and small, lapis-lazuli balls, flattened balls and cylinders, one chalcedony flattened oval, one carnelian date-shaped and one agate date-shaped. JNG/42. (B.16476.) (L. *BM.* 124448.)
- U.18439 Beads; one large shell cylinder, a date-shaped calcite bead flattened on one side, carnelian rings, some very small and a few large shell rings, one large haematite ring. JNG/66. (B.16717.)

- U.18440 Beads; large carnelian rings and two curved tubes of shell. JNG/62. (B.16724.)
- U.18441 Beads; carnelian rings; also 2 black steatite barrels and 1 shell cylinder. JNG/52a. (B.16727.)
- U.18442 Stamp seal, steatite, Vol. X, No. 10. JNG/42.
- U.18443 Stone cup, diorite, Type JN.7, ht. 0.03 m., diam. 0.044 m. Pit W, loose in the soil amongst the JNG/graves. (B.16837.)
- U.18444 Stone bowl, miniature, Type JN.24, ht. 0.03 m., diam. 0.07 m. Pit W, from a plundered JNG grave. (L.BM.124440.)
- U.18445 Beads; carnelian rings. JNG/45. (B.16729.)
- U.18446 Stone bowl, basic diorite, Type JN.19, ht. 0.035 m., diam. 0.105 m. JNG/62. (L.BM.124442.)
- U.18459 Beads; carnelian rings, shell rings, 2 short tubes of pink limestone, 1 agate and 1 dark steatite cylinder. JNG/90. (B.16721.)
- U.18459a Stone bowl, of translucent alabaster, Type JN.3, decorated with a narrow notched ridge; ht. 0.07 m., diam. 0.11 m. JNG/348.
- U.18460 Beads; carnelian rings, lapis-lazuli rings, 2 lapis cylinders and one lapis ball. From an un-numbered JNG grave in the side of Pit W, of which only the head could be excavated. (B.16479.)
- U.18461 Copper pin, l. 0.11 m., straight, with decorated head. JNG/78b. Pl. 30. (P.33.35.79.)
- U.18462 Beads; carnelian and shell rings, a barrel of dark steatite and some very long tubes of paste (?), decayed. JNG/82.
- U.18463 Cylinder seal, of dark red stone (jasper?); Vol. X, No. 73. JNG/78b. (L.BM.124406.)
- U.18464 Beads; 3 long "spacers" made from the lips of cowrie shell together with shell tubes and haematite barrels. JNG/88.
- U.18465 Beads; carnelian rings and one cylinder. JNG/74. (P.33.35.152.)
- U.18466 Stone vase, grey steatite, Type JN/60, ht. 0.033 m., diam. 0.038 m. Pit W, loose in the soil amongst the JNG graves. (L.BM.124442.)
- U.18467 Stone bowl, translucent calcite, Type JN.9, ht. 0.07 m., diam. 0.115 m. JNG/26. (B.16918.)
- U.18468 Stone bowl, basic diorite, Type JN.12, ht. 0.045 m., diam. 0.135 m. JNG/46. (B.16901.)
- U.18469 Stone bowl, white limestone, Type JN.17, ht. 0.04 m., diam. 0.11 m. JNG/5. (B.16919.)
- U.18470 Stone bowl, white limestone, Type JN.17, ht. 0.05 m., diam. 0.135 m. JNG/5. (B.16921.)
- U.18471 Stone cup, basic diorite, Type JN.40, ht. 0.09 m., diam. 0.115 m. JNG/53. (B.16813.)
- U.18472 Stone bowl, green basic diorite, Type JN.15, ht. 0.06 m., diam. 0.17 m. JNG/42. (B.16795.)
- U.18473 Beads; carnelian rings. JNG/84. (B.16719.)
- U.18474 Beads; carnelian rings. JNG/69. (B.16715.)
- U.18475 Beads; carnelian rings. JNG/65,84. (B.16718.)
- U.18476 Beads; carnelian rings and one cylinder. JNG/ un-numbered. (L.BM124451.)
- U.18477 Bone piercer, mounted in its original bitumen handle; l. 0.051 m. Pit W, on level of the Jamdat Nasr graves. Pl. 15.
- U.18478 Stone bowl, greenish diorite, Type JN.8, ht. 0.07 m., diam. 0.10 m. JNG/73. (B.16908.)
- U.18479 Stone bowl, basic diorite, Type JN.20, ht. 0.055 m., diam. 0.10 m. JNG/47. (B.16909.)
- U.18480 Stone bowl, basic diorite, Type JN.16, ht. 0.03 m., diam. 0.10 m. JNG/82. (B.16804.)
- U.18481 Stone vase, greenish steatite, Type JN.61, ht. 0.04 m., diam. 0.042 m. JNG/73. (B.16836.)
- U.18482 Beads; small carnelian rings and a few lapis-lazuli rings. JNG/93. (L.BM.124447.)
- U.18484 Beads; carnelian rings. JNG/100. (P.33.35.150.)
- U.18485 Beads; very small balls of blue-glazed frit. JNG/103. (P.33.35.151.)
- U.18486 Stone bowl, basic diorite, Type JN.4, ht. 0.08 m., diam. 0.075 m. JNG/42. (B.16803.)
- U.18487 Stone bowl, green-grey slaty stone, Type JN.27, ht. 0.055 m., diam. 0.12 m. JNG/22. (L.BM.124434.)
- U.18488 Stone bowl, basic diorite, Type JN.17, ht. 0.045 m., diam. 0.115 m. JNG/15. (B.16805.)
- U.18489 Stone vase, white calcite, Type JN.55, ht. 0.045 m., diam. 0.07 m. JNG/42. (B.16898.)
- U.18491 Stone bowl, basic diorite, Type JN.11, ht. 0.047 m., diam. 0.10 m. Pit W, loose in the soil amongst the JNG graves. (B.16915.)
- U.18497 Shell handle in the form of an animal, l. 0.073 m. Reijibeh, found in a grave together with U.18498. Pl. 27. (L.BM.124412.)
- U.18498 Amulet; shell figurine of a bull carved in low relief; ht. 0.024 m. Reijibeh; found in a grave together with U.18497. Pl. 27. (P.33.35.161.)
- U.18499 Amulet, shell, in the form of a fish (the mouth broken away); l.0.022 m. Diqiqqeh. Pl. 28.
- U.18501 Beads; natural shell (gasteropods, etc.) pierced for stringing. JNG/42.
- U.18503 Stone bowl, basic diorite, Type JN.4, ht. 0.092 m., diam. 0.14 m. JNG/92. (B.16811.)
- U.18504 Stone cup, basic diorite, Type JN.30, ht. 0.115 m., diam. 0.11 m. JNG/72. (B.16768.)
- U.18505 Stone bowl, white limestone, Type JN.12, ht. 0.09 m., diam. 0.165 m. JNG/24. (B.16888.)
- U.18506 Stone vase, banded calcite, Type JN.56, ht. 0.10 m., diam. 0.13 m. JNG/42. (B.16776.)
- U.18507 Stone bowl, basic diorite, Type JN.14, ht. 0.04 m., diam. 0.16 m. JNG/84. (B.16916.)

- U.18508 Stone bowl, basic diorite, Type JN.24, ht. 0.06 m., diam. 0.12 m. JNG/18. Pl. 34. (B.16902.)
- U.18509 Stone bowl, basic diorite, Type JN.13, ht. 0.055 m., diam. 0.16 m. JNG/80. (B.16906.)
- U.18510 Stone bowl, basic diorite, Type JN.5, with slight plate base; ht. 0.105 m., diam. 0.145 m. JNG/104. (B.16826.)
- U.18511 Stone bowl, basic diorite, Type JN.8, ht. 0.067 m., diam. 0.097 m. JNG/95. (P.33.35.99.)
- U.18512 Stone bowl, diorite, Type JN.5, ht. 0.065 m., diam. 0.21 m. JNG/75.
- U.18513 Stone bowl, white limestone, Type JN.12, ht. 0.05 m., diam. 0.135 m. Pit W, loose in the soil amongst the JNG graves.
- U.18514 Stone bowl, basic diorite, Type JN.12, ht. 0.055 m., diam. 0.145 m. Pit W, loose in the soil amongst the JNG graves. (L.BM.124438.)
- U.18515 Stone bowl, white limestone, Type JN.18, ht. 0.05 m., diam. 0.16 m. JNG/42. (B.16855.)
- U.18516 Stone bowl, banded limestone, Type JN.10, ht. 0.075 m., diam. 0.16 m. JNG/101.
- U.18517 Stone vase, limestone, Type JN.50, ht.0.03 m., diam. 0.03 m. JNG/87. (P.33.35.112.)
- U.18518 Stone bowl, white limestone, rough and irregular, Type JN.11, ht. 0.05 m., diam. 0.12 m. JNG/55. (B.16900.)
- U.18519 Stone bowl, limestone, Type JN.26, the outside left rough, ht. 0.105 m., diam. 0.19 m. JNG/49. (B.16882.)
- U.18520 Stone bowl, white limestone, Type JN.18, ht. 0.055 m., diam. 0.145 m. JNG/44. (B.16922.)
- U.18521 Beads; carnelian rings. JNG/119. (L.BM.124449.)
- U.18522 Beads; carnelian rings and 1 large haematite ring. JNG/112. (B.16728.)
- U.18524 Stone bowl, of rather coarse grey limestone, Type JN.40, ht. 0.045 m., diam. 0.078 m.; on the outside is carved in relief a row of five bulls advancing rt., shewn in profile but with the heads turned outwards; each is attacked from behind by a lion. JNG/120. Pl.31. (B.16494.)
- U.18527 Terra-cotta figurine, fragment of, nude female figure wearing a girdle rendered in black paint; preserved from the waist to the ankles; ht. 0.09 m. Pit W, in the bottom of the Jamdat Nasr grave stratum, just above the clean silt. Pl.22. (P.33.35.20.)
- U.18528 Terra-cotta figurine, head of; drab clay; the back of the head elongated, the eyes aslant; ht. 0.026 m. Pit W, in the Jamdat Nasr grave stratum. Pl.21. (B.29743.)
- U.18530 Stone bowl, white limestone, Type JN.17, ht. 0.07 m., diam. 0.205 m. JNG/94. (B.16903.)
- U.18531 Stone tumbler, basic diorite, Type JN.35, ht. 0.18 m., diam. 0.09 m., Pit W, loose in the soil amongst the JNG graves. (B.16773.)
- U.18532 Stone bowl, limestone, Type JN.20, ht. 0.07 m., diam. 0.16 m. JNG/36. (B.16799.)
- U.18533 Stone bowl, diorite, Type JN.25, ht. 0.05 m., diam. 0.125 m. JNG/2. (B.16913.)
- U.18534 Stone bowl, diorite, Type JN.11, ht. 0.035 m., diam. 0.12 m. JNG/3. (P.33.35.102.)
- U.18535 Stone tumbler, diorite, Type JN.34, ht. 0.105 m., diam. 0.135 m., JNG/6. (B.16827.)
- U.18536 Stone bowl, diorite, Type JN.25, ht. 0.062 m., diam. 0.212 m. JNG/1. (B.16796.)
- U.18537 Stone bowl, basic diorite, Type JN.23, ht. 0.09 m., diam. 0.205 m. JNG/59. (B.16809.)
- U.18538 Stone bowl, basic diorite, Type 7, ht. 0.15 m., diam. 0.175 m. Pit W, loose in the soil amongst the JNG graves (B.16766.)
- U.18539 Stone tumbler, diorite, Type JN.30, ht. 0.09 m., diam. 0.095 m. JNG/116. (L.BM.124436.)
- U.18540 Stone bowl, dark steatite, Type JN.19, ht. 0.05 m., diam. 0.135 m. JNG/97. (B.16806.)
- U.18541 Stone bowl, limestone, Type JN.18, ht. 0.055 m., diam. 0.135 m. JNG/112. (B.16801.)
- U.18542 Stone bowl, white limestone, Type JN.18, ht. 0.05 m., diam. 0.13 m. Pit W, from a plundered JNG grave. (B.16802.)
- U.18543 Stone bowl, basic diorite, Type JN.16, ht. 0.047 m., diam. 0.11 m. JNG/122. (P.33.35.104.)
- U.18544 Stone bowl, pink limestone, Type JN.16, ht. 0.04 m., diam. 0.11 m. JNG/122. (B.16854.)
- U.18545 Stone bowl, diorite, Type JN.27, ht. 0.11 m., diam. 0.18 m. JNG/42. (B.16870.)
- U.18546 Stone bowl, basic diorite, Type JN.30, ht. 0.12 m., diam. 0.13 m. JNG/42. (P.33.35.109.)
- U.18547 Stone bowl, limestone, Type JN.13, ht. 0.06 m., diam. 0.23 m. JNG/34. (B.16823.)
- U.18548 Stone bowl, limestone, Type JN.20, ht. 0.072 m., diam. 0.145 m. JNG/80. (B.16912.)
- U.18549 Stone bowl, white limestone, Type JN.20, ht. 0.05 m., diam. 0.105 m. JNG/105. (P.33.35.106.)
- U.18554 Beads; carnelian rings and coarsely made shell tubes. JNG/10a. (P.33.35.145.)
- U.18555 Beads; long oval strips of cowrie and other shells, shell rings and tubes, large and coarse flat rings of haematite carnelian cylinders and lapis-lazuli cylinders and balls. JNG/17. (P.33.35.146.)
- U.18557 Beads; 100 unfinished beads, rings and cylinders, only roughly chipped to shape and unpierced— one has the hole started but not carried through the stone JNG/4 (B.16487.)
- U.18558 Stone bowl, diorite, Type JN.10 but with slight plate base, ht. 0.09 m., diam. 0.16 m. Pit W, loose in the soil amongst the JNG graves. (B.16924.)
- U.18559 Stone bowl, dark diorite, Type JN.26, ht. 0.095 m., diam. 0.175 m. JNG/93.
- U.18560 Stone bowl, translucent banded white calcite, Type JN.27, ht. 0.115 m., diam. 0.19 m. JNG/123.



- (P.33.35.100.)
- U.18561 Stone bowl, basic diorite, Type JN.11, ht. 0.032 m., diam. 0.08 m. JNG/76. Pl.34. (B.16911.)
- U.18562 Stone bowl, basic diorite, Type JN.9, ht. 0.07 m., diam. 0.095 m. JNG/119. (B.16907.)
- U.18563 Stone bowl, basic diorite, coarse, Type JN.24, ht. 0.067 m., diam. 0.135 m. JNG/104. (B.16910.)
- U.18564 Stone bowl, coarse limestone, Type JN.13, ht. 0.06 m., diam. 0.16 m. JNG/90. (B.16917.)
- U.18570 Copper pin with small ball head, l. 0.07 m.; Pit W, from the Jamdat Nasr grave stratum. (B.16686.)
- U.18571 Stone vase, grey translucent calcite, Type JN.57, ht. 0.14 m., diam. 0.17 m. JNG/42. (B.16777.)
- U.18572 Stone vase, grey translucent calcite, Type JN.59, ht. 0.13 m., diam. of rim 0.15 m.; the rim much chipped. JNG/74. (P.33.35.111.)
- U.18573 Stone vase, translucent grey calcite, Type JN.53, ht. 0.10 m., diam. 0.145 m. JNG/14. (L.B.M.124443.)
- U.18574 Stone bowl, basic diorite, Type JN.10, ht. 0.067 m., diam. 0.14 m. JNG/86. (B.16807.)
- U.18575 Stone tumbler, fine limestone, Type JN.35, ht. 0.165 m., diam. 0.072 m. JNG/90. (P.33.35.108.)
- U.18576 Beads; carnelian rings and one short cylinder of white frit probably originally blue-glazed. JNG/16. (B.16720.)
- U.18577 Stone bowl, limestone, Type JN.8, ht. 0.10 m., diam. 0.16 m. JNG/59. (B.16808.)
- U.18578 Stone bowl, white limestone, Type JN.20, ht. 0.06 m., diam. 0.105 m. JNG/46. (B.16821.)
- U.18579 Stone bowl, limestone, Type JN.25, ht. 0.067 m., diam. 0.18 m. JNG/34. (B.16771.)
- U.18580 Beads; carnelian rings. JNG/130. (P.33.35.147.)
- U.18581 Beads; carnelian rings and one cylinder of black stone. JNG/129. (B.16726.)
- U.18582 Beads; carnelian rings, lapis-lazuli cylinders and 2 white steatite beads. JNG/138. (B.16723.)
- U.18583 Stone bowl, limestone, white with two ochrous yellow bands, Type JN.2, ht. 0.027 m., diam. 0.065 m. The outside is carved as a flower with 12 sharply-pointed petals in high relief; the colour of the stone has been used to increase the flower effect. JNG/136. Pl.34. (P.33.35.98.)
- U.18587 Cylinder seal, limestone, Vol. X, No. 84. In the filling of the 1st Dynasty courtyard on the SW side of the Ziggurat. (B.16440.)
- U.18588 Terra-cotta bead, half of; rectangular, 0.026 m. x 0.013 m., with linear design incised within a border of dots. Pit W, below the silt stratum, level 1.50 m. Pl. 27.
- U.18589 Terra-cotta bead, circular, diam. 0.026 m.; a border of half-circles and inside two bands of zig-zag pattern incised. Pit W, below the silt stratum, level 1.50 m. Pl. 27.
- U.18590 Cylinder seal, shell, Vol X, No. 90. On the floor of the 1st Dynasty courtyard on the SW side of the Ziggurat. (B.16447.)
- U.18591 Stone bowl, basic diorite, Type JN.5, ht. 0.07 m., diam. 0.105 m. JNG/49. (B.16828.)
- U.18592 Stone bowl, basic diorite, Type JN.12, ht. 0.06 m., diam. 0.17 m. JNG/93. (P.33.35.101.)
- U.18593 Stone lamp, translucent white calcite, Type JN.64, ht. 0.035 m., diam. 0.095 m. x 0.075 m. JNG/48. (B.16838.)
- U.18594 Stone bowl, white limestone, Type JN.16, ht. 0.04 m., diam. 0.10 m. JNG/137. (B.16899.)
- U.18595 Stone bowl, fine-grained white limestone, Type JN.18, ht. 0.067 m., diam. 0.23 m. Pit W, loose in the soil amongst the JNG graves. (B.16816.)
- U.18596 Stone bowl, white limestone, Type JN.4, ht. 0.08 m., diam. 0.145 m. x 0.115 m. (it is slightly oval, perhaps owing to distortion). JNG/84. (B.16881.)
- U.18597 Stone bowl, diorite, Type JN.28, ht. 0.10 m., diam. 0.16 m. JNG/42. (B.16767.)
- U.18598 Stone bowl, basic diorite, Type JN.20, ht. 0.06 m., diam. 0.11 m. JNG/59. (B.16925.)
- U.18599 Stone bowl, diorite, Type JN.27, ht. 0.095 m., diam. 0.21 m. JNG/94. (B.16923.)
- U.18600 Stone bowl, basic diorite, Type JN.9, ht. 0.087 m., diam. 0.105 m. JNG/135. (B.16852.)
- U.18601 Stone cup, diorite, Type JN.40, ht. 0.08 m., diam. 0.085 m. JNG/128. (P.33.35.107.)
- U.18602 Stone bowl, basic diorite, Type JN.4, ht. 0.057 m., diam. 0.12 m. JNG/133. (B.16851.)
- U.18603 Stone bowl, basic diorite, Type JN.26, ht. 0.085 m., diam. 0.175 m. JNG/48. (B.16810.)
- U.18604 Stone bowl, blackish-grey fine-grained igneous rock, Type JN.13, ht. 0.052 m., diam. 0.155 m. JNG/128. (B.16794.)
- U.18605 Clay vase, Type JN.32, ht. 0.13 m., painted in three colours with a geometrical design. JNG/129. Pl.26. (L.B.M.124457.)
- U.18606 Clay vase, Type JN.104, ht. 0.20 m., covered with a haematite wash and burnished. In bad condition. JNG/128.
- U.18608 Clay vase, Type JN.158, ht. 0.145 m., of light drab clay on which a crude design in red paint. JNG/129. (P.33.35.4.)
- U.18609 Clay vase, Type JN.57, ht. 0.18 m., light pink surface with design in red paint. JNG/un-numbered. (P.33.35.9.)
- U.18623 Clay pot, painted with red design on the light drab clay; Type JN.121, but with 2 spouts; ht. 0.26 m. Pit W, in the Jamdat Nasr grave stratum. (P.33.35.3.)
- U.18624 Clay cup, Type aU.20, of drab clay with design in black paint; ht. 0.07 m., diam. 0.10 m. Pit W,

- below the silt stratum. Pl. 18. (B.16492.)
- U.18629 Terra-cotta figurine, fragment of, a nude female figure preserved from neck to waist, arms broken. The arms are covered with applied clay pellets probably imitating tattoo marks; ht. 0.03 m. Pit W, below the silt stratum. Pl. 22. (B.16420.)
- U.18630 Stone bowl, limestone, Type JN.20, ht. 0.047 m., diam. 0.10 m. JNG/129. (B.16762.)
- U.18631 Stone bowl, basic diorite, Type JN.16, ht. 0.04 m., diam. 0.10 m. JNG/129. (B.16853.)
- U.18632 Stone bowl, basic diorite, Type JN.4, ht. 0.11 m., diam. 0.18 m. JNG/135. (B.16824.)
- U.18633 Stone bowl, basic diorite, Type JN.15, ht. 0.055 m., diam. 0.17 m. JNG/124. (B.16856.)
- U.18634 Stone bowl, white limestone, Type JN.19, ht. 0.06 m. JNG/130. (B.16799.)
- U.18635 Stone bowl, limestone, Type JN.10, ht. 0.065 m., diam. 0.12 m. Pit W, from a plundered JN grave. (B.16832.)
- U.18636 Stone bowl, limestone, fragmentary, ht. c. 0.08 m. Pit W, from the Jamdat Nasr grave stratum. (B.16815.)
- U.18637 Stone bowl, limestone, Type JN.26, ht. 0.085 m., diam. 0.135 m. JNG/27. (B.16775.)
- U.18638 Stone bowl, coarse pitted limestone, fragmentary, ht. c. 0.10 m. JNG/46. (B.16797.)
- U.18639 Stone bowl, white limestone, Type JN.19, ht. 0.07 m., diam. 0.155 m. JNG/84. (B.16772.)
- U.18640 Stone bowl, limestone, Type JN.20, ht. 0.06 m., diam. 0.11 m. JNG/84. (B.16822.)
- U.18641 Stone bowl, limestone, Type JN.21, ht. 0.052 m., diam. 0.125 m. JNG/94. (B.16770.)
- U.18642 Stone bowl, limestone, Type JN.10, ht. 0.095 m., diam. 0.155 m. JNG/61. (B.16763.)
- U.18643 Stone bowl, limestone, broken, ht. 0.095 m., diam. 0.26 m. Pit W, from the Jamdat Nasr grave stratum. (B.16765.)
- U.18644 Stone bowl, limestone, Type JN.10, ht. 0.072 m., diam. 0.14 m. Pit W, from a plundered JNG grave. (B.16880.)
- U.18648 Stone bowl, limestone, Type JN.22, ht. 0.055 m., diam. 0.14 m. JNG/58. (B.16926.)
- U.18649 Stone bowl, limestone, Type JN.21, ht. 0.04 m., diam. 0.09 m. JNG/58. (B.16818.)
- U.18650 Stone bowl, limestone, Type JN.20, ht. 0.065 m., diam. 0.12 m. JNG/58. (B.17419.)
- U.18651 Stone bowl, fine limestone, Type JN.10, ht. 0.07 m., diam. 0.125 m. JNG/90. (B.)
- U.18652 Stone bowl, limestone, Type JN.21, ht. 0.04 m., diam. 0.10 m. JNG/18. (B.)
- U.18653 Stone bowl, basic diorite, Type JN.16, ht. 0.03 m., diam. 0.09 m. JNG/109. (B.16833.)
- U.18654 Stone bowl, limestone, Type JN.22, ht. 0.06 m., diam. 0.17 m. JNG/84. (B.16760.)
- U.18655 Stone bowl, limestone, Type JN.25, ht. 0.072 m., diam. 0.22 m. JNG/34. (B.16825.)
- U.18656 Stone bowl, limestone, Type JN.6, ht. 0.075 m., diam. 0.16 m. x 0.14 m. (it is slightly oval, probably owing to distortion); JNG/42. (B.16863.)
- U.18657 Stone bowl, white limestone, Type JN.15, ht. 0.05 m., diam. 0.19 m.; the base was broken in antiquity and mended with bitumen. JNG/38. (B.16825.)
- U.18658 Stone tumbler, white limestone, Type 39, ht. 0.13 m., broken and imperfect. JNG/53. (B.16780.)
- U.18659 Stone bowl, basic diorite, Type JN.25, ht. 0.05 m., diam. 0.125 m. JNG/113. (B.16778.)
- U.18660 Stone bowl, limestone, Type JN.12, ht. 0.075 m., diam. 0.23 m. JNG/42. (B.16769.)
- U.18661 Stone bowl, limestone, Type JN.14, ht. 0.055 m., diam. 0.205 m. JNG/35a. (B.16864.)
- U.18662 Stone bowl, limestone, Type JN.21, ht. 0.04 m., diam. 0.11 m. JNG/72b. (B.)
- U.18663 Stone bowl, pink limestone, Type JN.17, ht. 0.05 m., diam. 0.125 m. JNG/43. (B.16831.)
- U.18664 Stone bowl, limestone, Type JN.18, ht. 0.052 m., diam. 0.175 m. JNG/7. (B.16774.)
- U.18665 Stone bowl, limestone, Type JN.18, ht. 0.065 m., diam. 0.23 m. JNG/34. (B.16782.)
- U.18666 Stone bowl, limestone, Type JN.18, ht. 0.06 m., diam. 0.195 m. JNG/55. (B.16783.)
- U.18667 Stone bowl, limestone, Type JN.13, ht. 0.08 m., diam. 0.24 m. JNG/45. (B.16784.)
- U.18668 Stone bowl, limestone, Type JN.18, ht. 0.06 m., diam. 0.16 m. JNG/52b. (B.16785.)
- U.18669 Stone bowl, limestone, Type JN.12, ht. 0.045 m., diam. 0.135 m. JNG/53. (B.16761.)
- U.18670 Stone bowl, limestone, ht. 0.095 m., diam 0.135 m. Much broken. Pit W from Jamdat Nasr grave stratum. (B.16812.)
- U.18671 Stone bowl, limestone, Type JN.12, ht. 0.045 m., diam. 0.115 m. JNG/91 (B.16830.)
- U.18672 Stone vase, translucent white calcite, Type JN.59, ht. 0.04 m., diam. 0.05 m. JNG/48. (B.16835.)
- U.18673 Stone bowl, diorite, Type JN.10, ht. 0.04 m., diam. 0.085 m. JNG/72a. (B.16860.)
- U.18674 Stone bowl, basic diorite, Type JN.18, ht. 0.032 m., diam. 0.095 m. JNG/87. (B.16857.)
- U.18675 Stone bowl, limestone, Type JN.10, ht. 0.047 m., diam. 0.10 m. JNG/29. (B.16858.)
- U.18677 Stone bowl, translucent white calcite, Type JN.4, ht. 0.075 m., diam. 0.12 m. JNG/51. (P.33.35.110.)
- U.18678 Stone bowl, limestone, Type JN.23, ht. 0.06 m., diam. 0.15 m. JNG/74. (B.16800.)
- U.18679 Stone bowl, limestone, Type JN.27, ht. 0.082 m., diam. 0.145 m. JNG/120. (B.16764.)
- U.18680 Stone bowl, grey steatite, Type JN.27, ht. 0.067 m., diam. 0.13 m. JNG/42. (P.33.35.105.)
- U.18681 Stone bowl, limestone, Type JN.27, ht. 0.09 m., diam. 0.175 m. JNG/72a. (B.16819.)

- U.18682 Stone bowl, diorite, Type JN.9, ht. 0.07 m., diam. 0.11 m. JNG/137. (B.16829.)
- U.18683 Stone cup, black steatite, Type JN.28, ht. 0.08 m., diam. 0.12 m. JNG/22. (B.16859.)
- U.18684 Stone bowl, limestone, Type JN.8, ht. 0.06 m., diam. 0.095 m. JNG/20. (B.16760.)
- U.18685 Stone bowl, limestone, Type JN.22, ht. 0.055 m., diam. 0.13 m. JNG/14. (B.16834.)
- U.18688 Stone bowl, coarse basic diorite, Type JN.9, ht. 0.115 m., diam. 0.18 m. JNG/45. (B.16865.)
- U.18689 Stone bowl, limestone, Type JN.12, ht. 0.095 m., diam. 0.22 m. JNG/22. (P.33.35.106.)
- U.18690 Beads; carnelian ball and date-shaped beads and one lapis-lazuli ring. JNG/15. (P.33.35.153.)
- U.18710 Flint arrow-heads, 7 in all, leaf-shaped; from Reijibeh X. (B.16506; L.BM.124444; P.33.35.114-5.)
- U.18712 Flint arrow-heads, 5 in all, barbed; from Reijibeh X. Pl. 13. (B.16507; L.BM.124445.)
- U.18714 Clay vase, Type JN.104, ht. 0.22 m., decorated with vertical stripes of reserved slip. JNG/129. (B.16490.)
- U.18715 Stone bowl, pink limestone, Type JN.4, ht. 0.07 m., diam. 0.12 m. JNG/10.
- U.18716 Stone bowl, limestone, Type JN.16, ht. 0.022 m., diam. 0.085 m. Pit W, from a plundered JNG grave. (B.16904.)
- U.18717 Stone vase, white marble, Type JN.50, ht. 0.06 m., diam. 0.06 m. JNG/78a. (B.16861.)
- U.18718 Flint arrow-head of angular outline, only 0.002 m. thick; from Reijibeh X. Pl. 13. (P.33.35.113.)
- U.18721 Flint hoes, 23 in all, of the three main types illustrated on Pl. 12. Reijibeh X. (B.30666; L.BM.129088-9; P.33.35.121 a-c.)
- U.18722 Clay pot, Type JN.121 but with two spouts; of drab clay with decoration in red paint on the shoulder; ht. 0.275 m. Pit W, from the Jamdat Nasr grave stratum. Pl. 25. (L.BM.124456.)
- U.18729 Cylinder seal, steatite, Vol. X, No. 105. Pit X, in the stratum of the Sargonid graves. (B.18944.)
- U.18741 Ear-stud, dark greenish-grey stone (jasper), Type as Pl. 15, U.16603; ht. 0.014 m., diam. 0.025 m. Loose in the upper soil of Pit X.
- U.18758 Amulet, shell, in the form of a seated cow; pierced longitudinally. Ht. 0.014 m., l. 0.02 m. Brought in. Pl. 27. (L.BM.123589.)
- U.18830 Stamp seal, steatite, Vol. X, No. 103. Pit X, Level 15.00 m. (L.BM.123588.)
- U.18836 Beads; small natural shells pierced for stringing, carnelian rings and cylinders, marble diamond, steatite discoid, a chert date-shaped and double conoid, a white frit frog amulet: poor quality. PJ/G.17. (B.20376.)
- U.18846 Gold ear-ring, small lunate type, very thin metal of pale colour (electrum); diam. 0.015 m. Loose in the soil, Pit X, level 14.60 m. (B.20286.)
- U.18848 Stone bowl, grey steatite, fragment of; decorated with a grape-cluster (?) carved in relief; 0.03 m. x 0.02 m. Pit X, level 14.80 m. (B.20082.)
- U.18849 Cylinder seal, steatite, Vol. X, No. 470. Pit X, level 15.00 m. (B.18921.)
- U.18850 Gaming die of grey pottery; a cube 0.018 m. with the numbers on each side marked by pin-pricks made in the wet clay. Pit X, level 14.00-15.00. Fig. 7,b.
- U.18851 Amulet of blue-glazed frit; Im-dugud; 0.028 m. x 0.022 m. The glaze has perished on the front but is well preserved behind. Pit X, level 14.00-15.00 m. (P.35.1.31.)
- U.18860 Pottery fragment, from the rim of a bowl; fine dark grey ware, burnished, with an incised decoration of lines and concentric circles, the incisions filled with white paste. Pit X, level 15.00 m., loose in the soil. Fig. 18,a.
- U.18862 Bead, half of, flattened date-shape, of carnelian artificially bleached all over (the bleaching has penetrated deep into the stone) and then etched with a pattern in black. Pit X, about level 14.00 m. Pl. 28. (L.BM.123590.)
- U.18880 Beads; gold double conoids (poor, of thin metal), carnelian double conoids, rings, diamonds, agate tubular and date-shaped, lapis date-shaped, one pear-shaped carnelian with bleached pattern. PJ/G.57. Pl. 28. (P.35.1.77.)
- U.18881 Gold ear-rings, small lunate type, diam. 0.016 m. PJ/G.57. (B.20292.)
- U.18882 Cylinder seal, crystal, Vol. X, No. 289. Pit X, level 13.00 m. (B.18923.)
- U.18883 Cylinder seal, steatite, Vol. X, No. 561. Pit X, level 13.00 m. (L.BM.123583.)
- U.18884 Cylinder seal, steatite, Vol. X, No. 354. Pit X, at level 13.00 m. (B.18946.)
- U.18887 Beads; 2 nasturtium-seed beads and five 4<sup>flanged</sup> beads of gold, 6 carnelian date-shaped, 4 lapis-lazuli date-shaped and 1 lapis-lazuli cylinder. PJ/G.65.a. (L.BM.123594.)
- U.18888 Gold ear-ring, small lunate type, diam. 0.014 m. PJ/G.64. (B.20290.)
- U.18889 Cylinder seal, steatite, Vol. X, No. 353. Pit X, at level 12.50 m. (B.18952.)
- U.18890 Handle of twisted copper wire; a single strand of what seems to be drawn wire twisted on itself; l. 0.045 m. Pit X, found inside a clay vessel in a plundered grave at level 12.50 m. (B.20076.)
- U.18891 Gold finger-ring, a hoop of flat metal with the edges bent over to give the effect of a double hoop of wire; a pair of gold ear-rings, small lunate type, diam. 0.012 m.; fragments of narrow gold ribbon spirally twisted; a few beads, small carnelian date-shaped and paste balls plated with

- thin gold leaf. PJ/G.60 (B.20047.)
- U.18896 Cylinder seal, steatite, Vol. X, No 297. PJ/G.63. (B.18939.)
- U.18898 Cylinder seal, steatite, Vol. X, No. 160. PJ/G.85. (L.BM.123579.)
- U.18899 Cylinder seal, steatite, Vol. X, No. 281. PJ/G.90. (B.18949.)
- U.18900 Beads; small gold-cased copper balls, carnelian balls, lapis-lazuli triangles, date-shaped and tubular, large limestone balls and chalcedony flattened date-shaped. PJ/G.90. (B.20042.)
- U.18901 Beads; 3 large crystal flattened date-shaped, 1 limestone ditto, 1 agate barrel, 3 steatite rings. PJ/G.84. (L.BM.)
- U.18902 Cylinder seal, steatite, Vol. X, No. 44. Pit X, at level 12.00 m. (B.18943.)
- U.18913 Cylinder seal, steatite, Vol. X, No. 352. Pit X, at level 11.50 m. (B.18919.)
- U.18914 Cylinder seal, lapis lazuli, Vol. X, No. 130. PJ/G.107. (P.35.1.6.)
- U.18915 Cylinder seal, crystal, Vol. X, No. 45. PJ/G.108. (L.BM.123586.)
- U.18916 Cylinder seal, steatite, Vol. X, No. 307. PJ/G.98. (L.BM.123581.)
- U.18917 Cylinder seal, lapis lazuli, Vol. X, No. 139. PJ/G.101. (B.18918.)
- U.18918 Cylinder seal, steatite, carinated type, Vol. X, No. 186, inscribed 'The cup-bearer (?)' qu-šu-dug 'of Lu-d. KA-DI' PJ/G.101. (B.18875.)
- U.18919 Cylinder seal, steatite, Vol. X, No. 244, inscribed Ur-mah-gim. PJ/G.104. (P.35.1.22.)
- U.18920 Cylinder seal, steatite, Vol. X, No. 238. PJ/G.109. (B.18927.)
- U.18921 Cylinder seal, steatite, Vol. X, No. 179. PJ/G.99. (B.18922.)
- U.18922 Cylinder seal, steatite, Vol. X, No. 92 inscribed Ur-gis-me-e. PJ/G.99. (P.35.1.16.)
- U.18923 Cylinder seal, shell, Vol. X, No. 135. V. PJ/G.99. (P.35.1.2.)
- U.18924 Cylinder seal, steatite, Vol. X, No. 183. PJ/G.94. (P.35.1.17.)
- U.18925 Cylinder seal, steatite, Vol. X, No. 176. PJ/G.91. (P.35.1.8.)
- U.18926 Cylinder seal, steatite, Vol. X, No. 131. PJ/G.100. (B.18924.)
- U.18927 Cylinder seal, steatite, Vol. X, No. 288. PJ/G.106. (P.35.1.10.)
- U.18928 Stamp seal, steatite, Vol. X, No. 633. PJ/G.103. (B.18954.)
- U.18929 Beads; carnelian date-shaped and cylindrical, one of the latter with a bleached spiral line, and rings; lapis-lazuli double conoids, paste ditto, steatite tubular, steatite chisel pendant, and frog amulet, a quartzite flat truncated date-shaped bead. Also two hair-rings each of 5 coils of thin gold wire. PJ/G.107. (B.20303.)
- U.18930 Group. Gold hair-ribbon, l. 0.20 m., width 0.007 m., with hole at each end, spirally twisted: 2 gold ear-rings, small lunate type, intertwined with similar rings in copper: a copper finger (?) -ring of spirally coiled wire: 2 plain copper toe-rings: copper reticule: copper bowl, Type RC.3, ht. 0.05 m., diam. 0.10 m.: beads, gold diamonds, balls and ribbed balls, carnelian tube 0.09 m. long, large flat agate oval, carnelian double conoids, lapis-lazuli double conoids and tubes, gate date-shaped, silver balls. PJ/G.94. (B.20131, 20250-1, 20295-6.)
- U.18931 Gold ear-rings, small lunate type, diam. 0.013 m., a pair; also beads, carnelian rings and date-shaped, crystal date-shaped, chalcedony date-shaped, agate barrel, 2 gold-plated copper balls. PJ/G.102. (B.20280.)
- U.18932 Beads; large steatite barrel, carnelian double conoids, date-shaped and balls, agate barrels and date-shaped, crystal date-shaped, long carnelian tube, steatite date-shaped engraved with criss-cross lines, paste rings. Re-strung in original order. PJ/G.106. (B.20335.)
- U.18933 Beads; carnelian cylinders and ring, lapis-lazuli diamonds and cylinders. PJ/G.108. (L.BM.)
- U.18942 Beads; carnelian tubular and rings, paste date-shaped, steatite fluted balls, fly and frog amulets. PJ/G.95. (B.20331.)
- U.18943 Group. One gold ear-ring, small lunate type; silver finger-ring, plain wire hoop; silver hair-ring, 2 coils of spirally coiled plain wire; gold hair ribbon, l. 0.08 m., width 0.01 m., with hole at each end, spirally twisted; copper pin, Type RC.8, l. 0.105 m.; copper reticule; beads, lapis-lazuli diamonds and tubes, silver diamonds and tubes, small blue glazed cylinders. PJ/G.101. (B.20316, 20368-9.)
- U.18944 Gold ear-ring, made of two small lunate rings intertwined. PJ/G.93. (L.BM.)
- U.18945 Stone bowl, white calcite, Type RC.54, diam. 0.105 m. Broken and rivetted in antiquity. PJ/G.105. (B.19834.)
- U.18946 Cylinder seal, steatite, Vol. X, No. 157. PJ/G.111. (P.35.1.4.)
- U.18947 Cylinder seal, steatite, Vol. X, No. 111. PJ/G.115. (P.35.1.11.)
- U.18948 Cylinder seal, steatite, Vol. X, No. 507, inscribed 'Ilu-ši (?) -ir, son of Dudu.' PJ/G.123. (P.35.1.13.)
- U.18949 Cylinder seal, steatite, Vol. X, No. 298, inscribed 'Ur. . . son of Ur-Nanna-pad-da.' PJ/G.123. (B.18925.)
- U.18950 Gold ear-ring, made of two rings of the small lunate type, one solid and one hollow, interlaced. PJ/G.120. (B.20293.)

- U.18951 Cylinder seal, lapis-lazuli, Vol. X, No. 88. PJ/G.113. (B.18929.)
- U.18952 Stone bowl, white limestone, Type RC.16b.; ht. 0.05 m., diam. 0.12 m. PJ/G.113. (B.19853.)
- U.18953 Beads; large carnelian and lapis-lazuli date-shaped, carnelian double conoid, rings and barrel, small lapis-lazuli cylinders and 1 agate date-shaped. Re-strung in original order. PJ/G.113. (B.20336.)
- U.18954 Beads; small gold ribbed balls, carnelian balls, one paste flattened date-shape. PJ/G.122. (B.20284.)
- U.18955 Stone bowl, basic diorite, Type RC.36, ht. 0.08 m., diam. 0.135 m.; chipped. PJ/G.97. (B.30885.)
- U.18956 Stone vase, white calcite, Type RC.80, ht. 0.15 m., diam. 0.115 m. PJ/G.118. (L.)
- U.18957 Stone vase, white calcite, Type RC.80, ht. 0.11 m., diam. 0.07 m. PJ/G.121. (L.)
- U.18958 Beads; small paste cylinders, carnelian double conoids, barrels, diamonds and date-shaped (one with bleached pattern) lapis-lazuli double conoids and balls, quartzite rhomboid, large. Re-strung in original order. PJ/G.121. (L.BM.123598.)
- U.18959 Stone vase, white calcite, Type RC.78, ht. 0.105 m. Roughly made; most of rim missing. PJ/G.121. (B.19871.)
- U.18960 Beads; small gold balls, small silver balls (mostly decayed), small carnelian balls, lapis-lazuli diamonds, crystal ring beads, paste balls; re-strung in original order. Also a gold ear-ring, small lunate type, originally intertwined with a similar ring in silver. PJ/G.119. (B.20278-9.)
- U.18962 Beads; lapis-lazuli diamonds, carnelian rings and tubes, steatite cylinder and diamond. PJ/G.115. (B.20334.)
- U.18963 Gold ear-ring, small lunate type, diam. 0.014 m. Loose in soil of Pit X, level 10.00-11.00 m. (B.20285.)
- U.18964 Cylinder seal, steatite, Vol. X, No. 293, inscribed 'Ur-ŠEŠ-GIR, son of Ur-guenna' Pit X, at Level 11.00 m. (B.18926.)
- U.18965 Beads; small gold balls and ribbed balls, small carnelian balls, 2 carnelian date-shaped, 2 tubular and one flattened oval with bleached pattern, one lapis-lazuli ball; also a gold ear-ring, small lunate type. PJ/G.125. (B.20282-3.)
- U.18971 Gold ear-ring, small lunate type, intertwined with a similar ring of copper. PJ/G.87. (B.20288.)
- U.18972 Cylinder seal, steatite, Vol. X, No. 294. Pit X, at level 10.00 m. (L.BM.123571.)
- U.18973 Cylinder seal, steatite, Vol. X, No. 237. PJ/G.140. (L.BM.)
- U.18974 Cylinder seal, steatite, Vol. X, No. 295, inscribed 'Lugal-ma'. PJ/G.140. (P.35.1.9.)
- U.18975 Cylinder seal, lapis-lazuli, Vol. X, No. 228. PJ/G.141. (B.18936.)
- U.18976 Cylinder seal, light yellow stone, Vol. X, No. 95. PJ/G.143. (P.35.1.5.)
- U.18977 Cylinder seal, steatite, Vol. X, No. 296. Pit X, at level 10.00 m. (B.18920.)
- U.18978 Cylinder seal, steatite, Vol. X, No. 294. PJ/G.136. (B.18933.)
- U.18979 Cylinder seal, steatite, Vol. X, No. 166. PJ/G.136.
- U.18980 Cylinder seal, shell, Vol. X, No. 62. Pit X, at level 9.00 m.-10.00 m. (B.18941.)
- U.18981 Cylinder seal, green stone, Vol. X, No. 187. PJ/G.142. (P.)
- U.18982 Cylinder seal, lapis-lazuli, Vol. X, No. 165, inscribed 'A-tud nu-banda'. PJ/G.139. (B.18938.)
- U.18983 Cylinder seal, lapis-lazuli, Vol. X, No. 125. Pit X, at level 9.00 m.-10.00 m. (L.BM.123570.)
- U.18984 Cylinder seal, steatite, l. 0.027 m., much worn; hunters and animals. PJ/G.135. (B.18931.)
- U.18985 Cylinder seal, steatite, Vol. X, No. 239. Pit X, at level 10.00 m. (B.18940.)
- U.18986 Cylinder seal, lapis-lazuli, Vol. X, No. 129. Pit X, at level 10.00 m. (B.18930.)
- U.18987 Cylinder seal, shell, Vol. X, No. 188. Pit X, at level 10.00 m. (B.18983.)
- U.18990 Beads; one very long carnelian tubular, carnelian rings and date-shaped, lapis-lazuli balls, chalcedony barrel and crystal ring. PJ/B.6. (L.BM.)
- U.18991 Stone mortar, coarse white limestone, Type RC.37a, ht. 0.08 m., diam. 0.145 m. PJ/B.6. (B.20598.)
- U.18992 Stone bowl, white calcite, Type RC.109, ht. 0.04 m., diam. 0.11 m. PJ/B.8. (B.20552.)
- U.18993 Stone vase, white calcite, Type RC.5, ht. 0.135 m., diam. 0.105 m. From a ruined grave just below the Sargonid level in Pit X, (level 10.00 m.) (L.)
- U.18994 Cylinder seal, lapis-lazuli, Vol. X, No. 200. PJ/G.148. (P.35.1.14.)
- U.18995 Beads; large chalcedony date-shaped, chalcedony balls, granite flattened date-shaped, limestone ditto, agate and crystal ditto, carnelian, chalcedony and silver balls. PJ/G.148. (B.20329.)
- U.18996 Beads; very small glazed frit rings, 2 steatite frog amulets, carnelian tube with bleached pattern, PJ/B.5. (B.20056.)
- U.18997 Beads; large lapis-lazuli double conoids, chalcedony flattened oval, crystal rings. PJ/G.131. (B.20051.)
- U.18999 Cylinder seal, steatite, l. 0.041 m.; eagle grasping two gazelles. PJ/B.3. (B.18988.)
- U.19000 Cylinder seal, lapis-lazuli, Vol. X, No. 182. PJ/G.149. (L.BM.123580.)
- U.19001 Cylinder seal, steatite, Vol. X, No. 327. Pit X, at level 10.00 m.-11.00 m. (B.18884.)

- U.19002 Cylinder seal, steatite, Vol. X, No. 291. Pit X, at level 10.00 m. -11.00 m. (B.18887.)
- U.19003 Cylinder seal, glazed frit, Vol. X, No. 552. Pit X, at level 10.00 m. -11.00 m. (B.18878.)
- U.19004 Cylinder seal, steatite, Vol. X, No. 143. PJ/G.133. (B.18890.)
- U.19005 Cylinder seal, lapis-lazuli, Vol. X, No. 156. PJ/G.145. (B.18879.)
- U.19006 Cylinder seal, steatite, Vol. X, No. 305. Pit X, at level 10.00 m. -11.00 m. (L.BM.123578.)
- U.19008 Cylinder seal, steatite, Vol. X, No. 304. PJ/G.128. (B.18869.)
- U.19009 Stone vase, white calcite, Type RC.92, ht. 0.16 m., diam. 0.062 m. PJ/B.2. (B.20588.)
- U.19010 Stone vase, white calcite, Type RC.92, ht. 0.16 m., diam. 0.075 m. PJ/B.3. (B.19990.)
- U.19011 Stone bowl, white calcite, Type RC.54, ht. 0.04 m., diam. 0.11 m. PJ/B.3. (P.35.1.191.)
- U.19012 Beads; lapis-lazuli double conoids, graded in sizes. PJ/B.3. (P.35.1.97.)
- U.19014 Beads; lapis-lazuli, small tubes and balls and one rectangular with convex sides. PJ/B.2. (B.20317.)
- U.19015 Stone vase, white calcite, Type RC.5, ht. 0.105 m., diam. 0.07 m. Pit X, from a plundered grave. (P.35.1.199.)
- U.19016 Stone bowl, grey limestone, Type RC.16a, ht. 0.05 m., diam. 0.135 m. PJ/B.2. (B.20559.)
- U.19017 Stone bowl, white calcite, Type RC.54, ht. 0.06 m., diam. 0.155 m. PJ/B.14. (B.30707.)
- U.19018 Group; a pair of gold ear-rings, small lunate type; beads, carnelian tubes, square tubes, barrels and rectangular, gold balls, lapis-lazuli date-shaped, large chalcedony flattened oval; gold hair-ribbon; copper bracelet, plain; copper bowl, Type RC.3, ht. 0.04 m., diam. 0.10 m. PJ/G.139. (B.20043, 20129-30, 20298.)
- U.19020 Copper object, perhaps a handle, or a rivet; l. 0.10 m. PJ/B.12. Pl. 29. (B.20219.)
- U.19021 Beads; agate flattened oval, lapis-lazuli tubes and double conoids, crystal balls, carnelian date-shaped and one ball with bleached pattern of concentric circles. PJ/G.133. Pl. 28. (L.BM.)
- U.19022 Gold frontlet, Type RC.1, l. 0.11 m.; gold frontlet, Type RC.2, with pierced ends, l. 0.085 m.; beads, very long carnelian tubes, carnelian balls, crystal balls, lapis-lazuli tubes and double conoids, silver balls, balls of copper plated with gold leaf, one carnelian flattened disk. PJ/G.146. (P.35.1.100.)
- U.19023 Stone bowl, white limestone, Type RC.107, l. 0.21 m., width 0.13 m., ht. 0.065 m. PJ/B.12. (B.20246.)
- U.19024 Stone bowl, white limestone, Type RC.41, ht. 0.065 m., diam. 0.145 m. PJ/B.16. (B.30735.)
- U.19026 Beads; one gold double conoid, 2 lapis-lazuli ditto, 2 carnelian barrels, small paste double conoids, paste and lapis-lazuli rings. PJ/G.135. (P.35.1.99.)
- U.19027 Beads; lapis-lazuli double conoids and ovals, carnelian rings and one large lapis-lazuli date-shaped. PJ/B.19. (B.19822, 20311.)
- U.19028 Beads; small paste lentoids. Pit X, from a plundered Sargonid grave. (B.20327.)
- U.19030 Beads; carnelian tubes and date-shaped, lapis double conoid, small carnelian rings, paste balls and some silver beads, decayed. PJ/B.26. (L.BM.)
- U.19031 Cylinder seal, shell, Vol. X, No. 173. PJ/G.156. (B.18886.)
- U.19032 Cylinder seal, shell, Vol. X, No. 172. PJ/G.159. (B.18880.)
- U.19033 Cylinder seal, steatite, Vol. X, No. 231. PJ/G.152. (B.18872.)
- U.19034 Cylinder seal, steatite, Vol. X, No. 181. Pit X, from a plundered Sargonid grave. (L.BM.123582.)
- U.19035 Beads; small lapis-lazuli barrels, balls and double conoids, carnelian rings, barrels and tubes, two of the last with bleached patterns of concentric circles. Pit X, from a plundered Sargonid grave. (B.20062.)
- U.19036 Copper goblet, Type RC.117, ht. 0.08 m., rim diam. 0.095 m. cracked and with a small piece missing. PJ/G.157. (B.20156.)
- U.19037 Statue, of white calcite, ht. 0.255 m. The figure of a woman carved in the round, standing with hands clasped below the breast and wearing the kaunakes garment. The figure is made from two pieces of stone morticed together at the waist; the stone seems to have been a fairly thin slab, the back of which is virtually the back of the statue; this is practically flat and the back of the head which should project behind the general plane is missing and was made separately (perhaps of plaster). The eyes are inlaid with shell and lapis-lazuli and a strip of lapis-lazuli forms the fillet across the forehead and down each side of the face; some of this is missing; the eyebrows, cut as grooves, were inlaid with black paste which came away in powder with the earth; there was black paint on the hair and between the tufts of the *kaunakes*.
- The stone is decayed in places and has risen in blisters which interfere with the modeling of the right side of the face, right arm and hair; the left side is stained green by the axe against which it lay. PJ/B.36. Pl. 37. and v. p. 37. (B.19822.)
- U.19038 Conch shell, cut open to serve as a lamp; at the top of the opening is engraved a bird's head with the eye inlaid with lapis-lazuli. L. 0.19 m. PJ/B.20. Cf. Vol. II, Pl. 101. (B.20011.)
- U.19039 Beads; carnelian cylinders and one double conoid, ball and rings, paste tube and balls, silver

- balls. PJ/G.153. (B.20352.)
- U.19040 Cylinder seal, shell, Vol. X, No. 142. PJ/B.30. (B.18865.)
- U.19041 Stone bowl, white limestone, Type RC.42, ht. 0.06 m., diam. 0.09 m. PJ/B.20.
- U.19042 Stone bowl, white calcite, ht. 0.029 m., diam. 0.085 m. PJ/G.155. (B.19833.)
- U.19044 Beads; carnelian date-shaped (4) and very small rings and tubes of lapis and paste. PJ/B.13. (B.20358.)
- U.19045 Cylinder seal, shell, l. 0.014 m., diam. 0.008 m. Two gazelles. PJ/B.13. (B.18917.)
- U.19047 Beads; carnelian large date-shaped and rings, steatite barrel, agate tube, small paste tubes and date-shaped, and 3 steatite frog amulets. PJ/G.145. Pl. 28. (P.35.1.92.)
- U.19048 Stone bowl, basic diorite, Type RC.51, ht. 0.11 m., diam. 0.19 m. Pit X, from a plundered PJ/B grave. (L.)
- U.19049 Stone vase, white calcite, Type RC.61a, ht. 0.115 m., diam. 0.075 m. PJ/B.27. (L.)
- U.19050 Stone vase, white limestone, Type RC.80, ht. 0.145 m., diam. 0.105 m. PJ/B.26. (P.35.1.524.)
- U.19051 Beads; 3 carnelian barrels, one with bleached decoration, lapis tubes and small balls or barrels, small rings of glazed frit and 3 lapis frog amulets. Pit X, from a plundered PJ/B grave. Pl. 28. (P.)
- U.19053 Beads; a set of lapis-lazuli triangular spacers from a "dog-collar," the corresponding silver spacers decayed; also a string of carnelian, lapis-lazuli and silver balls, tubes and rings. PJ/B.33. (L.BM.)
- U.19054 Beads; carnelian rings and truncated triangles, and one diamond, lapis-lazuli diamonds and balls, paste long date-shaped. PJ/B.29. (B.20048.)
- U.19055 Beads; carnelian rings, cylinders, balls and double conoids, lapis-lazuli balls, ovals and double conoids, paste ribbed balls, steatite frog amulet and mother-of-pearl bird amulet. PJ/B.49. (B.20057-9.)
- U.19056 Beads; carnelian balls, long date-shaped and cylindrical, lapis-lazuli ovals and cylinders, shell date-shaped, jasper and paste date-shaped and paste rings, steatite frog amulets. PJ/B.40. (B.20360.)
- U.19057 Cylinder seal, shell, Vol. X, No. 140. Pit X, from a plundered PJ/B grave. (L.BM.123568.)
- U.19058 Stone vase, white calcite, Type RC.92, ht. 0.22 m., diam. 0.08 m. PJ/B.33. (L.)
- U.19059 Stone vase, white calcite, Type RC.4, ht. 0.15 m., diam. 0.105 m. PJ/B.38. (B.19982.)
- U.19060 Stone vase, white calcite, Type RC.62, ht. 0.10 m., diam. 0.06 m. PJ/B.32. (P.35.1.198.)
- U.19061 Stone bowl, white limestone, Type RC.43, ht. 0.55 m., diam. 0.85 m. Pit X, from a plundered PJ/B grave. Pl. 34. (B.19867.)
- U.19062 Stone vase, white calcite, Type RC.60b, ht. 0.11 m., diam. 0.065 m. PJ/B.30. (L.)
- U.19063 Stone vase, white calcite, Type RC.60b, ht. 0.10 m., diam. 0.05 m. PJ/B.29. (B.19838.)
- U.19064 Stone vase, white calcite, Type RC.3, ht. 0.17 m., diam. 0.125 m. PJ/G.159. (L.)
- U.19065 Stone vase, white calcite, Type RC.65, variant, more slender and with rounded base; ht. 0.145 m., diam. 0.065 m. Pit X, from a plundered PJ/B grave. (P.)
- U.19066 Stone vase, white calcite, Type RC.115, ht. 0.155 m., diam. 0.075 m. Pit X, from a plundered PJ/B grave. (B.19980.)
- U.19067 Stone vase, white calcite, Type RC.1, ht. 0.16 m., diam. 0.13 m. PJ/B.18. (B.19888.)
- U.19068 Stone tumbler, limestone, Type RC.13, ht. 0.105 m. Pit X, from a plundered PJ/B grave. Pl. 34. (L.)
- U.19070 Stone bowl, basic diorite, Type RC.20b; ht. 0.033 m. Pit X, from a plundered PJ/B grave. (B.20560.)
- U.19071 Cylinder seal, shell, Vol. X, No. 79. PJ/B.42. (B.18901.)
- U.19072 Cylinder seal, lapis-lazuli, Vol. X, No. 120. PJ/B.28. (B.18910.)
- U.19073 Beads; lapis-lazuli, two large date-shaped and a number of small balls. PJ/B.41. (L.BM.)
- U.19074 Beads; lapis-lazuli small balls, ovals and double conoids, carnelian and silver balls. PJ/B.32. (B.20322.)
- U.19075 Cylinder seal, lapis-lazuli, Vol. X, No. 80. PJ/B.38. (P.35.1.7.)
- U.19076 Beads; carnelian rings, tubes and date-shaped, lapis-lazuli double conoids, barrels and tubes, paste date-shaped and small rings, 2 lapis frog amulets. PJ/B.38. (B.20306.)
- U.19077 Beads; one long carnelian date-shaped, many small ditto of dark steatite. Pit X, from a plundered PJ/B grave. (B.20330.)
- U.19078 Gold ear-ring, a heavy loop, slightly lunate, with overlapping ends; diam. 0.025 m. PJ/B.35. (B.20294.)
- U.19080 Cylinder seal, shell, Vol. X, No. 63, Pit X, from a plundered PJ/B grave. (B.18871.)
- U.19081 Cylinder seal, shell, Vol. X, No. 138. Pit X, from a plundered PJ/B grave. (L.BM.123574.)
- U.19082 Stone bowl, dark steatite, Type RC.41, ht. 0.08 m., diam. 0.15 m. Broken and rivetted in antiquity. PJ/B.38. (B.20602.)

- U.19083 Stone bowl, basic diorite, Type RC.19a, ht. 0.065 m., diam. 0.165 m. PJ/B.33. (B.19944.)
- U.19084 Stone bowl, diorite, Type RC.16b, ht. 0.085 m., diam. 0.16 m. Pit X, from a plundered PJ/B grave. (B.30760.)
- U.19085 Stone bowl, fragment of, dark greenish steatite; the surface covered with a pattern carved in relief, very fine work. Orig. ht. 0.06 m., diam. 0.12 m. Pit X, in the stratum of the graves of the PJ/B series. Pl. 35. (B.19839.)
- U.19086 Gaming-board, fragments from: 7 shell squares 0.02 m. sq., engraved with curved lines in each corner producing the effect of a cross, and a central dot; these were inlaid, framed by narrow strips of brown wood (?); also 5 shale disks each inlaid with 5 white dots and one, two or three smaller red dots; and 2 shale squares each inlaid with 5 white dots; the shell pieces are inlay from the board, the shape pieces probably the "men." PJ/B.34. (B.20378.)
- U.19087 Stone bowl, rough white limestone, Type RC.102, ht. 0.065 m., diam. 0.195 m. x 0.15 m. Pit X, from a plundered PJ/B grave. (P.35.1.523.)
- U.19088 Stone bowl, white limestone, Type RC.48, ht. 0.04 m., diam. 0.105 m. PJ/B.41.
- U.19089 Conch shell cut as a lamp with a bird's head engraved at the top of the opening; cf. U.19038, and Vol. II, Pl. 101, a. PJ/B.41. (B.20012.)
- U.19091 Conch shell cut as a lamp, like U.19089. Pit X, from a plundered PJ/B grave. (P.35.1.63.)
- U.19092 Stone bowl, diorite, Type RC.41, ht. 0.08 m., diam. 0.175 m. Pit X, from a plundered PJ/B grave.
- U.19093 Beads; carnelian rings, steatite tubes, lapis-lazuli tubes, rings and ovals, PJ/B.50. (B.20054.)
- U.19094 Beads; carnelian balls and lapis double conoids. Pit X, from a plundered PJ/B grave. (B.20055.)
- U.19095 Stone bowl, diorite, Type RC.16b, ht. 0.07 m., diam. 0.17 m. PJ/B.27. (L.)
- U.19096 Stone vase, white limestone, Type RC.17, ht. 0.10 m., diam. 0.06 m. Pit X, from a plundered PJ/B grave. (B.19993.)
- U.19097 Stone bowl, diorite, Type RC.36, ht. 0.065 m., diam. 0.20 m. Pit X, from a plundered PJ/B grave. (L.)
- U.19098 Cylinder seal, lapis-lazuli, l. 0.028 m., diam. 0.08 m. Rough geometrical design. PJ/B.46. (B.18909.)
- U.19099 Beads; small paste date-shaped. PJ/B.46. (B.20359.)
- U.19100 Copper pin, the head in the form of a woman's head with elaborately dressed hair; the point missing. L. 0.16 m. PJ/B.46. Pl. 29. (B.20379.)
- U.19101 Copper pin, upper part of, having near the head the figure of a seated calf, moulded in the round, attached to the stem. Found with U.19102 in Pit X, in a plundered PJ/B grave. Pl. 29. (B.20380.)
- U.19102 Copper pin, upper part of, with head in the form of a horned head of god or demon. Found with U.19101. Pit X. Pl. 29. (P.35.1.479.)
- U.19103 Beads; minute rings of blue glaze. Pit X, from a plundered PJ/B grave. (B.20066.)
- U.19104 Cylinder seal, shell, Vol. X, No. 171. PJ/B.50. (B.18945.)
- U.19105 Stone vase, white calcite, Type RC.79, ht. 0.12 m., diam. 0.085 m. Pit X, from a plundered PJ/B grave. (B.19988.)
- U.19107 Stone bowl, white limestone, Type RC.47, ht. 0.04 m., diam. 0.08 m. PJ/B.57. (B.19832.)
- U.19108 Stone vase, white calcite, Type RC.4, ht. 0.075 m., diam. 0.065 m. Pit X, from a plundered PJ/B grave. Pl. 34. (B.19986.)
- U.19109 Stone vase, white calcite, Type RC.87, ht. 0.13 m., diam. 0.165 m. Pit X, from a plundered PJ/B grave. (L.)
- U.19110 Stone vase, white calcite, Type RC.67, ht. 0.07 m., diam. 0.07 m. Pit X, from a plundered PJ/B grave. (B.30706.)
- U.19111 Stone bowl, white limestone, Type RC.22a, ht. 0.05 m., diam. 0.20 m. Pit X, from a plundered PJ/B grave. (L.)
- U.19112 Stone bowl, basic diorite, Type RC.114, ht. 0.09 m., diam. 0.085 m. Pit X, from a plundered PJ/B grave. (B.19940.)
- U.19113 Stone bowl, white limestone, Type RC.22a, ht. 0.045 m., diam. 0.135 m. Pit X, from a plundered PJ/B grave. (B.20587.)
- U.19114 Stone bowl, basic diorite, Type RC.22a, ht. 0.04 m., diam. 0.10 m. Pit X, from a plundered PJ/B grave. (B.20586.)
- U.19115 Stone bowl, basic diorite, Type RC.19a, ht. 0.055 m., diam. 0.09 m. Pit X, from a plundered PJ/B grave. (L.)
- U.19116 Beads; lapis-lazuli and paste double conoids. PJ/B.58. (B.20071-5.)
- U.19117 Stone bowl, basic diorite, Type RC.22b, ht. 0.035 m., diam. 0.095 m. PJ/B.58. (B.20551.)
- U.19118 Cylinder seal, green stone, Vol. X, No. 242. Pit X, in the Sargonid grave stratum. (B.18868.)
- U.19119 Cylinder seal, lapis-lazuli, Vol. X, No. 119. Pit X, from a plundered PJ/B grave. (B.18908.)
- U.19120 Cylinder seal, steatite, Vol. X, No. 162. Pit X, in the PJ/B stratum. (B.18912.)



- U.19121 Cylinder seal, steatite, Vol. X, No. 233. Pit X, from a plundered PJ/B grave. (L.BM.123576.)
- U.19122 Cylinder seal, crystal, Vol. X, No. 124. Pit X, from a plundered PJ/B grave. (B.18873.)
- U.19124 Cylinder seal, steatite, Vol. X, No. 177. Pit X, from a plundered PJ/B grave. (B.18900.)
- U.19125 Cylinder seal, lapis-lazuli, Vol. X, No. 53. Pit X, in the PJ/B grave stratum. (B.18906.)
- U.19126 Cylinder seal, steatite, Vol. X, No. 328, inscribed 'Ninmar-ka-išag, son of Mukabbur.' Pit X. (L.BM.123584.)
- U.19127 Beads; carnelian rings and balls and very small glaze balls and tubes. PJ/B.44. (P.35.1.73.)
- U.19129 Spindle-whorl, shell, diam. 0.022 m., with engraved pattern; Pl. 16. Pit X, from a plundered PJ/B grave. (B.20080.)
- U.19130 Cylinder seal, calcite, Vol. X, No. 52. PJ/B.56. (B.18892.)
- U.19131 Beads; 3 carnelian long date-shaped, 1 faceted date-shaped; lapis-lazuli small balls, large double conoids, striated ball and phallic pendant. PJ/B.54. (L.)
- U.19132 Cylinder seal, lapis-lazuli, Vol. X, No. 51. Pit X, from a plundered PJ/B grave. (B.18911.)
- U.19134 Copper cauldron with spout and stand; ht. 0.35 m., diam. 0.33 m. Inside it is a copper bowl of Type RC.3 (?). PJ/G.163. Pl. 29. (B.23462-3.)
- U.19135 Stone vase, white calcite, Type RC.106, ht. 0.15 m., diam. 0.09 m. Pit X, from a plundered PJ/B grave. (P.)
- U.19136 Stone bowl, white limestone, Type RC.47, ht. 0.04 m., diam. 0.09 m. PJ/B.27. (B.19881.)
- U.19137 Stone bowl, grey limestone, Type RC.20a, ht. 0.05 m., diam. 0.15 m. Pit X, from a plundered PJ/B grave. (B.)
- U.19138 Stone bowl, white limestone, Type RC.16b, ht. 0.075 m., diam. 0.15 m.; on the side is roughly engraved a large pentagram or 'Solomon's Seal.' Pit X, from a plundered PJ/B grave. (B.19947.)
- U.19162 Table of offerings, white limestone, Type RC.101, fragmentary; the stem is roughly engraved with chevron and palm-leaf patterns. Pit X, from a plundered PJ/B grave.
- U.19168 Stone vase, veined calcite, Type RC.89, ht. 0.13 m., diam. 0.09 m. PJ/B.74. (B.19984.)
- U.19169 Stone bowl, white calcite, Type RC.66, ht. 0.08 m., diam. 0.12 m. PJ/B.73. (B.19825.)
- U.19170 Stone vase, white calcite, Type RC.76, ht. 0.125 m., diam. 0.09 m. PJ/B.73. (B.19826.)
- U.19171 Stone vase, white calcite, Type RC.60b, ht. 0.12 m., diam. 0.06 m. PJ/B.72. (P.35.1.195.)
- U.19172 Stone vase, white limestone, Type RC.89, ht. 0.11 m., diam. 0.06 m. PJ/B.74. (B.19828.)
- U.19173 Stone bowl, basic diorite, Type RC.24, ht. 0.05 m., diam. 0.15 m. Along the flat rim is a pattern of chevrons and dots, lightly engraved. PJ/B.49. (B.19935.)
- U.19175 Stone bowl, fine white limestone, Type RC.15a, ht. 0.08 m., diam. 0.185 m. PJ/B.68. (B.19967.)
- U.19176 Stone bowl, basic diorite, Type RC.16a, ht. 0.068 m., diam. 0.012 m. PJ/B.72. (B.19851.)
- U.19177 Stone bowl, white limestone, Type RC.18, ht. 0.08 m., diam. 0.12 m. PJ/B.68. (B.20555.)
- U.19178 Stone vase, white calcite, Type RC.89, ht. 0.12 m., diam. 0.065 m. PJ/B.55. (B.19878.)
- U.19179 Stone bowl, basic diorite, Type RC.41, ht. 0.10 m., diam. 0.125 m. PJ/B.73. (B.20561.)
- U.19180 Beads; lapis-lazuli tubes, lapis-lazuli and carnelian rings and truncated triangles. Pit X, from a plundered PJ/B grave. (P.35.1.76.)
- U.19181 Beads; lapis-lazuli and carnelian double conoids, carnelian rings, lapis-lazuli ovals, large cat's eye and white calcite truncated triangle. PJ/B.74. (B.20060.)
- U.19182 Beads; carnelian rings and balls (one large), lapis-lazuli double conoids, ovals, tubes and (large) diamond. PJ/B.73. (B.20050.)
- U.19183 Beads; lapis-lazuli large double conoids, carnelian double conoids, date-shaped and long date-shaped. PJ/B.67. (L.BM.)
- U.19184 Beads; two long carnelian tubes and carnelian and lapis-lazuli date-shaped. PJ/B.68. (B.20067.)
- U.19185 Beads; carnelian date-shaped, lapis-lazuli date-shaped, double conoid, and (one) flattened cylinder. Pit X, from a plundered PJ/B grave. (P.35.1.75.)
- U.19186 *Group*; a pair of gold ear-rings each made of 3 hoops of spirally wound wire, diam. 0.027 m.; copper pin, Type RC.1, with ball head of steatite capped with gold; beads, gold fluted balls, small lapis-lazuli date-shaped with ring grooving, carnelian rings and one large flattened date-shaped. PJ/B.78. (B.20300-2.)
- U.19187 Stone vase, calcite, Type RC.61a; ht. 0.07 m. PJ/B.70. (B.19883.)
- U.19188 Cylinder seal, steatite, Vol. X, No. 336. Pit X, in the Sargonid grave stratum. (B.18885.)
- U.19189 Stone vase, white calcite, Type RC.65, ht. 0.095 m., diam. 0.085 m. Pit X, from a plundered PJ/B grave. (B.19875.)
- U.19190 Copper pin, Type RC.6, l. 0.24 m., with decorated head. PJ/B.64. Pl. 29. (L.BM.123566.)
- U.19192 Stone vase, white calcite, Type RC.86, ht. 0.14 m. Pit X, from a plundered grave of the PJ/B series. (B.19874.)
- U.19194 A pair of gold ear-rings, each made of 3 hoops of spirally wound wire, diam. 0.02 m.; also beads, carnelian rings, date-shaped and double conoid, a quartzite truncated triangle pendant, lapis-lazuli balls, double conoids, ribbed cylinder and small amulet in the form of a seated cow.

- PJ/B.80. (B.20313.)
- U.19195 Group; a pair of gold ear-rings, each made of 3 hoops of spirally wound wire; silver ear-rings, a pair, similar to the gold and unusually well preserved; beads, small lapis-lazuli balls and ovals, carnelian rings and silver balls. PJ/B.77.
- U.19196 Cylinder seal, calcite, Vol. X, No. 137. PJ/B.65.
- U.19197 Cylinder seal, shell, Vol. X, No. 93. Pit X, from a plundered PJ/B grave. (B.18877.)
- U.19200 Beads; lapis-lazuli small balls, ovals and date-shaped. PJ/B.83. (L.BM.)
- U.19201 Stone bowl, white limestone, Type RC.47, ht. 0.048 m., diam. 0.10 m. PJ/B.84. (P.35.1.187.)
- U.19202 Stone bowl, grey steatite, Type RC.37b, ht. 0.09 m., diam. 0.11 m. PJ/B.79. (B.19862.)
- U.19203 Beads; carnelian rings and one flattened rectangle, lapis-lazuli tubes, ovals and date-shaped and one flattened rectangle. They were strung in groups of about 8 of each material. PJ/B.84.
- U.19204 Stone vase, white calcite, Type RC.89, ht. 0.125 m., diam. 0.07 m. PJ/B.82. (B.19983.)
- U.19205 Cylinder seal, green calcite, Vol. X, No. 123. PJ/B.81. (B.18866.)
- U.19206 Copper pin, Type RC.1, with lapis ball head capped with gold. L. 0.12 m. PJ/B.81. (B.20277.)
- U.19208 Stone vase, white calcite, Type RC.61b, ht. 0.135 m., diam. 0.085 m. Pit X, from a plundered PJ/B grave. (B.20596.)
- U.19209 Cylinder seal, steatite, Vol. X, No. 550. Pit X, in the Sargonid grave stratum. (B.18874.)
- U.19211 Stone bowl, calcite, Type RC.40; ht. 0.035 m., diam. 0.053 m. The inside is black and it seems to have been used for kohl. Pit X, from a plundered PJ/B grave. (B.19840.)
- U.19212 Stone vase, white calcite, Type RC.110, ht. 0.15 m., diam. 0.08 m. Pit X, from a plundered PJ/B grave. (B.19827.)
- U.19213 Group. Beads; gold and lapis double conoids; copper pin, Type RC.1, with lapis ball head capped with gold, broken, l. 0.185 m.; white limestone bowl, Type RC.47, ht. 0.07 m., diam. 0.105 m.; white calcite bowl, Type RC.54, ht. 0.042 m. diam. 0.07 m. PJ/B.86. (B.20045, 20299; P.35.1.560.)
- U.19213a Stone bowl, dark steatite, Type RC.8, ht. 0.085 m., diam. 0.10 m. Pit X, from a plundered PJ/B grave. Pl. 34. (B.20002.)
- U.19214 Cylinder seal, calcite, Vol. X, No. 141. Pit X, from a plundered PJ/B grave. (B.18867.)
- U.19215 Clay model boat with high prow and stern and 4 seats; l. 0.22 m. Pit X, in the PJ/B grave stratum. (B.20010.)
- U.19216 Cylinder seal, shell, Vol. X, No. 155. Pit X, from a plundered PJ/B grave. (B.18883.)
- U.19217 Cylinder seal, steatite, Vol. X, No. 170. Pit X, in the Sargonid grave stratum. (B.18889.)
- U.19218 Gold ear-ring, small lunate type, diam. 0.015 m. Pit X, loose in soil in the stratum of the PJ/B graves. (B.20289.)
- U.19220 Stone bowl, white limestone, Type RC.47, ht. 0.045 m., diam. 0.10 m. Pit X, from a plundered PJ/B grave. (B.20577.)
- U.19221 Stone bowl, veined calcite, Type RC.16a, fragmentary, PJ/B.84.
- U.19222 Stone vase, white calcite, Type RC.64, fragmentary. Pit X, from a plundered PJ/B grave. (P.35.1.596.)
- U.19223 Beads; lapis tubes and ovals, quartzite double conoids, shell rings and small shells pierced as beads. Pit X, from a plundered PJ/B grave. (L.BM.123597.)
- U.19224 Stone bowl, white limestone, Type RC.47, ht. 0.05 m., diam. 0.125 m. Pit X, from a plundered PJ/B grave. (L.)
- U.19225 Stone bowl, white limestone, Type RC.47, ht. 0.055 m., diam. 0.10 m. Pit X, from a plundered PJ/B grave. (B.20565.)
- U.19226 Stone bowl, white limestone, Type RC.15a, ht. 0.06 m., diam. 0.155 m. Pit X, from a plundered PJ/B grave. (B.19964.)
- U.19227 Stone bowl, white limestone, Type RC.47, ht. 0.045 m., diam. 0.13 m. Pit X, from a plundered PJ/B grave. (L.)
- U.19228 Stone vase, white calcite, Type RC.61a, ht. 0.14 m., diam. 0.077 m. Pit X, from a plundered PJ/B grave. (B.19915.)
- U.19229 Stone bowl, white limestone, Type RC.47, ht. 0.045 m., diam. 0.125 m. Pit X, from a plundered PJ/B grave. (B.19961.)
- U.19230 Cylinder seal, shell, Vol. X, No. 154. PJ/B.88. (P.35.1.3.)
- U.19231 Beads; carnelian rings and 2 steatite barrels. JNG/204. (B.)
- U.19232 Beads; carnelian rings, one carnelian cylinder and lapis-lazuli balls. JNG/201. Pl. 27. (L.BM.123599.)
- U.19233 Beads; carnelian rings and one shell tube. JNG/198. (B.20061.)
- U.19234 Beads; carnelian rings. JNG/212. (P.35.1.85.)
- U.19235 Beads; 4 shell tubes (L. 0.135 m. - 0.15 m.); 4 carnelian and 4 crystal rings. JNG/216. (P.35.1.68.)

- U.19236 Beads; carnelian ball, date-shaped and cylindrical; lapis date-shaped and faceted date-shaped; shell squares and double conoids. Pit X, from a plundered JNG grave. (L.)
- U.19237 Beads; carnelian cylinders, shell cylinders and lapis-lazuli rings. JNG/210. Pl. 27. (L.BM.123600.)
- U.19238 Stone vase, white calcite, Type RC.54, ht. 0.06 m., diam. 0.11 m. PJ/B.89. (L.)
- U.19239 Beads; lapis-lazuli double conoids and one carnelian cylinder. PJ/B.89. (L.)
- U.19240 Beads; small paste ringed tubes; lapis ovals; one carnelian tube and one crystal pear pendant. Pit X, from a plundered PJ/B grave. (B.20321.)
- U.19241 Stone bowl, grey steatite, Type RC.16a, ht. 0.08 m., diam. 0.14 m. with incomplete inscription of dedication. Pit X, from a plundered PJ/B grave. Pl. 35. (B.20603.)
- U.19242 Cylinder seal, shale, Vol. X, No. 222. Pit X, from a plundered PJ/B grave, Level 5.50 m. (B.18897.)
- U.19243 Stone bowl, steatite, Type RC.51, ht. 0.08 m., diam. 0.155 m.; broken and rivetted in antiquity. PJ/B.82. (B.30770.)
- U.19244 Stone vase, white limestone, Type RC.60a; ht. 0.125 m. diam. 0.11 m. Pit X, from a plundered PJ/B grave. (B.20542.)
- U.19245 Cylinder seal, steatite, Vol. X, No. 26. Pit X, from a plundered JNG grave. (L.BM.123575.)
- U.19246 Copper prong; a shaft round in section from which branch off two prongs square in section; a square-section tang was fitted into a wooden handle the top of which was re-inforced with a ring of thin copper 0.14 m. wide and 0.055 m. in diameter. Total l. 0.165 m., width 0.065 m., l. of prongs 0.07 m. and 0.06 m. JNG/189. Pl. 30. (L.BM.123565.)
- U.19247 Beads; shell tubes 0.09 m. and 0.05 m. long, 2 shell flat ovals diamond beads of lapis-lazuli, mother-of-pearl, limestone and paste; small shell rings, paste balls, quartzite rhomboid spacers and paste square spacers. JNG/159b. Pl. 27. (L.BM.123596.)
- U.19248 Beads; four long shell tubes (0.071 m. long) and one long flat shell oval pierced at each end. JNG/158. (B.20372.)
- U.19249 Beads; frit balls, originally blue-glazed but now bleached white, a few carnelian and one steatite rings. Pit X, from a plundered JNG grave. (B.20310.)
- U.19250 Beads; lapis-lazuli barrels and cylinder, carnelian rings, paste long date-shaped, quartzite flattened hexagonal. JNG/161. Pl. 27. (P.35.1.91.)
- U.19251 Beads; carnelian cylinders, quartzite cylinders, lapis-lazuli cylinders, balls and ovals. JNG/179. Pl. 27. (P.35.1.94.)
- U.19252 Beads; carnelian rings. Pit X, from a plundered JNG grave. (P.35.1.81.)
- U.19253 Beads; large carnelian rings, small shell rings and spacer. Pit X, from a plundered JNG grave. (B.20339.)
- U.19254 Beads; very small paste rings and oblong spacers for a necklace of 3 rows of beads. JNG/149. (B.20052.)
- U.19255 Beads; carnelian rings and a few lapis-lazuli balls and flattened ovals. JNG/155. (B.20357.)
- U.19256 Beads; carnelian rings, large black steatite rings, large shell and black steatite tubes, very small shell rings and a calcite button. JNG/197. (B.20328.)
- U.19257 Beads; large carnelian rings. JNG/188. (B.20319.)
- U.19258 Beads; carnelian rings. Pit X, from a plundered JNG grave. (P.35.1.80.)
- U.19259 Beads; carnelian rings. JNG/190. (B.20362.)
- U.19260 Stone bowl, basic diorite, Type JN.4, ht. 0.065 m., diam. 0.12 m. JNG/154. (P.35.1.207.)
- U.19261 Stone bowl, white limestone, Type JN.30, ht. 0.08 m., diam. 0.10 m. JNG/158. (L.BM.)
- U.19262 Stone bowl, diorite, Type JN.21, ht. 0.025 m., diam. 0.105 m. JNG/160. (B.19852.)
- U.19263 Stone vase, white limestone, Type 56, ht. 0.10 m., diam. 0.13 m. JNG/144. Pl. 34. (B.19981.)
- U.19264 Stone bowl, white limestone, Type JN.24, ht. 0.07 m., diam. 0.165 m. JNG/160. (L.)
- U.19265 Stone tumbler, basic diorite, Type JN.9, ht. 0.09 m., diam. 0.12 m. JNG/150. Pl. 34. (P.35.1.203.)
- U.19266 Stone bowl, basic diorite, Type JN.22, ht. 0.045 m., diam. 0.105 m. JNG/154. (B.19975.)
- U.19267 Stone bowl, basic diorite, Type JN.25, ht. 0.03 m., diam. 0.09 m. JNG/155. (B.20570.)
- U.19268 Stone bowl, basic diorite, Type JN.10, ht. 0.095 m., diam. 0.17 m. JNG/141. (B.19855.)
- U.19269 Stone bowl, basic diorite, Type JN.4, ht. 0.09 m., diam. 0.13 m. Pit X, from a plundered JNG grave. (L.)
- U.19270 Stone bowl, white calcite, Type JN.57, ht. 0.12 m., diam. 0.13 m. JNG/141. (P.35.1.178.)
- U.19271 Stone bowl, white calcite, Type JN.59, ht. 0.085 m., diam. 0.115 m. JNG/174. (P.35.1.190.)
- U.19272 Stone bowl, basic diorite, Type JN.8, ht. 0.07 m., diam. 0.125 m. JNG/175. (B.19946.)
- U.19274 Stone vase, white calcite, Type JN.57, ht. 0.12 m., diam. 0.15 m. JNG/157. (L.BM.123604.)
- U.19275 Stone vase, white calcite, Type JN.57, ht. 0.115 m., diam. 0.15 m. JNG/159. (B.30850.)
- U.19276 Stone bowl, white limestone, Type JN.8, ht. 0.075 m., diam. 0.135 m. JNG/162. (B.19969.)

- U.19277 Stone vase, white limestone, Type JN.57, ht. 0.115 m., diam. 0.15 m. JNG/159b. (B.30778.)
- U.19278 Stone bowl, basic diorite, Type JN.16, ht. 0.04 m., diam. 0.135 m. JNG/145. (L.)
- U.19279 Stone vase, white calcite, Type JN.57, ht. 0.115 m., diam. 0.16 m. JNG/154. (B.30699.)
- U.19280 Stone bowl, basic diorite, Type JN.29, ht. 0.06 m., diam. 0.155 m. JNG/151. (P.35.1.577.)
- U.19281 Stone bowl, white limestone, Type JN.23, ht. 0.11 m., diam. 0.18 m. JNG/160.
- U.19282 Stone bowl, white calcite, Type JN.4, ht. 0.11 m., diam. 0.14 m. JNG/154. (L.BM.123603.)
- U.19283 Stone vase, white calcite, Type JN.59, ht. 0.125 m., diam. 0.19 m. JNG/154.
- U.19284 Stone bowl, diorite, Type JN.20, ht. 0.055 m., diam. 0.12 m. JNG/150. (P.)
- U.19285 Stone bowl, basic diorite, Type JN.28, ht. 0.13 m. JNG/147. (B.)
- U.19286 Stone vase, white calcite, Type JN.57, ht. 0.14 m., diam. 0.15 m. JNG/155. (L.)
- U.19287 Stone bowl, white calcite, Type JN.19, ht. 0.085 m., diam. 0.19 m. JNG/142. (P.35.1.537.)
- U.19288 Stone bowl, white limestone, Type JN.16, diam. 0.30 m. JNG/148. (P.35.1.543.)
- U.19289 Stone bowl, basic diorite, Type JN.21, ht. 0.04 m., diam. 0.10 m. JNG/154. (B.30857.)
- U.19290 Stone bowl, basic diorite, Type JN.24, ht. 0.11 m., diam. 0.26 m. JNG/156. (B.30881.)
- U.19291 Stone bowl, basic diorite, Type JN.28, ht. 0.10 m., diam. 0.16 m. JNG/173. (P.)
- U.19292 Stone bowl, white limestone, Type JN.12, diam. 0.27 m. JNG/161. (B.30787.)
- U.19293 Stone bowl, basic diorite, Type JN.12, ht. 0.11 m., diam. 0.25 m. JNG/154. (P.)
- U.19294 Stone bowl, basic diorite, Type JN.7, ht. 0.085 m., diam. 0.135 m. JNG/146. (B.30851.)
- U.19295 Stone bowl, basic diorite, Type JN.8, ht. 0.11 m., diam. 0.14 m. JNG/157. (L.)
- U.19296 Stone bowl, basic diorite, Type JN.24, ht. 0.085 m., diam. 0.20 m. JNG/157. (P.)
- U.19297 Stone trough, white limestone, rectangular, ht. 0.055 m., 0.145 m. x 0.10 m. JNG/154.
- U.19298 Clay vase, Type JN.33 (an imitation of the stone type JN.57) in black clay, burnished; ht. 0.07 m., diam. 0.09 m. JNG/143. Pl. 25. (L.BM.123564.)
- U.19299 Stone bowl, basic diorite, Type JN.24, ht. 0.09 m., diam. 0.16 m. JNG/153. (B.30771.)
- U.19300 Stone bowl, basic diorite, Type JN.24, ht. 0.09 m., diam. 0.19 m. JNG/152.
- U.19301 Stone vase, white limestone, Type JN.15, ht. 0.06 m., diam. 0.20 m. JNG/152.
- U.19302 Stone bowl, white limestone, Type JN.45, ht. 0.20 m., diam. 0.25 m. JNG/157. (B.30790.)
- U.19303 Stone bowl, white limestone, Type JN.24, ht. 0.09 m., diam. 0.185 m. JNG/159. (B.19850.)
- U.19304 Stone bowl, basic diorite, Type JN.1, ht. 0.07 m., diam. 0.15 m. JNG/182. (L.BM.123607.)
- U.19305 Stone bowl, basic diorite, Type JN.8, ht. 0.075 m., diam. 0.12 m. JNG/173. (P.35.1.567.)
- U.19306 Stone vase, white limestone, Type JN.35, ht. 0.11 m., diam. 0.09 m. JNG/173. (B.20544.)
- U.19307 Stone bowl, basic diorite, Type JN.12, ht. 0.08 m., diam. 0.19 m. JNG/173. (B.30829.)
- U.19308 Stone bowl, basic diorite, Type JN.4, ht. 0.07 m., diam. 0.105 m. JNG/180. (B.19880.)
- U.19309 Stone bowl, diorite, Type JN.24, ht. 0.06 m., diam. 0.10 m. Pit X, from a plundered JNG grave. (B.19846.)
- U.19310 Stone vase, white calcite, Type JN.57, ht. 0.035 m., diam. 0.035 m. Pit X, from a plundered JNG grave. (B.20003.)
- U.19311 Stone vase, white calcite, Type JN.57, ht. 0.04 m., diam. 0.05 m. Pit X, from a plundered JNG grave. (L.)
- U.19312 Stone bowl, basic diorite, Type JN.24, ht. 0.08 m., diam. 0.16 m. JNG/177. (B.30773.)
- U.19313 Stone bowl, white limestone, Type JN.27, ht. 0.11 m., diam. 0.18 m. JNG/182. (B.30836.)
- U.19314 Stone bowl, white calcite, Type JN.26, ht. 0.085 m., diam. 0.165 m. JNG/181. (B.30797.)
- U.19315 Stone bowl, basic diorite, Type JN.12, ht. 0.11 m., diam. 0.25 m. JNG/154.
- U.19316 Beads; grey-green paste cylinders and carnelian cylinders. Pit X, from a plundered JNG grave. (B.20320.)
- U.19317 Stone bowl, white limestone, Type JN.20, ht. 0.075 m., diam. 0.15 m. JNG/160. (L.)
- U.19318 Stone bowl, basic diorite, Type JN.8, ht. 0.11 m., diam. 0.18 m. JNG/156. (B.30835.)
- U.19319 Stone bowl, basic diorite, Type JN.9, ht. 0.11 m., diam. 0.145 m. JNG/188. Pl. 32. (L.BM.123606.)
- U.19320 Stone bowl, basic diorite, Type JN.46, ht. 0.065 m., diam. 0.12 m. Pit X, from a plundered JNG grave. (B.19859.)
- U.19321 Stone bowl, white calcite, Type JN.50, ht. 0.15 m., diam. 0.15 m. JNG/197. (B.30844.)
- U.19322 Stone bowl, diorite, Type JN.24, ht. 0.05 m., diam. 0.12 m. JNG/188. (L.)
- U.19323 Stone bowl, white limestone, Type JN.49, ht. 0.095 m., diam. 0.085 m. JNG/186b. (B.19873.)
- U.19324 Stone bowl, basic diorite, Type JN.22, ht. 0.06 m., diam. 0.12 m. JNG/191. (B.19943.)
- U.19325 Stone bowl, basic diorite, Type JN.12, ht. 0.09 m., diam. 0.22 m. JNG/186b. (P.35.1.576.)
- U.19326 Stone bowl, white limestone, Type JN.24, ht. 0.07 m., diam. 0.13 m. JNG/190. (B.20593.)
- U.19327 Stone bowl, basic diorite, Type JN.12, ht. 0.065 m., diam. 0.17 m. JNG/187a. (B.30796.)
- U.19328 Stone bowl, white calcite, Type JN.57, ht. 0.09 m., diam. 0.12 m. JNG/188. (B.19979.)
- U.19329 Stone bowl, fine white limestone, Type JN.24, ht. 0.065 m., diam. 0.14 m. JNG/197. (B.19945.)
- U.19330 Stone bowl, fine white limestone, Type JN.24, ht. 0.085 m., diam. 0.21 m. JNG/189.
- U.19331 Stone bowl, fine white limestone, Type JN.4, ht. 0.075 m., diam. 0.11 m. JNG/179. (B.30839.)

- U.19332 Stone bowl, white limestone Type JN.13, ht. 0.065 m., diam. 0.019 m. JNG/198. (B.30702.)
- U.19333 Stone bowl, basic diorite, Type JN.20, ht. 0.065 m., diam. 0.13 m. JNG/185. (B.19974.)
- U.19334 Stone bowl, white limestone, Type JN.22, ht. 0.07 m., diam. 0.155 m. Pit X, from a plundered JNG grave. (B.19848.)
- U.19335 Stone bowl, white limestone, Type JN.22, ht. 0.04 m., diam. 0.10 m. Pit X, from a plundered JNG grave. (B.19868.)
- U.19336 Stone bowl, basic diorite, Type JN.23, ht. 0.05 m., diam. 0.085 m. JNG/188. (B.19870.)
- U.19337 Stone bowl, basic diorite, Type JN.40, ht. 0.10 m., diam. 0.13 m. JNG/198. (B.30753.)
- U.19338 Stone bowl, white limestone, Type JN.39, ht. 0.13 m., diam. 0.20 m. JNG/194. (L.BM.)
- U.19339 Stone bowl, white limestone, Type JN.25, ht. 0.08 m., diam. 0.23 m. JNG/185. (B.30783.)
- U.19340 Stone bowl, basic diorite, Type JN.8, ht. 0.09 m., diam. 0.14 m. JNG/186a. (B.19957.)
- U.19341 Stone bowl, basic diorite, Type JN.9, ht. 0.075 m., diam. 0.16 m. JNG/194. (P.35.1.532.)
- U.19342 Stone vase, white calcite, Type JN.50, ht. 0.045 m., diam. 0.045 m. JNG/188. (B.19998.)
- U.19343 Stone bowl, white limestone, Type JN.27, ht. 0.11 m., diam. 0.18 m. JNG/182. (B.30847.)
- U.19344 Stone bowl, basic diorite, Type JN.19, ht. 0.03 m., diam. 0.085 m. JNG/176. (B.19977.)
- U.19346 Stone bowl, basic diorite, Type JN.1, ht. 0.04 m., diam. 0.10 m. Pit X, from a plundered JNG grave. (B.30704.)
- U.19347 Stone bowl, pink limestone, Type JN.4, ht. 0.065 m., diam. 0.10 m. JNG/193. (B.30703.)
- U.19348 Stone bowl, basic diorite, Type JN.24, ht. 0.10 m., diam. 0.21 m. Pit X, from a plundered JNG grave. (B.30884.)
- U.19349 Stone bowl, basic diorite, Type JN.40, ht. 0.10 m., diam. 0.15 m. Pit X, from a plundered JNG grave. (L.BM.123608.)
- U.19350 Clay bowl, Type JN.9, of brown smother-kiln ware, ht. 0.05 m., diam. 0.10 m. Pit X, from a plundered JNG grave. Pl. 25. (L.BM.123613.)
- U.19351 Stone bowl, basic diorite, Type JN.8, ht. 0.14 m., diam. 0.18 m. Pit X, from a plundered JNG grave. (B.30865.)
- U.19352 Stone bowl, basic diorite, Type JN.19, ht. 0.045 m., diam. 0.085 m. Pit X, from a plundered JNG grave. (B.19951.)
- U.19353 Stone bowl, basic diorite, Type JN.24, ht. 0.05 m., diam. 0.20 m. JNG/204. (B.30765.)
- U.19354 Stone bowl, white limestone, Type JN.24, ht. 0.05 m., diam. 0.20 m. JNG/204. (B.30766.)
- U.19355 Stone bowl, white limestone, Type JN.12, ht. 0.09 m., diam. 0.20 m. JNG/210. (B.30804.)
- U.19356 Stone bowl, pink limestone, Type JN.13, ht. 0.07 m., diam. 0.21 m. JNG/199. Pl. 32. (L.BM.123559.)
- U.19357 Stone bowl, basic diorite, Type JN.10, ht. 0.55 m., diam. 0.12 m. JNG/205. (B.30853.)
- U.19358 Stone bowl, basic diorite, Type JN.4, ht. 0.09 m., diam. 0.17 m. JNG/214. (L.)
- U.19359 Stone bowl, basic diorite, Type JN.24, ht. 0.05 m., diam. 0.11 m. JNG/204. (P.35.1.408.)
- U.19360 Stone bowl, fine white limestone, Type JN.13, ht. 0.09 m., diam. 0.21 m. JNG/201. (B.19968.)
- U.19361 Stone bowl, basic diorite, Type JN.4, ht. 0.03 m., diam. 0.13 m. Pit X, from a plundered JNG grave. (L.)
- U.19362 Stone bowl, basic diorite, Type JN.4, ht. 0.085 m., diam. 0.14 m. JNG/213.
- U.19363 Stone bowl, white limestone, Type JN.19, ht. 0.07 m., diam. 0.20 m. JNG/200. (P.35.1.536.)
- U.19364 Stone bowl, basic diorite, Type JN.8, ht. 0.06 m., diam. 0.12 m. JNG/209. (B.30832.)
- U.19365 Stone bowl, white limestone, Type JN.20, ht. 0.045 m., diam. 0.09 m. Pit X, from a plundered JNG grave. (B.19936.)
- U.19366 Stone bowl, white limestone, Type JN.9, ht. 0.135 m., diam. 0.185 m. Pit X, from a plundered JNG grave.
- U.19367 Stone bowl, basic diorite, Type JN.9, ht. 0.11 m., diam. 0.15 m. JNG/199. (P.35.1.573.)
- U.19368 Stone bowl, basic diorite, Type JN.24, ht. 0.055 m., diam. 0.12 m. JNG/206. (L.)
- U.19369 Stone bowl, basic diorite, Type JN.20, ht. 0.06 m., diam. 0.12 m. JNG/198. (L.)
- U.19370 Stone bowl, basic diorite, Type JN.24, ht. 0.03 m., diam. 0.08 m. JNG/211. (P.)
- U.19371 Stone bowl, white limestone, Type JN.8, ht. 0.055 m., diam. 0.075 m. JNG/201.
- U.19372 Stone bowl, white limestone, Type JN.12, ht. 0.08 m., diam. 0.21 m. Pit X, from a plundered JNG grave. (B.30751.)
- U.19373 Stone bowl, white limestone, Type JN.9, ht. 0.055 m., diam. 0.10 m. JNG/197. (P.35.1.554.)
- U.19374 Stone vase, white calcite, Type JN.49, ht. 0.035 m., diam. 0.035 m. JNG/197. (B.19836.)
- U.19375 Stone bowl, white limestone, Type JN.4, ht. 0.075 m., diam. 0.13 m. JNG/205. (P.35.1.563.)
- U.19376 Stone bowl, basic diorite, Type JN.10, ht. 0.075 m., diam. 0.11 m. JNG/205. (B.20568.)
- U.19377 Stone bowl, white limestone, Type JN.47, ht. 0.06 m., diam. 0.065 m. Pit X, from a plundered JNG grave. (B.19992.)
- U.19378 Stone cup, white limestone, Type JN.40, ht. 0.06 m., diam. 0.065 m., the outside carved in low relief with a leaf design. JNG/211. Pl. 31. (B.19831.)
- U.19379 Stone bowl, basic diorite, Type JN.22, ht. 0.04 m., diam. 0.09 m. Pit X, from a plundered JNG

- grave. (B.19929.)
- U.19380 Stone bowl, basic diorite, Type JN.12, ht. 0.095 m., diam. 0.20 m. JNG/186b. (B.30744.)
- U.19381 Stone vase, white calcite, Type JN.50, ht. 0.20 m., diam. 0.15 m. JNG/199. (B.30774.)
- U.19382 Stone vase, white calcite, Type JN.48, ht. 0.10 m., diam. 0.125 m. JNG/194. (B.30849.)
- U.19383 Stone bowl, pink limestone, Type JN.10, ht. 0.065 m., diam. 0.11 m. JNG/191. (P.35.1.593.)
- U.19384 Stone vase, white calcite, Type JN.59, ht. 0.11 m., diam. 0.15 m. JNG/218.
- U.19385 Stone bowl, basic diorite, Type JN.19, ht. 0.04 m., diam. 0.12 m. JNG/208.
- U.19386 Stone bowl, diorite, Type JN.10, ht. 0.07 m., diam. 0.12 m. Pit X, from a plundered JNG grave. (P.35.1.568.)
- U.19387 Stone bowl, white limestone, Type JN.39, ht. 0.16 m., diam. 0.18 m. JNG/200. (L.)
- U.19388 Stone bowl, white limestone, Type JN.8, ht. 0.08 m. JNG/217. (B.30837.)
- U.19389 Stone bowl, white limestone, Type JN.24, ht. 0.06 m., diam. 0.11 m. JNG/218. (L.)
- U.19390 Stone bowl, diorite, Type JN.23, ht. 0.04 m., diam. 0.09 m. Pit X, from a plundered JNG grave.
- U.19391 Stone bowl, basic diorite, Type JN.16, ht. 0.05 m., diam. 0.11 m. Pit X, from a plundered JNG grave. (L.)
- U.19392 Stone bowl, basic diorite, Type JN.13, ht. 0.06 m., diam. 0.18 m. JNG/205. (B.30786.)
- U.19393 Stone bowl, fine white limestone, Type JN.8, ht. 0.09 m., diam. 0.10 m. JNG/193. (P.35.1.578.)
- U.19394 Stone bowl, white limestone, Type JN.12, ht. 0.095 m., diam. 0.23 m. JNG/192. (B.30891.)
- U.19395 Stone bowl, basic diorite, Type JN.13, ht. 0.10 m., diam. 0.22 m., Pit X, from a plundered JNG grave. (B.30892.)
- U.19396 Stone bowl, basic diorite, Type JN.20, ht. 0.05 m., diam. 0.095 m. Pit X, from a plundered JNG grave.
- U.19397 Stone bowl, white limestone, Type JN.24, ht. 0.05 m., diam. 0.11 m. JNG/206. (B.19965.)
- U.19398 Stone bowl, white limestone, Type JN.15, ht. 0.07 m., diam. 0.21 m. JNG/174.
- U.19399 Stone bowl, coarse white limestone, Type JN.45, ht. 0.23 m., diam. 0.24 m. JNG/210. (B.19913.)
- U.19400 Stone vase, alabaster, Type JN.57, ht. 0.125 m., diam. 0.125 m. JNG/219. (B.19978.)
- U.19401 Stone vase, alabaster, Type JN.57, ht. 0.17 m., diam. 0.18 m. JNG/220. Pl. 33. (B.19845.)
- U.19402 Stone bowl, diorite, Type JN.31, ht. 0.14 m., diam. 0.12 m. JNG/220. Pl. 33. (P.35.1.205.)
- U.19403 Stone bowl, diorite, Type JN.6, ht. 0.08 m., diam. 0.12 m. JNG/220. (P.35.1.604.)
- U.19404 Stone bowl, diorite, Type JN.1, diam. 0.19 m. JNG/220.
- U.19405 Stone vase, alabaster, Type JN.57, ht. 0.045 m., diam. 0.065 m. JNG/220. (P.35.1.180.)
- U.19406 Stone vase, alabaster, Type JN.57, ht. 0.042 m., diam. 0.07 m. JNG/220. (P.35.1.181.)
- U.19407 Stone vase, alabaster, Type JN.57, ht. 0.055 m., diam. 0.08 m. JNG/220. (L.BM.)
- U.19408 Stone tumbler, grey steatite, Type JN.32, ht. 0.087 m., diam. 0.08 m. JNG/221. (B.19927.)
- U.19409 Stone vase, alabaster, Type JN.56, ht. 0.065 m., diam. 0.09 m. JNG/221. (P.35.1.521.)
- U.19410 Two stone vases, white calcite, Type JN.56, ht. 0.06 m. and 0.05 m. resp. JNG/221. (B.19991.)
- U.19411 Two stone vases, white calcite, Type JN.56, ht. 0.045 m. and 0.055 m. resp. JNG/221. (B.19995, 20558.)
- U.19412 Two stone vases, white calcite, Type JN.56, ht. 0.03 m. and 0.075 m. resp. JNG/221. (B.30734.)
- U.19413 Stone vase, diorite, Type JN.56, ht. 0.06 m., diam. 0.075 m. JNG/221. (P.35.1.200.)
- U.19414 Two stone vases, white calcite, Type JN.56, ht. 0.03 m. and 0.035 m. respectively. JNG/221. Pl. 32. (B. and P.35.1.188.)
- U.19415 Stone bowl, white calcite, Type JN.28, ht. 0.05 m., diam. 0.07 m. JNG/221. Pl. 32. (P.35.1.189.)
- U.19416 Stone vase, alabaster, Type JN.59, ht. 0.055 m., diam. 0.06 m. JNG/226. (B.19997.)
- U.19417 Stone bowl, diorite, Type JN.24, ht. 0.10 m., diam. 0.18 m., with a band in relief below the rim. JNG/223. Pl. 33. (B.30750.)
- U.19418 Stone bowl, diorite, ht. 0.10 m., diam. 0.16 m. JNG/223. (B.30721.)
- U.19419 Stone bowl, white limestone, Type JN.24, ht. 0.09 m., diam. 0.17 m. JNG/222. (L.)
- U.19420 Stone bowl, white limestone, Type JN.24, ht. 0.055 m., diam. 0.135 m. Pit X, from a plundered JNG grave. (P.35.1.547.)
- U.19421 Stone bowl, diorite, Type JN.4, ht. 0.105 m., diam. 0.135 m. JNG/222. (B.30802.)
- U.19422 Stone bowl, diorite, Type JN.24, ht. 0.06 m., diam. 0.105 m. JNG/226. (B.20608.)
- U.19423 Stone bowl, white limestone, Type JN.24, ht. 0.09 m., diam. 0.18 m. JNG/226. (B.30700.)
- U.19424 Stone vase, white limestone, Type JN.57, ht. 0.14 m., diam. 0.16 m. JNG/227. (P.35.1.525.)
- U.19425 Stone bowl, veined calcite, Type RC.25, ht. 0.03 m., diam. 0.175 m. Pit X, loose in the soil on the level of the lowest graves of the PGB series, level 5.00 m. (P.35.1.526.)
- U.19426 Kohl-pot, alabaster; half of; originally two round vases (with holes in the rims for revolving lids) made in one piece and supported by the figure of a reclining ram, rather roughly carved. It is broken, and only one vase and the front part of the ram's figure remain. Ht. 0.05 m., l. 0.06 m. Pit X, loose in the soil of the stratum of the JNG graves. Level 5.30 m. Pl. 31. (B.19842.)
- U.19427 Kohl-pot, alabaster, rectangular with two circular receptacles for the kohl; round the edge a

- band of rope moulding. Ht. 0.034 m., l. 0.045 m., width 0.037 m. Pit X, loose in the soil of the stratum of the JNG graves, level 5.20 m. (B.19835.)
- U.19428 Kohl-pot, alabaster, shaped as a rectangular coffer or urn on 4 short legs; round the edge a band of rope moulding; 2 circular receptacles for kohl. Ht. 0.04 m., l. 0.09 m., width 0.05 m. Pit X, loose in soil, level 5.20 m. Pl. 31. (P.35.1.42.)
- U.19429 Stone vase, alabaster, Type JN.59, ht. 0.03 m., diam. 0.03 m. Pit X, loose in the soil of the JNG grave stratum. (P.35.1.185.)
- U.19430 Beads; carnelian rings and one tube; lapis balls; balls of black and white marble; one quartzite lozenge and 4 red chalcedony date-shaped. Pit X, from a plundered JNG grave. Pl. 27. (L.BM.123601.)
- U.19431 Beads; reddish-brown chalcedony date-shaped alternating with lapis balls and one crescent-shaped lapis; worn as a garter. JNG/220. (B.20363.)
- U.19432 Stone bowl, diorite, Type RC.51, ht. 0.09 m., diam. 0.17 m. PJ/B.90. (B.20548.)
- U.19433 Stone bowl, veined calcite, Type RC.19d, fragmentary; Pit X, from a plundered PJ/B grave. Broken and rivetted in antiquity. (P.35.1.583.)
- U.19434 Stone bowl, veined calcite, Type RC.24, ht. 0.065 m., diam. 0.16 m. Pit X, from a plundered PJ/B grave. (P.35.1.525.)
- U.19435 Beads; carnelian balls and short date-shaped; lapis balls; balls of black and white marble. JNG/220. (B.20312.)
- U.19436 Stone tumbler, white limestone, Type JN.6, ht. 0.08 m., diam. 0.10 m. JNG/220. Pl. 32. (L.BM.123562.)
- U.19439 Terra-cotta figurine of an animal, hand-modelled in buff clay with details in black paint; hind-quarters and forelegs missing, l. 0.10 m. Pit X, level 3.00 m. Pl. 21. (B.20026.)
- U.19440 Stone vase, white calcite, Type JN.28, ht. 0.022 m., diam. 0.025 m. JNG/159. (B.20000.)
- U.19441 Copper pin, Type RC.1, with ball head made of segments of shell and of black steatite to imitate banded agate, l. 0.115 m. Pit X, from a plundered PJ/B grave. (L.)
- U.19442 Stone vase, white calcite, Type RC.60b, ht. 0.13 m., diam. 0.065 m. Pit X, from a plundered PJ/B grave. (B.20547.)
- U.19443 Stone vase, white calcite, Type RC.60b, ht. 0.125 m., diam. 0.07 m. PJ/B.58. (B.19876.)
- U.19444 Beads; lapis balls and double conoids; silver ditto; a few carnelian rings. Also 2 ear-rings of spirally-wound silver wire, diam. 0.04 m. JNG/219. (B.20049.)
- U.19445 Stone bowl, dark steatite, Type JN.17, ht. 0.02 m., diam. 0.065 m. Pit X, from a plundered JNG grave. (B.19914.)
- U.19446 Gold ear ring, small lunate type, diam. 0.011 m. Pit X, loose in the soil. (B.20287.)
- U.19447 Cylinder seal, shell, l. 0.031 m., diam. 0.014 m. Fighting animals. Pit X, loose in the soil of the stratum of the PJ/B graves. (B.18893.)
- U.19448 Conch shell cut open to serve as a lamp and carved below with a flat knob base in which are 2 holes for attachment to a support. JNG/215. (L.BM.123613.)
- U.19449 Stone bowl, white limestone, Type JN.12, ht. 0.08 m., diam. 0.23 m. Pit X, from a plundered JNG grave. (B.30887.)
- U.19450 Stone bowl, white limestone, Type JN.12, ht. 0.08 m., diam. 0.032 m. JNG/189. (L.)
- U.19451 Stone bowl, white limestone, Type JN.15, ht. 0.115 m., diam. 0.32 m. JNG/187b. (B.30861.)
- U.19452 Stone bowl, coarse white limestone, Type JN.24, ht. 0.10 m., diam. 0.21 m. Pit X, from a plundered JNG grave. (B.30716.)
- U.19453 Stone bowl, white limestone, Type JN.24. Pit X, from a plundered JNG grave. (B.30871.)
- U.19454 Stone bowl, pink limestone, Type JN.22, ht. 0.04 m., diam. 0.0115 m. Pit X, from a plundered JNG grave. (P.35.1.549.)
- U.19455 Stone bowl, diorite, Type JN.17, ht. 0.03 m., diam. 0.085 m. Pit X, from a plundered JNG grave. (P.)
- U.19456 Stone tumbler, diorite, Type JN.30, fragmentary. Pit X, from a plundered JNG grave. (B.30746.)
- U.19457 Stone bowl, white calcite, Type RC.48, ht. 0.045 m., diam. 0.09 m. Pit X, from a plundered PJ/B grave. (B.20576.)
- U.19458 Stone bowl, white calcite, Type RC.48, ht. 0.04 m., diam. 0.09 m. Pit X, from a plundered PJ/B grave. (P.35.1.556.)
- U.19459 Stone bowl, white limestone, Type RC.47, ht. 0.05 m., diam. 0.105 m. Pit X, from a plundered PJ/B grave. (B.19884.)
- U.19460 Stone bowl, veined calcite, Type RC.9, ht. 0.06 m., diam. 0.075 m. Pit X, from a plundered PJ/B grave. (B.20557.)
- U.19461 Stone bowl, diorite, Type JN.26, ht. 0.095 m., diam. 0.21 m. Pit X, from a plundered JNG grave. (L.)
- U.19462 Stone cup, diorite, Type JN.39, ht. 0.05 m., diam. 0.07 m. Pit X, from a plundered JNG grave. (L.)

- U.19463 Three stone bowls, diorite, two of Type JN.24, one probably of Type JN.4; fragmentary. JNG/193. (P.35.1.603.)
- U.19464 Stone bowl, white limestone, Type JN.8, ht. 0.05 m., diam. 0.11 m. Pit X, from a plundered JNG grave. (P.)
- U.19465 Stone bowl, dark steatite, Type JN.23, ht. 0.055 m., diam. 0.14 m. Pit X, from a plundered JNG grave. (P.35.1.606.)
- U.19466 Stone bowl, white limestone, Type JN.45, ht. 0.20 m., diam. 0.24 m. Pit X, from a plundered JNG grave. (L.)
- U.19467 Stone bowl, diorite, Type JN.10, ht. 0.05 m., diam. 0.165 m. JNG/199. (P.)
- U.19468 Stone bowl, basic diorite, Type JN.24, ht. 0.055 m., diam. 0.165 m. Pit X, from a plundered JNG grave.
- U.19469 Stone bowl, diorite, Type JN.10, ht. 0.05 m. JNG/197. (P.)
- U.19470 Stone vase, white calcite, Type JN.49, ht. 0.03 m., diam. 0.03 m. Pit X, from a plundered JNG grave. (B.20004.)
- U.19471 Stone bowl, white limestone, Type JN.8, ht. 0.13 m., diam. 0.185 m. Pit X, from a plundered JNG grave. (B.30808.)
- U.19474 Stone bowl, diorite, Type JN.4, fragmentary. Pit X, from a plundered JNG grave. (L.)
- U.19476 Stone bowl, basic diorite, Type JN.12, fragmentary. Pit X, from a plundered JNG grave.
- U.19478 Stone bowl, basic diorite, Type JN.15, ht. 0.10 m., diam. 0.225 m. Pit X, from a plundered JNG grave. (B.30883.)
- U.19480 Stone bowl, diorite, Type JN.9, ht. 0.05 m., diam. 0.075 m. Pit X, from a plundered JNG grave. (B.19937.)
- U.19481 Stone vase, calcite, Type JN.49, ht. 0.025 m., diam. 0.025 m. Pit X, from a plundered JNG grave. (B.20006.)
- U.19485 Cylinder seal, calcite, Vol. X, No. 41, Pit X, level 5.50 m., in the remains of a plundered PJ/B grave. (B.18894.)
- U.19490 Stone bowl, fine white limestone, Type JN.18, ht. 0.05 m., diam. 0.11 m. Pit X, from a plundered JNG grave. (B.30782.)
- U.19491 Stone bowl, diorite, Type JN.9, ht. 0.055 m., diam. 0.10 m. Pit X, from a plundered JNG grave. (P.35.1.213.)
- U.19492 Stone vase, calcite, Type JN.56, ht. 0.10 m., diam. 0.145 m. Pit X, from a plundered JNG grave. (B.30809.)
- U.19493 Stone bowl, calcite, Type JN.16, ht. 0.04 m., diam. 0.10 m. Pit X, from a plundered JNG grave. (B.20556.)
- U.19494 Copper mirror (?); a flat disk of thin metal with short tang for attachment to the handle. L. 0.11 m., diam. 0.10 m., total length with tang 0.13 m. Pit X, loose in the soil in the JNG grave stratum. (P.35.1.434.)
- U.19495 Terra-cotta model of a boat with very high prow and stern; ht. 0.07 m., l. 0.115 m., width 0.055 m. Pit X, at the very bottom of the PJ/B graves stratum and probably belonging to the earlier rubbish. (L.BM.123614.)
- U.19496 Copper mixing-spoon (?); a long handle formed of a rod square in section twisted on itself to give a spiral effect; the blade is of very thin metal, spade-shaped, 0.035 m. long and 0.027 m. wide; total l. 0.34 m. Pit X, loose in soil. (L.BM.)
- U.19497 Copper razor (?); very thin metal, straight-sided, the cutting edge at the end, and a short tang; total l. 0.13 m., l. of blade 0.09 m., width 0.045 m. JNG/177. (B.20117.)
- U.19498 Stone bowl, basic diorite, Type JN.4, ht. 0.07 m., diam. 0.045 m. Pit X, from a plundered JNG grave. (B.20573.)
- U.19499 Stone bowl, diorite, Type JN.15, ht. 0.02 m., diam. 0.065 m. Pit X, from a plundered JNG grave. (B.20549.)
- U.19500 Stone bowl, limestone, Type JN.24, ht. 0.09 m., diam. 0.13 m. JNG/227. (P.35.1.544.)
- U.19501 Stone bowl, white limestone, Type RC.48, ht. 0.07 m., diam. 0.13 m. PJ/B.98. (B.20566.)
- U.19502 Stone bowl, white limestone, Type JN.24, ht. 0.13 m., diam. 0.17 m. JNG/228. (B.30795.)
- U.19503 Stone cup, basic diorite, Type JN.8, ht. 0.09 m., diam. 0.115 m. JNG/228. (P.35.1.206.)
- U.19504 Stone bowl, diorite, Type JN.24, ht. 0.10 m., diam. 0.19 m. JNG/230.
- U.19505 Stone vase, alabaster, Type JN.57, ht. 0.115 m., diam. 0.15 m. JNG/230. (P.35.1.177.)
- U.19506 Stone cup, limestone, Type JN.8, ht. 0.075 m., diam. 0.095 m. JNG/230. (B.19857.)
- U.19507 Stone bowl, diorite, Type JN.13, ht. 0.055 m., diam. 0.17 m. JNG/230. (P.35.1.219.)
- U.19508 Stone bowl, basic diorite, Type JN.39, ht. 0.065 m., diam. 0.095 m. Pit X, from a plundered JNG grave. (L.)
- U.19509 Stone vase, alabaster, Type JN.57, ht. 0.13 m., diam. 0.175 m. Pit X, from a plundered JNG grave.



- U.19510 Stone bowl, basic diorite, Type JN.1, diam. 0.125 m. JNG/229. (B.19954.)
- U.19511 Stone bowl, white limestone, Type JN.1, ht. 0.06 m., diam. 0.16 m. Pit X, from a plundered JNG grave. (B.20558.)
- U.19512 Stone vase, white calcite, Type JN.24, ht. 0.075 m., diam. 0.09 m. JNG/229. (L.)
- U.19513 Stone tumbler, diorite, Type JN.29, ht. 0.085 m., diam. 0.065 m. JNG/229. Pl. 34. (P.35.1.202.)
- U.19514 Stone vase, white calcite, Type JN.42, ht. 0.10 m., diam. 0.24 m. JNG/221.
- U.19515 Stone vase, white limestone, Type JN.51 (variant), ht. 0.12 m., diam. 0.08 m. JNG/221. (L.)
- U.19516 Stone bowl, basic diorite, Type JN.10, ht. 0.08 m., diam. 0.14 m. JNG/221. (P.35.1.585.)
- U.19517 Stone bowl, alabaster, Type JN.62, ht. 0.20 m., diam. 0.18 m. JNG/221. Pl. 34. (B.19847.)
- U.19518 Stone vase, white calcite, Type JN.57, ht. 0.08 m., diam. 0.11 m. JNG/221. Pl. 34. (B.19877.)
- U.19519 Stone vase, diorite, Type JN.63, ht. 0.29 m., diam. 0.27 m. JNG/221. Pl. 33. (L.BM.123558.)
- U.19520 Stone bowl, fine white limestone, Type JN.9, ht. 0.08 m., diam. 0.10 m. JNG/221. (P.35.1.551.)
- U.19521 Two stone vases, white calcite, Type JN.57, ht. 0.125 m. and 0.22 m. resp. JNG/221. (L.)
- U.19522 Stone bowl, diorite, Type JN.10, ht. 0.13 m., diam. 0.17 m. JNG/225. (L.)
- U.19523 Stone vase, alabaster, Type JN.57, ht. 0.12 m., diam. 0.14 m. JNG/225.
- U.19524 Stone vase, alabaster, Type JN.57, ht. 0.12 m., diam. 0.16 m. JNG/225. (P.35.1.557.)
- U.19525 Stone bowl, diorite, Type JN.24, fragmentary. JNG/225. (P.35.1.580.)
- U.19526 Two stone vases, white calcite, Type JN.57, fragmentary. JNG/221. (L.)
- U.19527 Stone vase, white calcite, Type JN.57, ht. 0.085 m., diam. 0.12 m. JNG/221. (L.)
- U.19528 Stone vase, white calcite, Type JN.57, ht. 0.07 m., diam. 0.085 m. JNG/221. (B.19989.)
- U.19529 Double kohl-pot, alabaster, Type JN.56, two vases of this type being cut in one piece together with the stand; ht. 0.055 m., diam. 0.06 m. JNG/221. Pl. 31. (B.19830.)
- U.19530 Stone bowl, diorite, ht. 0.03 m., diam. 0.13 m. JNG/224. (B.19958.)
- U.19531 Stone bowl, diorite, Type JN.24, ht. 0.06 m., diam. 0.15 m. JNG/224. (B.30870.)
- U.19532 Stone bowl, fine white limestone, Type JN.15, ht. 0.05 m., diam. 0.12 m. JNG/221.
- U.19533 Two stone vases, white calcite, Type JN.56, ht. 0.05 m. and 0.06 m. resp. JNG/221. (B.19994.) (P.)
- U.19536 Stone cup, dark steatite, Type JN.28, ht. 0.06 m., diam. 0.08 m. Pit X, from a plundered JNG grave. (B.20594.)
- U.19537 Stone vase, white calcite, Type RC.55, PJ/B.96. (B.30708.)
- U.19538 Stone vase, white calcite, Type RC.60b, ht. 0.14 m., diam. 0.08 m. PJ/B.95A. (P.35.1.196.)
- U.19539 Stone vase, white calcite, Type RC.54, ht. 0.045 m., diam. 0.10 m. Pit X, from a plundered PJ/B grave.
- U.19540 Stone bowl, diorite, Type RC.24, ht. 0.03 m., diam. 0.09 m. PJ/B.92. (L.)
- U.19541 Stone bowl, limestone, Type RC.90b, ht. 0.05 m., diam. 0.05 m. PJ/B.92. (B.19999.)
- U.19542 Stone bowl, white limestone, Type RC.48, ht. 0.035 m., diam. 0.10 m. PJ/B.91. (B.19972.)
- U.19543 Stone bowl, white calcite, Type RC.54, ht. 0.05 m., diam. 0.09 m. PJ/B.91. (L.)
- U.19545 Stone bowl, limestone, Type JN.24, ht. 0.055 m., diam. 0.09 m. JNG/231. (L.)
- U.19546 Stone bowl, limestone, Type JN.24, ht. 0.095 m., diam. 0.20 m. JNG/231. (B.30711.)
- U.19547 Stone bowl, white limestone, Type JN.24, ht. 0.125 m., diam. 0.20 m. JNG/231.
- U.19548 Stone bowl, limestone, Type JN.30, ht. 0.12 m., diam. 0.12 m. JNG/231. (B.30728.)
- U.19549 Stone bowl, limestone, Type JN.8, ht. 0.08 m., diam. 0.10 m. Pit X, from a plundered JNG grave. (B.20554.)
- U.19550 Stone bowl, diorite, Type JN.12, ht. 0.065 m., diam. 0.18 m. Pit X, from a plundered JNG grave. (L.)
- U.19551 Clay pot, Type JN.33, ht. 0.11 m., of dark brown clay, burnished. JNG/162. (P.)
- U.19552 Stone tumbler, fine white limestone, Type JN.36, ht. 0.14 m., diam. 0.10 m. Pit X, from a plundered JNG grave. Pl. 34. (L.BM.123561.)
- U.19553 Clay pot, fragment of; of light red clay, the whole body decorated with incised lines, horizontal round the middle and vertical above and below. Pit X, in the upper part of the JNG graves stratum. (P.35.1.592.)
- U.19554 Stone bowl, basic diorite, Type JN.31, ht. 0.145 m., diam. 0.135 m. JNG/221. (L.)
- U.19556 Stone bowl, fine white limestone, Type JN.17, ht. 0.055 m., diam. 0.125 m. Pit X, from a plundered JNG grave. (B.20581.)
- U.19557 Stone bowl, basic diorite, Type JN.30, ht. 0.05 m., diam. 0.065 m. Pit X, from a plundered JNG grave.
- U.19558 Stone bowl, basic diorite, Type JN.28, ht. 0.07 m., diam. 0.12 m. Pit X, from a plundered JNG grave. (P.35.1.216.)
- U.19559 Stone bowl, fine white limestone, Type JN.35, ht. 0.06 m., diam. 0.14 m. Pit X, from a plundered JNG grave. (B.30733.)
- U.19560 Stone bowl, white limestone, Type JN.24, ht. 0.07 m., diam. 0.14 m. Pit X, from a plundered JNG

- grave. (P.35.1.581.)
- U.19561 Stone bowl, coarse white limestone, Type JN.13, ht. 0.08 m., diam. 0.22 m. Pit X, from a plundered JNG grave.
- U.19562 Stone bowl, fine limestone, Type JN.42, ht. 0.06 m., diam. 0.08 m. JNG/221. (P.)
- U.19563 Stone bowl, calcite, Type JN.32, ht. 0.08 m., diam. 0.085 m. JNG/221. (P.)
- U.19564 Stone vase, basic diorite, Type JN.56, ht. 0.06 m., diam. 0.08 m. JNG/221. (B.30737.)
- U.19565 Stone bowl, basic diorite, Type JN.24, ht. 0.04 m., diam. 0.095 m. JNG/221. (B.19890.)
- U.19566 Stone bowl, fine limestone, Type JN.40, ht. 0.07 m., diam. 0.095 m. Pit X, from a plundered JNG grave. (B.19864.)
- U.19567 Stone bowl, calcite, Type JN.59, ht. 0.03 m., diam. 0.05 m. Pit X, from a plundered JNG grave. (B.20001.)
- U.19568 Stone bowl, limestone, Type JN.55, ht. 0.045 m., diam. 0.05 m. Pit X, from a plundered JNG grave. (L.)
- U.19569 Stone bowl, basic diorite, Type RC.19c, ht. 0.025 m., diam. 0.08 m. Pit X, from a plundered grave of the PJ/B series. (B.20585.)
- U.19570 Beads; carnelian and lapis-lazuli balls, small ovals and date-shaped. JNG/225. (B.20069.)
- U.19571 Beads; lapis-lazuli rings and diamonds, quartzite diamonds, marble diamonds, large date-shaped chalcedony. Worn as a garter below the knee. JNG/221. (B.20318.)
- U.19572 Gold ear-ring; a hoop of gold wire partly round and for part of its length square in section; this part has been twisted on itself to produce a cable effect. PJ/B.91. (P.35.1.153.)
- U.19573 Cylinder seal, shell, Vol. X, No. 122. (B.18888.)
- U.19574 Beads; small carnelian and lapis-lazuli balls and rings, minute paste and shell rings; also a shell cylinder with an engraved geometric pattern and inlaid lapis-lazuli dots. PJ/B.96.
- U.19575 Beads; carnelian and chalcedony dumb-bell-shaped beads, carnelian tubes and balls, lapis-lazuli and black and white marble balls, shell date-shaped, and one gold double conoid. JNG/221. Pl. 27. (B.20325, 20359, 20364, and L.BM.123595.)
- U.19576 Beads; small natural shells pierced for stringing—a very large number found in two separate lots in the grave. JNG/221. (B.20365.)
- U.19577 Beads; 3 very long shell tubes, shell cylinders, some small natural shell pierced for stringing, large haematite barrels and carnelian rings. JNG/229.
- U.19578 Cylinder seal, shell; Vol. X, No. 121. Pit X, loose in the soil in the lower part of the stratum containing the PJ/B graves. (B.18915.)
- U.19580 Stone bowl, basic diorite, Type JN.9, ht. 0.10 m., diam. 0.145 m. JNG/234. (P.35.1.538.)
- U.19581 Stone bowl, fine white limestone, Type JN.24, ht. 0.05 m., diam. 0.115 m. JNG/234. (B.30864.)
- U.19582 Stone bowl, basic diorite, Type JN.27, ht. 0.30 m., diam. 0.25 m. JNG/234.
- U.19583 Stone bowl, basic diorite, Type JN.31, ht. 0.12 m., diam. 0.12 m. JNG/234. (L.)
- U.19584 Stone bowl, fine white limestone, Type JN.8, ht. 0.07 m., diam. 0.10 m. Pit X, from a plundered JNG grave. (L.)
- U.19585 Stone bowl, diorite, Type JN.43, ht. 0.045 m., diam. 0.075 m. Pit X, from a plundered JNG grave. (P.35.1.223.)
- U.19586 Stone vase, alabaster, Type JN.57. JNG/233. (B.30789.)
- U.19587 Stone vase, basic diorite, Type JN.8, ht. 0.11 m., diam. 0.14 m. JNG/235. (P.35.1.566.)
- U.19588 Stone bowl, diorite, Type JN.12, ht. 0.10 m., diam. 0.21 m. JNG/232. (B.20601.)
- U.19589 Stone cup, basic diorite, Type JN.8, ht. 0.115 m., diam. 0.145 m. JNG/232. (L.)
- U.19590 Stone bowl, basic diorite, Type JN.24, ht. 0.06 m., diam. 0.16 m. Pit X, from a plundered JNG grave. (P.35.1.564.)
- U.19591 Stone vase, white calcite, Type JN.57, ht. 0.13 m., diam. 0.17 m. Pit X, from a plundered JNG grave. (B.30845.)
- U.19592 Stone bowl, white limestone, Type JN.56, ht. 0.09 m., diam. 0.09 m. Pit X, from a plundered JNG grave. (B.30886.)
- U.19593 Lamp (?) of white limestone; circular bowl diam. 0.09 m. and depth 0.08 m. on a tall pyramidal stand, square, its sides each pierced by two tiers of long and narrow vertical slits. Total ht. 0.28 m., diam. of base 0.12 m. JNG/210. Pl. 33. (B.19911.)
- U.19594 Stone bowl, basic diorite, Type JN.40, ht. 0.04 m., diam. 0.055 m. JNG/221. (P.)
- U.19595 Stone bowl, basic diorite, Type RC.19c., ht. 0.03 m., diam. 0.058 m. PJ/B.95. (B.19976.)
- U.19597 Stone vase, white calcite, Type JN.56, ht. 0.15 m., diam. 0.16 m. Pit X, from a plundered JNG grave. (B.30907.)
- U.19598 Beads; long flat shell oblongs pierced at each end, small natural shells pierced for stringing, and shell rings. JNG/232. (B.20373.)
- U.19599 Stone bowl, white limestone, Type JN.18, ht. 0.035 m., diam. 0.15 m. JNG/236. (L.)
- U.19600 Stone bowl, diorite, Type JN.16, ht. 0.03 m., diam. 0.105 m. Pit X, from a plundered JNG grave. (B.30798.)

- U.19601 Stone bowl, diorite, Type JN.8, ht. 0.075 m., diam. 0.11 m. Pit X, from a plundered JNG grave. (B.30799.)
- U.19602 Clay vase, Type JN.35, a copy in greenish drab clay of the stone Type JN.59. Pit X, from a plundered JNG grave. (B.19916.)
- U.19603 Stone bowl, diorite, Type JN.9, ht. 0.065 m., diam. 0.09 m. Pit X, from a plundered JNG grave. (L.)
- U.19604 Stone bowl, white limestone, Type JN.25, ht. 0.06 m., diam. 0.18 m. JNG/236. (P.35.1.602.)
- U.19605 Stone bowl, diorite, Type JN.8, diam. 0.11 m. JNG/238. (B.30763.)
- U.19606 Stone bowl, white limestone, Type JN.23, ht. 0.11 m., diam. 0.17 m. JNG/237. (P.35.1.598.)
- U.19607 Stone vase, alabaster, Type JN.57, ht. 0.09 m., diam. 0.088 m. JNG/237. (L.)
- U.19608 Stone bowl, diorite, Type JN.8, ht. 0.07 m., diam. 0.12 m. JNG/238. (P.35.1.208.)
- U.19609 Stone bowl, white limestone, Type JN.24, ht. 0.075 m., diam. 0.19 m. JNG/238. (B.30828.)
- U.19610 Stone bowl, white limestone, Type JN.42, ht. 0.04 m., diam. 0.10 m. JNG/239. (B.30726.)
- U.19611 Stone bowl, diorite, Type JN.19, ht. 0.11 m., diam. 0.23 m. JNG/238. (B.30894.)
- U.19612 Stone vase, alabaster, Type JN.59, ht. 0.05 m., diam. 0.065 m. JNG/240. (L.BM.123609.)
- U.19613 Stone bowl, diorite, Type JN.10, ht. 0.065 m., diam. 0.095 m. JNG/240.
- U.19614 Stone bowl, limestone, Type JN.10, ht. 0.09 m., diam. 0.15 m. Pit X, from a plundered JNG grave. (B.19939.)
- U.19615 Stone vase, white calcite, Type JN.59, ht. 0.09 m., diam. 0.08 m. Pit X, from a plundered JNG grave. (B.30873.)
- U.19616 Stone bowl, white limestone, Type JN.24, ht. 0.08 m., diam. 0.22 m. JNG/244. (B.30816.)
- U.19617 Stone bowl, diorite, Type JN.8, ht. 0.08 m., diam. 0.13 m. Pit X, from a plundered JNG grave.
- U.19618 Stone vase, white calcite, Type JN.51, ht. 0.24 m., diam. 0.135 m. JNG/246. (B.19910.)
- U.19619 Stone vase, calcite, miniature, ht. 0.065 m., diam. 0.04 m. JNG/245. (L.BM.123611.)
- U.19620 Stone vase, white calcite, Type JN.57, ht. 0.045 m., diam. 0.05 m. JNG/245. (L.)
- U.19621 Stone bowl, diorite, Type JN.27, ht. 0.10 m., diam. 0.16 m. JNG/245. (B.20562.)
- U.19622 Stone vase, white calcite, Type JN.57, ht. 0.10 m., diam. 0.14 m. JNG/245.
- U.19623 Stone vase, white calcite, Type JN.59, ht. 0.04 m., diam. 0.065 m. JNG/242. (B.30779.)
- U.19624 Stone bowl, diorite, ht. 0.065 m., diam. 0.155 m. JNG/242. (L.)
- U.19625 Stone vase, calcite, Type JN.57, ht. 0.17 m., diam. 0.16 m. JNG/242. (B.30878.)
- U.19626 Stone bowl, diorite, Type JN.14, ht. 0.035 m., diam. 0.15 m. JNG/242. (P.)
- U.19627 Stone bowl, diorite, Type JN.8, ht. 0.11 m., diam. 0.15 m. JNG/242. (B.30825.)
- U.19628 Stone bowl, diorite, ht. 0.13 m., diam. 0.20 m. Pit X, from a plundered JNG grave. (P.35.1.562.)
- U.19629 Stone bowl, diorite, Type JN.40, ht. 0.09 m., diam. 0.11 m. JNG/242. (B.30784.)
- U.19630 Stone bowl, white limestone, Type JN.8, ht. 0.09 m., diam. 0.115 m. Pit X, from a plundered JNG grave. (B.19866.)
- U.19631 Stone bowl, diorite, Type JN.30, ht. 0.10 m., diam. 0.14 m. Pit X, from a plundered JNG grave. (L.)
- U.19632 Stone bowl, white limestone, Type JN.12, ht. 0.11 m., diam. 0.23 m. JNG/241. (B.30813.)
- U.19633 Stone bowl, white limestone, Type JN.24, ht. 0.11 m., diam. 0.23 m. JNG/241. (P.35.1.529.)
- U.19634 Stone bowl, white limestone, Type JN.24, ht. 0.12 m., diam. 0.20 m. Pit X, from a plundered JNG grave. (B.30801.)
- U.19635 Stone bowl, diorite, Type JN.1, ht. 0.10 m., diam. 0.21 m. JNG/243. (B.30826.)
- U.19636 Stone bowl, white limestone, Type JN.24, ht. 0.11 m., diam. 0.18 m. JNG/243. (B.30741.)
- U.19637 Stone bowl, diorite, Type JN.4, fragmentary. JNG/243. (B.30772.)
- U.19638 Stone bowl, white limestone, Type JN.24, fragmentary. Pit X, from a plundered JNG grave.
- U.19640 Three stone vases, alabaster, Type JN.59, hts. 0.045 m., 0.04 m., and 0.035 m. respectively. JNG/246. (L.BM.123610; P.35.1.184.)
- U.19641 Stone bowl, diorite, Type JN.12, ht. 0.035 m., diam. 0.095 m. JNG/246. (P.35.1.582.)
- U.19642 Stone bowl, diorite, Type JN.31, ht. 0.10 m., diam. 0.11 m. JNG/246.
- U.19643 Stone lamp, alabaster, ht. 0.045 m., l. 0.205 m., width 0.06 m. JNG/247. (B.19843.)
- U.19644 Stone bowl, diorite, Type JN.13, ht. 0.07 m., diam. 0.18 m. JNG/250.
- U.19645 Stone bowl, diorite, Type JN.9, ht. 0.12 m., diam. 0.14 m. JNG/250. (B.)
- U.19646 Stone bowl, diorite, Type JN.30, ht. 0.09 m., diam. 0.14 m. JNG/249. (L.)
- U.19647 Stone vase, white calcite, Type JN.59, ht. 0.04 m., diam. 0.035 m. JNG/249. (B.30806.)
- U.19648 Stone bowl, white limestone, Type JN.10, ht. 0.09 m., diam. 0.145 m. JNG/249. (B.20574.)
- U.19649 Stone vase, alabaster, Type JN.59, ht. 0.065 m. diam. 0.08 m. JNG/248.
- U.19650 Stone bowl, diorite, Type JN.24, ht. 0.11 m., diam. 0.23 m. JNG/248. (L.)
- U.19651 Stone bowl, diorite, Type JN.24, ht. 0.065 m., diam. 0.11 m. JNG/248.
- U.19652 Stone bowl, white limestone, Type JN.35, ht. 0.09 m., diam. 0.27 m. Pit X, from a plundered JNG grave.
- U.19653 Stone bowl, diorite, Type JN.32, ht. 0.085 m., diam. 0.10 m. JNG/248. (P.35.1.572.)

- U.19654 Stone bowl, diorite, Type JN.12, ht. 0.075 m., diam. 0.20 m. JNG/251. (P.35.1.591.)
- U.19655 Stone vase, alabaster, Type JN.57, ht. 0.10 m., diam. 0.13 m. JNG/251. (B.30777.)
- U.19656 Stone bowl, basic diorite, Type JN.41, ht. 0.10 m., diam. 0.18 m. Pit X, from a plundered JNG grave. (P.35.1.218.)
- U.19657 Stone bowl, diorite, Type JN.4, ht. 0.11 m., diam. 0.12 m. Pit X, from a plundered JNG grave. (L.)
- U.19658 Stone bowl, basic diorite, Type JN.24, ht. 0.085 m., diam. 0.115 m. JNG/258. (B.30793.)
- U.19659 Stone bowl, diorite, Type JN.1, ht. 0.09 m., diam. 0.15 m. JNG/258.
- U.19670 Stone bowl, diorite, Type JN.28, ht. 0.11 m., diam. 0.16 m. Pit X, from a plundered JNG grave. (B.30717.)
- U.19671 Stone vase, white calcite, ht. 0.09 m., diam. 0.145 m. Pit X, from a plundered JNG grave. (P.35.1.522.)
- U.19672 Stone bowl, white limestone, Type JN.30, ht. 0.085 m., diam. 0.13 m. Pit X, from a plundered JNG grave.
- U.19673 Stone bowl, basic diorite, Type JN.12, ht. 0.07 m., diam. 0.15 m. Pit X, from a plundered JNG grave. (B.30869.)
- U.19674 Stone bowl, white limestone, Type JN.10, ht. 0.07 m., diam. 0.14 m. Pit X, from a plundered JNG grave. (L.)
- U.19675 Stone vase, white limestone, Type JN.57, ht. 0.085 m., diam. 0.105 m. Pit X, from a plundered JNG grave.
- U.19676 Stone bowl, white limestone, Type JN.25, ht. 0.065 m., diam. 0.21 m. Pit X, from a plundered JNG grave. (P.35.1.534.)
- U.19677 Stone bowl, diorite, Type JN.24, ht. 0.09 m., diam. 0.175 m. Pit X, from a plundered JNG grave. (L.)
- U.19678 Stone bowl, white limestone, Type JN.8, ht. 0.06 m., diam. 0.105 m. Pit X, from a plundered JNG grave. (L.)
- U.19679 Stone bowl, white limestone, Type JN.35, ht. 0.085 m., diam. 0.17 m. Pit X, from a plundered JNG grave. (B.20600.)
- U.19680 Stone bowl, limestone, Type JN.20, ht. 0.06 m., diam. 0.105 m. JNG/251.
- U.19681 Stone bowl, white limestone, Type JN.24, ht. 0.075 m., diam. 0.18 m. JNG/251. (L.BM.)
- U.19682 Stone tumbler, diorite, Type JN.36, ht. 0.14 m., diam. 0.09 m. JNG/252. (P.35.1.570.)
- U.19683 Stone tumbler, diorite, Type JN.28, ht. 0.10 m., diam. 0.125 m. JNG/252. (P.)
- U.19684 Stone bowl, basic diorite, Type JN.52, diam. 0.29 m. JNG/252. (B.20553.)
- U.19685 Stone bowl, diorite, Type JN.8. JNG/252. (B.19960.)
- U.19686 Stone bowl, diorite, Type JN.22, ht. 0.045 m., diam. 0.105 m. JNG/253. (B.19886.)
- U.19687 Stone vase, white calcite, ht. 0.10 m., diam. 0.12 m. JNG/254. (B.30780.)
- U.19688 Stone bowl, diorite, Type JN.17, ht. 0.0275 m., diam. 0.095 m. JNG/254. (L.)
- U.19689 Stone bowl, white limestone, Type JN.24, ht. 0.11 m., diam. 0.17 m. JNG/254. (B.30877.)
- U.19690 Stone bowl, diorite, Type JN.10, ht. 0.11 m., diam. 0.14 m. Pit X, from a plundered JNG grave. (B.30898.)
- U.19692 Stone bowl, white limestone, Type JN.30, ht. 0.09 m., diam. 0.15 m. Pit X, from a plundered JNG grave. (B.30714.)
- U.19693 Stone bowl, basic diorite, Type JN.9, ht. 0.10 m., diam. 0.12 m. Pit X, from a plundered JNG grave. (B.36358.)
- U.19694 Stone bowl, diorite, Type JN.13, ht. 0.10 m., diam. 0.23 m. Pit X, from a plundered JNG grave. (L.)
- U.19695 Stone bowl, Type JN.13, ht. 0.08 m., diam. 0.025 m. Pit X, from a plundered JNG grave. (B.30830.)
- U.19696 Stone bowl, white limestone, Type JN.57, ht. 0.11 m., diam. 0.08 m. Pit X, from a plundered JNG grave. (B.30781.)
- U.19697 Stone bowl, white limestone, Type JN.15, ht. 0.09 m., diam. 0.24 m. Pit X, from a plundered JNG grave. (P.35.1.588.)
- U.19698 Stone bowl, fine white limestone, Type JN.62, ht. 0.045 m., diam. 0.10 m. Pit X, from a plundered JNG grave. (L.)
- U.19699 Stone bowl, fine white limestone, Type RC.48, ht. 0.04 m., diam. 0.10 m. Pit X, from a plundered grave of the PJ/B series. (L.)
- U.19700 Stone vase, alabaster, Type JN.57, ht. 0.10 m., diam. 0.17 m. JNG/255. (L.BM.123560.)
- U.19701 Stone bowl, diorite, Type JN.4, ht. 0.10 m., diam. 0.13 m. JNG/255. (L.)
- U.19702 Stone vase, diorite, fragmentary. JNG/255. (L.)
- U.19703 Stone bowl, diorite, Type JN.24. JNG/255. (B.30736.)
- U.19704 Stone bowl, limestone, Type JN.18, ht. 0.06 m., diam. 0.11 m. JNG/259. (B.30858.)

- U.19705 Stone bowl, limestone, Type JN.24, ht. 0.08 m., diam. 0.13 m. JNG/259. (B.30701.)
- U.19706 Stone bowl, fine white limestone, Type JN.8, ht. 0.11 m., diam. 0.12 m. JNG/258. (B.30889.)
- U.19707 Stone bowl, white limestone, Type JN.24, ht. 0.09 m., diam. 0.16 m. JNG/258. (P.35.1.607.)
- U.19708 Stone bowl, limestone, Type JN.12, ht. 0.05 m., diam. 0.21 m. Pit X, from a plundered JNG grave. (B.30840.)
- U.19709 Stone bowl, coarse limestone, Type JN.20, ht. 0.075 m., diam. 0.14 m. Pit X, from a plundered JNG grave.
- U.19710 Stone bowl, coarse limestone, Type JN.18, ht. 0.075 m., diam. 0.18 m. Pit X, from a plundered JNG grave. (B.30767.)
- U.19711 Stone bowl, diorite, Type JN.27, ht. 0.135 m., diam. 0.20 m. Pit X, from a plundered JNG grave. (P.)
- U.19712 Stone bowl, coarse limestone, Type JN.20, ht. 0.03 m., diam. 0.105 m. Pit X, from a plundered JNG grave. (B.30705.)
- U.19713 Stone bowl, coarse limestone, Type JN.20, ht. 0.11 m., diam. 0.20 m. Pit X, from a plundered JNG grave. (B.30833.)
- U.19714 Stone bowl, diorite, Type JN.20, ht. 0.07 m., diam. 0.16 m. Pit X, from a plundered JNG grave. (B.19956.)
- U.19715 Stone bowl, diorite, Type JN.24, ht. 0.08 m., diam. 0.16 m. Pit X, from a plundered JNG grave. (P.)
- U.19716 Stone bowl, white limestone, Type JN.14, ht. 0.04 m., diam. 0.13 m. JNG/256. (B.19971.)
- U.19717 Stone bowl, diorite, Type JN.52, ht. 0.06 m., diam. 0.165 m. JNG/257. (B.)
- U.19718 Stone bowl, diorite, ht. 0.10 m., diam. 0.24 m. JNG/257.
- U.19719 Stone bowl, diorite, Type JN.20, ht. 0.06 m., diam. 0.135 m. JNG/257. (L.)
- U.19720 Stone bowl, basic diorite, Type JN.13, ht. 0.035 m., diam. 0.095 m. JNG/264. (B.19887.)
- U.19721 Stone bowl, diorite, Type JN.12, ht. 0.05 m., diam. 0.15 m. JNG/264. (L.)
- U.19722 Stone cup, white limestone, Type JN.40, ht. 0.06 m., diam. 0.09 m. JNG/264. (L.)
- U.19723 Stone bowl, coarse white limestone, Type JN.24, ht. 0.105 m., diam. 0.18 m. JNG/264. (B.30893.)
- U.19724 Stone cup, diorite, Type JN.29, ht. 0.08 m., diam. 0.095 m. JNG/265.
- U.19725 Stone bowl, limestone, Type JN.9, ht. 0.065 m., diam. 0.11 m. JNG/265. (B.19966.)
- U.19726 Stone bowl, diorite, Type JN.24, ht. 0.06 m., diam. 0.12 m. JNG/265. (B.19941.)
- U.19727 Stone vase, alabaster, Type JN.57, ht. 0.12 m., diam. 0.16 m. JNG/265. (B.30827.)
- U.19728 Stone bowl, limestone, Type JN.24, diam. 0.25 m. JNG/266. (B.30740.)
- U.19729 Stone vase, alabaster, Type JN.48, ht. 0.08 m., diam. 0.095 m. Pit X, from a plundered JNG grave. (B.30810.)
- U.19730 Stone bowl, diorite, Type JN.24, ht. 0.07 m., diam. 0.155 m. JNG/265. (P.35.1.589.)
- U.19731 Stone bowl, limestone, Type JN.24, ht. 0.06 m., diam. 0.15 m. JNG/266. (B.30731.)
- U.19732 Stone bowl, diorite, Type JN.16, ht. 0.03 m., diam. 0.07 m. Pit X, from a plundered JNG grave. (B.19932.)
- U.19733 Stone bowl, limestone, Type JN.4, ht. 0.09 m., diam. 0.135 m. JNG/267. (L.)
- U.19734 Stone bowl, diorite, Type JN.4, ht. 0.095 m., diam. 0.115 m. JNG/267. (P.35.1.571.)
- U.19735 Stone bowl, white limestone, Type JN.8, ht. 0.08 m., diam. 0.09 m. JNG/268. (P.35.1.595.)
- U.19736 Stone bowl, white limestone, Type JN.24, diam. 0.28 m. JNG/268. (B.30724.)
- U.19737 Stone tumbler, diorite, Type JN.39, ht. 0.115 m., diam. 0.115 m. JNG/269. (B.30812.)
- U.19738 Stone bowl, white limestone, Type JN.12, ht. 0.06 m., diam. 0.21 m. JNG/269. (B.30791.)
- U.19739 Stone bowl, diorite, Type JN.11, ht. 0.035 m., diam. 0.75 m. JNG/269. (B.19841.)
- U.19740 Stone bowl, diorite, Type JN.24, ht. 0.08 m., diam. 0.18 m. JNG/270. (L.)
- U.19741 Stone bowl, diorite, Type JN.28, ht. 0.09 m., diam. 0.15 m. JNG/270. (B.30818.)
- U.19742 Stone bowl, white limestone, Type JN.19, ht. 0.075 m., diam. 0.195 m. JNG/271. (B.30862.)
- U.19743 Stone bowl, coarse white limestone, Type JN.24, ht. 0.12 m. diam. 0.195 m. JNG/271. (B.30729.)
- U.19744 Lamp, alabaster, Type JN.64, l. 0.147 m., ht. 0.036 m. The outer surface is covered with knobs made by grooves deeply cut at right angles; at the handle end is an oryx head in relief. JNG/272. Pls. 31, 32. (P.35.1.43.)
- U.19745 Lamp, alabaster, in the form of a shell, the five projections serving as spouts; on the under side is a bat's head. V. p. 31. L. 0.095 m. JNG/272. Pl. 32. (B.19844.)
- U.19746 Stone bowl, diorite, Type JN.16, ht. 0.035 m., diam. 0.09 m. JNG/272. (L.)
- U.19747 Stone bowl, diorite, Type JN.16, diam. 0.075 m. JNG/272. (L.)
- U.19748 Stone bowl, diorite, Type JN.10, ht. 0.04 m., diam. 0.08 m. JNG/272. (P.35.1.214.)
- U.19749 Stone cup, diorite, Type JN.24, ht. 0.05 m., diam. 0.11 m. JNG/279. (B.30742.)
- U.19750 Stone vase, white calcite, Type JN.57, ht. 0.18 m., diam. 0.21 m. JNG/259. (L.)
- U.19751 Stone vase, white calcite, Type JN.56, ht. 0.05 m., diam. 0.06 m. Pit X, from a plundered JNG

- grave. (P.35.1.93.)
- U.19752 Stone bowl, diorite, Type JN.12, ht. 0.07 m., diam. 0.18 m. JNG/260. (B.30719.)
- U.19753 Stone vase, calcite, Type JN.57, ht. 0.11 m., diam. 0.16 m. JNG/260. (B.30846.)
- U.19754 Stone bowl, diorite, Type JN.28, ht. 0.105 m., diam. 0.165 m. Pit X, from a plundered JNG grave. (B.30720.)
- U.19755 Stone bowl, limestone, ht. 0.09 m., diam. 0.135 m. Pit X, from a plundered JNG grave. (B.30759.)
- U.19756 Stone bowl, diorite, Type JN.30, ht. 0.10 m., diam. 0.15 m. JNG/261. (L.)
- U.19757 Stone vase, white calcite, Type JN.59, ht. 0.09 m., diam. 0.105 m. JNG/261. (B.30811.)
- U.19758 Stone bowl, calcite, Type JN.57, ht. 0.06 m., diam. 0.15 m. JNG/261. (B.30843.)
- U.19759 Stone bowl, diorite, Type JN.8, ht. 0.11 m., diam. 0.20 m. Pit X, from a plundered JNG grave. (P.35.1.600.)
- U.19760 Stone bowl, diorite, Type JN.19, ht. 0.07 m., diam. 0.14 m. Pit X, from a plundered JNG grave. (B.30900.)
- U.19761 Stone bowl, diorite, Type JN.12, ht. 0.13 m., diam. 0.24 m. Pit X, from a plundered JNG grave. (L.)
- U.19762 Stone bowl, white limestone, Type JN.16, ht. 0.045 m., diam. 0.11 m. Pit X, from a plundered JNG grave. (B.30761.)
- U.19763 Stone bowl, white limestone, Type JN.8, ht. 0.15 m., diam. 0.19 m. JNG/262. (L.)
- U.19764 Stone bowl, white limestone, Type JN.48, ht. 0.04 m., diam. 0.05 m. Pit X, from a plundered JNG grave.
- U.19765 Stone bowl, diorite, Type JN.52, diam. 0.25 m. JNG/263. (B.30897.)
- U.19766 Stone bowl, white limestone, Type JN.15, ht. 0.09 m., diam. 0.195 m. JNG/280. (L.)
- U.19767 Stone bowl, coarse limestone, Type JN.44, ht. 0.21 m., diam. 0.30 m. JNG/280. (P.35.1.174.)
- U.19768 Stone bowl, basic diorite, Type JN.4, ht. 0.10 m., diam. 0.145 m. Pit X, from a plundered JNG grave. (B.19889.)
- U.19769 Stone bowl, white limestone, Type JN.15, diam. 0.23 m. Pit X, from a plundered JNG grave.
- U.19770 Lamp, alabaster, Type JN.64, ht. 0.045 m., max. diam. 0.145 m. JNG/273. Pl. 32. (L.)
- U.19771 Stone vase, alabaster, Type JN.57. JNG/273. (P.35.1.522.)
- U.19772 Stone bowl, diorite, Type JN.25, ht. 0.06 m., diam. 0.135 m. JNG/273. (L.)
- U.19773 Stone bowl, basic diorite, Type JN.24, ht. 0.055 m., diam. 0.14 m. JNG/279. (B.30743.)
- U.19774 Stone bowl, diorite, Type JN.24, ht. 0.09 m., diam. 0.18 m. JNG/279. (B.30785.)
- U.19776 Stone bowl, basic diorite, Type JN.4, ht. 0.10 m., diam. 0.12 m. JNG/278. (B.30723.)
- U.19777 Stone bowl, white limestone, Type JN.15, ht. 0.065 m., diam. 0.21 m. JNG/277a. (B.30860.)
- U.19778 Stone bowl, diorite, Type JN.24, ht. 0.09 m., diam. 0.18 m. Pit X, from a plundered JNG grave. (B.30822.)
- U.19779 Stone vase, alabaster, Type JN.57, ht. 0.12 m., diam. 0.15 m. JNG/278. (B.30879.)
- U.19780 Stone bowl, diorite, Type JN.4, ht. 0.07 m., diam. 0.16 m. Pit X, from a plundered JNG grave. (P.35.1.574.)
- U.19781 Stone bowl, white limestone, Type JN.12, ht. 0.075 m., diam. 0.25 m. Pit X, from a plundered JNG grave. (P.)
- U.19782 Stone bowl, white limestone, Type JN.24, ht. 0.06 m., diam. 0.145 m. JNG/281. (B.30697.)
- U.19783 Stone bowl, diorite, Type JN.12, ht. 0.10 m., diam. 0.29 m. JNG/281. (P.35.1.584.)
- U.19784 Stone bowl, limestone, Type JN.15, ht. 0.065 m., diam. 0.165 m. JNG/282. (P.)
- U.19785 Stone cup, white limestone, Type JN.24, ht. 0.065 m., diam. 0.13 m. JNG/282. (B.30908.)
- U.19786 Stone bowl, coarse white limestone, Type JN.8, ht. 0.12 m., diam. 0.14 m. JNG/284. (B.19948.)
- U.19787 Stone vase, white limestone, Type JN.48, ht. 0.025 m., diam. 0.035 m. JNG/288. (L.)
- U.19788 Stone cup, white limestone, Type JN.24, ht. 0.055 m., diam. 0.105 m. JNG/282. (B.20582.)
- U.19789 Stone cup, diorite, Type JN.24, ht. 0.04 m., diam. 0.07 m. JNG/283. (B.19931.)
- U.19790 Stone bowl, white limestone, Type JN.10, ht. 0.075 m., diam. 0.15 m. JNG/283. (B.30764.)
- U.19791 Stone bowl, limestone, Type JN.14, ht. 0.07 m., diam. 0.23 m. JNG/283. (B.30902.)
- U.19792 Stone bowl, white limestone, Type JN.20, ht. 0.045 m., diam. 0.12 m. JNG/283. (B.20569.)
- U.19793 Stone bowl, white limestone, Type JN.24, ht. 0.085 m., diam. 0.25 m. JNG/288. (B.30715.)
- U.19793a Stone bowl, white limestone, Type JN.14, ht. 0.05 m., diam. 0.21 m. JNG/283. (B.30866.)
- U.19794 Stone bowl, diorite, Type JN.20, ht. 0.10 m., diam. 0.15 m. JNG/288. (B.30875.)
- U.19795 Stone bowl, white limestone, Type JN.24, ht. 0.08 m., diam. 0.13 m. Pit X, from a plundered JNG grave. (B.19959.)
- U.19797 Stone bowl, veined limestone, Type JN.20, ht. 0.055 m., diam. 0.10 m. JNG/298. (P.35.1.555.)
- U.19798 Clay bowl of grey Uruk ware, Type JN.16, ht. 0.055 m., diam. 0.15 m. Pit X, from a plundered JNG grave.
- U.19799 Stone bowl, diorite, Type JN.5, ht. 0.065 m., diam. 0.12 m. Pit X, from a plundered JNG grave. (P.35.1.210.)

- U.19800 Stone bowl, limestone, Type JN.10, ht. 0.075 m., diam. 0.14 m. JNG/318. (B.30903.)
- U.19801 Stone bowl, diorite, Type JN.52, ht. 0.08 m., diam. 0.265 m. JNG/279a. (B.30814.)
- U.19802 Stone bowl, diorite, Type JN.41, ht. 0.05 m., diam. 0.115 m. JNG/279a. (B.30805.)
- U.19803 Stone bowl, limestone, Type JN.24, ht. 0.10 m., diam. 0.20 m. JNG/279a. (L.)
- U.19804 Stone bowl, limestone, Type JN.22, ht. 0.065 m., diam. 0.11 m. JNG/279a. (B.19854.)
- U.19805 Lamp, alabaster, l. 0.14 m., width 0.08 m., ht. 0.03 m. JNG/279a.
- U.19806 Stone bowl, limestone, Type JN.24, ht. 0.10 m., diam. 0.21 m. JNG/274.
- U.19807 Stone bowl, pink limestone, Type JN.48, ht. 0.04 m., diam. 0.045 m. JNG/274.
- U.19808 Stone bowl, pink limestone, Type JN.24, ht. 0.09 m., diam. 0.145 m. JNG/275. (B.30754.)
- U.19809 Stone bowl, white limestone, Type JN.24, ht. 0.10 m., diam. 0.14 m. JNG/275.
- U.19810 Stone bowl, white limestone, Type JN.24, ht. 0.08 m., diam. 0.165 m. JNG/275. (P.)
- U.19811 Stone bowl, diorite, Type JN.41, ht. 0.085 m., diam. 0.145 m. JNG/276. (B.19928.)
- U.19812 Stone bowl, white limestone, ht. 0.09 m., diam. 0.20 m. PJ/B.95b. (B.30749.)
- U.19813 Stone bowl, white limestone, ht. 0.11 m., diam. 0.24 m. PJ/B.95b. (P.35.1.594.)
- U.19814 Stone bowl, white limestone, Type JN.24, ht. 0.13 m., diam. 0.32 m. JNG/285. (B.30872.)
- U.19815 Stone bowl, diorite, Type JN.1, ht. 0.075 m., diam. 0.185 m. Broken and rivetted in antiquity. JNG/285. (B.30712.)
- U.19816 Stone bowl, white limestone, Type JN.18, ht. 0.055 m., diam. 0.145 m. JNG/286. (L.)
- U.19817 Stone bowl, white limestone, Type JN.52, ht. 0.06 m., diam. 0.16 m. JNG/286. (B.20597.)
- U.19818 Stone bowl, white limestone, Type JN.15, ht. 0.06 m., diam. 0.20 m. Pit X, from a plundered JNG grave. (B.30739.)
- U.19819 Stone bowl, diorite, Type JN.9, ht. 0.06 m., diam. 0.16 m. JNG/287. (P.35.1.601.)
- U.19820 Stone bowl, diorite, Type JN.17, ht. 0.04 m., diam. 0.12 m. JNG/287. (B.19849.)
- U.19821 Stone bowl, white limestone, Type JN.16, ht. 0.06 m., diam. 0.15 m. JNG/287. (B.30868.)
- U.19822 Stone bowl, white limestone, Type JN.24, ht. 0.23 m., diam. 0.30 m. JNG/287.
- U.19823 Stone bowl, white limestone, Type JN.48, ht. 0.06 m., diam. 0.07 m. JNG/287. (L.)
- U.19824 Stone bowl, white limestone, Type JN.5, ht. 0.08 m., diam. 0.13 m. JNG/287. (B.30820.)
- U.19825 Stone bowl, limestone, Type JN.24, ht. 0.10 m., diam. 0.16 m. JNG/287. (B.30713.)
- U.19826 Stone bowl, white limestone, Type JN.15, ht. 0.07 m., diam. 0.18 m. Pit X, from a plundered JNG grave.
- U.19828 Stone bowl, white calcite, Type JN.57, ht. 0.12 m., diam. 0.125 m. JNG/289. (P.35.1.179.)
- U.19829 Stone bowl, basic diorite, Type JN.12, ht. 0.07 m., diam. 0.15 m. JNG/289. (B.)
- U.19830 Stone bowl, basic diorite, Type JN.43, ht. 0.06 m., diam. 0.10 m. JNG/289. (B.19930.)
- U.19831 Stone bowl, white limestone, Type JN.12, ht. 0.06 m., diam. 0.11 m. JNG/289. (B.19942.)
- U.19832 Stone bowl, white limestone, Type JN.41. JNG/289. (B.30803.)
- U.19833 Stone bowl, basic diorite, Type JN.12, ht. 0.05 m., diam. 0.135 m. JNG/290. (B.30854.)
- U.19834 Stone bowl, basic diorite, Type JN.24, ht. 0.075 m. JNG/290. (B.19865.)
- U.19835 Stone bowl, white limestone, Type JN.12, ht. 0.05 m., diam. 0.125 m. JNG/290. (B.30758.)
- U.19836 Stone vase, white calcite, Type JN.57, ht. 0.13 m., diam. 0.17 m. JNG/290. (P.35.1.176.)
- U.19837 Stone bowl, coarse white limestone, Type JN.24, ht. 0.08 m., diam. 0.205 m. Pit X, from a plundered JNG grave. (B.20583.)
- U.19838 Stone bowl, coarse limestone, Type JN.19, ht. 0.07 m., diam. 0.22 m. JNG/291. (P.35.1.535.)
- U.19839 Stone bowl, coarse white limestone, Type JN.19, ht. 0.08 m., diam. 0.16 m. JNG/291. (B.30792.)
- U.19840 Stone bowl, white limestone, Type JN.19, ht. 0.09 m., diam. 0.15 m. Pit X, from a plundered JNG grave. (B.30834.)
- U.19841 Stone bowl, coarse white limestone, Type JN.47, ht. 0.07 m., diam. 0.18 m. Pit X, from a plundered JNG grave.
- U.19842 Stone bowl, basic diorite, Type JN.4, ht. 0.085 m., diam. 0.13 m. JNG/292. (P.35.1.605.)
- U.19843 Stone bowl, limestone, Type JN.52, ht. 0.24 m., diam. 0.20 m. JNG/292. (B.30819.)
- U.19844 Stone bowl, basic diorite, Type JN.24, ht. 0.12 m., diam. 0.20 m. JNG/292. (B.30788.)
- U.19845 Stone bowl, basic diorite, ht. 0.11 m., diam. 0.29 m. JNG/294. (P.35.1.71.)
- U.19846 Stone saucer, basic diorite, Type JN.14, ht. 0.02 m., diam. 0.07 m. A hole is pierced through the centre of the base and another through the side near the rim; cf. Fig. 12 (b). JNG/294. (B.20550.)
- U.19847 Stone bowl, white limestone, Type JN.41, ht. 0.15 m., diam. 0.22 m. JNG/296. (P.)
- U.19848 Stone cup, diorite, Type JN.32, ht. 0.05 m., diam. 0.04 m. JNG/298. (B.19952.)
- U.19849 Stone bowl, fine limestone, Type JN.32. Pit X, from a plundered JNG grave. (B.)
- U.19850 Beads; large rings, 6 of haematite and one of red stone. JNG/287. (P.35.1.79.)
- U.19851 Beads; large carnelian rings. JNG/283. (L.BM.)
- U.19852 Beads; small carnelian rings. JNG/277. (P.35.1.88.)

- U.19853 Beads; shell cylinders and large barrels or rings of shell and haematite. JNG/276. (P.35.1.69.)
- U.19854 Beads; large carnelian rings. JNG/287. Pl. 27.
- U.19855 Beads; shell cylinders, balls and rectangular spacers, and some small natural shells pierced for stringing. JNG/284. (B.20377.)
- U.19856 Beads; large carnelian rings. JNG/284. (B.20041.)
- U.19857 Beads; large carnelian rings. Pit X, from a plundered JNG grave. (P.35.1.83.)
- U.19858 Beads; very large haematite and pebble rings, shell tubes and shell oval beads laterally pierced, and some small natural shells pierced for stringing. JNG/256. (P.35.1.95.)
- U.19859 Beads; medium-sized carnelian rings (worn in two parallel strings). JNG/259. (P.35.1.90.)
- U.19860 Beads; small rings of carnelian and a few lapis-lazuli. JNG/285. (B.20068.)
- U.19861 Beads; carnelian rings and a few carnelian and lapis-lazuli cylinders. JNG/261. (P.35.1.74.)
- U.19862 Beads; carnelian cylinders and date-shaped and a few lapis-lazuli balls. JNG/279. (B.20053.)
- U.19863 Beads; carnelian rings. Pit X, from a plundered JNG grave. (B.20065.)
- U.19864 Beads; carnelian rings. JNG/266. (B.20040.)
- U.19865 Beads; carnelian rings. JNG/269. (B.20063.)
- U.19866 Beads; lapis-lazuli, carnelian and silver large date-shaped, small lapis-lazuli and silver balls; re-strung in the original order. PJ/B.95.
- U.19867 Beads; large flat ovals of shell pierced at each end, shell cylinders, one haematite and one red stone ring, one calcite rhomboid. JNG/279. (B.20374.)
- U.19868 Beads; carnelian rings. JNG/253. (L.BM.)
- U.19869 Cylinder seal, shell, Vol. X, No. 91. PJ/B.93a. (B.18870.)
- U.19874 Bird's head in hard limestone, perhaps for a shell lamp, cf. Vol. II, Pl. 102a. Found low in the rubbish against the SW wall of the IIIrd Dynasty Temenos, l. 0.053 m. Pl. 44. (B.20078.)
- U.19875 Copper fish-hook, barbed, and the end of the shaft flattened for tying, l. 0.046 m., width 0.025 m. JNG/269. Pl. 30. (L.BM.123567.)
- U.19877 Stone bowl, white limestone, Type JN.27, ht. 0.17 m., diam. 0.23 m. JNG/298. (L.)
- U.19878 Stone bowl, white limestone, Type JN.22, ht. 0.075 m., diam. 0.175 m. JNG/298. (B.30876.)
- U.19879 Stone cup, diorite, Type JN.19, ht. 0.05 m., diam. 0.10 m. JNG/298. (B.19933.)
- U.19880 Stone bowl, white limestone, Type JN.28, ht. 0.12 m., diam. 0.21 m. JNG/296. (B.30732.)
- U.19881 Stone bowl, basic diorite, Type JN.15, ht. 0.05 m., diam. 0.135 m. JNG/296. (L.)
- U.19882 Stone bowl, basic diorite, Type JN.4, ht. 0.05 m., diam. 0.09 m. JNG/296. (B.20592.)
- U.19883 Stone bowl, white calcite, Type JN.9, ht. 0.095 m., diam. 0.135 m. JNG/296. (B.20589.)
- U.19884 Stone bowl, diorite, Type JN.8, ht. 0.08 m., diam. 0.11 m. JNG/296. (P.35.1.211.)
- U.19885 Lamp, white limestone; a hemispherical bowl ht. 0.07 m., diam. 0.17 m., having on one side by the rim a short ledge handle, opposite to this a short trough spout and on either side a double trough spout; round the outside is a band of raised square dots. JNG/210. Pl. 32. (B.19872.)
- U.19886 Stone bowl, diorite, Type JN.16, ht. 0.03 m., diam. 0.04 m. JNG/296.
- U.19887 Stone bowl, white calcite, Type JN.48, ht. 0.065 m., diam. 0.065 m. JNG/296. (B.30776.)
- U.19888 Stone bowl, diorite, Type JN.15, ht. 0.05 m., diam. 0.12 m. JNG/300. (L.)
- U.19889 Stone bowl, diorite, Type JN.28, ht. 0.125 m., diam. 0.20 m. JNG/300. (L.BM.)
- U.19890 Stone bowl, white limestone, Type JN.9, ht. 0.10 m., diam. 0.17 m. JNG/301. (P.35.1.599.)
- U.19891 Stone bowl, diorite, Type JN.52, ht. 0.08 m., diam. 0.20 m. JNG/302. (P.35.1.579.)
- U.19892 Stone bowl, coarse limestone, Type JN.15, ht. 0.12 m., diam. 0.26 m. JNG/314. (B.30738.)
- U.19893 Stone bowl, coarse limestone, Type JN.30, ht. 0.13 m., diam. 0.23 m. Pit X, from a plundered JNG grave.
- U.19894 Stone bowl, coarse limestone, Type JN.15, ht. 0.13 m., diam. 0.19 m. Pit X, from a plundered JNG grave. (B.30848.)
- U.19895 Stone bowl, fine limestone, Type JN.8, ht. 0.09 m., diam. 0.11 m. Pit X, from a plundered JNG grave. (B.30698.)
- U.19896 Stone bowl, limestone, Type JN.15, ht. 0.07 m., diam. 0.16 m. Pit X, from a plundered JNG grave.
- U.19897 Stone vase, alabaster, Type JN.59, ht. 0.045 m., diam. 0.055 m. Pit X, from a plundered JNG grave. (P.35.1.182.)
- U.19898 Stone bowl, basic diorite, Type JN.4, ht. 0.12 m., diam. 0.20 m. JNG/305. (B.19858.)
- U.19899 Stone bowl, white limestone, Type JN.10, ht. 0.06 m., diam. 0.12 m. JNG/305. (B.19860.)
- U.19900 Stone bowl, light pink limestone, Type JN.24, ht. 0.075 m., diam. 0.105 m. JNG/305. (P.35.1.550.)
- U.19901 Stone bowl, white limestone, Type JN.52, ht. 0.055 m., diam. 0.14 m. JNG/305. (B.19962.)
- U.19902 Stone bowl, basic diorite, Type JN.1, ht. 0.035 m., diam. 0.09 m. Pit X, from a plundered JNG grave. (B.20606.)
- U.19903 Stone bowl, limestone, Type JN.24, ht. 0.06 m., diam. 0.105 m. Pit X, from a plundered JNG



- grave. (B.20595.)
- U.19904 Stone tumbler, white limestone, Type JN.39, ht. 0.13 m., diam. 0.155 m. Pit X, from a plundered JNG grave.
- U.19905 Stone bowl, white limestone, Type JN.9, ht. 0.15 m., diam. 0.255 m. Pit X, from a plundered JNG grave. (B.30890.)
- U.19906 Stone vase, limestone, Type JN.48, ht. 0.045 m., diam. 0.04 m. JNG/299. (L.)
- U.19907 Stone tumbler, diorite, Type JN.35, ht. 0.145 m., diam. 0.075 m. JNG/306. (B.19949.)
- U.19908 Stone bowl, light pink limestone, Type JN.24, ht. 0.20 m., diam. 0.38 m. JNG/306. (B.30817.)
- U.19909 Stone bowl, white limestone, Type JN.24, ht. 0.05 m., diam. 0.145 m. JNG/306. (P.35.1.587.)
- U.19910 Stone bowl, limestone, Type JN.24, ht. 0.10 m., diam. 0.175 m. JNG/307. (B.30757.)
- U.19911 Stone vase, alabaster, Type JN.57, ht. 0.11 m., diam. 0.145 m. JNG/308. (L.)
- U.19912 Stone bowl, diorite, Type JN.4, ht. 0.11 m., fragmentary. JNG/306. (P.35.1.590.)
- U.19914 Stone bowl, diorite, Type JN.20, ht. 0.04 m., diam. 0.12 m. JNG/309. (L.)
- U.19915 Stone bowl, white limestone, Type JN.23, ht. 0.08 m., diam. 0.25 m. JNG/309. (B.30880.)
- U.19916 Stone bowl, white limestone, Type JN.23, ht. 0.09 m., diam. 0.20 m. JNG/309. (B.30882.)
- U.19917 Stone bowl, basic diorite, Type JN.8, ht. 0.10 m., diam. 0.12 m. JNG/310. (P.35.1.209.)
- U.19918 Stone bowl, white limestone, Type JN.20, ht. 0.07 m., diam. 0.15 m. JNG/309. (B.30755.)
- U.19919 Stone bowl, white limestone, Type JN.20. JNG/309. (B.30756.)
- U.19920 Stone bowl, white limestone, Type JN.23, ht. 0.075 m., diam. 0.19 m. JNG/311. (B.30867.)
- U.19921 Stone bowl, white limestone, Type JN.20, ht. 0.05 m., diam. 0.125 m. JNG/311. (B.19885.)
- U.19922 Stone bowl, white limestone, Type JN.20, ht. 0.055 m., diam. 0.115 m. JNG/311. (B.308522.)
- U.19923 Stone pot, limestone, Type JN.32, ht. 0.07 m., diam. 0.10 m. Pit X, from a plundered JNG grave. (B.20591.)
- U.19924 Stone bowl, white calcite, Type JN.9, ht. 0.07 m., diam. 0.145 m. JNG/302. (B.30821.)
- U.19925 Stone vase, white calcite, Type JN.57, ht. 0.12 m., diam. 0.18 m. JNG/302. (P.35.1.548.)
- U.19926 Stone bowl, white limestone, Type JN.17, ht. 0.05 m., diam. 0.14 m. JNG/303.
- U.19927 Stone bowl, basic diorite, Type JN.9, ht. 0.11 m., diam. 0.15 m. Pit X, from a plundered JNG grave. (B.30722.)
- U.19928 Stone bowl, coarse limestone, Type JN.16, ht. 0.045 m., diam. 0.115 m. Pit X, from a plundered JNG grave. (B.19938.)
- U.19929 Stone bowl, basic diorite, Type JN.7, ht. 0.09 m., diam. 0.22 m. Pit X, from a plundered JNG grave. (P.35.1.586.)
- U.19930 Stone bowl, white limestone, Type JN.14, ht. 0.055 m., diam. 0.23 m. JNG/314. (B.30800.)
- U.19931 Stone bowl, white limestone, Type JN.14, JNG/314.
- U.19932 Stone bowl, limestone, Type JN.15, ht. 0.09 m., diam. 0.24 m. Pit X, from a plundered JNG grave. (B.30815.)
- U.19933 Stone bowl, white limestone, Type JN.15, ht. 0.08 m., diam. 0.16 m. Pit X, from a plundered JNG grave. (L.)
- U.19934 Stone bowl, basic diorite, Type JN.4, ht. 0.10 m., diam. 0.15 m. Pit X, from a plundered JNG grave. (B.19856.)
- U.19935 Stone bowl, diorite, Type JN.7, ht. 0.65 m., diam. 0.115 m. JNG/312. (P.35.1.221.)
- U.19936 Stone bowl, limestone, Type JN.22, ht. 0.06 m., diam. 0.115 m. JNG/313.
- U.19937 Copper spoon, with long slender handle and flat blade, total l. 0.20 m., blade 0.04 m. x 0.035 m. JNG/305. (B.20226.)
- U.19938 Stone bowl, diorite, Type JN.20, ht. 0.045 m., diam. 0.105 m. JNG/315. (P.35.1.222.)
- U.19939 Stone bowl, white limestone, Type JN.20, ht. 0.05 m., diam. 0.125 m. JNG/315. (B.30859.)
- U.19940 Stone bowl, white limestone, Type JN.24, ht. 0.13 m., diam. 0.26 m. JNG/316. (B.30824.)
- U.19941 Stone cup, diorite, Type JN.7, ht. 0.08 m., diam. 0.125 m. Pit X, from a plundered JNG grave. (B.30901.)
- U.19942 Beads; small carnelian rings, a few very small and one large shell ring. JNG/311. (L.BM.)
- U.19943 Beads; carnelian rings. JNG/300.
- U.19944 Beads; carnelian cylinders and one long faceted double conoid. JNG/298. (B.20046.)
- U.19945 Beads; carnelian and lapis lazuli rings and cylinders and two large chalcedony flattened ovals. JNG/296. (P.35.1.71.)
- U.19946 Beads; carnelian rings. JNG/305. (L.BM.)
- U.19947 Silver pendant, a disk of sheet metal to which are soldered cones of coiled wire; diam. 0.045 m. PJ/B.95. Pl. 30. (P.)
- U.19948 Stone bowl, white limestone, Type JN.15, ht. 0.06 m., diam. 0.18 m. Pit X, from a plundered JNG grave. (B.30718.)
- U.19949 Stone bowl, limestone, ht. 0.04 m., diam. 0.10 m. JNG/313a. (B.30730.)
- U.19950 Beads; carnelian, shell and a few lapis lazuli rings, large rings of shell and haematite and long

- flat ovals of shell pierced at each end. JNG/309. (L.BM.)
- U.19951 Beads; carnelian tubes, lapsi lazuli tubes and rings. JNG/301. (P.35.1.93.)
- U.19952 Stone bowl, diorite, Type JN.15, ht. 0.055 m., diam. 0.16 m. Pit X, from a plundered JNG grave. (P.35.1.217.)
- U.19953 Stone bowl, diorite, Type JN.4, diam. 0.10 m. Pit X, from a plundered JNG grave. (B.30896.)
- U.19954 Stone bowl, basic diorite, Type JN.14, ht. 0.05 m., diam. 0.18 m. Pit X, from a plundered JNG grave. (B.30768.)
- U.19955 Stone bowl, diorite, Type JN.4. JNG/318.
- U.19956 Stone bowl, coarse limestone, Type JN.24, ht. 0.12 m., diam. 0.29 m. JNG/323. (B.30769.)
- U.19959 Stone bowl, diorite, Type JN.9, ht. 0.08 m., diam. 0.115 m. JNG/323. (B.30748.)
- U.19960 Stone bowl, diorite, Type JN.20, ht. 0.075 m., diam. 0.15 m. JNG/325. (L.)
- U.19961 Stone bowl, diorite, Type JN.52, ht. 0.10 m., diam. 0.12 m. JNG/325. Pl. 32. (L.BM.123605.)
- U.19962 Stone bowl, limestone, Type JN.24, ht. 0.075 m., diam. 0.15 m. JNG/319. (P.35.1.540.)
- U.19963 Stone tumbler, diorite, Type JN.35, ht. 0.175 m., diam. 0.10 m. JNG/320. Pl. 32. (P.35.1.201.)
- U.19964 Stone bowl, limestone, Type JN.14, ht. 0.09 m., diam. 0.27 m. JNG/321. (L.)
- U.19965 Stone bowl, limestone, Type JN.20, ht. 0.065 m., diam. 0.155 m. JNG/321. (B.30762.)
- U.19966 Stone bowl, limestone, Type JN.24, ht. 0.12 m., diam. 0.285 m. JNG/321. (L.BM.123602.)
- U.19967 Stone pot, limestone, Type JN.44, ht. 0.15 m., diam. 0.21 m. JNG/321. (B.19912.)
- U.19968 Stone bowl, diorite, Type JN. 20, ht. 0.06 m., diam. 0.11 m. Pit X, from a plundered JNG grave. (P.35.1.575.)
- U.19969 Stone pot, limestone, Type JN.24, ht. 0.06 m., diam. 0.10 m. JNG/322. (B.20567.)
- U.19970 Stone bowl, pinkish limestone, Type JN.4, ht. 0.08 m., diam. 0.13 m. JNG/324. (B.19953.)
- U.19971 Beads; a few minute tubes of green-glazed frit. JNG/295. (B.20341.)
- U.19972 Beads; small carnelian rings. JNG/322. (P.35.1.89.)
- U.19973 Beads; carnelian rings, long shell tubes (decayed) and shell and haematite rings. JNG/323.
- U.19974 Stamp seal, steatite; circular, convex above; Vol. X, No. 5. JNG/324. (P.35.1.18.)
- U.19975 Stamp seal, steatite, circular; Vol. X, No. 6. JNG/324. (B.18876.)
- U.19976 Terra-cotta figurine, fragment of; nude female figure modelled in greenish drab clay with details in black paint; the arms and the body below the waist missing. Ht. 0.07 m. Pit X, in the rubbish stratum below the JNG graves. Pl. 21. (L.BM.123591.)
- U.19979 Clay vase, Type JN.38, ht. 0.20 m., painted red all over. JNG/326. (P.35.1.235.)
- U.19980 Clay vase, Type JN.48, ht. 0.20 m., painted red and burnished. JNG/317. Pl. 25. (P.)
- U.19981 Clay vase, Type JN.38, ht. 0.085 m., painted red and burnished. JNG/317. Pl. 25. (L.)
- U.19982 Clay vase, Type aU.31, ht. 0.09 m., of buff ware with design in black paint. Pit X, Grave WW. (B.19917.)
- U.19983 Clay vase, Type aU.21, ht. 0.09 m., diam. 0.15 m., of light drab clay with design in black paint. Pit X, Grave WW. (B.30752.)
- U.19984 Clay vase, Type JN.33 (imitation of stone type JN.57), ht. 0.065 m., of blackish grey ware, smother-kiln fired. Pit X, from a plundered JNG grave. (B.19879.)
- U.19985 Clay vase, Type JN.33 (imitation of stone type JN.57), ht. 0.065 m., of very smooth greenish drab ware. JNG/274. Pl. 25. (L.)
- U.19986 Clay vase, Type JN.47, ht. 0.39 m., diam. 0.38 m., painted all over. Pit X, from a plundered JNG grave. Pl. 26. (L.)
- U.19988 Stone bowl, diorite, Type JN.24, ht. 0.07 m., diam. 0.14 m. JNG/327. (B.30725.)
- U.19989 Stone bowl, white limestone, Type JN.4, ht. 0.12 m., diam. 0.12 m. Pit X, from a plundered JNG grave. (B.20610.)
- U.19990 Stone bowl, white limestone, Type JN.12, ht. 0.15 m., diam. 0.15 m. JNG/328. (L.BM.)
- U.19991 Stone bowl, diorite, Type JN.8, ht. 0.12 m., diam. 0.16 m. JNG/329. (L.BM.)
- U.19992 Stone bowl, diorite, Type JN.12, ht. 0.045 m., diam. 0.10 m. JNG/331. (B.19950.)
- U.19993 Stone bowl, white limestone, Type JN.19, ht. 0.055 m., diam. 0.115 m. JNG/331. (B.)
- U.19994 Stone bowl, limestone, Type JN.20, ht. 0.055 m., diam. 0.135 m. JNG/330. (B.19970.)
- U.19995 Stone bowl, diorite, Type JN.24, ht. 0.14 m. JNG/330. (B.30747.)
- U.19996 Stone bowl, white limestone, Type JN.24, ht. 0.12 m., diam. 0.18 m. JNG/331.
- U.19997 Stone bowl, white limestone, Type JN.22, ht. 0.05 m., diam. 0.13 m. JNG/331. (P.35.1.555.)
- U.19998 Stone bowl, white limestone, Type JN.27, ht. 0.13 m., diam. 0.16 m. Pit X, from a plundered JNG grave. (L.)
- U.19999 Stone bowl, limestone, Type JN.4, ht. 0.045 m., diam. 0.085 m. Pit X, from a plundered JNG grave. (L.)
- U.20000 Stone cup, limestone, Type JN.40, ht. 0.06 m., diam. 0.065 m. Decorated on the outside with figures of two cows and a calf carved in relief. The surface of the stone has suffered from decay and the rim is worn. JNG/330. Pl. 31. V. p. 31. (L.BM.123563.)

- U.20001 Stone bowl, limestone, Type JN.18, ht. 0.065 m., diam. 0.15 m. JNG/335. (B.20575.)
- U.20002 Stone bowl, white limestone, Type JN.20, ht. 0.06 m., diam. 0.10 m. JNG/335. (P.35.1.92.)
- U.20003 Stone pot, basic diorite, Type JN.32, ht. 0.09 m., diam. 0.11 m. Pit X, from a plundered JNG grave. (B.19863.)
- U.20004 Stone bowl, limestone, Type JN.11, ht. 0.07 m., diam. 0.10 m. JNG/337. (B.20579.)
- U.20005 Stone bowl, diorite, Type JN.5, ht. 0.05 m., diam. 0.105 m. JNG/337. (B.20578.)
- U.20006 Stone bowl, limestone, Type JN.8, ht. 0.06 m., diam. 0.11 m. JNG/337.
- U.20007 Stone bowl, white limestone, Type JN.24, ht. 0.15 m., diam. 0.275 m. JNG/333. (L.BM.)
- U.20009 Stone bowl, white limestone, Type JN.15, ht. 0.07 m., diam. 0.25 m. Pit X, from a plundered JNG grave. (B.30841.)
- U.20010 Stone bowl, white limestone, Type JN.20, ht. 0.055 m., diam. 0.11 m. Pit X, from a plundered JNG grave. (B.19973.)
- U.20011 Stone bowl, white limestone, Type JN.17, ht. 0.05 m., diam. 0.14 m. Pit X, from a plundered JNG grave. (B.30709.)
- U.20012 Stone bowl, white limestone, Type JN.9, ht. 0.09 m., diam. 0.135 m. JNG/338. (L.)
- U.20013 Stone bowl, white limestone, Type JN.15, ht. 0.065 m., diam. 0.18 m. JNG/338. (B.19963.)
- U.20014 Stone bowl, white limestone, Type JN.24, ht. 0.075 m., diam. 0.14 m. JNG/338. (L.)
- U.20015 Stone bowl, diorite, Type JN.14, ht. 0.03 m., diam. 0.10 m. JNG/338.
- U.20016 Stone bowl, diorite, Type JN.24, ht. 0.13 m., diam. 0.26 m. JNG/339. (B.20543.)
- U.20017 Stone bowl, white limestone, Type JN.16, ht. 0.05 m., diam. 0.135 m. JNG/340.
- U.20018 Stone cup, white limestone, Type JN.39, ht. 0.115 m., diam. 0.125 m. JNG/341. (B.20545.)
- U.20019 Stone cup, diorite, Type JN.39, ht. 0.11 m., diam. 0.115 m. JNG/341. (B.30710.)
- U.20020 Stone bowl, white limestone, Type JN.17, ht. 0.05 m., diam. 0.145 m. JNG/342. (B.30899.)
- U.20021 Stone bowl, white limestone, Type JN.24, ht. 0.06 m., diam. 0.14 m. JNG/342.
- U.20022 Stone bowl, pinkish white limestone, Type JN.16, ht. 0.045 m., diam. 0.14 m. JNG/342. (P.)
- U.20023 Stone bowl, diorite, Type JN.17, ht. 0.035 m., diam. 0.09 m. JNG/343. (L.)
- U.20024 Clay vase, Type JN.48, ht. 0.13 m.; the lower part of the body is plain bright red, on the shoulders are panels alternately red with chocolate borders and buff with geometrical designs in black paint. JNG/346. Pl. 26. (B.19823.)
- U.20025 Clay vase, Type JN.62, ht. 0.13 m., painted with bands of geometric design; cf. U.20078. JNG/343. (P.35.1.233.)
- U.20026 Beads; shell rings, small natural shells pierced for stringing and natural "horn" shells. JNG/236. (B.20064.)
- U.20027 Beads; carnelian rings and a few lapis-lazuli ovals. JNG/337. (L.BM.)
- U.20028 Beads; carnelian date-shaped and long double conoids and lapis-lazuli cylinders and rings. JNG/330. (L.BM.)
- U.20029 Beads; small carnelian rings. JNG/335. (P.35.1.84.)
- U.20030 Beads; carnelian rings. JNG/334. (B.20355.)
- U.20031 Beads; carnelian rings, balls and cylinders and lapis-lazuli balls. Pit X, from a plundered JNG grave. (L.BM.) (P.35.1.87.)
- U.20032 Stone bowl, diorite, Type JN.4, ht. 0.13 m., diam. 0.14 m. JNG/347. (B.30874.)
- U.20033 Stone bowl, diorite, ht. 0.085 m. JNG/347. (B.30888.)
- U.20034 Stone bowl, diorite, Type JN.4, ht. 0.075 m., diam. 0.115 m. The base was made separately and stuck on. JNG/347. (B.20580.)
- U.20035 Beads; small carnelian and lapis-lazuli short cylinders, paste rings and one flat oval carnelian. JNG/325. (B.20337.)
- U.20036 Beads; small paste balls and date-shaped. JNG/239. (B.20326.)
- U.20037 Ear-rings, a pair; triple hoops of coiled wire, diam. 0.025 m. JNG/239. (B.20338.)
- U.20040 Clay vase, fragmentary, diam. 0.235 m., light drab clay on which a design in black paint of birds and plant forms. JNG/239. Pl. 26. (P.)
- U.20050 Cylinder seal, shell, Vol. X, No. 158. Pit X, loose in the soil, level uncertain. (B.18881.)
- U.20056 Table-top (?) of white limestone; a semi-circular slab diam. 0.34 m., radius 0.265 m., thickness 0.025 m.; near the edge are 3 small holes and near the centre 3 larger holes (all the holes are larger at the top). The small holes might be for attaching legs to the slab; the larger may be meant to receive round-bottomed stone vases such as Type JN.57. JNG/287. Pl. 33. (L.)
- U.20057 Clay vase, Type JN.60, ht. 0.045 m., black ware, smother-kiln fired. JNG/309. Pl. 25.
- U.20058 Stone vase, white limestone, Type JN.59, ht. 0.02 m., diam. 0.033 m. Pit X, from a plundered JNG grave. (B.20005.)
- U.20059 Stone vase, white calcite, Type JN.59, ht. 0.017 m., diam. 0.03 m. Pit X, from a plundered JNG grave. (P.35.1.186.)
- U.20060 Stone vase, alabaster, Type JN.59, ht. 0.025 m., diam. 0.04 m. Pit X, from a plundered JNG

- grave. (B.20007.)
- U.20061 Terra-cotta figurine of an animal, hand-modelled in greenish drab clay with details of eyes, collar etc, in black paint. Ht. 0.032 m. Pit X, in the lowest stratum above the Flood deposit. Pl. 21. (B.20027.)
- U.20062 Cylinder seal lapis lazuli, Vol. X, No. 61. Pit X, loose in the soil, level uncertain. (L.BM.123572.)
- U.20065 Beads; glazed frit balls, a carnelian ring and some natural shells. JNG/162. (B.20356.)
- U.20066 Beads; large flat ovals of shell pierced at each end, shell date-shaped and small natural shells pierced for stringing. JNG/243. (B.20375.)
- U.20071 Lead tray, with flat base and everted sides, circular; ht. 0.04 m., diam. 0.30 m. Metal Type JN.4. Pit X, from a plundered JNG grave. (P.35.1.230.)
- U.20072 Lead tray, circular, with flat base and everted sides, Metal Type JN.4; ht. 0.05 m., diam. 0.27 m. Pit X, from a plundered JNG grave. (B.20179.)
- U.20073 Lead tumblers, Metal Type JN.1, from various graves of the JNG series. (B.20181-94.)
- U.20074 Lead bowl, much distorted, Metal Type JN.6, ht. 0.05 m., diam. c. 0.12 m. Pit X, from a plundered JNG grave. (B.20180.)
- U.20075 Clay vase, Type 35, of grey ware, smother-kiln fired; in fragments. JNG/311. (P.35.1.608.)
- U.20076 Clay vase, Type JN.38, ht. 0.145 m., plain red-painted ware. Pit X, from a plundered JNG grave. (B.20009.)
- U.20077 Clay vase, Type JN.38, ht. 0.265 m., painted red and burnished. Pit X, from a plundered JNG grave. (B.)
- U.20078 Clay vase, fragmentary, the shoulder painted with panels alternatively of plain red and of drab body clay with geometrical designs in black. Pit X, from a plundered JNG grave. (L.BM.)
- U.20080 Disk of fine white limestone, diam. 0.048 m., flat below, convex above, pierced through the centre and having in the convex face 8 small round depressions as if for inlay; use uncertain. JNG/272. Pl. 16. (L.)
- U.20089 Beads; carnelian rings. JNG/251. (L.)
- U.20090 Stone bowl, white calcite, ht. 0.095 m., diam. 0.06 m. PJ/B.80. (B.9869.)
- U.20093 Obsidian 'nail' or stud; l. 0.043 m. Ur surface. Pl. 15.

## INDEX

The Text and Appendices I, II, and VI are indexed here. The remaining Appendices, being tabular in form, are entered by title only.

- A-anni-padda, 18, 40; inscription of, 40.  
 Adze, 78; bronze, 39; stone, 77.  
 Agate, beads, 32.  
 Agriculture, barley, 31; grain, 56; hoes, 10, 11, 14, 62, 66, 67, 69, 71; soil reclamation, 11; threshing implements, 14; tribulum, 14; vegetable matter, 56, 61; *v.* also Sickle.  
 Akkad, Sargon of, 16, 49 ff.  
 Alabaster, 26; animal reliefs, 42; beads, 32; boat relief, 42; statue of woman, 39; vase, 32, 85.  
 Aleppo, 78.  
 Al-Qazwīnī, on bitumen, 162.  
 Al 'Ubaid period (at Ur), 1-6; graves, 79, 80, 87-102; sherds from Pits A and B, 54; in Pit W, 76; in Pit Z, 80; *Period I*, 7-14; cemetery, 12; figurines, 13, 77; houses, 7-8; pottery, 7-8; stone objects, 8, 13, 14; *Period II*, 20-21; cemetery, 12, 20; occurrences of pot types, 146; *Period III*, 21-22; cemetery, 21-22, 33; occurrences of pot types, 146.  
 Al 'Ubaid (site), "apsu" drains at, 41; cemetery at, 36; First Dynasty temple at, 38.  
 Al-(zu?), inscribed plaque of, 47.  
 Amazonite, beads, 8, 67; from Transbaikalia, 8.  
 Amulets, 13; bird, 67; bull, 44, 80; calf, 43; celts as charms, 14; frogs, 39; human leg, 44; lion, 44; pebble, 67; tortoise, 44.  
 Anatolia, copper from, 165.  
 An-bu inscription, 45.  
 Andrae, Walter, 35.  
 Animal, alabaster, 42; bat, 31; al 'Ubaid, 8, 12; amulets, 39; boar, 31, 67; bones, 55, 56, 57, 59, 60, 64, 82, 89; bull, 43, 50, 61, 80; clay, 37, 67, 69, 71, 75, 76, 78, 80; demon, 51; dog, 43, 51; dragon, 50; Elamite, 51; fish, 42, 59; frog, 39; goat, 31, 41, 45; harnessed to model chariot, 78; ibex, 47, 51; lion, 32, 43; oxen, 31, 89; rams, 42; reliefs on stone vases, 31, 32; religious significance of various, 13; seals, 39, 43, 50, 71; shell, 39; sow, 42; stamp-seals, 43; teeth, 55; zoomorphic vase, 28; *v.* also Bird, Figurines.  
 Anu-Ziggurat at Warka, 12.  
 "Apsu" drains, 41-42.  
 Architecture, bricks in, 34; Building Strata A-H, 56-64; door with spears and rings, 45, 78; drains, 41, 56, 57; EH site, 40; hearth, 58, 69; at Mereijib, 83; mud and mortar walls, 56; Pit F, 56-64; Pits-K-L, 72-75; religious buildings on EH, 40; Sargonid, 50; stone, use of, 31; Tel Asmar, 40; temples, 31, 40; terracing in Pit G, 69-70; Warka, 28; wooden timbers in walls, 72; *v.* Brick, Cone-mosaic, Houses, Plano-convex bricks, Wall decoration, Ziggurat Terrace.  
 Armenian copper, 30, 165.  
 Army, 39.  
 Arrow heads, types of, 14; quartzite, 68.  
 Arsenic in copper, 30, 164-165.  
 Asphalt, lump from Pit K, 160; ring from Pit F, 158; *v.* also Bitumen.  
 Axe, 78; bronze, 39; clay, 9, 76; stone, 9, 21, 87.  
 Bad-tibira, 9.  
 Barley, 31.  
 Baskets, 56; imprints of, on asphalt 8, 69, 160, 162;  
 Bataafsche Petroleum Maatschappij, 164.  
 Bat-bowl, 31.  
 Battle-axe, 39.  
 Bead-maker, 79.  
 Beads, agate, 32; alabaster, 32; amazonite, 8, 67; bleached carnelian, 50; carnelian, 32, 43, 50, 61, 66; clay, 13, 54, 65, 66, 67, 71; crystal, 43, 66, 67; frit, 67; glaze, 30, 43, 66, 67, 88, gold, 39, 40; lapis lazuli, 32, 43, 56, 57, 61; limestone, 32; marble, 66; paste, 43, 67; pebble, 58; quartzite, 43; shell, 8, 20, 43, 61, 66, 76, 77, 87, 89, 92; silver, 81; steatite, 8, 20, 64, 65, 66, 67, 92; terracotta, 54.  
 "Bent-nails," 8, 11, 12, 64, 65, 66, 67, 68, 69, 71, 73, 74, 75, 84.  
 Bird, amulet, 67; bones of, in foundation deposits, 41; eagle, 50, 62; goose, 42; storm-bird, 50; vase in form of, 28; vulture, 13, 45, 47.  
 Bitumen, 8, 11, 12, 13, 28, 54, 69, 72, 81; chemical analysis, 158-164; composite frieze, 44; eyebrows of statue, 39; floors, 62; handle (?), 59; headdress on figurine, 92; jar lid, 64; lumps, 72, 73; mends for pottery, 58; "nails," 13; painted on pottery, 65; Persian author on, 162; plaster, 56; rug, 68, 158-164; setting for flints, 67; setting for quern, 58, 61; winning of, 159, 162.  
 Boar, stone, 31, 67.  
 Boat, limestone inlay pieces, 43; models, 41; relief, 42.  
 Bone, die, 44, 82; ox-rib knife, 82; pin, 20, 66, 99; sickle, 14; *v.* Animal, bones.  
 Bracelet, shell, 61; silver, 81.  
 Brak, eye-idols of, 43.  
 Bread, 45; pan, 57, 61.  
 Brick, box, 56, 58, 66; cement, 64, 66, 75; filling over Terrace, 72; flat, 2, 4, 29, 34, 60, 61, 64, 66, 69, 77, 80, 82, 83; foundation deposit, 56; hearth, 58; "herring bone" coursing of, 34, 58, 70, 82; kiln-fired crude, 7; models of, 34; plano-convex, 2, 4, 34-48, 54, 56, 57, 75, 80-82; "riemchen," 28, 29, 72; Sargonid, 50; sizes and periods, 29, 50; stamped, 34, 58, 85; triangular, 64; used in pottery kilns, 65-66.  
 British Museum Research Laboratories, 158, 165.  
 Bronze, adze, 39; axes, 39; daggers, 39; pin, 81.  
 Bull, calcite, 43; on seal, 50; shell amulet, 80.  
 Burials, *v.* Cemetery.  
 Burrows, E., 17, 18, 33, 45.  
 Bur-Sin, bricks of, 58, 85.  
 Bussokheir, 37.  
 Calcite, amulet, 43; bowl, 56, 63, 71; bull, 43; calf, 43; cup, 45; cylinder seal, 39; eye-idol, 43; human figure, 43; inscribed vases, 45, 51; mace-head, 51; miniature vase, 43, 71; moon-disk, 49; toilet pot, 43; vases, 32, 43, 45, 51, 56, 59.  
 Calf amulet, 43.  
 Campbell-Thompson, R., 11.  
 Carchemish, 27.  
 Carnelian, beads, 32, 43, 50, 61, 66; bleached, 50; Indus connections, 50; inlay, 32, 84.  
 Cattle, calf amulet, 43; on jar-sealings, 33; oxen hooves, 38; *v.* also Bull.  
 Celt, 10, 14, 61, 69, 84.  
 Cement, (at Ur) bricks at Mereijib, 29, 83, 158; chemical analysis of, 158; floor, 72; in Pit F kilns, 29, 64, 66; in Pit W, 75; in Royal Tombs, 29; (at Warka), 29.  
 Cemetery, al 'Ubaid I, 12; II, 12, 20; III, 21-22, 33; al 'Ubaid in Pit F, 87-102; Jamdat Nasr, 24-26, 30, 32, 33, 71, 103-126; military, 39, 78-79; in Pit F, 68-69; Royal, 2, 33, 38-39; R.C. period in Pit X, 127-133; Sargonid, 134, 145.  
 Chalcolithic culture, al 'Ubaid I as, 14; *v.* Copper.  
 Chariot, model, 28, 37, 75, 78; on seals, 50.  
 Charms, *v.* Amulets.  
 Chemical analyses, bitumen, 158-164; cement brick from Mereijib, 158; copper, 164; lead, 165; plaster from wall of Royal Tomb, 158; silt from Flood Deposit, 165.  
 Chthonic deities, 13 fn.  
 City-growth, 11.  
 Childe, V. Gordon, 9, 19.  
 Chisel, copper, 65; used in making stone bowl, 14 fn.  
 Chronology, general, 1 ff.  
 Clay, amulets, 13; balls, 75; bars or rods of uncertain use, 73, 75; basin for puddling, 66; beads, 13, 54, 65, 66, 67, 71; "bent nails," 8, 12, 64, 65, 66, 67, 68, 69, 71, 73, 74, 75, 84; coffins, 41; cones, 47, 75, 99; copies of inscriptions, 51; cylinders of Dungi, 41; die, 44; dishes on "Tables of God," 41; disks of uncertain use, 67, 68, 69, 73, 75, 77, 79; ear studs, 13, 73; foundation cone, 4; hearth, 83;

- inlay, 73; jar sealings, 5, 32-33, 65, 67, 71, 75; layer in Pit F, 8; loom-weight, 56, 59; mace-head, 62; models (axe) 76, (boat) 41, 58, (brick) 34, (chariots) 28, 37, 75, (tools) 8, 9, 71, 78, (wheels) 28, 60, 71, 75, 76, 78; net sinkers, 8, 11, 20, 84; offering table, 56, 78; pin, 68; plaster, 7; platform, 9; potter's wheel, 62; rattle, 61, 71, 76; ring, 71; seal-impressions, 17, 28, 32, 33, 40, 49, 55, 60, 61, 62, 63, 64, 65, 67, 71; sickles, 8, 10, 11, 13, 14, 59, 64, 67, 68, 69, 71, 73, 74, 75, 84; sling bolt, 58, 59, 64, 68, 73; smoother for, 67, 73; spindle whorl, 8, 60, 67, 68, 73; spool, 66, 67, 75; spoon, 66; tops, 37, 76; toys, 37; weaver's comb, 13; *v.* Animal, Brick, Cone mosaic, Drain, Figurines, Pottery, Terra-cotta.
- Commerce, evidence of, 11.
- Composite figures, 44.
- Cone, foundation, 47; large clay, 75, 81, 99; mosaics, 8, 11, 12, 28, 29, 63, 64, 65, 66, 67, 68, 71, 72, 73, 75; with faces, 81.
- Copper, Armenian, 30, 165; arsenical, 30, 164-165; "blades," 30, 66; bowls, 30, 43, 79; chemical analysis of, 164; chisel, 65; fish hook, 65, 67, 76; fragments, 73, 81; mirror, 30, 43; needle, 71; occurrences of, 9; oxen-hooves, 38; pins, 30, 56, 63, 66, 76; razor, 43; spear-head, 21, 65, 88; spoon, 30; tool, 57.
- Cornets* of Susa I, 73, 74.
- Creation legend, 2, 9.
- Crystal, 84; beads, 43, 66, 67.
- Cylinder, clay, of Dungi, 41.
- Cylinder-seals from Royal Cemetery, 18, 39; First Dynasty, 40; Sargonid, 49-50; Pit F, 57, 58, 65, 67.
- "Cyrus" gate of Late Temenos, 40.
- Dada, 47.
- Dada-ilum, inscription of, 47.
- Dagger, 78; bronze, 39.
- Dates (fruit), 41.
- Dedication-bowls, 41.
- Delougaz, P., 35.
- Demon, on bowl, 51.
- Desch, C. H., 164.
- Die, 79; bone, 44, 88; pottery, 44.
- Diqqiqqeh, foundation-cone from, 47.
- Diorite, 26; bowl, 61, 64, 71, 75; head, 52; jar-cover (?), 71, 76; statues, 47, 48, 51-52.
- Disk of Sargon's Daughter, 49.
- Disks, pierced, 14, 67, 68, 69, 73, 75, 77, 79, 87, 96; from potsherds, 58; stone with wire attachments, 72, 83.
- Dog, on seal, 43; (?) bones, 82.
- Dragon on seals, 50.
- Drains, "aspu," 41-42; of First Dynasty, 3, 56, 57; of Third Dynasty, 56, 57; Pit F, 56-69 *passim*; Pit G, 69; Pit X, 77; EH Site, 81.
- Drill, 26; for stone, 14, 75, 84.
- Dumuzi, 18.
- Dungi, daughter of, 51; inscriptions of, 57; temple of, 40, 41, 45, 80; Sargonid graves in Mausoleum of, 145.
- Ea, 7, 50, 51.
- Eagle, on seal, 50, 62.
- E-a-na-ka, in Lagashite inscription, 47.
- Eannatum, Stela of the Vultures, 45, 47.
- Eanna Ziggurat at Warka, 38.
- Ear rings, gold, 39; silver, 30.
- Ear studs, 13, 73.
- EH site, 10, 38, 40, 41, 56 ff., 80-82.
- Elam, influence on Jamdat Nasr art, 33; loot from, at Ur, 51.
- Enannatum, governor, 47.
- En-anni-padda, 51.
- En-he-du-an-na, 49.
- Enlil, dedication to, 51.
- Entemena, statue of, 47-48.
- E-Nun-Mah, drains in palace of, 41; inscription from temple of, 45; jewelry hoard, 43; limestone relief bowl from temple of, 52; mace-head from temple of, 49; pavement of plano-convex bricks, 40; temple treasury of, 32, 43.
- Erech, Dynasties of, 17, 18, 48; Gilgamesh, early king of, 18; Utu-legal of, 53; Lugal-zaggisi of, 48; *v.* also Uruk, Warka.
- Eridu, pottery, 21.
- Esir-é-a, 162.
- Esir-lah, 162.
- Euphrates, 11, 15, 19, 68; asphalt from banks of, 161.
- Ex voto, boat relief, 42; cups in "apsu" drains, 41-42; inscribed bowls, 50; mace-heads, 51.
- Factory, pottery, in Pit F, 4, 26, 64-66; *v.* Kilns.
- Fara, texts, 5.
- Figurines, al 'Ubaid period, 8, 20, 71, 77, 90, 91, 92, 95, 97, 99; animal, 12, 37, 67, 69, 71, 75, 76, 78, 80; clay, 8, 20, 59, 64, 65, 68, 71, 75, 78, 80, 90, 91, 92, 95, 97, 99; female, 12, 59, 64, 90, 91, 92, 95, 97, 99; from Reijibeh, 10; male, 12; religious significance of, 12; types of, 2; uncertain, 71; woman with infant, 95.
- First Dynasty, of al 'Ubaid, 36.
- First Dynasty of Erech, 18.
- First Dynasty of Ur, 2, 16, 18; buildings, 40-41, 80; caches of objects, 42, 43; in King Lists, 18; levels on EH site, 80-82; pottery types of, 43; sculpture, 43; seal-impression stratum, 5, 40; small objects, 43-44.
- Fish, as food, 82; bones of, in foundation deposit, 41; hooks, 65, 67, 76; on relief, 42.
- Flint, 84; arrow heads, 14; blades, 14; chips, 71; core, 68, 79; flakes, 79; hoe, 62, 66, 67, 69, 71; saw, 71; set in bitumen, 67.
- Flood, 2, 10, 15-19, 22, 68-69, 76, 82; asphalt from Flood stratum, 160-162; layer (EH site) 82, (Pit F) 68-69, (Pit W) 76; legend, 7; silting, 4, 6; *v.* also Silt.
- "Flower" pots (Jamdat-Nasr), 22.
- Food, animal bones, 56, 82; barley, 31; fish bones, 59; in foundation deposits, 41; grain, 56; vegetable matter, 82.
- Forbes, R. J., 160-163.
- Fossils, in Royal Cemetery, 2.
- Foundation-cone, 47.
- Foundation deposit, bones, 56, 57; grain, 56; pot, 81; "tables of God," 41; tablet of A-anni-padda, 40; vegetable matter, 56.
- Frankfort, Henri, 28, 36, 38, 50; at Tell Asmar, 43.
- Frit, vase, 30, 63, 66; bead, 67.
- Frog amulets, 39.
- Furniture, throne, 42.
- Gadd, C. J., 45, 49, 50.
- Garrod, Dorothy, 14.
- Genouillac, H. de, 163.
- Geological Survey, Department of, 15, 165.
- Gig-par-ku temple of Nin-Gal, 40; dedications from, 45, 49, 51; drains in, 41, 42.
- Gilgamesh, cycle, 16; early king of Erech, 18.
- Glaze, beads, 30, 43, 66, 67, 88; on vase, 30, 63, 66.
- Goat, bones in foundation deposit, 41; as food, 82; harp from Royal Cemetery, 31; sacrifice on plaque, 45.
- Gold, 8; bead of A-anni-padda, 40; beads, rings, ear rings in Royal Cemetery, 39; frog, 39; handle, 44; sheet, 44; strip of, 75.
- Government, 11; change of at end of Jamdat Nasr, *v.* different dynasties.
- Graffito sherd, 72.
- Grain, barley, 31; calcined, 56.
- Granite, bowl of Naram Sin, 51; stela of Ur-Nina, 46.
- Graves, *v.* Cemetery.
- Great Death-pit, 2.
- Grind-stones, 10, 58, 61, 69, 84.
- Gschnitz glacial phase, 19.
- Gudea, active at Ur, 51-52; at Lagash, 51; statues of the type, 51-52; stone vase of, 32.
- Gur, 162.
- Guti, rule at Ur, 51.
- Gypsum, at Mereijib, 83; trough, 31.
- Hackford, J. E., 158.
- Haematite paint, lumps, 79, 97; on bones, 20, 97, 98; on figurines, 20; on pots, 21, 22, 60, 88.
- Hall, H. R., 47.
- Haller, A. von, 22, 23.
- Hammering, of copper bowls, 30; of lead vessels, 31.
- Harden, D. B., 36, 38.
- Hearths, 58, 69, 83.
- Heinrich, E., 31.
- "Herring-bone" coursing, 34, 35, 58, 70, 82.
- Hit, 11, 16; asphalt from, 159, 161.
- Hoe, 10, 11, 62, 66, 67, 69, 71, 84; types, 14, 84.
- Houses (at Ur), al 'Ubaid, 7; drains in, 41; Early Dynastic, 37; Jamdat Nasr in Pit F, 30, 31; Larsa period, 41; life of mud walls of, 30; Persian, 31, 40, 50; in Pit F, 56-69 *passim*; in Pit G, 70; Uruk period, 27; (at Tell Asmar), 50.
- Ibex, on stone plaque, 47.
- Ibi-Sin, bricks of, 58.
- India, 8, 11, 50.
- Indus valley civilisation, connections with, 50.
- Inlay, Jamdat Nasr technique of, 32; shell, 32, 38, 79; at

- Tell Asmar, 38.  
 Inscriptions, A-anni-padda, 40; alabaster vase, 84; Al-(zu?), 47; calcite cup, 45; clay copies of, 51; Entemena, 47; graffito sherd, 72; Lagashite period, 45-46, 47; libation plaque, 45; Manishtusu, 51; Meski-agnunna, 40; Ne...dar, 84; Sargonid period, 51; Ur-Nina stela, 46; *v.* also Tablets, Writing.  
 "Introduction scene," on seals, 50.  
 Iran, Elamite influence from, on Jamdat Nasr art, 33.  
 Iron, oxide of, 56.
- Jamdat Nasr period, (at Kish) 34; (at Ur) 23, 29-34; cemetery, 24, 30, 33, 71, 76, 79, 80, 103-126; copper, analysis of, 164; fire at end of period, 34; houses, 30, 31; inlay, 32; kilns, 28-29; metal types, 30, 31; pottery, 3-5, 23, 26-29, 30, 33; pottery types from elsewhere than graves, 153-154; pottery types from graves, (early) 148-149, (common) 150, (late) 151-153; sculpture, 31; stone vessel types, 31, 155-157; tabular analysis of graves, 103-126, (in Pit W) 104-110, (in Pit X) 110-124, (in Pit Y) 125-126, (in Pit Z) 126; writing 32-33; (at Warka) 17, 29.  
 Jamdat Nasr (site) pictographic tablets from, 5, 29; buildings at, 29; destruction of, 33.  
 Jar-sealings, 32-33, 62, 65, 71, 79; *v.* also Seals, Seal-impressions.  
 Jastrow, M., 13.  
 Jewellery, "dog collar" from Kish, 43; E-nun-mah temple hoard, 42; Tell Asmar hoard, 43; *v.* also Beads, Ear rings, Gold, Silver, etc.  
 Jordan, J., 9, 12, 13, 17, 32, 34, 35.
- Karun, 11.  
 Kassite period, houses, 77; shrine, 34.  
 Kaunakes, on limestone relief, 46; shell inlay, 44; worn by *patesi*, 47.  
 Khafaje, 9, 35.  
 Kiln, in Pit F, 28, 64, 65, 66; gratings for, 65; smother-kiln, 22, 23, 27, 37; wasters, 4, 65.  
 King-lists, 2, 11, 16, 17, 18, 45, 51.  
 Kish, 1, 6; end of Jamdat Nasr period at, 34; flood at, 15, 16; plano-convex period at, 35, 38; reserved slip ware at, 36; revival of Uruk ware at, 37; temple at, 38; terra cotta head from, 37; unknown king of, 47; Watelin at, 43.  
 Kisu buttressing, 59.  
 Kur-lil, 47.  
 Kurnah, 17.
- Lagash, Gudea period at, 51; Ur-Nina period at, 46.  
 Lagashite period (at Ur), 2, 17, 44-48, 51-53; inscriptions, 45-48; libation plaque, 45.  
 Langdon, S., 15, 16, 37, 38, 43.  
 Lapis lazuli, beads, 32, 43, 56, 57, 61; inlay, 32, 39, 43.  
 Larsa (period at Ur), bricks, 58, 72; drains, 41; terra cottas, 46.  
 Lava, quern, 58, 61.  
 Lawson, S., 158.  
 Lead, bowls, 30, 31; chemical analysis of, 165; dishes, 30, 31; techniques, 31; tumblers, 30, 31.  
 Legrain, Abbe Leon, 17, 32, 33, 46, 47, 49.  
 Libation-plaque, 45.  
 Lime, as floor coating, 75.  
 Limestone, 26; architectural use of, 31; beads, 32; bowl, 52, 61, 75, 80, 87; bull, 61; cup, 31; figures for inlay, 43; head, 37; inlay, 43; libation-plaque, 45; mace-head, 75; quern, 42, 84; rams, 42; relief, 46; vase, 52, 60.  
 Lion, 32, 43.  
 Loftus, W. K., at Warka, 29.  
 Loom-weight, 56, 59.  
 Lugalbanda, 18.  
 Lugal-ki-gub-ni-du-du, 45.  
 Lugal-kisalsi, 45.  
 Lugal-zaggisi, 48.
- Mace-head, clay, 62; limestone, 75; of Sargon, 49; stone, 21, 32, 49, 51, 75, 87.  
 Mackay, E., 23, 29, 32, 34.  
 Mallowan, M. E. L., 11, 43.  
 Manishtusu, 51.  
 Marble, bead, 66; bowl, 65, 69; head, 52; pendant, 65.  
 Marduk, 9.  
 Mari, dynasty of, 45, 47.  
 Mastic, constructional, *v.* Bitumen.  
 Matting, uses of, in burials, 21, 87; in collection of bitumen, 162; in foundation deposits, 41, 56; in wall trench, 56; on floor, 81, 82.  
 Measures, 51, 162.  
 Me-enlil, 51.  
 Mereijib, 8 fn., 10, 24, 82-85; chemical analysis of cement brick from, 158; house walls at, 29.  
 Mes-anni-padda, in king-lists, 18; on seal-impressions, 5, 40.  
 Mes-kalam-dug, grave of, 14, 39; arrow-heads in, 14; frog amulet in, 39; shell cylinder seal in, 39.  
 Metal, vessels, 38, 39; from Tell Asmar, 38; in plano-convex period at Ur, 39; *v.* also Copper, Gold, Lead, etc.  
 Military cemetery, 39.  
 Miniature vase, 43, 64, 65, 71, 99.  
 Mirror, copper, 30.  
 Models, axe, 9, 76; blade, 71; boats, 41; bricks, 34; chariot, 28, 37, 75; sickles, 8, 10, 11, 13, 14, 59, 64, 67, 68, 69, 71, 73, 74, 75; wheels, 28, 60, 71, 75, 76.  
 Moon-god, 50, 52.  
 Moon-goddess, 45, 49, 50.  
 Mortar (mud), 56, 69; *v.* Grindstone.  
 Mosaic "standard," 39, 46.  
 Mother-of-pearl, frog, 39; inlay, 32.  
 Muqeyer, 80.  
 Mythology, on seals, 50; *v.* also Religion.
- Nabonidus, 47, 48; enclosure of, 47.  
 Nannar, 51; on moon-disk, 49; on seals, 50; shrine of, 72; on steatite bowl, 52.  
 Nannar and Ningal, temple of, 52; inscriptions to, 53; *v.* also E-nun-mah.  
 Naram-Sin, 47, 51.  
 Nebuchadnezzar, 80.  
 Necklace, 32; *v.* also Beads.  
 Ne...(dar?), 85.  
 Needle, copper, 71.  
 Neo-Babylonian, reconstruction, 72; Temenos, 80.  
 Net-sinkers, 11, 20, 84; types, 8.  
 Nidaba, on Ur-Nina stela, 46.  
 Nilgiri hills, as source of Amazonite, 8.  
 Nimin-tabba temple, 40, 41, 45, 80.  
 Nineveh, 11.  
 Nin-dar, temple to, 51.  
 Nin-Gal, temple of, 40, 45, 49, 51; bowl from, 51; disk from, 49; plaque from, 45; on seals, 50.  
 Ningirsu, temple to, at Ur, 52.  
 Ningizzida, 13 fn.; on seals, 50.  
 Nin-me-ta-bar-ri, 45.  
 Nin-Tur-Nin, 40.  
 Ninurta, on seals, 50.  
 Nippur, inscription, 45.  
 Noah, 15.
- Obsidian, 8; blades, 14; chip, 56, 59, 64, 71; disk, 58; flakes, 58, 69; inlay, 84; "nails," 13; pins, 76; vase, 71.  
 Offering table, 56, 78; *v.* Tables of God.  
 Oman, copper from, 30.  
 Omen-text, 13.  
 Oxen, hooves from stand, 38; relief on stone bowl, 31; rib as implement, 82; *v.* also Bull, Cattle.
- Padgham, E. C., 165.  
 Paint, on clay head, 37; on frieze-inlay figures, 44; on stone libation-plaque, 46; on stamp-seals, 43; on stone rams, 42; on stone statue, 39; remnant in pot, 67; *v.* also Haematite, Pottery.  
 Palette, 56; marble, 43; steatite, 13.  
 Papsugal figures, 34.  
 Paste, beads, 43.  
 Patesi, 47, 48, 51.  
 Peake, 16, 19.
- Peake, H., 16, 19.  
 Pendant, marble, 65; shell, 66.  
 Persian, burials, 77; house, 31.  
 Pestle, *v.* Rubbing stone.  
 Petrography, in analysis of silt, 165.  
 Pictographs, on jar-sealings, 32-33.  
 Pins, bone, 20, 66, 99; bronze, 81; clay, 68; copper, 40; 56, 63, 66, 76; obsidian, 76.  
 Pit A, 2, 54.  
 Pit B, 2, 54.  
 Pit C, 15, 54.  
 Pit D, 55.  
 Pit E, 55.

- Pit F, 3-5, 6, 7, 8, 9, 10, 15, 16, 24, 26, 56-69; al 'Ubaid period, 19-22, 87-101; architecture in, 56; Flood layer in, 68-69; Jamdat Nasr period, 26-29; kilns, 28-29, 64-66; Plano-convex brick period, 35-38, 56-66; pottery factory layer, 26-29, 64-66; strata confirmed by EH, 82.
- Pit G, 3, 6, 69-71.
- Pit H, 71-72.
- Pit K, 15, 72-73.
- Pit L, 8, 15, 74-75.
- Pit W, 6, 13, 24, 32, 36, 38, 75-77; analysis of copper from, 164-165; Jamdat Nasr graves in, 104-110.
- Pit X, 6, 9, 24, 32, 35, 36, 41, 77-79; al 'Ubaid graves in, 101; analysis of graves of Royal Cemetery period in, 127-133; Jamdat Nasr graves in, 79, 110-124; Royal Cemetery period in, 38-39, 78-79, 127-133; Sargonid period in, 134-145.
- Pit Y, 5, 6, 9, 15, 24; Jamdat Nasr graves in, 125-126.
- Pit Z, 4, 5, 6, 10, 15, 79-80; al 'Ubaid grave in, 102; Jamdat Nasr grave in, 126.
- Plano-convex bricks, 2, 4, 29, 34-48, 75; (at Kish), 35, 38; (at Tell Asmar), 36, 40; (at Ur), 34-38, 56-61 *passim*, 80, (end) 48; boxes, 56, 58; EH site, 80-82; hearth, 69; origins of, 35-36; paving, 81; Pit F, 56-61 *passim*; Pit G, 69; reuse of, 34, 69; Ziggurat Terrace filling, 72.
- Plant motives, on pots, 21, 65, 74.
- Plaster, chemical analysis of, 158; mud, 7, 80, 81.
- Plenderleith, H. J., 158, 164.
- Pottery, al 'Ubaid, 5, 7-8, 21, 22, 64-69 *passim*, 71, 72, 73, 74, 76, 79, 80, 83-84, 87-102, 146-147; analysis of Uruk-Jamdat Nasr types, 24-26; arrangement in al 'Ubaid graves, 20; base-rings separately made, 67; burnished, 4, 5, 6, 21, 22, 23, 26, 27, 37, 64, 66, 67, 68, 71, 76; burnisher, 71; cable ornament, 4, 36, 60; combed ornament, 24, 57; dishes on "Tables of God," 41; Early Dynastic period, 37; "egg shell," 74; fire clay, 66; First Dynasty period, 43; "gashed" ornament, 4, 36, 60; grafito sherd, 72; grey (and black) burnished (at Ur), 22, 23, 26, 27, 37, 64, 67, 71, 78; (at Tello), 78; (at Warka), 6; haematitic red, 21, 22, 60, 88; handle types, 4, 24, 27; incised sherd, 72; Jamdat Nasr period, 3-5, 6, 23-25, 26-29, 30, 33, 148-154; jar-sealings, 5, 32-33, 65, 67; kiln stratum in Pit F, 4, 65 ff.; miniature, 43, 64, 71, 78, 99; Minyan, 22; mortaria, 73; painted, throughout *passim*; phallic flask, 67; Plano-convex period, 37; polychrome, 6, 23, 26, 27, 33 and throughout *passim*; potter's wheel invented, 28, specimens of, 62; puddling basin, 66; red burnished (at Ur), 4, 5, 6, 21, 27, 37, 62, 64, 66, 67, (at Warka), 6; reserved slip (at Kish), 36, (at Tell Asmar), 36, (at Ur), 4, 23, 26, 27, 36, 61, 71, 84, 85; rope moulding on, 4, 36, 84; Royal Cemetery period, 43, 48, 49; slips, 23, 73; slow wheel, 8, 28, 73; smoother, 67, 73; smother kilns, 22, 23, 27, 37, 76; three-colour, 6, 26, 27, 33, 73; toilet pot, 43; toys, 37; Uruk-Jamdat Nasr, 4, 22, 23-26, 27, 64-68 *passim*, 71, 85, 148-154; votives, 37; wasters from kilns, 4, 65; zoöomorphic, 28; *v.* also Wheel.
- Pounders, 10, 62.
- Preusser, C., 8.
- Qasat Ma'Moorā, bitumen from, 158.
- Quartzite, arrow head, 68; beads, 43; mace-head, 49.
- Quern, *v.* Grindstone.
- Rams, limestone, 42.
- Rattles, 61, 71.
- Razor, bronze, 43.
- "Red" graves, 20; *v.* Haematite paint.
- Reed and daub construction, in al 'Ubaid I, 7; houses, 7, 54, 69; platforms, 9.
- Reijibeh X, 10, 13, 14.
- Reliefs, alabaster, 42; moon-disk of En-he-du-an-na, 49; on stone vessels, 31, 32, 51, 52; terra-cotta, 29, 84; *v.* Sculpture.
- Religion, al 'Ubaid period, 12-13, 20; "apsu" drains, 41-42; burial positions, 33; chthonic deities, 13 fn.; foundation deposits, 34, 41; Jamdat Nasr period, 33; libation plaque, 45; moon-disk of En-he-du-an-na, 49; orientation of temples, 36; "Tables of God," 41; tomb chapels, 83; underworld, 13 fn.; *v.* Mythology, Ritual, Symbolism.
- "Riemchen" bricks, 28.
- Rimush, 50.
- Ritual, in "apsu" drains, 41, 42; plaque, 45; on seals, 50; on "Tables of God," 41; vessels, 41, 42.
- Roundels, *v.* Disks.
- Royal Cemetery, 2, 16, 41; chemical analysis of plaster from, 158; dating, 3, 5; early walls in, 69-70; further graves of period, 38, 39, 127-133; harps from, 31; jewellery types, 43; plaster from, 158; redating of Second Dynasty graves, 48; Sargonid graves in area, 145; seal-impression strata, 5; Second Dynasty graves, 48; Trial Pits in area, 54-72, 75-77, 79-80.
- Rubbing stone, 55, 56, 62, 69, 80, 84.
- Sar, 18.
- Sargon of Akkad, 16, 49.
- Sargonid period (at Tell Asmar), 38; (at Ur), 49-53; cemetery over Royal Cemetery, 49; cylinder seals, 49; end of dynasty, 51; graves, 5, (in Pit X), 78, 134-145, (near Dungi's Mausoleum), 145.
- Sarzec, E. de, 32.
- Saw, stone, 71.
- Sculpture, (at Tell Asmar), 36, 38; (at Warka), 31; (at Ur), boar, 31; composite, 44; Early Dynastic period, 37; Gudea period, 51-52; in warrior's grave, 39; Lagashite period, 47; of Royal Cemetery period, 39-40; statue of woman, 39-40; throne-base, 39; *v.* also Reliefs, kinds of stone, etc.
- Seals, chariot on, 28; dog on, 43; Indus Valley style, 50; "introduction scene" on, 50; impression bearing strata, 5, 32, 37, 40, 75, 76, 79; impressions, 17, 28, 32, 33, 40, 49, 55, 60, 61, 62, 63, 64, 65, 67, 71, 75, 79; Jamdat Nasr period, 17, 32; jar-sealing, 32-33, 65, 67, 71, 75; lion's-head stamp, 43; religious myths on, 50; Sargonid period, 49-50; stamp, 65, 81; technique, 13, 50; stone, 65; *v.* also Cylinder seals.
- Second Dynasty of Ur, 45.
- Sequence of periods, 1 ff.
- Shale disks with wire attachments, 72.
- Shamash, on seals, 50.
- Sheep, 41, 82.
- Shells, 80; beads, 8, 20, 43, 61, 66, 76, 87, 89; bracelet (?), 61; bull amulet, 80, 92; cylinder seal, 39; 57, 58; engraved strips, 44; inlay 32, 38, 79; *kaunakes*, 44; "nail," 13; pendant, 66; plaque, 45, 46, 61; stone copy of a, 31.
- Shrine, on seals, 50; doors with spear and ring, 45, 78.
- Sickles, 73; bone, 14; clay, 8, 10, 11, 13, 14, 59, 64, 67, 68, 69, 71, 73, 74, 75, 83; wood, 14; stone blades for, 14 fn.
- Silt, 11, 15, 17, 18, 21, 22, 68-69; chemical analysis of, 165; *v.* also Flood Deposit.
- Silu, 47.
- Silver, beads, 81; bracelets, 81; finger ring, 43; pendants, 43.
- SIS, (Seal Impression Strata), 5, 32, 37, 40, 75, 76, 79.
- Skeletons, in al 'Ubaid graves, 87-102; position of in Jamdat Nasr, 33; *v.* Cemetery.
- Sling-bolts, 58, 59, 64, 68, 73.
- Slip, 4, 23, 73; method on reserved-slip ware, 4.
- Slow wheel (potter's), 8, 28.
- Smith, S., 9, 42.
- Smother-kiln, 22, 23, 27, 37, 76.
- Snake, attribute of Ningizzida, 13 fn.; on seals, 50.
- Soil reclamation, 11.
- Soldering, on lead vessels, 31.
- Sorbonne, 15.
- Spear-head, copper, 21, 65, 67, 78, 88.
- Spielmann, P. E., 158.
- Spindle whorl, 13; clay, 66, 67, 68, 69, 73, 75; stone, 56, 71.
- Spinning top, 37.
- Spool, clay, 66, 67.
- Spoon, clay, 66; copper, 30.
- Stamp-seal, 65, 81; dog, 43; lion's-head, 43.
- Standard, mosaic, 39.
- Statue-base, inscribed, 51.
- Steatite, beads, 8, 20, 64, 65, 66-67, 92; boar, 31, 67; bowls, 14, 26, 31, 51, 52; in composite frieze, 44; cylinder seals, 65, 67; mace-head, 32, 87; oxen-bowl, 52; technique of making bowls of, 14 fn.; *v.* also Stone.
- Stela of the vultures, 45, 47.
- Stone, amulet, 67; bead, 58, 67; disks, 72, 83; ear studs, 13; statue, 39-40; stela, 45, 46, 47; throne-base, 42; *v.* also Inscriptions, Reliefs, Sculpture, kinds of stone, e.g. Alabaster, Steatite, etc.
- Stone implements, adze, 77; al 'Ubaid, 8; arrow-heads, 14; axe, 9, 21, 87; blades, 14; borer, 14; burnisher, 71; celt, 14, 69, 84; drill, 14, 75, 84; from Reijibeh, 10; grindstone, 10, 58, 61; handle, 67; hoes, 14, 62, 66, 67, 84; mace-head, 21, 32; pounder, 79, 84; rubbing stone, 55,



- 56, 62, 69, 80, 84; saw, 71; spindle whorl, 56, 71; whetstone, 56, 57.
- Stone vessels, al 'Ubaid I, 8; III, 21; borers for, 14, 75, 84; cup in Louvre, 32; Early Dynastic types, 37; First Dynasty cache, 43; from Bussokheir, 37; from Mereijib, 37, 82, 83, 84, 85; inlay in, 32; in Pit F, 60, 61, 63, 64, 65, 69; in Pit G, 71; in Pit W, 75, 76; in Pit X, 78; in Pit Z, 80; in Royal Cemetery, 38; method of making, 14 fn.; Sargonid, 51; *v.* also kinds of stone, e.g. Alabaster.
- Storm-bird, on seals, 50.
- Studs, for the ear, 13, 73.
- Subartu, 51.
- Sumerian King-lists, 2, 51.
- Sumerian physical type, 39.
- Sun-god, 50.
- Susa, 24, 33, 51.
- Sweating technique, of lead vessels, 31.
- Symbolism, barley and oxen on bowl, 31; "fertility," 31; of plano-convex brick, 35; *v.* also Cylinder seals, Religion, Ritual.
- "Tables of God," 41.
- Tablets, (at Jamdat Nasr), 32-33; (at Ur), 3; in Pit D, 55; in Pit F, 56, 57, 59; in Pit G, 71; in Pit X, 79; in EH, 82; pictographic, 4, 32; pre-Royal Cemetery, 5, 55; (at Warka), 32.
- Tabular analyses of graves, Jamdat Nasr period, 103-126; Royal Cemetery period in Pit X, 127-133; Sargonid period, 134-145.
- Tal-esh-Sheikh, 20.
- Tal Halawieh, 37.
- Tammuz, temple dedicated to, 51.
- Tattooing, on figurines, 12.
- Taylor, J. E., 9, 40, 41, 80.
- Tell Arpachiyah, 11, 74.
- Tell Asmar, 36, 37, 38, 39, 50, 84.
- Tello, 78.
- Temenos, Neo-Babylonian, 80; Sacred, of Ur, 3, 77; Third Dynasty, 80.
- Temple architecture, (at Kish), 38; (at Ur), 12, 36; Sumerian, 8; *v.* Architecture, names of deities.
- Terra-cotta, bath, 80; beads, 54; head from Kish, 37; miniature box, 71; reliefs at Ur, 84; at Warka, 29; *v.* Clay, Drains, Figurines.
- Third Dynasty of Ur, 10, 51; arrow heads, 14.
- Thomas, U. U., 165.
- Thompson, R. Campbell, 11.
- Tigris, 11, 19.
- Tin, absent in Jamdat Nasr copper, 164-165.
- Tomb mound (EH), 10, 38, 40, 41, 56 ff., 80-82.
- Trade, see Commerce.
- Transbaikalia, source of amazonite, 8.
- Tree, design, 65; of Ningizzida, 50.
- Trefoil design, 52.
- Trial pits, *v.* Pits A-Z.
- Tribulum, 14.
- Trough, gypsum, in British Museum, 31.
- Underworld, 13 fn.
- Ur-bau, 51.
- Ur-mah-dim, on seal, 50.
- Ur-Nammu, (at Ur) inscriptions of, 53; palace, 44; (at Warka), 38.
- Ur-Nina reliefs, 46, 47, 48.
- Ur-Ningirsu, of Lagash, 52.
- Uruk period, (at Kish), 37; (at Ur), 23, 28, 29; cement buildings, 85; invention of potter's wheel, 28; kilns, 28-29; people, origins of, 30; Plano-convex period as revival of Uruk, 35, 37; stratum in Pit F, 28, 29; tradition in stone work, 32; ware, 17, 22, 23, 28, 29; *v.* Erech, Warka.
- Urukagina, 48.
- Uta-napishtim, 7, 15-16.
- Utu-hegal of Erech, 53.
- Van Buren, E. D., 13.
- Vegetable matter, 56, 61, 75, 79, 82.
- Votives, alabaster statue of woman, 39; figurines, 13; models of wheels and chariot, 37.
- Wadi al Batn, 11.
- Wall decoration, pots, 84 fn.; *v.* "Bent nails," Cone-mosaics, Disks.
- Warka (the site), 1, 6, 9, 10, 15, 17, 21, 22, 27, 28, 29, 32; Anu-Ziggurat at, 12, 31; buildings at, 12, 28, 31; end of Jamdat Nasr period at, 34; Loftus at, 29; Plano-convex period at, 35; Stone work at, 32; Uruk period pottery at, 37; Uruk buildings at, 31.
- Watelin, L. Ch., 15, 34, 36, 37; at Kish, 43.
- Water-god, 7, 50, 51.
- Weapons, in graves, 21; *v.* also under kinds of weapons, and materials.
- Weaver's comb, replica, 13.
- Weights, mina, 162; shekel, 162.
- Wheel, 28, 60, 71, 75; earliest wheeled vehicle, 28; of model chariots, 28, 37; potter's invented by Uruk people, 28; precision on potter's, 25; slow, potter's, 8, 28.
- Whetstone, 56, 57.
- Willcocks, Sir William, 17.
- Wood, lumps of, 75; sickles, 14; smoother, 73; wall-timbers, 72.
- Writing, 16, 18; Indus script on seals, 50; Jamdat Nasr period, 32-33; *v.* also Tablets.
- Ziggurat of Eanna (at Warka), 38.
- Ziggurat Terrace, Archaic II, 72; drains on, 41; Jamdat Nasr period, 36; First Dynasty, 35, 40; First Dynasty cache in, 43; walls of, 29.
- Zoöomorphic vase, bird, 28.
- Zu, on seals, 50.



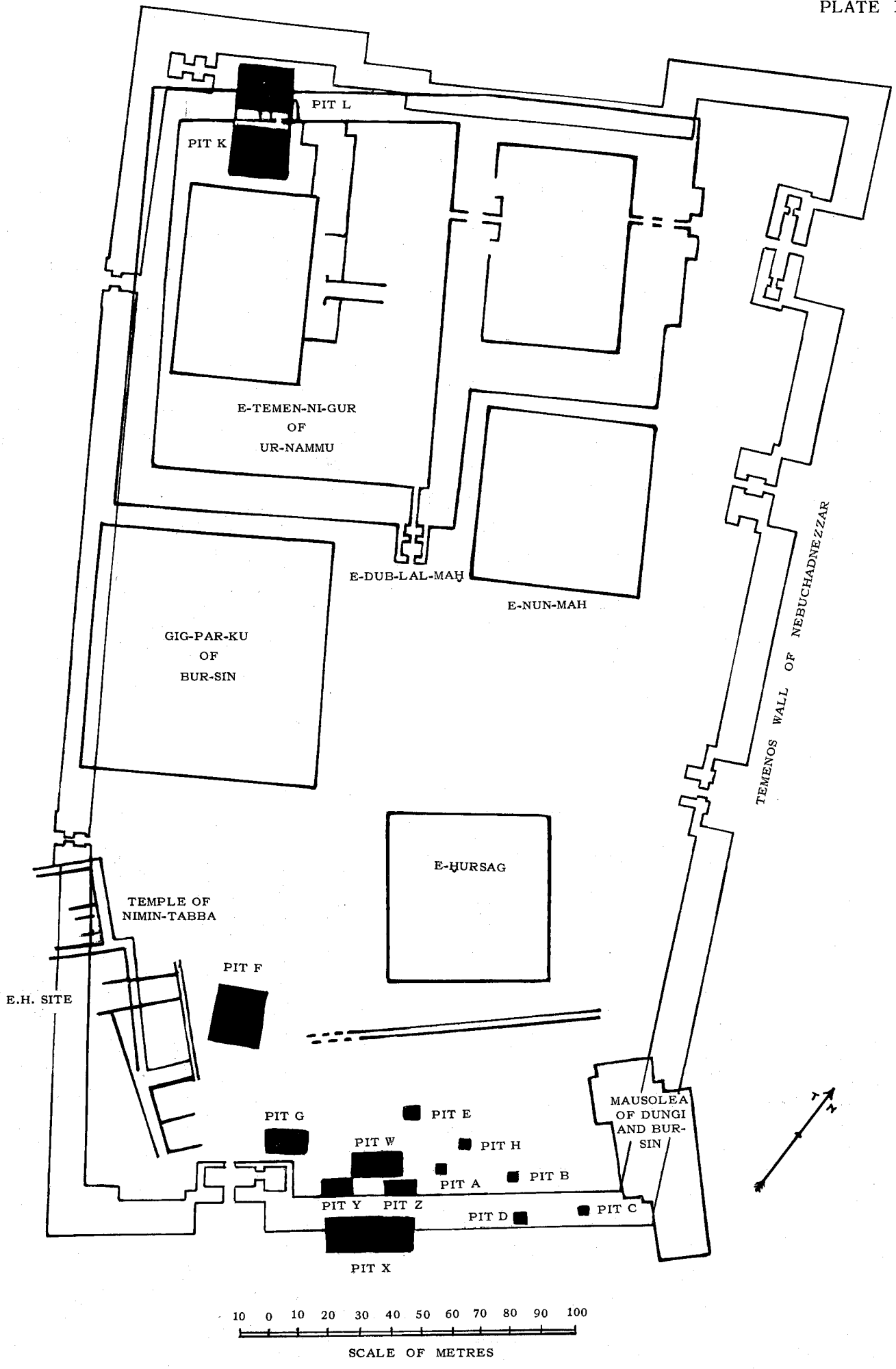

PLAN OF THE TEMENOS ENCLOSURE, SHOWING EARLY SITES



a. Pit F, Square D5, level 17.00-16.00 m. Minute soil stratification due to continued wind and water action in an enclosed space. *V.* pp. 16, 58.



b. Pit F, Square E6. Drainage system against a house wall of the second level. *V.* p. 58, also Pl. 74, Stratum B.



c. Pit F, Squares C-E, 5-6. Buttressed wall at the third level, after the removal of the sloped *hisu* from the further section. *V.* p. 58, also Plate 74, Stratum C.



d. Pit F, Square C8, level 14.00 m. Deposit of clay cups containing animal bones and vegetable matter at the bottom of a "drain" shaft. *V.* pp. 42, 60.

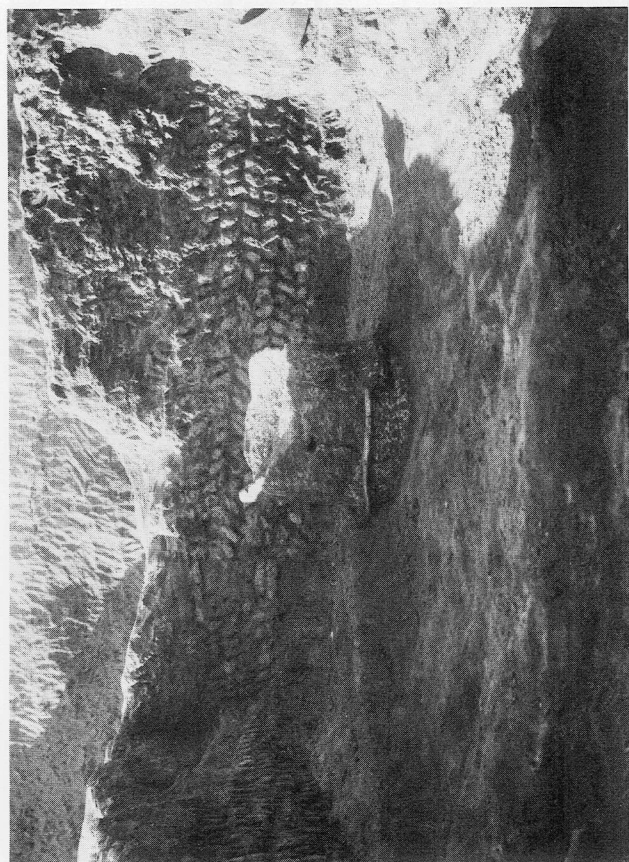

a. Pit F, Square E7. Wall of plano-convex mud bricks laid in herring-bone fashion. *V.* pp. 60-61, also Plate 75, Stratum E.

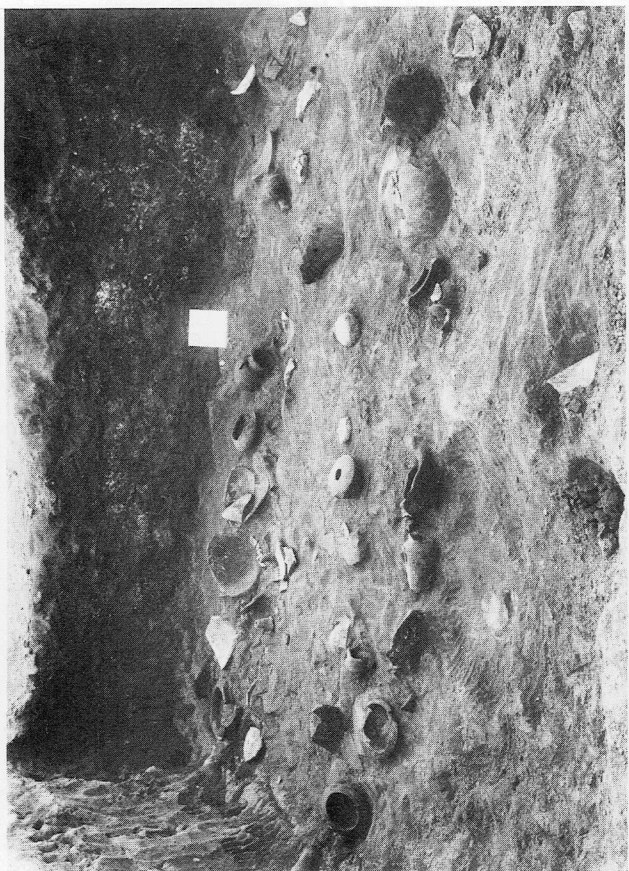

b. Pit F, Square D7. Floor of room with "reserved slip" pottery *in situ*. *V.* p. 60.



c. Pit F. A kiln with a batch of pots still inside. *V.* pp. 65, 66.



d. Pit F. The kiln seen in section. *V.* p. 65.



a. Pit F. "Basin" built of cement bricks for the pottery works, and a stack of vessels in position. *V.* p. 66.



b. Pit F, work at the 8.00 m. level. The line of stones in the back face is a wall-foundation of a Level H building; the "basin" of cement bricks is in the right foreground.



c. Pit F. Grave PFG/D, showing the furniture of an al 'Ubaid III burial. *V.* p. 87.



a. Pit F, Grave PFG/M, showing the flexed position of the legs in the al 'Ubaid burials. *V.* p. 89.



c. Pit F, Grave PFG/Z, showing the fully extended position of the body in the earlier al 'Ubaid burials. *V.* pp. 20, 93.



e. Pit F, Grave PFG/JJ. An early grave, the body fully extended and painted pottery vessels numerous. *V.* pp. 20, 97.



b. Pit F, Grave PFG/L. *V.* p. 88.

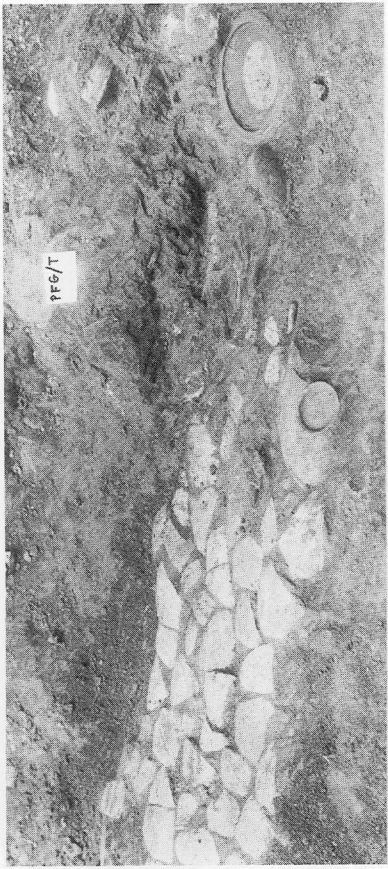

d. Pit F, Grave PFG/T. The bottom of the grave-shaft is paved with a mosaic of broken pottery; offerings on the right. *V.* pp. 20, 91.

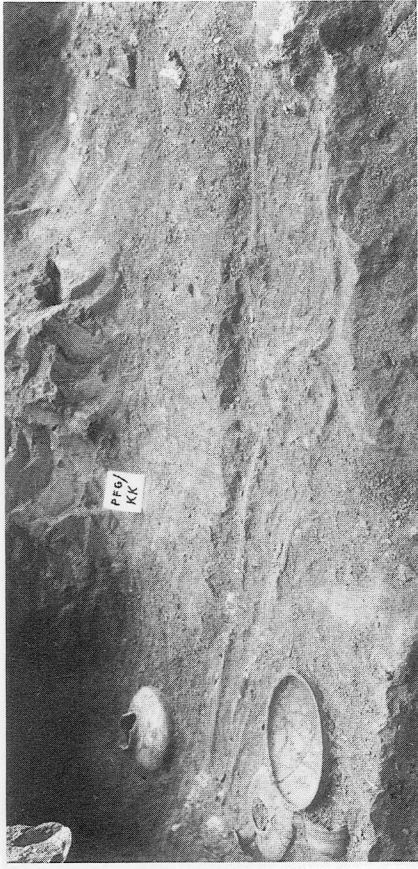

f. Pit F, Grave PFG/KK. The body fully extended, offering vases at the feet, near the head a clay figurine. *V.* pp. 20, 98.



a. Pit F, Grave PFG/P, showing pottery grouped round the skull. *V.* pp. 20, 90.



b. Pit F, Grave PFG/Q, showing the offering vessels and part of the floor-mosaic of pots. *V.* pp. 20, 90.



c. Pit F, Grave PFG/AA. *V.* p. 94.



d. Pit F. Remains of brick construction below the Flood deposit. *V.* p. 7.



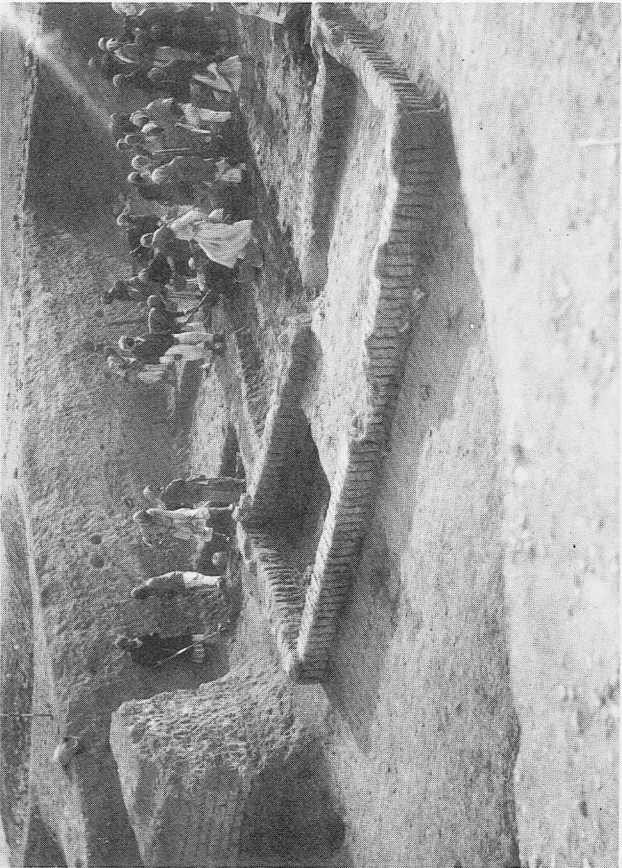

a. Pit X, initial stages. On the left, heavy Neo-Babylonian walls; below them, in centre, walls of an earlier shed. *V.* p. 77.

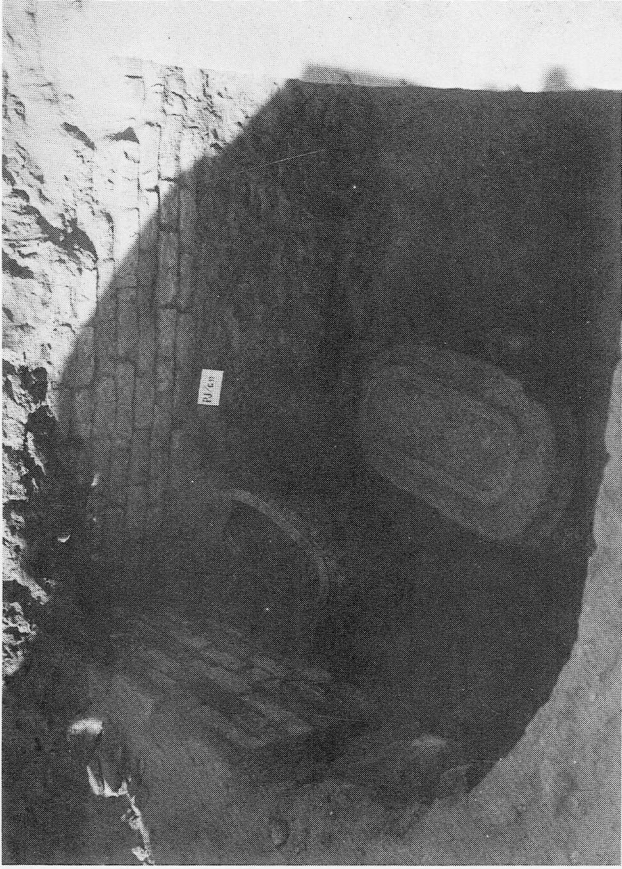

b. Pit X. Clay coffins below the rooms of Kassite houses. *V.* p. 77.

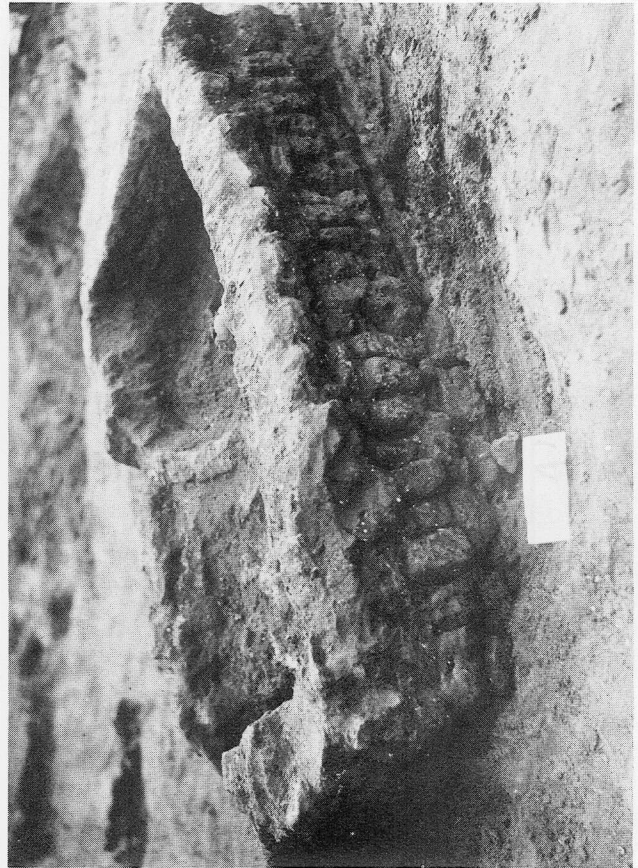

c. Pit X. A Sargonid grave lined with mud bricks. *V.* p. 135.



d. Pit X. A Sargonid grave with bitumen boat and clay vases. *V.* p. 135.

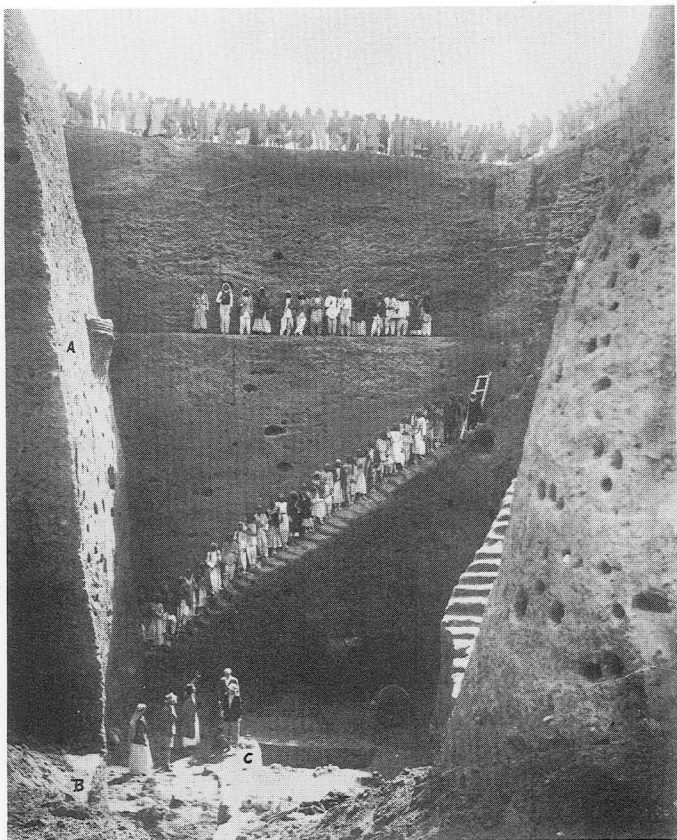

a. Pit X, the pit completed. At (A), a Sargonid clay coffin; at (B), lowest Jamdat Nasr graves; at (C) shaft through pit floor into Flood deposit.



b. Pit X, Grave JNG/325, showing a burial in a coffin of wickerwork. *V.* p. 123.



c. Pit X, Jamdat Nasr burials on the pit floor. The cut through the floor shows x-x, the lower part of the Flood deposit and y-y, black organic soil containing potsherds. *V.* pp. 33, 79.



d. Pit Y, Grave JNG/361, showing the contracted position of the body typical of the Jamdat Nasr period. *V.* p. 125.

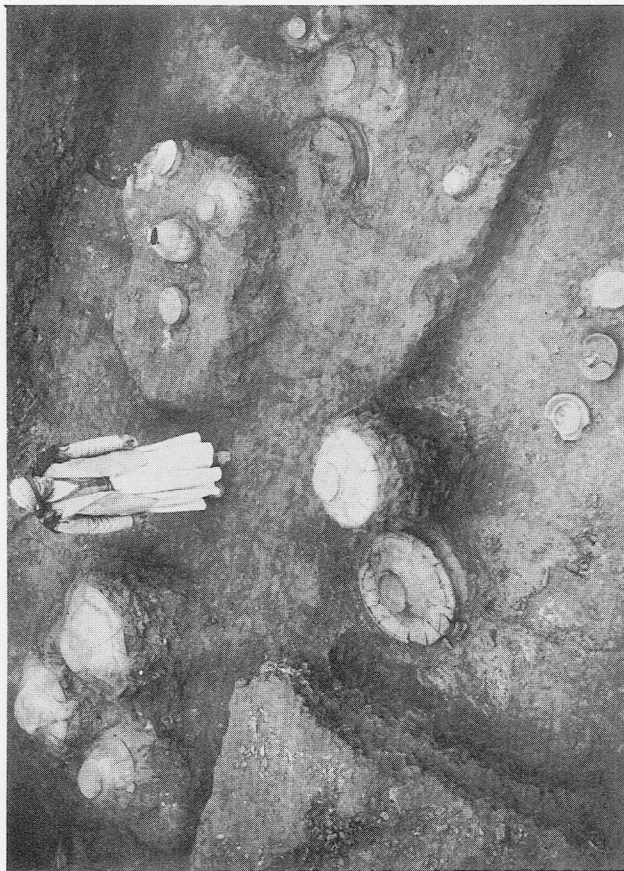

a. Pit W. Clay bowls inverted above the Jamdat Nasr Graves.  
V. p. 79.



b. Pit X. Grave JNG/188 showing a large bowl inverted above the grave. V. pp. 79, 114.



c. Pit X, Grave JNG/204. V. p. 115.

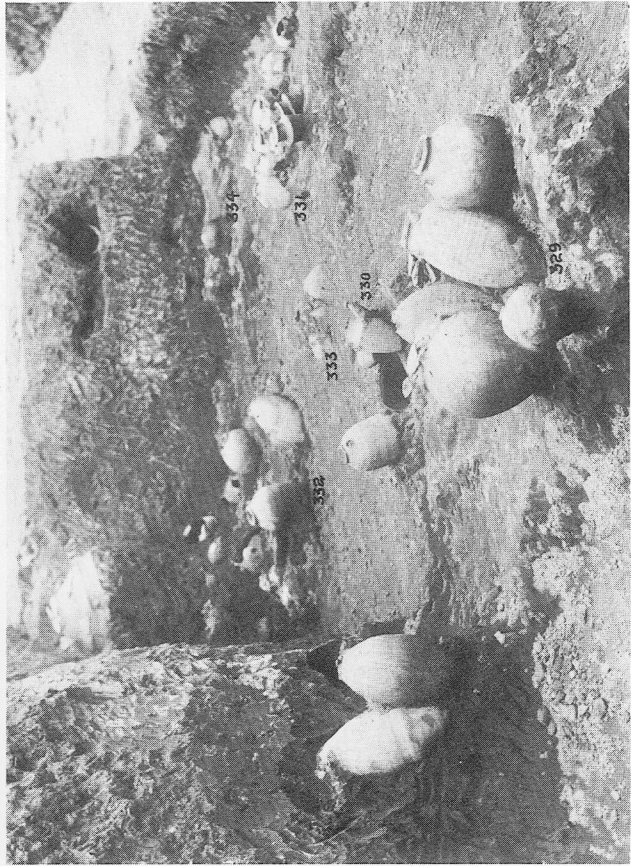

d. Pit X. The lowest stratum of Jamdat Nasr graves. V. pp. 123, 124.

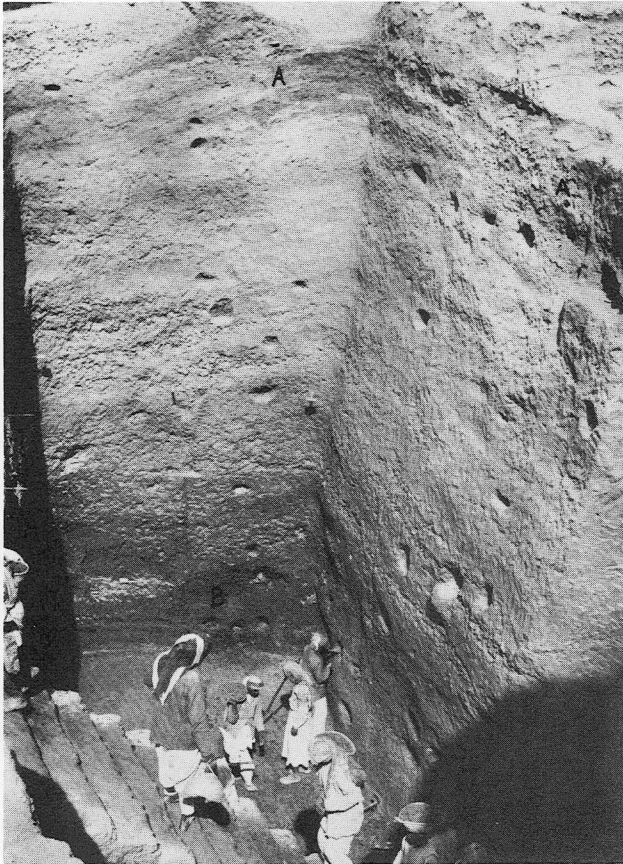

a. Pit W. The NW end of the pit, showing (A) the strata SIS 5-6 and (B) the Flood deposit.

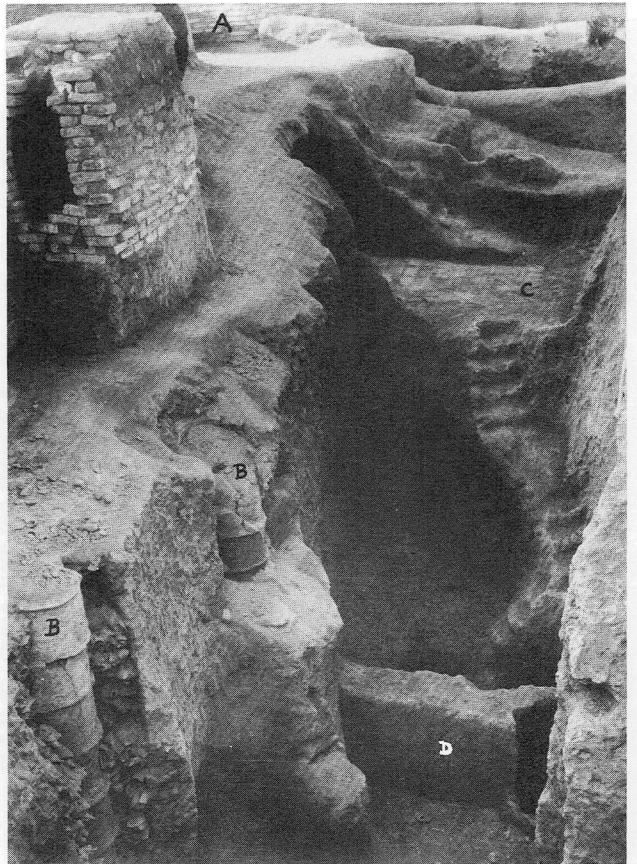

b. Site EH. General view, showing A,A, tombs of the Larsa period; B,B, early drains cut away by the foundations of buildings of the Third Dynasty; C, an Early Dynastic room with paved floor (v. Pl. 11, a), and D, a pre-First Dynasty wall.



c. Ziggurat terrace. A wall of the Archaic II building built with mud bricks of different sizes and shapes, both flat and plano-convex.

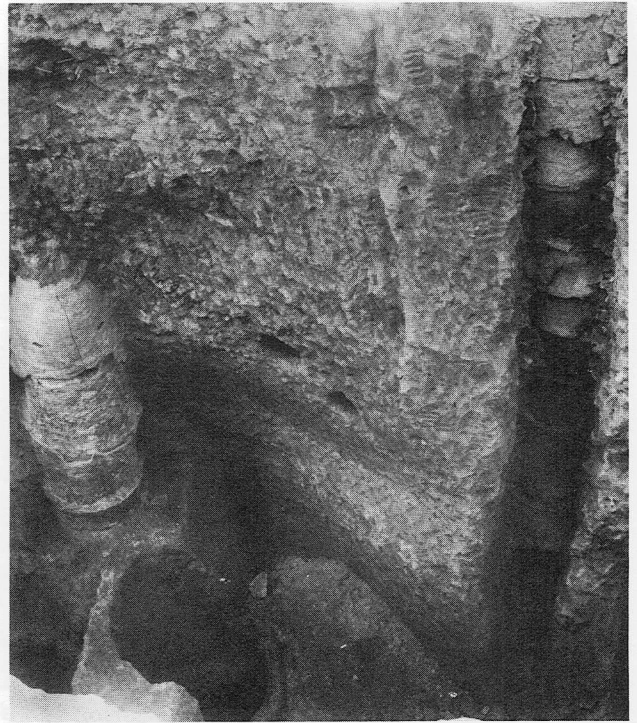

d. Site EH. On the right, a Third Dynasty drain running down into the pre-dynastic levels; in the background, a First Dynasty drain.



a. Site EH. A brick-paved chamber of the Early Dynastic period with two drain-openings. *V.* pp. 41, 81.

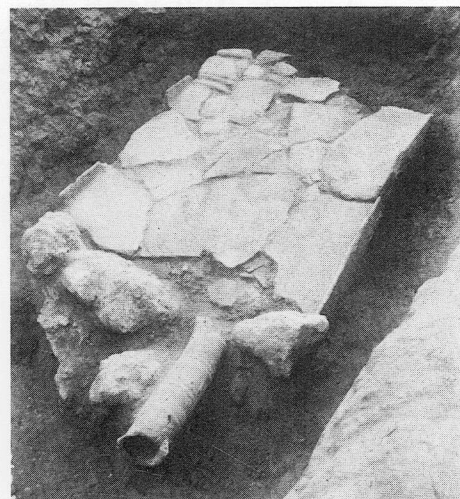

b. Site EH. A terra-cotta bath with out-flow pipe passing through the wall foundations. First Dynasty period. *V.* pp. 41, 80.

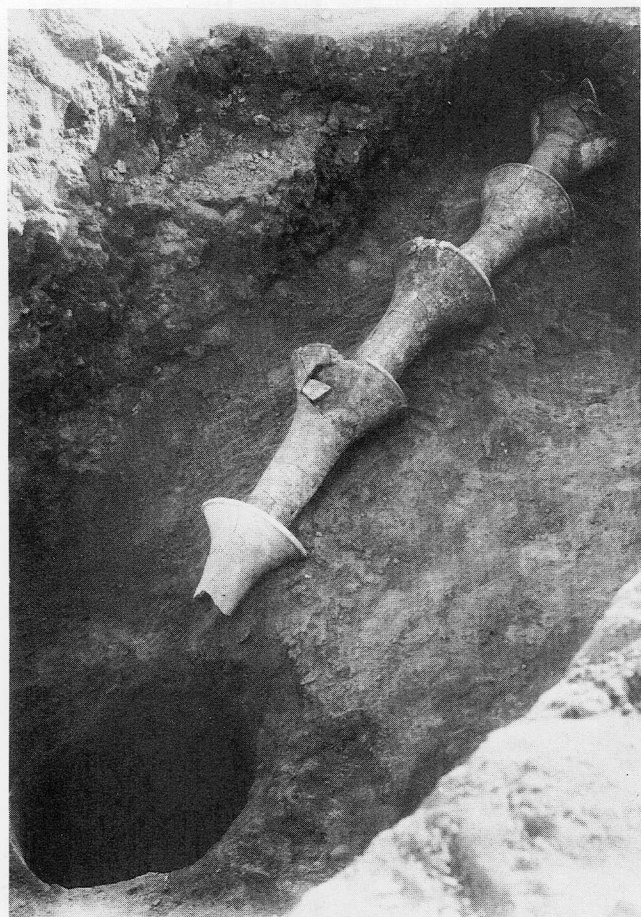

c. Site EH. An Early Dynastic drain of trumpet-mouthed terra-cotta pipes leading to a seepage pit. *V.* p. 41.

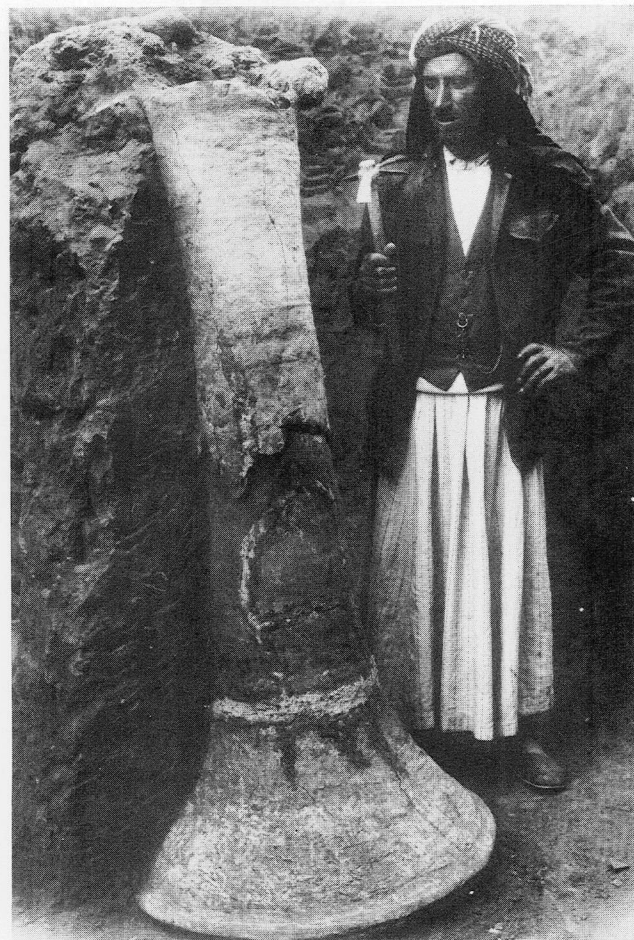

d. Site EH. An unusually large Early Dynastic drain pipe, as found. *V.* pp. 41, 81.

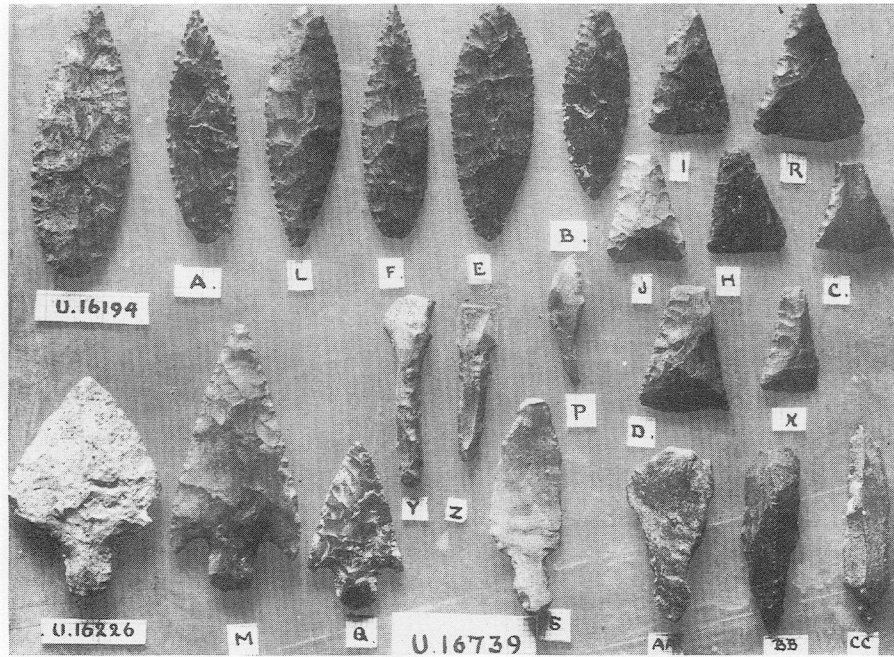

a. U.16194, 16226, 16739. Arrowheads. Scale  $\frac{4}{5}$ .

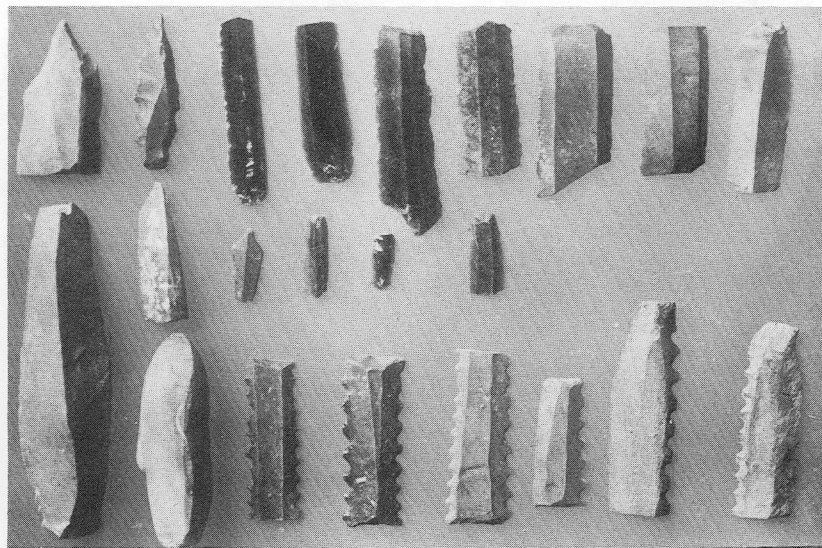

b. Flint and obsidian flake instruments. Scale  $\frac{4}{5}$ .

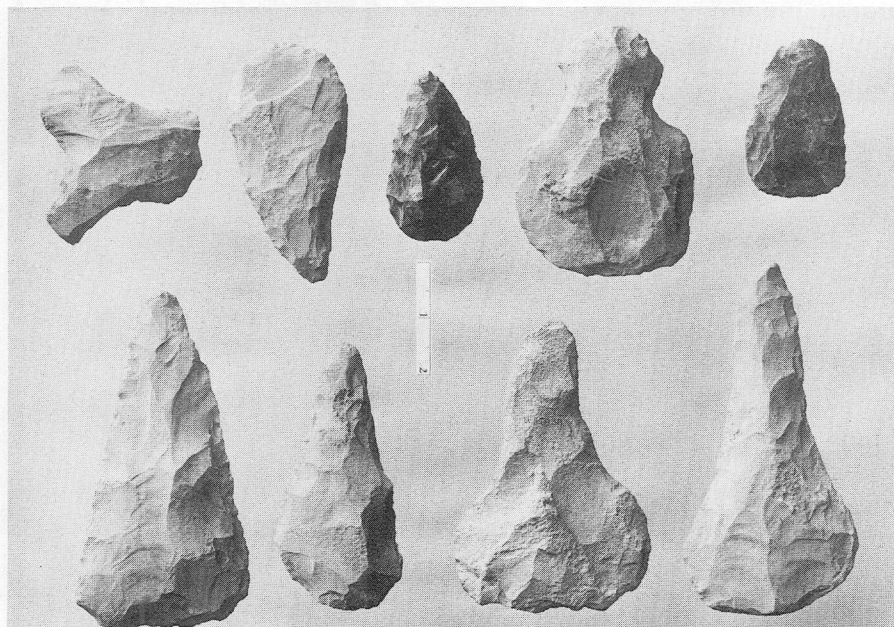

c. U.18721. Flint hoes from Reijibeh X. V. pp. 8, 14, 84.

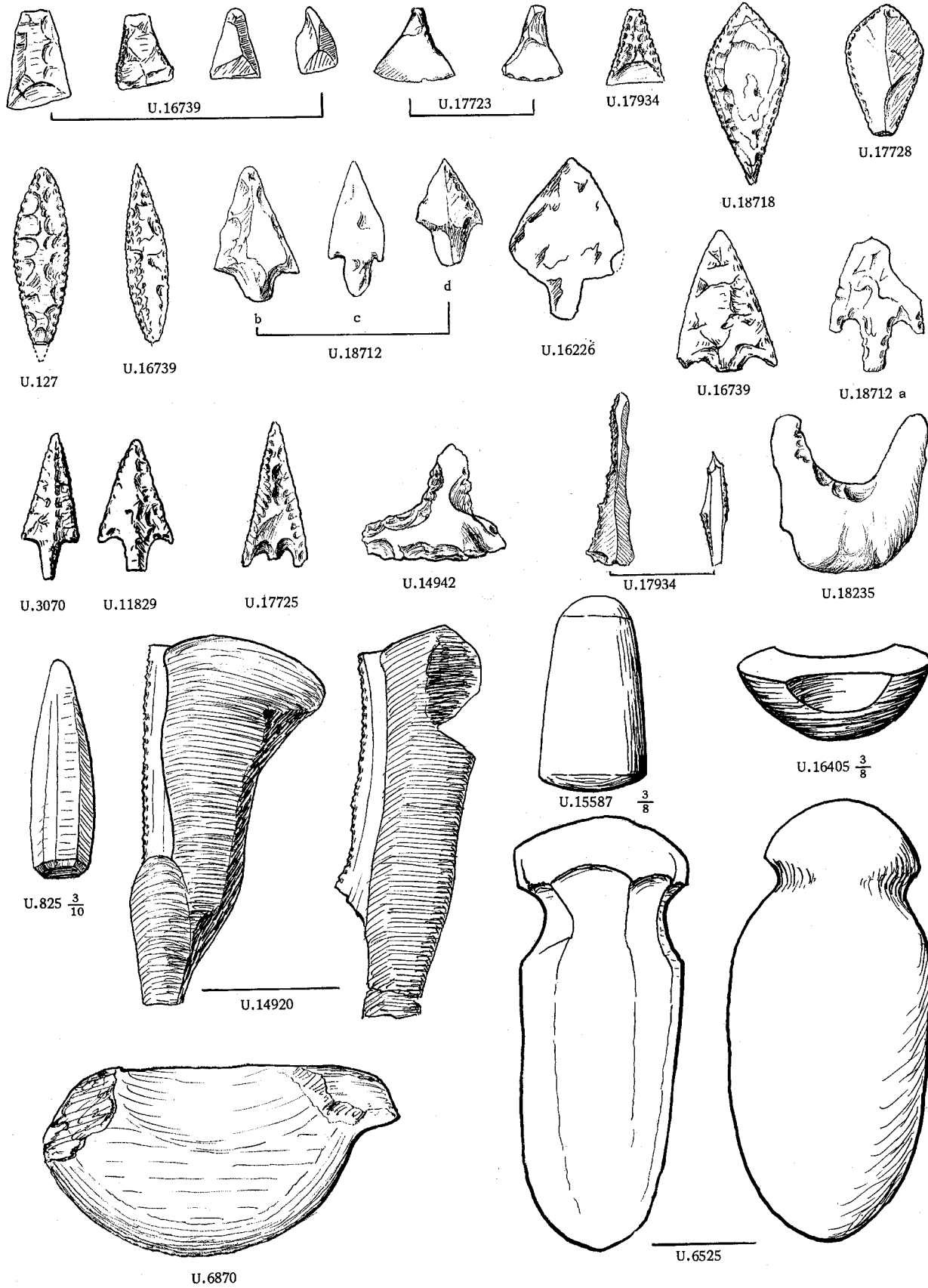

FLINT AND STONE IMPLEMENTS

Scale  $\frac{3}{4}$  unless otherwise stated

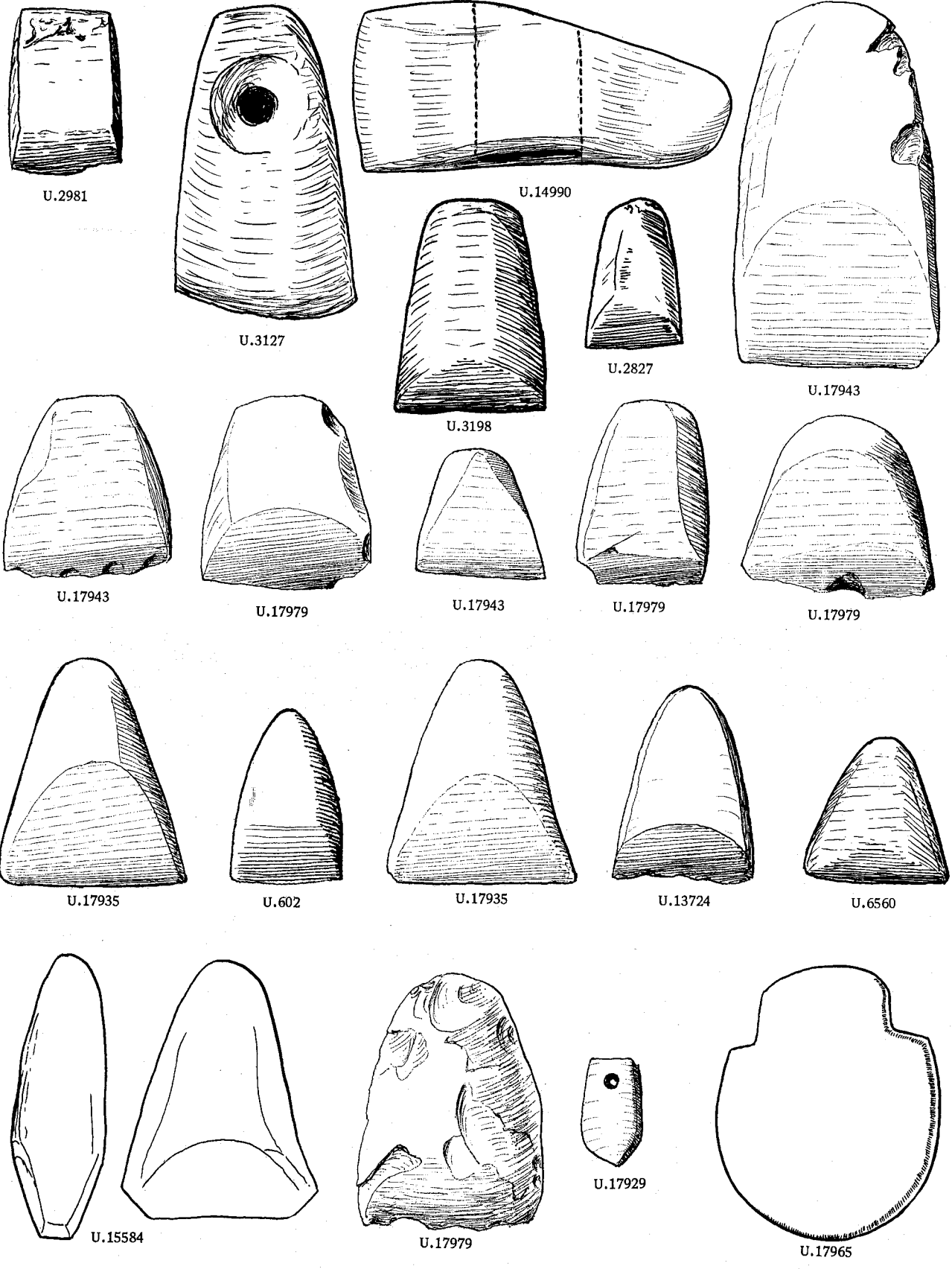

POLISHED CELTS

Scale  $\frac{3}{4}$



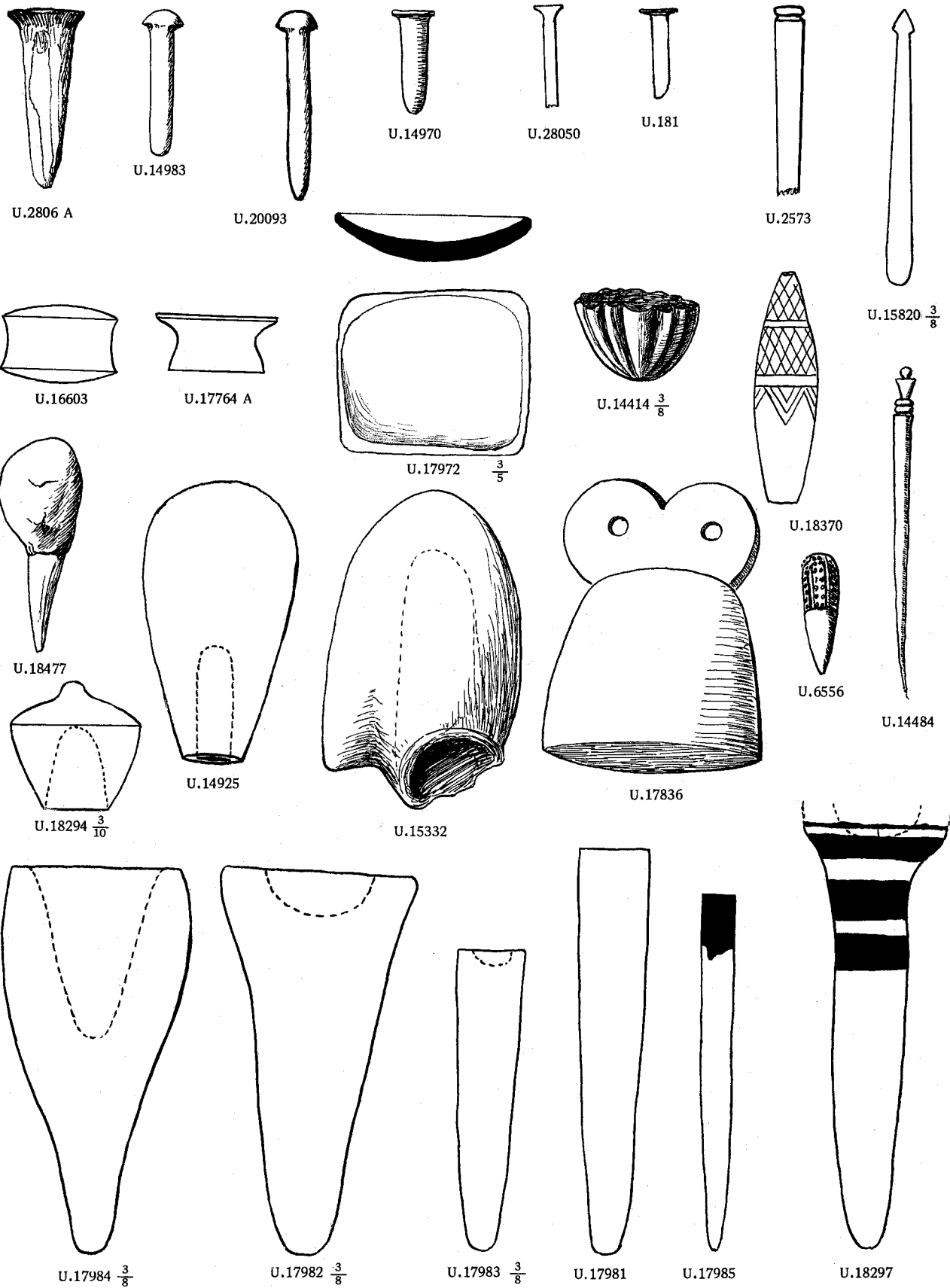

SMALL OBJECTS IN STONE, BONE, AND CLAY

Scale  $\frac{3}{4}$  unless otherwise indicated

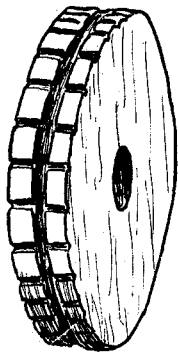

U.13719

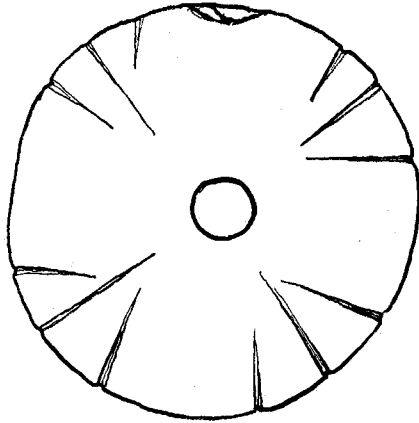

U.13749

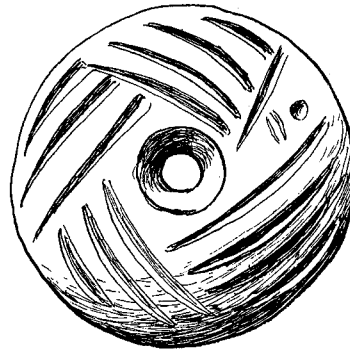

U.18194



U.17689 a

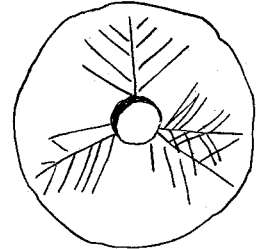

U.14464

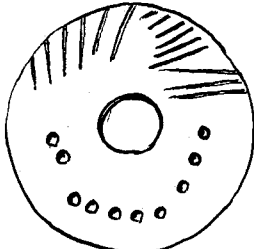

U.14931

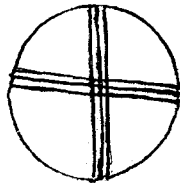

U.13733

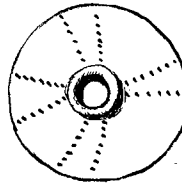

U.14946

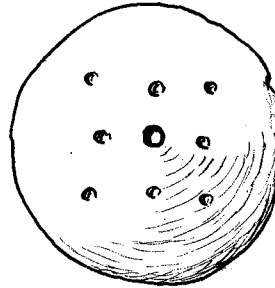

U.20080

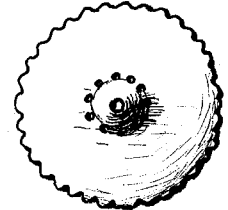

U.609  $\frac{3}{10}$

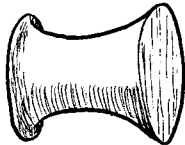

U.14466  $\frac{3}{5}$

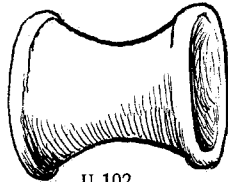

U.102

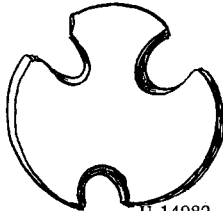

U.14982  $\frac{3}{8}$



U.14948

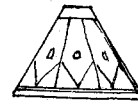

U.19129



U.14954

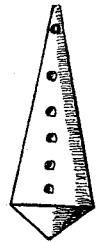

U.14482

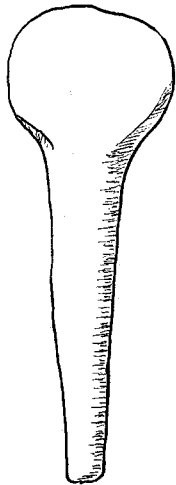

U.14462

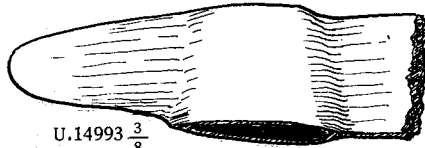

U.14993  $\frac{3}{8}$

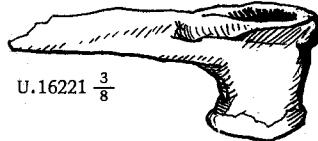

U.16221  $\frac{3}{8}$

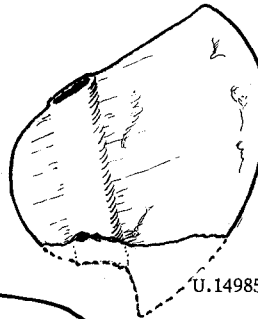

U.14985  $\frac{3}{8}$

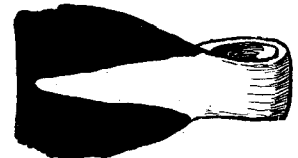

L.BM 56.9-8-136



U.17825

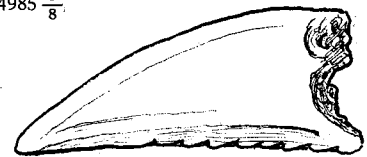

U.14408  $\frac{3}{10}$

POTTERY OBJECTS FROM THE ARCHAIC LEVELS

Scale  $\frac{3}{4}$  unless otherwise indicated



U.15505

U.15394

U.15502

U.15577

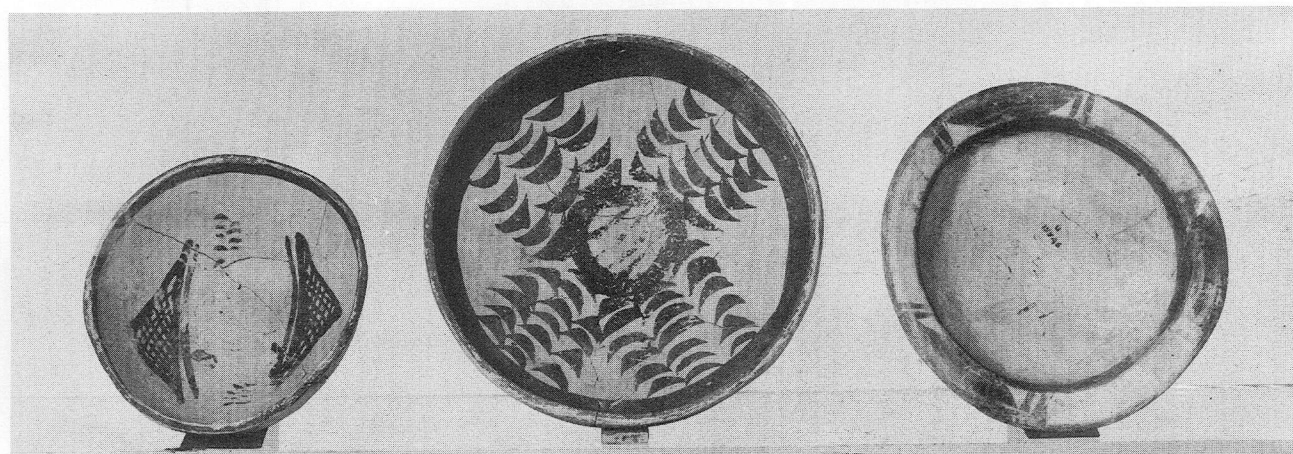

U.15533

U.15565

U.15546



U.15601

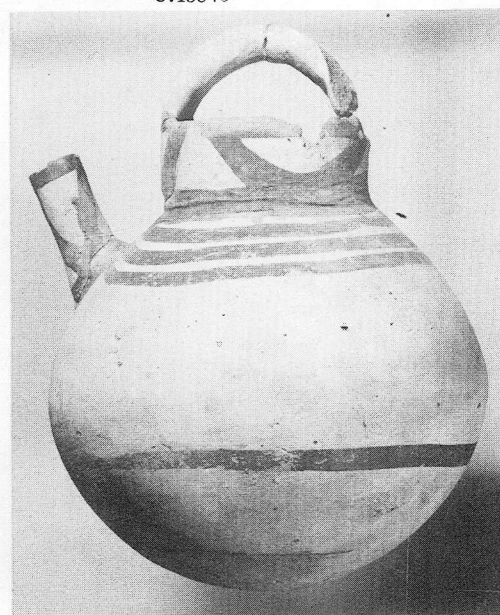

U.15377



U.15396

U.15371

U.15558



U.15592

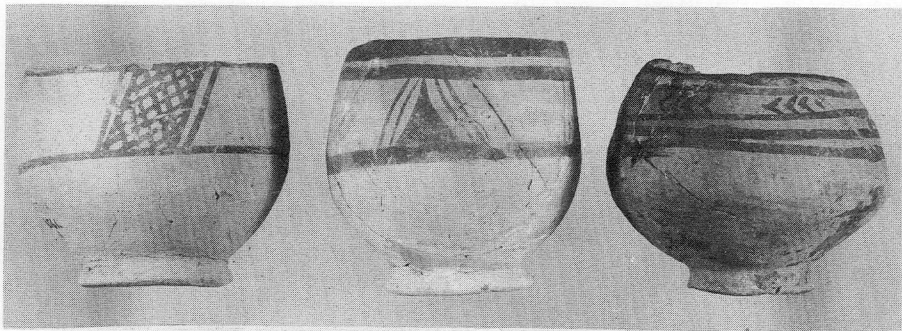

U.15384

U.15372

U.15532

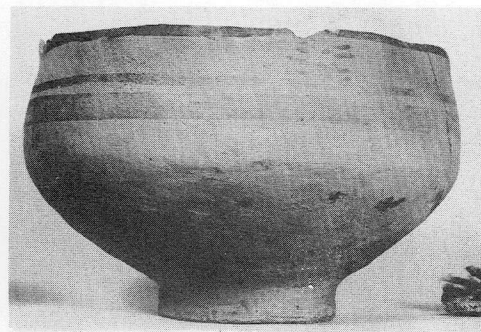

U.15383

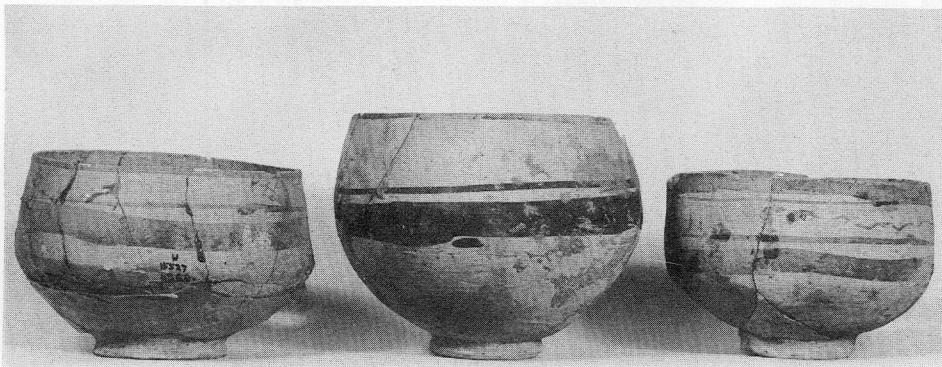

U.15527

U.15335

U.15382

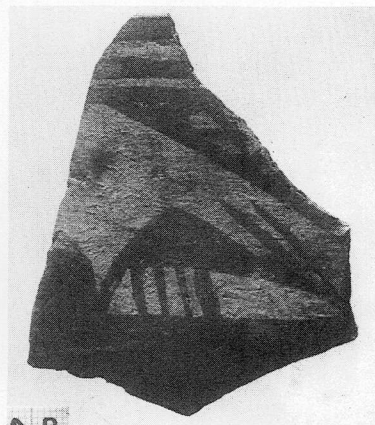

U.15595



U.15605

U.15501

U.15569

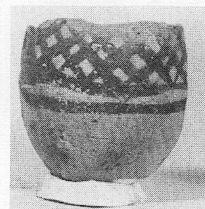

U.15504

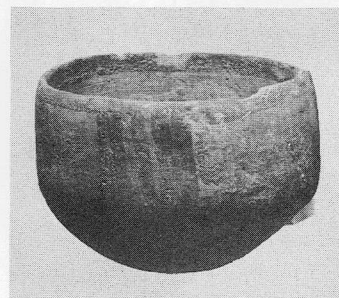

U.18624



U.15588

U.15568

U.15545

P.31-17-318

U.15539

U.15537



U.15390

U.15518

U.15571

U.15602

U.15552

U.15549

U.15631

U.14988

U.15614

U.15387

U.15395

U.15607

U.15508

U.15526

U.15593



U. 15385



U. 15379



U. 15507

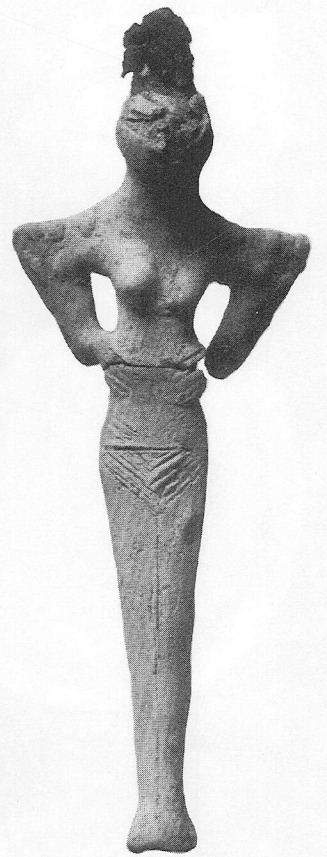

U. 15380



U. 15506

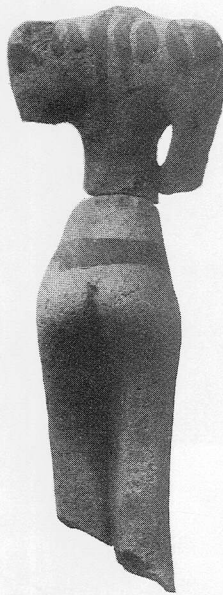

U. 15356 A-B

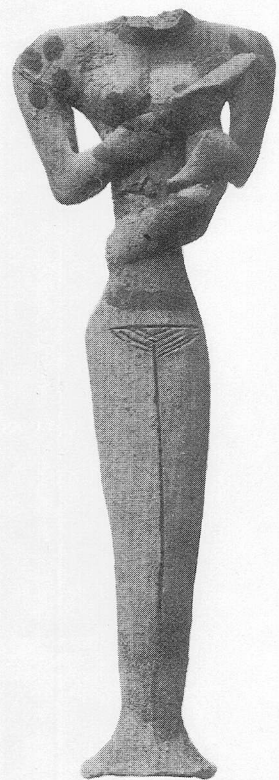

U. 15376

CLAY FIGURINES, AL 'UBAID I-II



U.1405

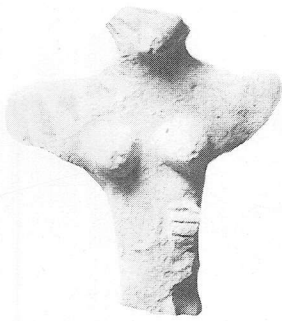

U.19976

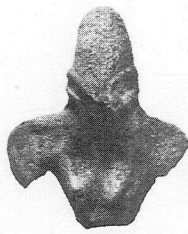

U.18169

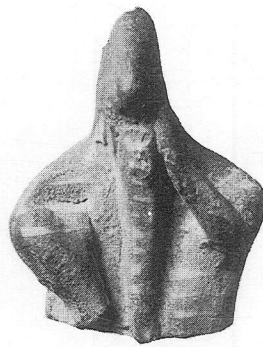

P. CBS 17199

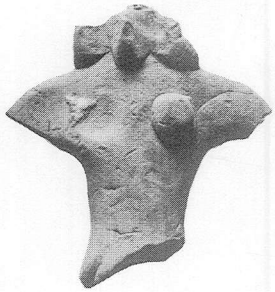
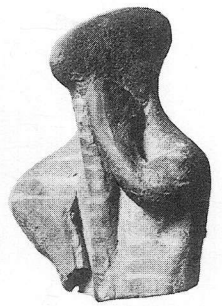

U.18417



U.18416

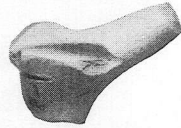

U.18528



U.18415 B

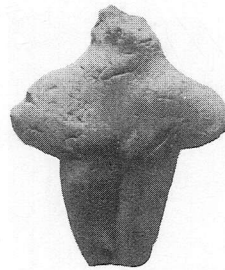

U.18415 A

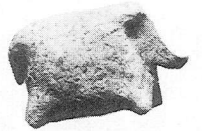

U.6170

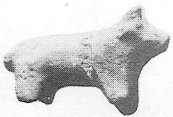

U.6419

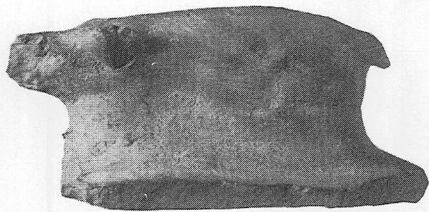

U.17620

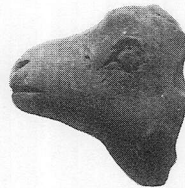

U.18423

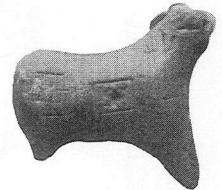

U.18390

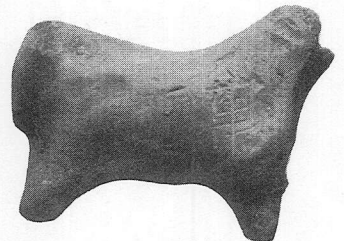

U.18391



U.2818

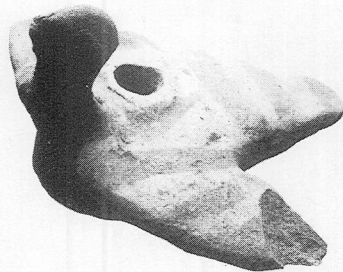

U.15362

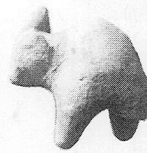

U.20061

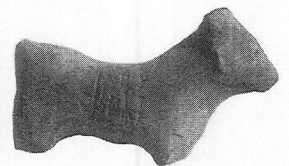

U.9549

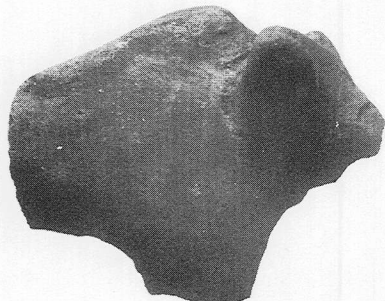

U.15354

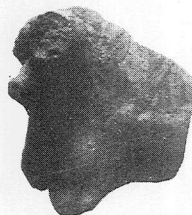

U.15612



U.19439

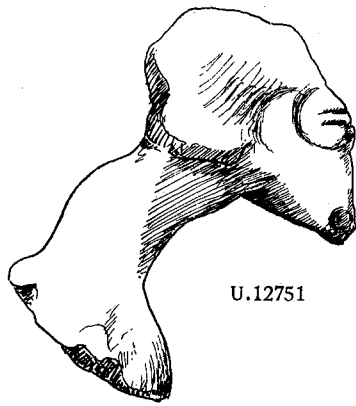

U.12751



U.15398



U.15399



U.15516

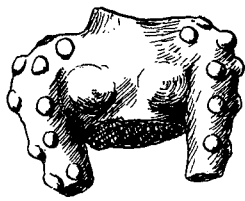

U.18629

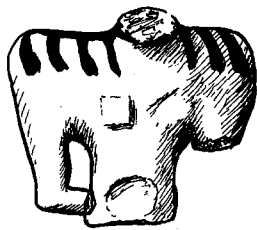

U.15356

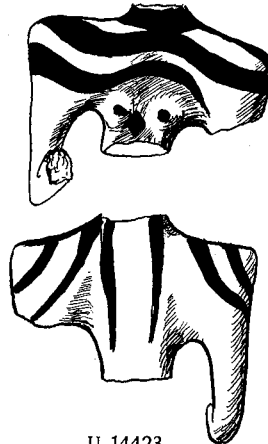

U.14423

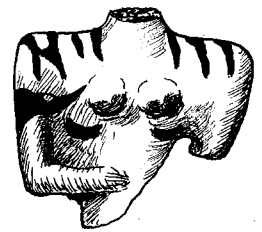

U.15331

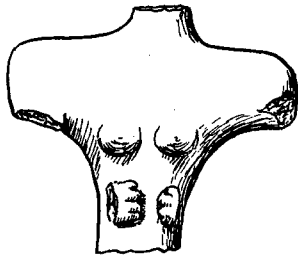

U.15603



U.15566

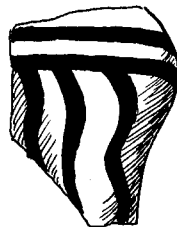

U.14436



U.14424

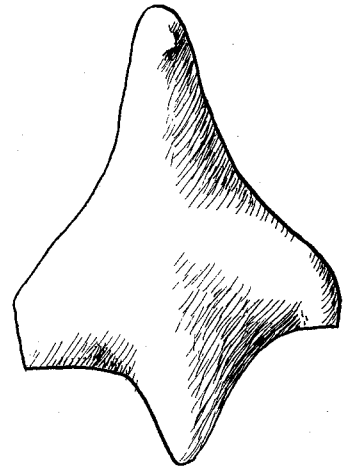

U.15355

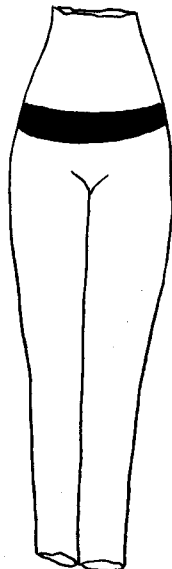

U.18527

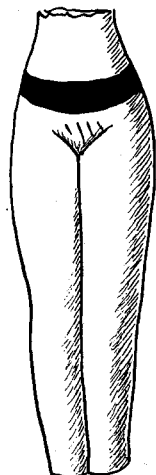

U.15349

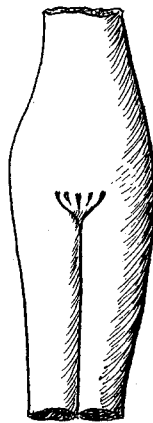

U.12770

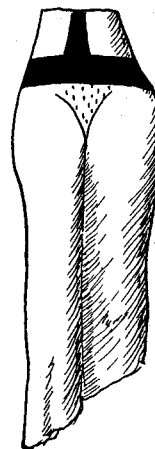

U.15356

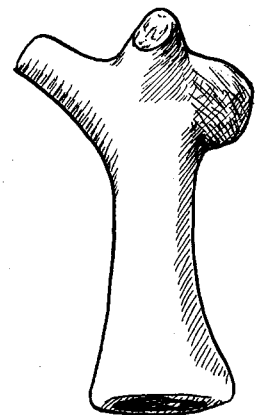

U.15358

CLAY FIGURINES OF AL 'UBAID AND URUK DATE

Scale  $\frac{3}{4}$





U.12750

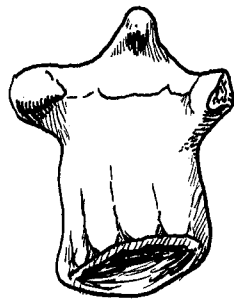

U.12500 B

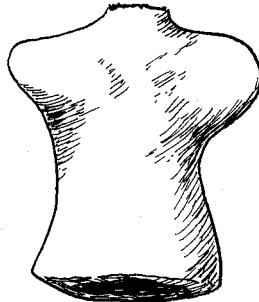

U.15334



U.12500 C



U.12500 A

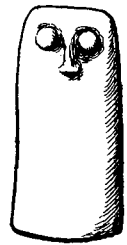

U.18323

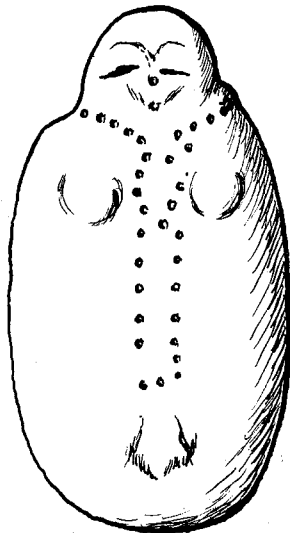

U.8640

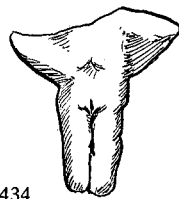
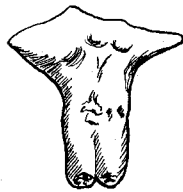

U.14434

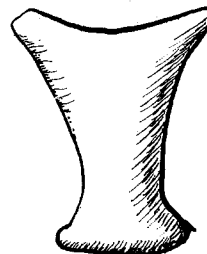

U.12500

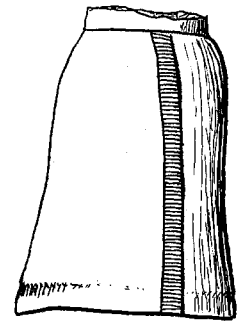

U.12764

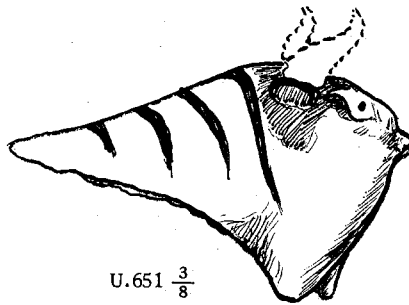

U.651  $\frac{3}{8}$



U.16111

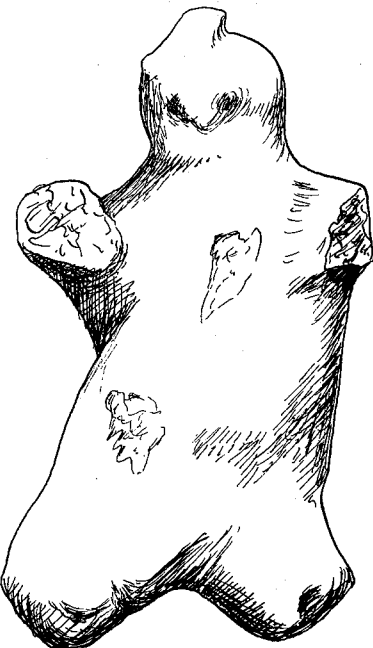

U.12749

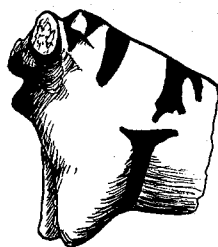

U.15612



U.7686

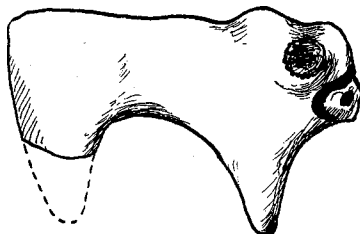

U.14995  $\frac{1}{2}$

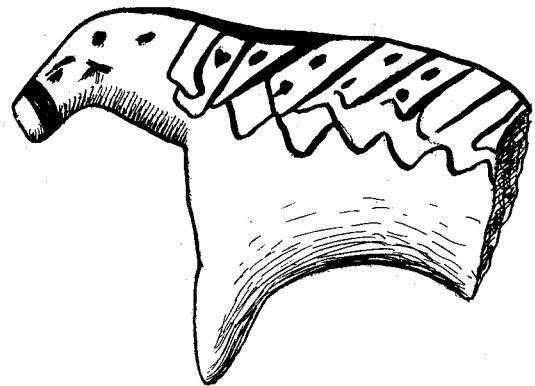

U.12772

CLAY FIGURINES OF AL 'UBAID AND URUK DATE

Scale  $\frac{3}{4}$  unless otherwise stated

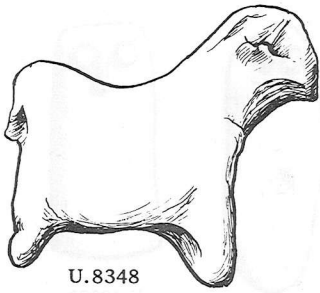

U.8348

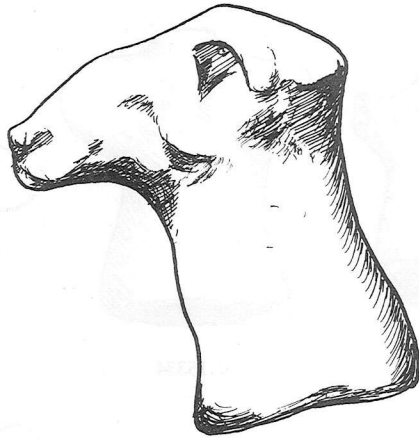

U.12752

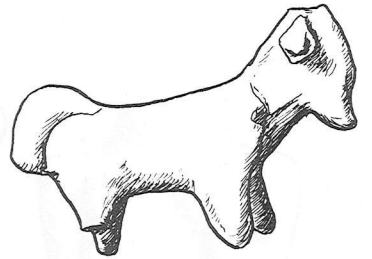

U.12759

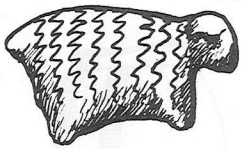

U.9322

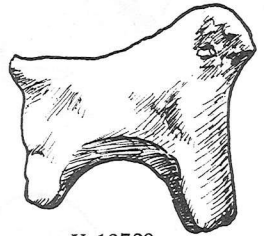

U.13720

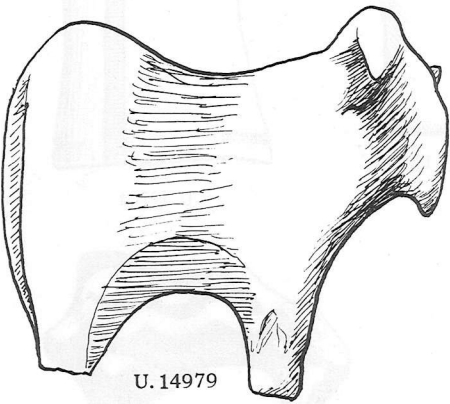

U.14979



U.13731

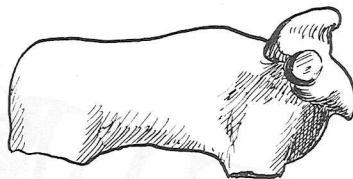

U.14994

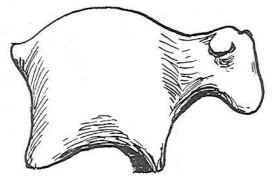

U.15324

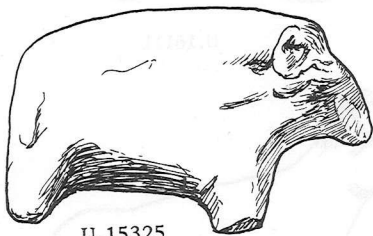

U.15325

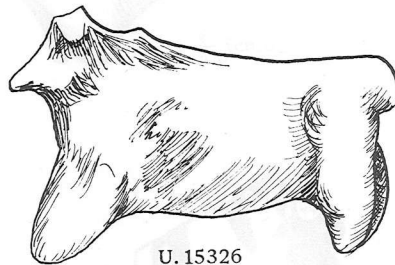

U.15326

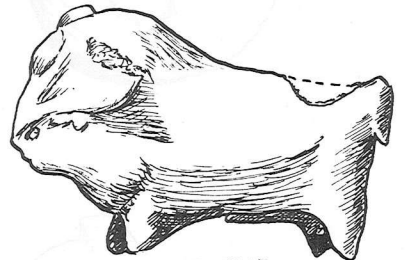

U.15347

ANIMAL FIGURINES OF URUK PERIOD. Scale  $\frac{4}{5}$

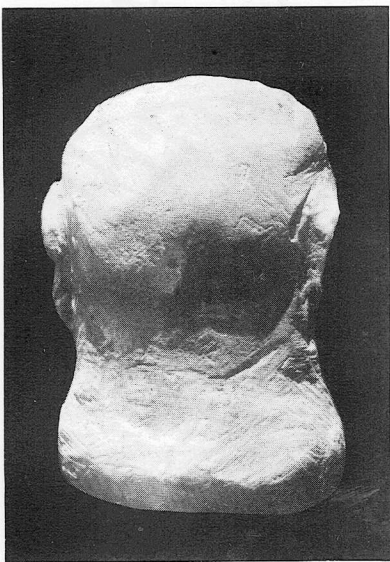

U.8472

Clay Head, Uruk Period.  
V. p. 37.



Reconstructed Chariot of Uruk Period.  
V. p. 28.

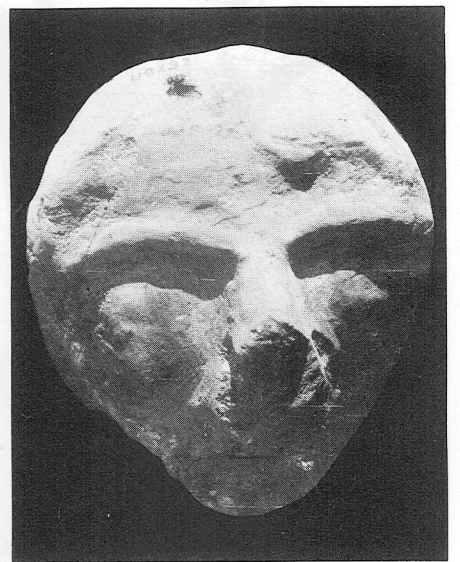

U.8292

Clay Head, Uruk Period.  
V. p. 37.



U.19350

U.20057

U.19981



U.19218

JNG/328 Type 38

U.19985

U.19980



U.18722

T.O. 521 (cf. Vol. II)

POTTERY OF THE URUK PERIOD, BLACK OR GREY WARES, RED WASHED (U.19980) AND PAINTED

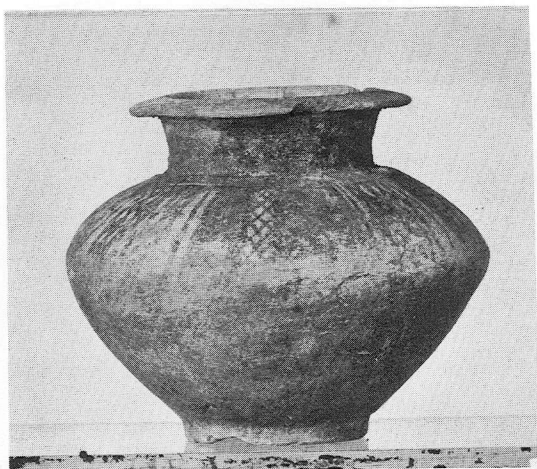

a. U.18605

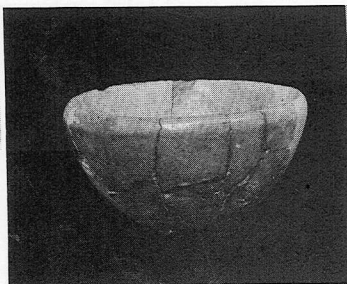

d. U.20024;  
v. e. beneath.

g. U.14908,  
Pit F, v. p. 66.



b. U.20040

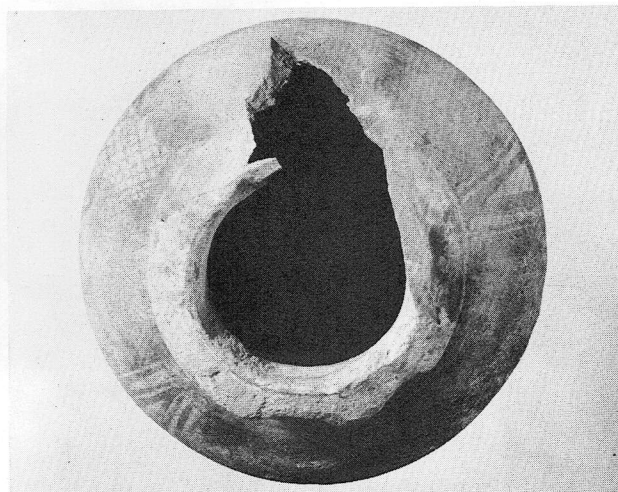

e. U.20024



c. U.19986



f. U.14909

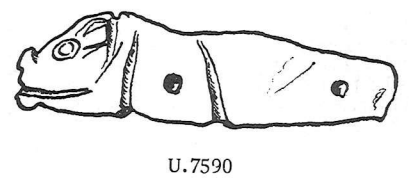
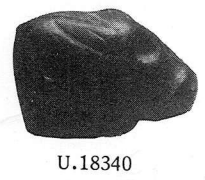
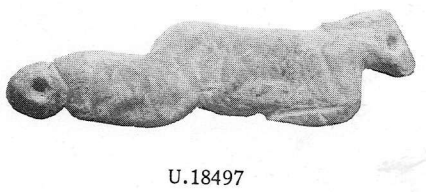
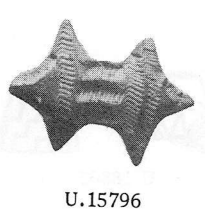
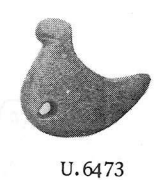
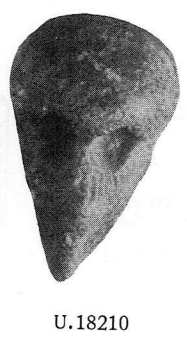
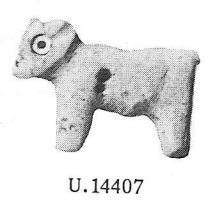
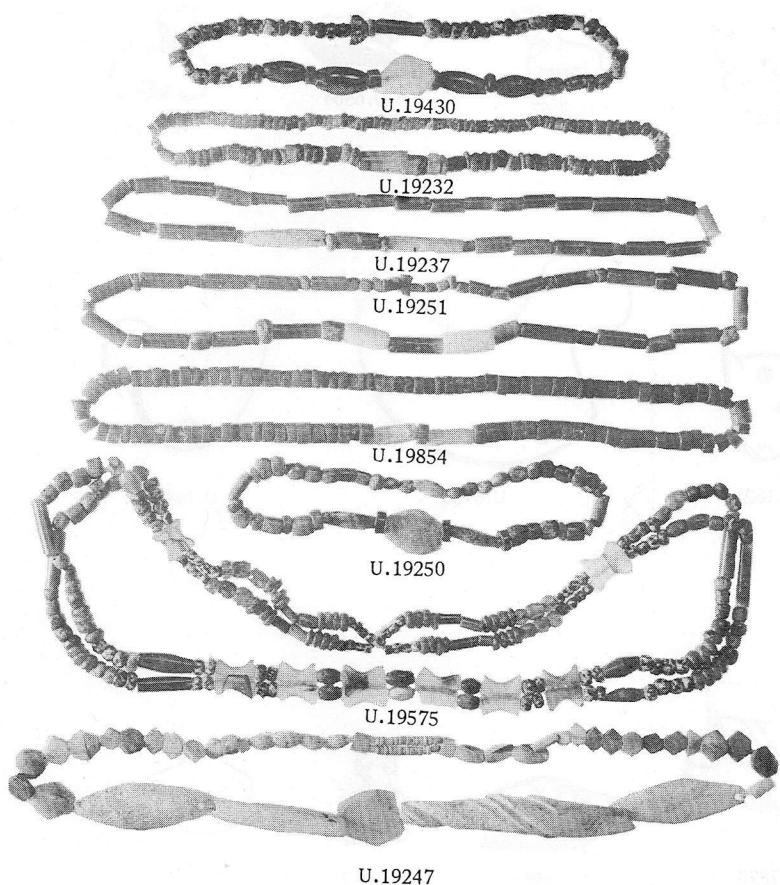

JAMDAT NASR BEADS AND STONE AMULETS OF VARIOUS DATES

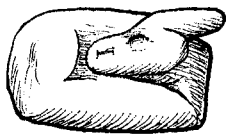

U.916



U.2509



U.1555



U.7067



U.6504



U.6486



U.3058



U.2764



U.6192



U.1621

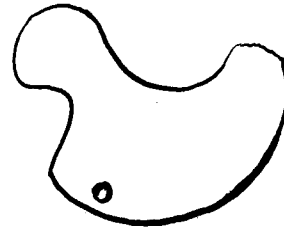

U.6468

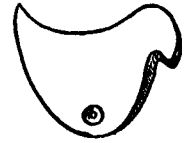

U.14494



U.17860



U.601

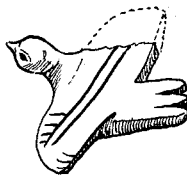

U.17870



U.16400



U.19047



U.18499



U.6487



U.14944



U.3157



U.17711

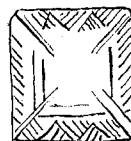

U.15323

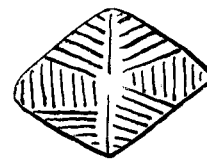

U.17923



U.15606



U.17731



U.17743



U.15357



U.13763  $\frac{6}{5}$



U.18862



U.18880



U.19021



U.19051

AMULETS, AND CARNELIAN BEADS WITH BLEACHED PATTERNS

Scale  $\frac{4}{5}$  unless otherwise stated

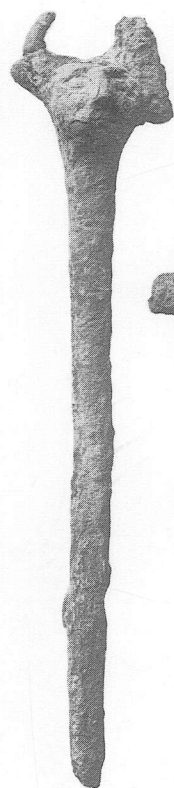

U.19102

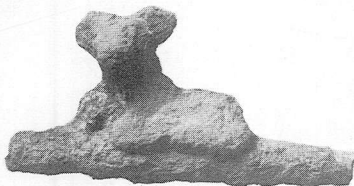

U.19101



U.19100



U.19191  $\frac{2}{5}$



U.6795  $\frac{4}{5}$

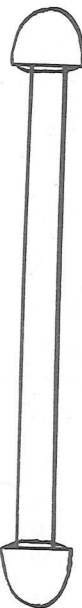

U.19020  $\frac{4}{5}$

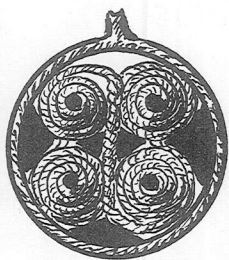

U.6797  $\frac{4}{5}$

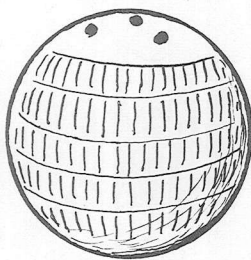

U.6800  $\frac{4}{5}$

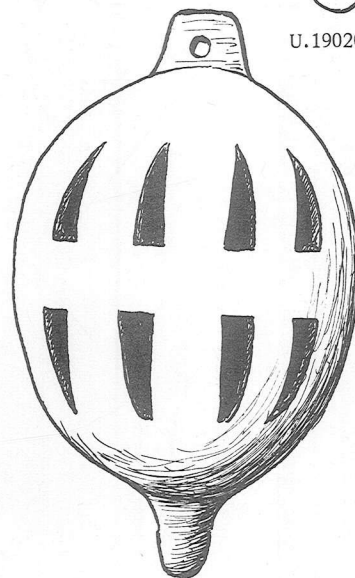

U.17879  $\frac{4}{5}$



U.19134  $\frac{1}{4}$

Copper Spouted Pan and Bowl Royal Cemetery Period, PJG/163

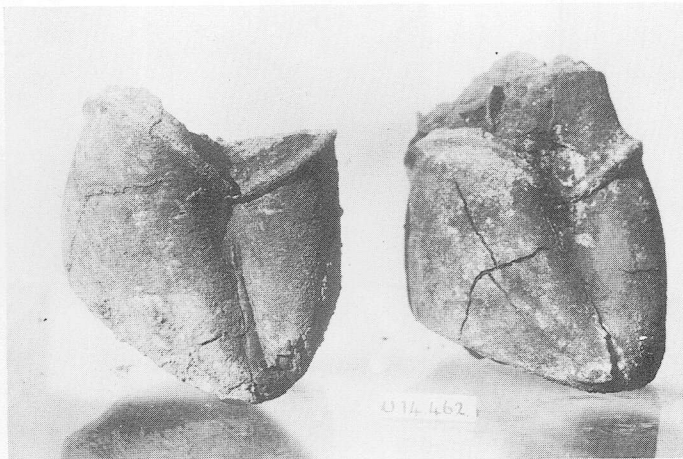

U.14462  $\frac{1}{2}$

Copper Bull's Hooves from SIS 4-5; v p. 38.

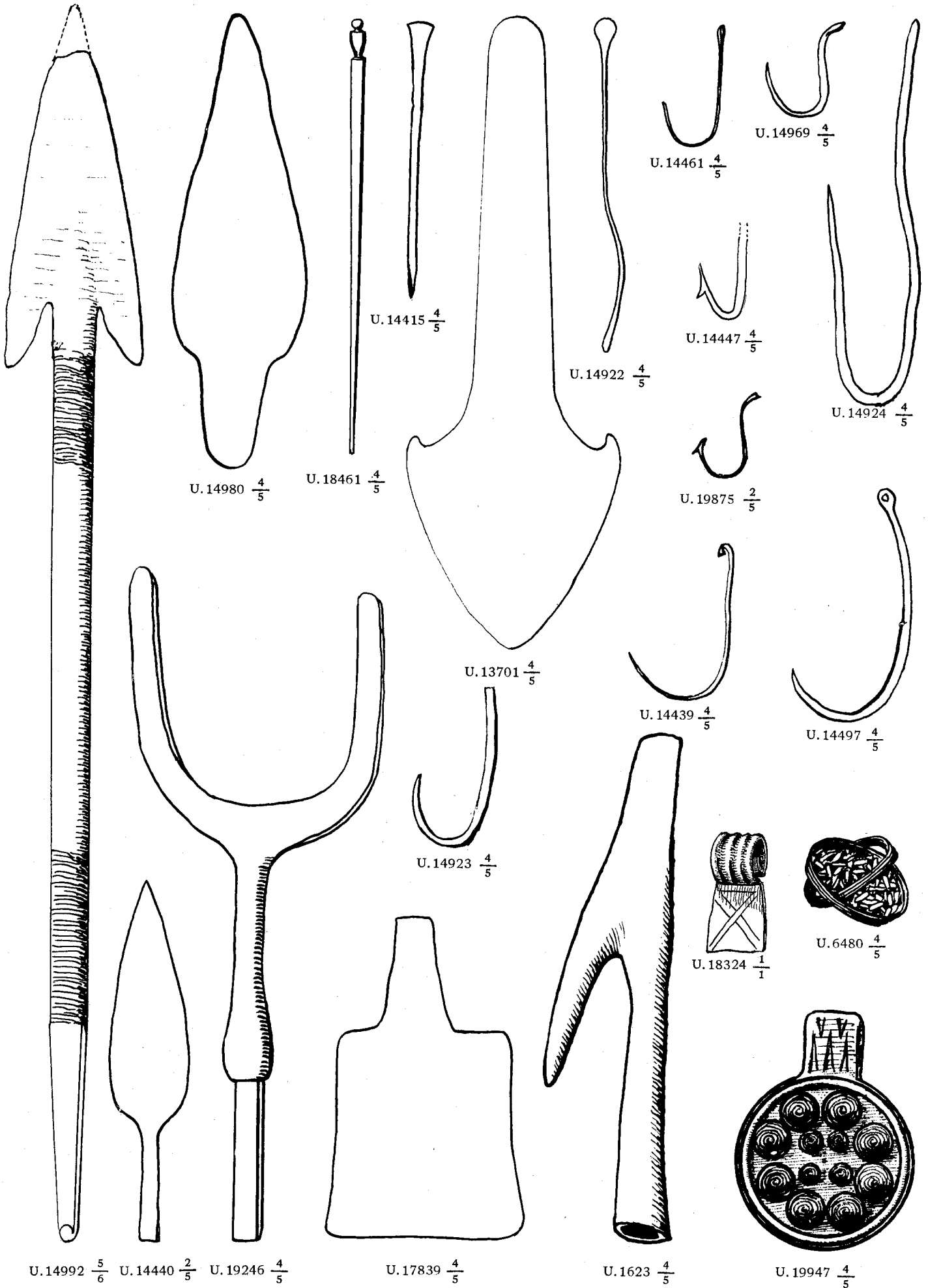

METAL OBJECTS



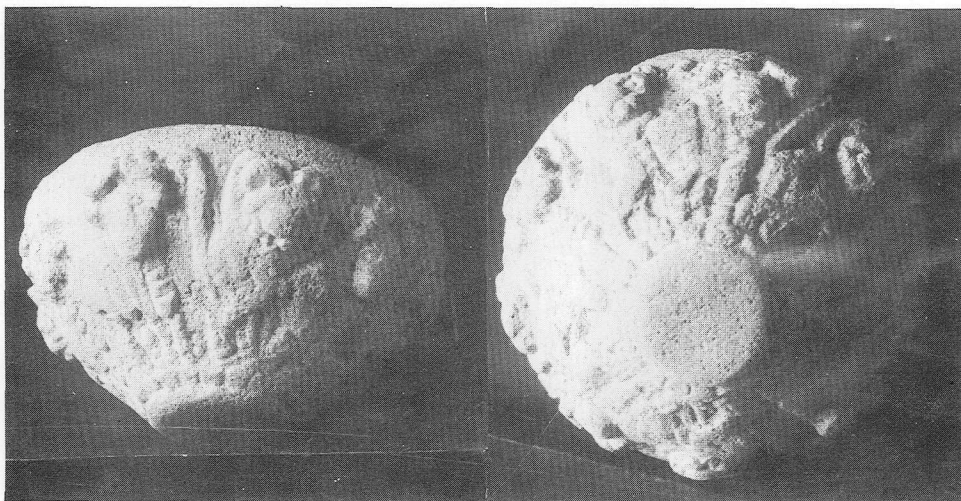

U.18524

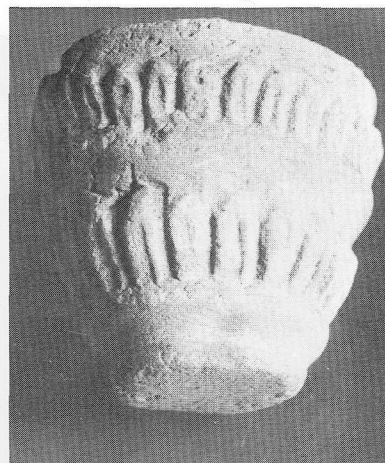

U.19378

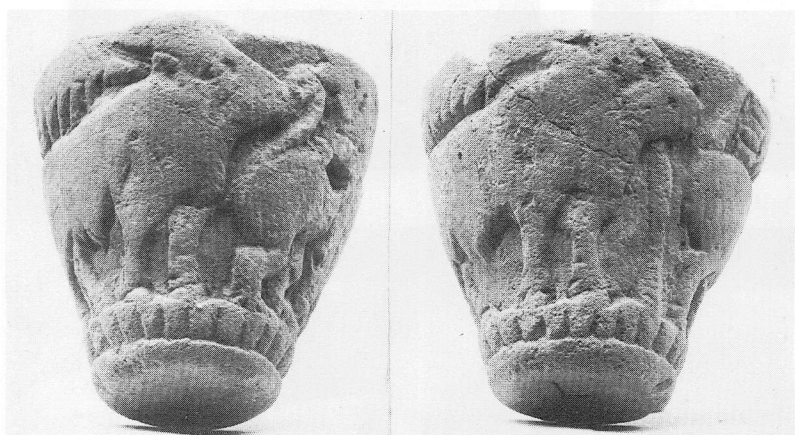

U.20000

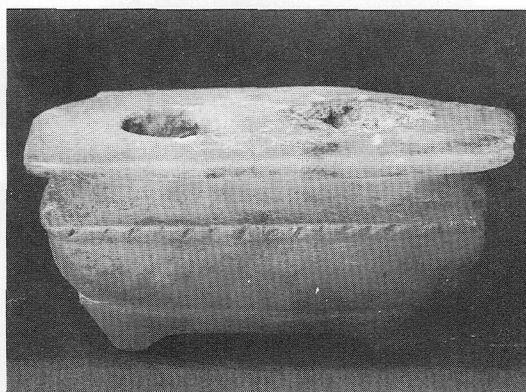

U.19428

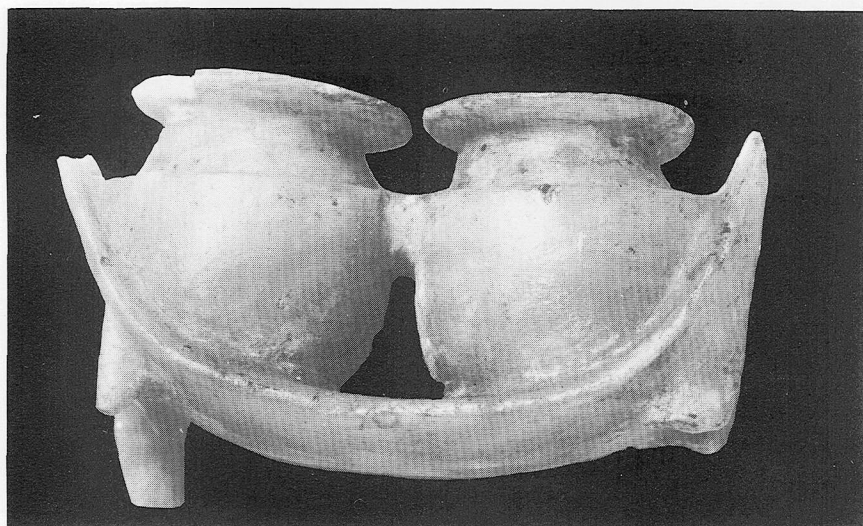

U.19529

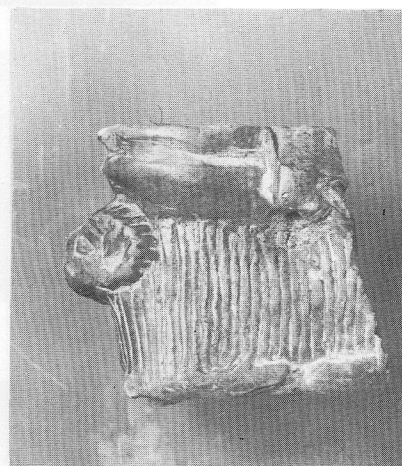

U.19426

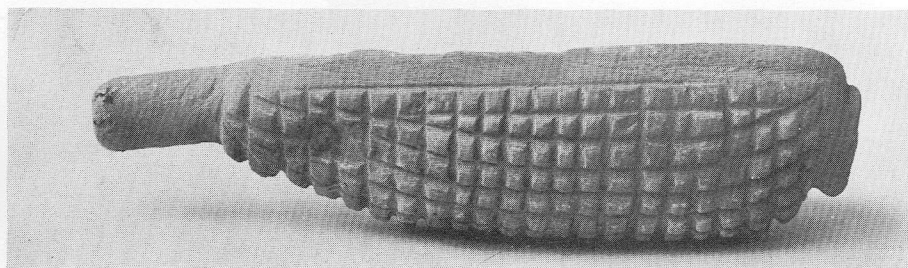

U.19744

ORNAMENTAL STONE VESSELS FROM  
JAMDAT NASR GRAVES

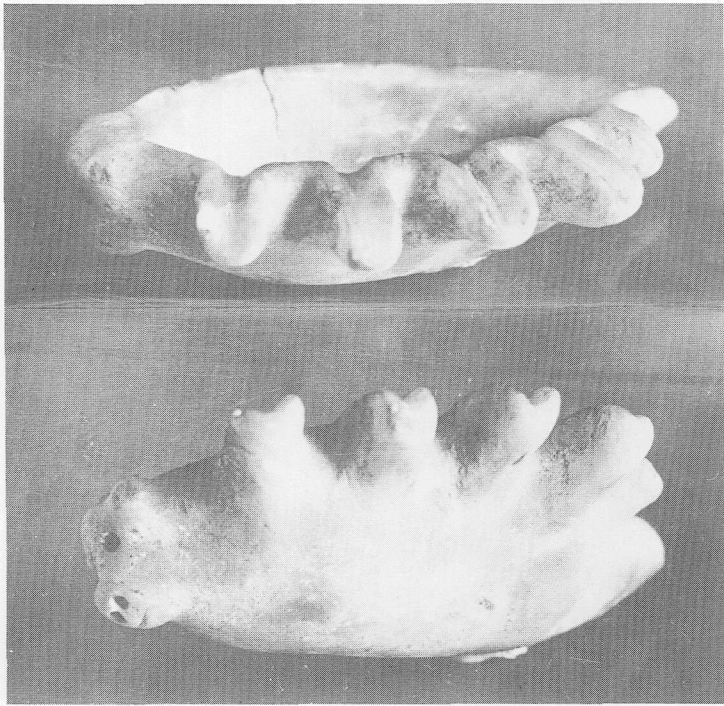

U.19745

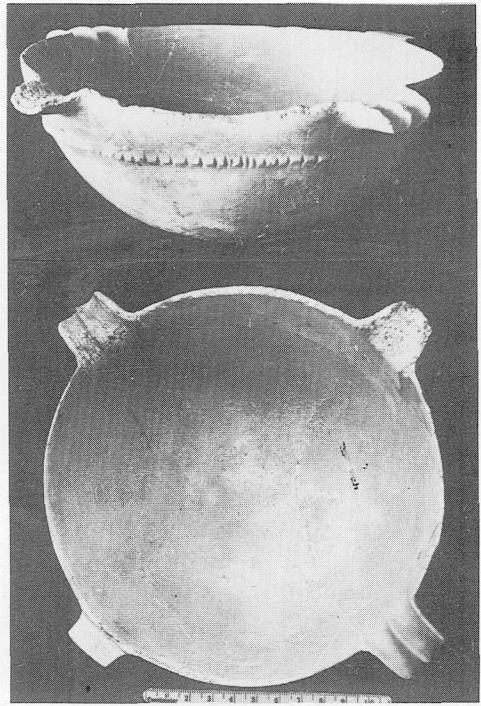

U.19885

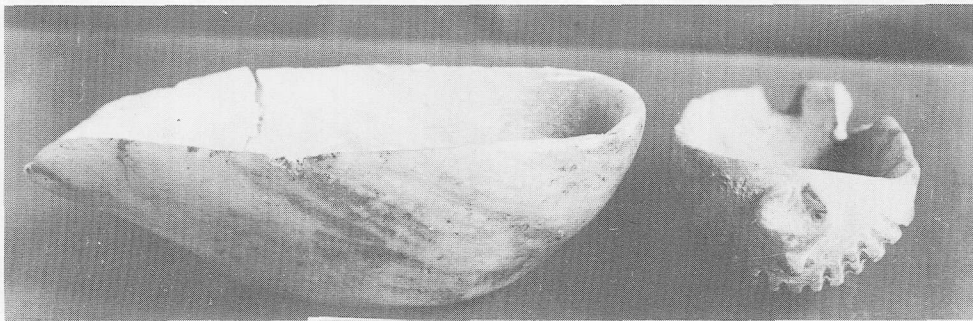

U.19770

U.19744

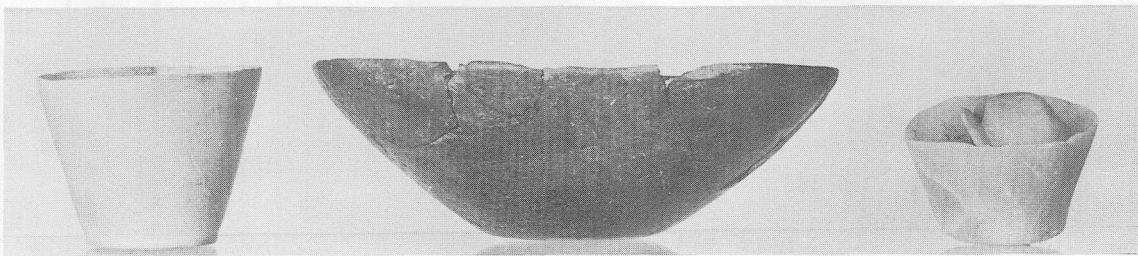

U.19436

U.19356

U.19414-5

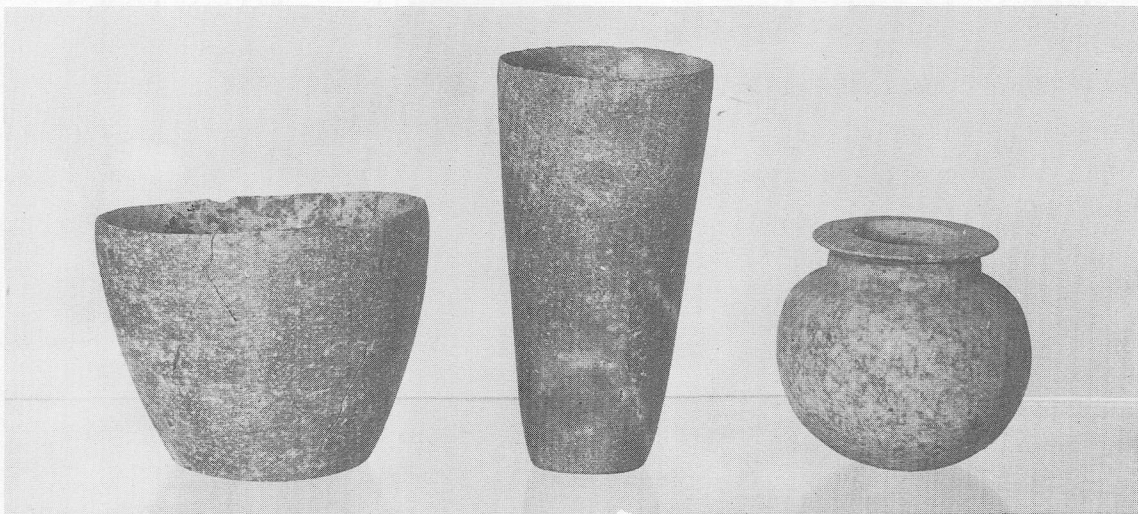

U.19319

U.19663

U.19961

STONE LAMPS AND VESSELS FROM  
JAMDAT NASR GRAVES

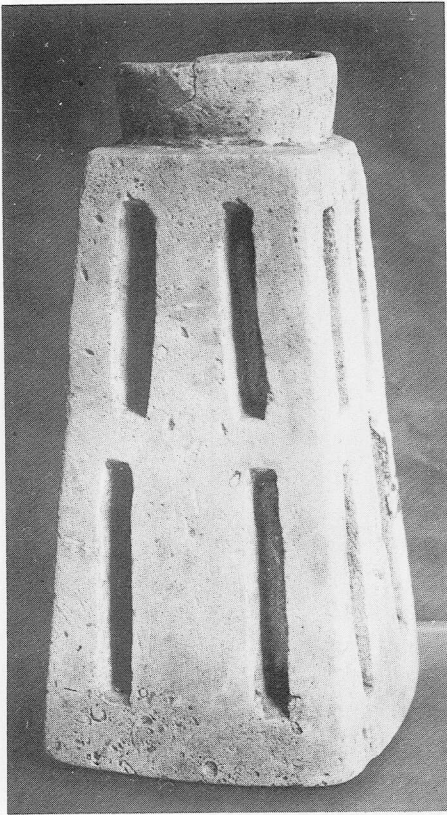

U.19593. Limestone pedestal bowl



U.19402

U.19417

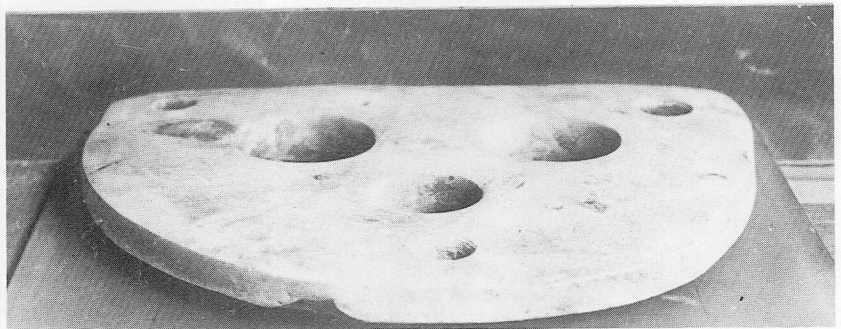

U.20056. Limestone vase-stand

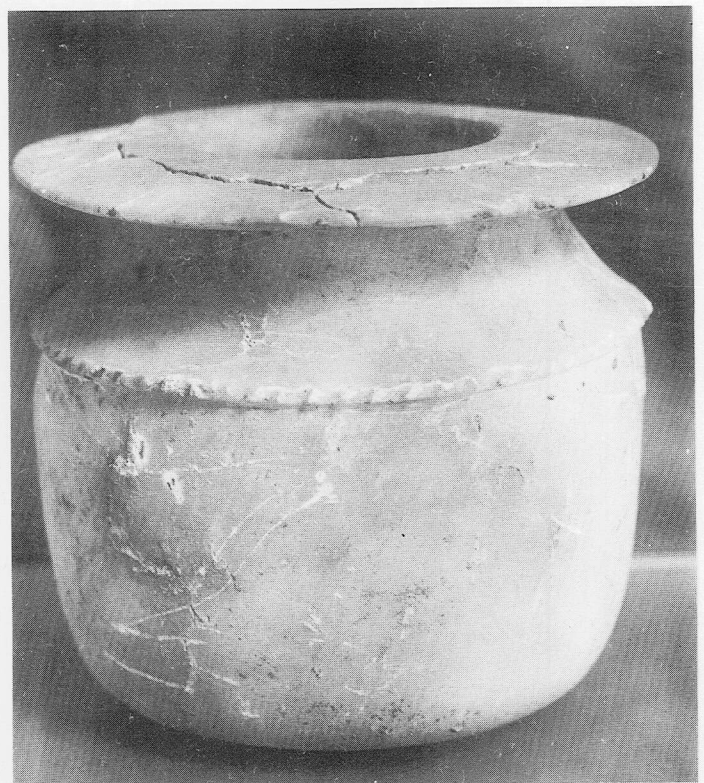

U.19401

STONE VESSELS FROM  
JAMDAT NASR GRAVES



U.19517

U.19263

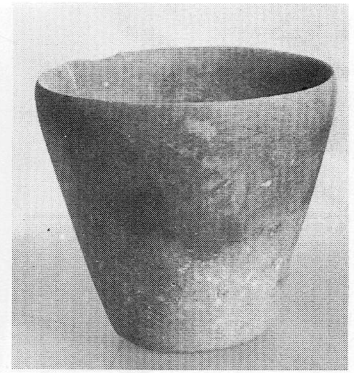

U.19265

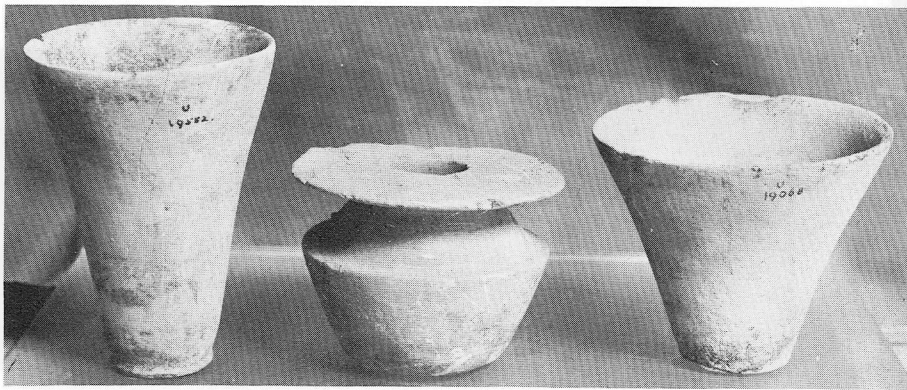

U.19552

U.19518

U.19068

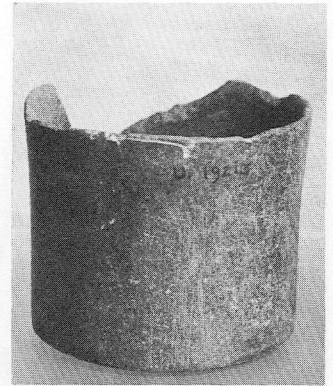

U.19213a

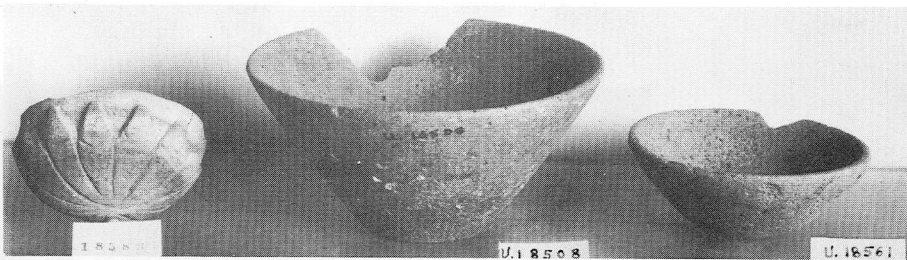

U.18558

U.18508

U.18561

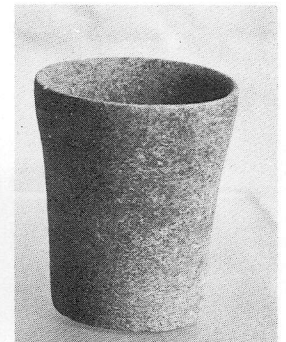

U.19513

STONE VASES FROM JAMDAT NASR GRAVES

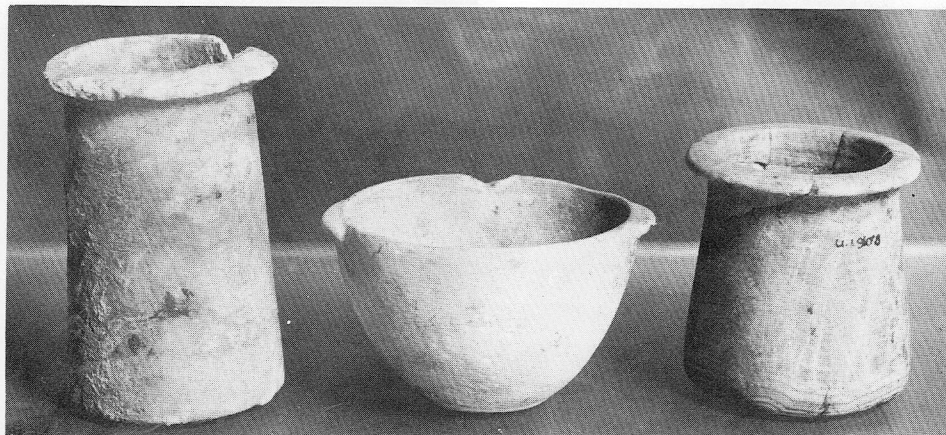

U.19015

U.19061

U.19108

STONE VASES OF ROYAL CEMETERY DATE

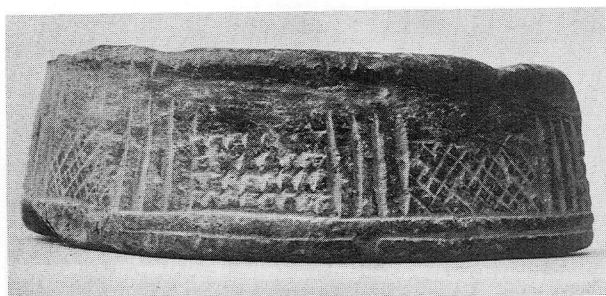

U.18865

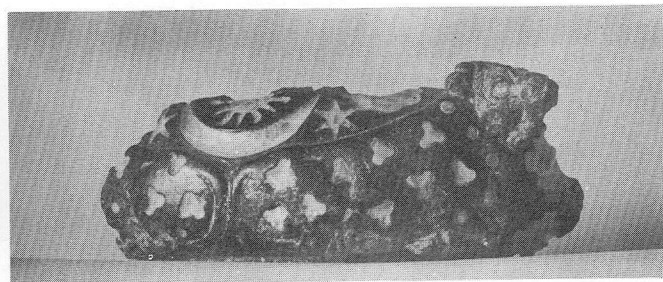

U.239. *V.* pp. 32, 52.

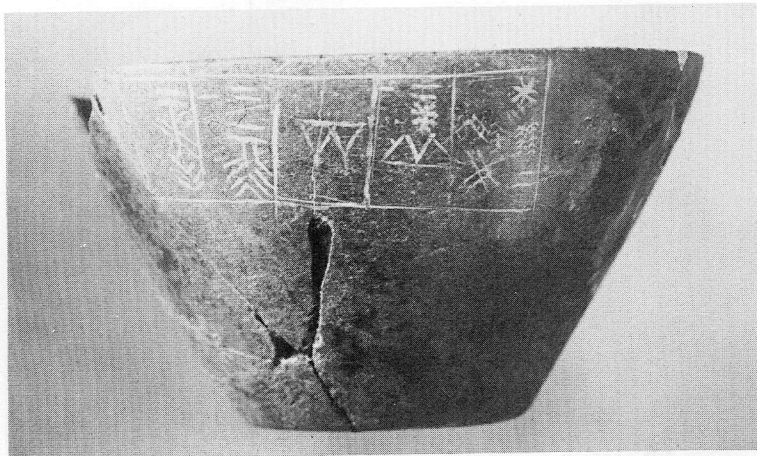

U.19241



U.224. *V.* p. 51.

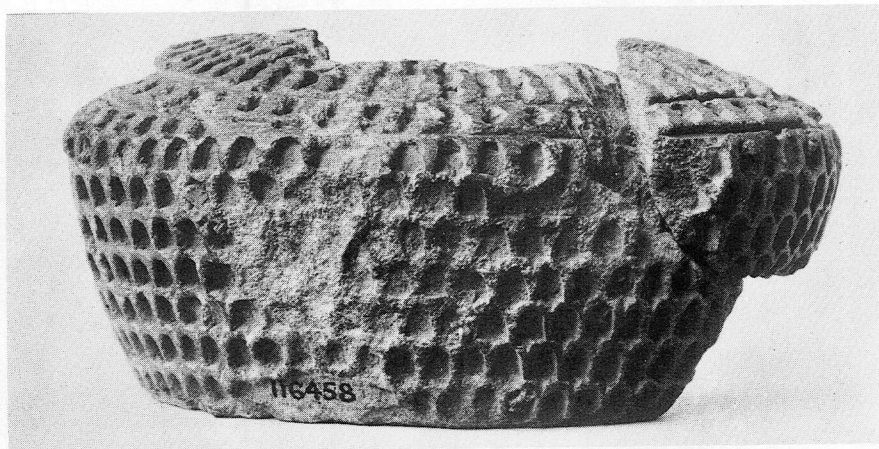

U.197. *V.* p. 32.

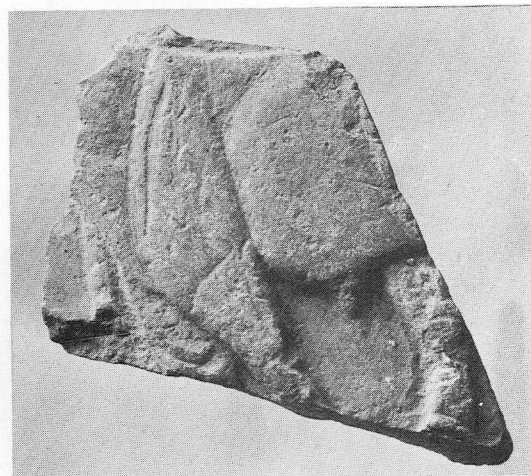

L.BM.128438

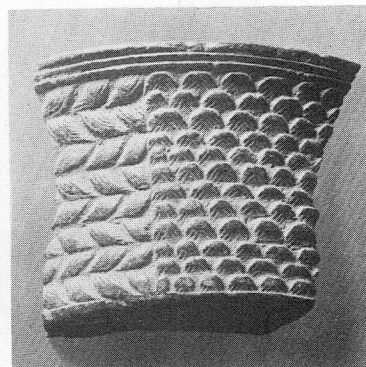

U.19085



U.18118. *V.* pp. 31, 52.



U.7145

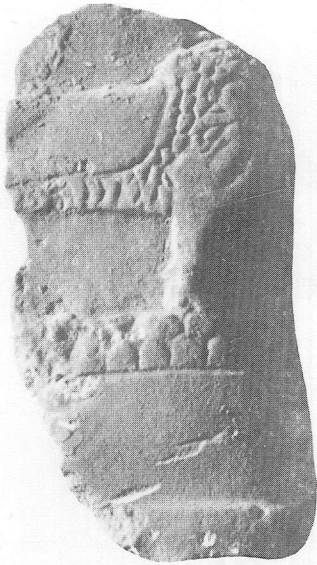

U.2638

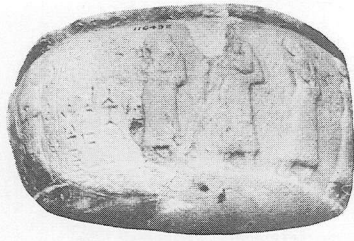

U.232

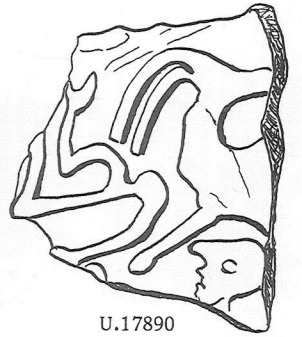
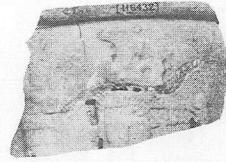

U.17890

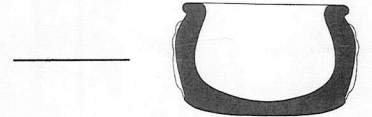
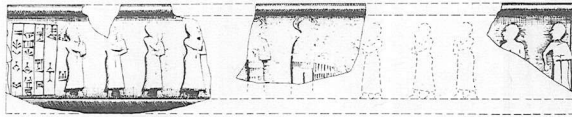

U.232. Reconstruction and section, v. p. 52 and *Ur Texts*, Vol. I, No. 7.

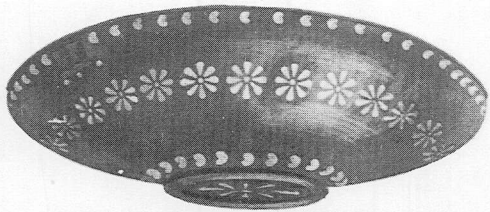

Steatite bowl inlaid with shell. Drawing restored from fragments.

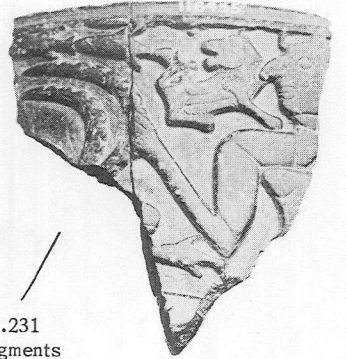

U.231  
Fragments

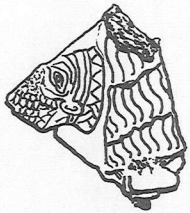

U.7072

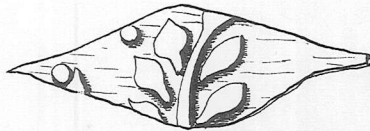

U.12768

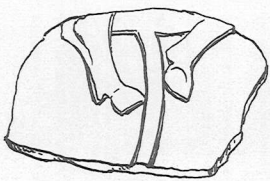

U.17077

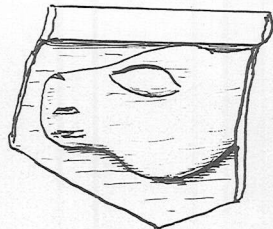

U.13052



U.231. Reconstruction and section, v. p. 51 and *Ur Texts*, Vol. I, No. 9.

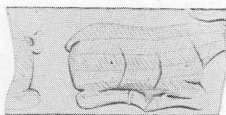
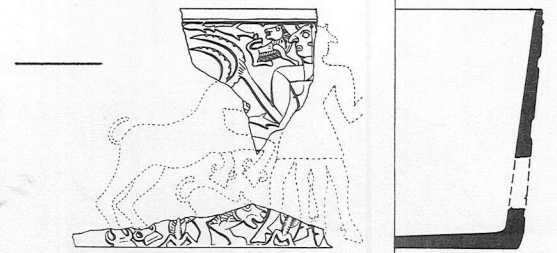

U.210



U.211

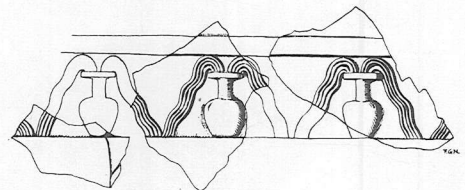

U.449  $\frac{1}{4}$



U.19037. Alabaster Statuette from the Royal Cemetery Grave PJ/B.36;  
*v.* p. 39. Scale  $c. \frac{1}{2}$ .



U.14459. Steatite Figure of a Wild Boar, from the Jamdat Nasr Level in Pit F;  
*v.* p. 31. Scale  $\frac{3}{5}$ .

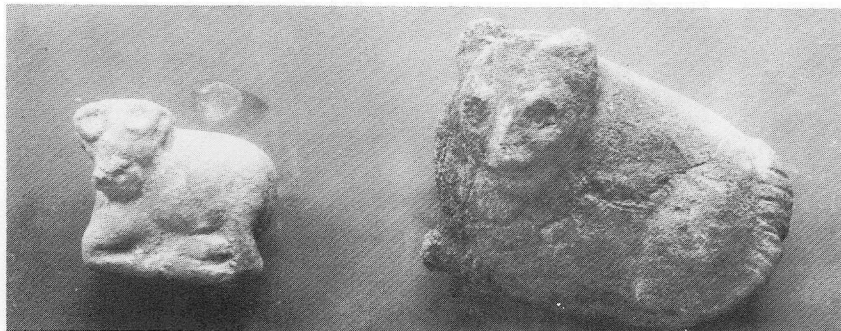

U.17834

U.17833

$\frac{4}{5}$

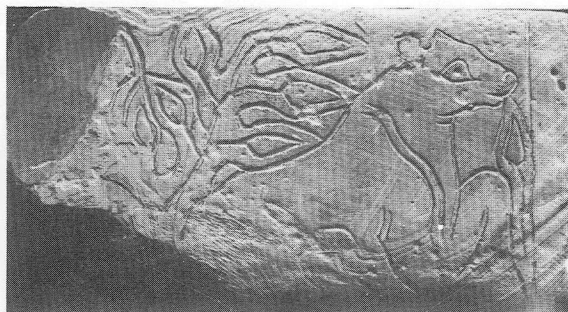

U.6596 Shell Inlay

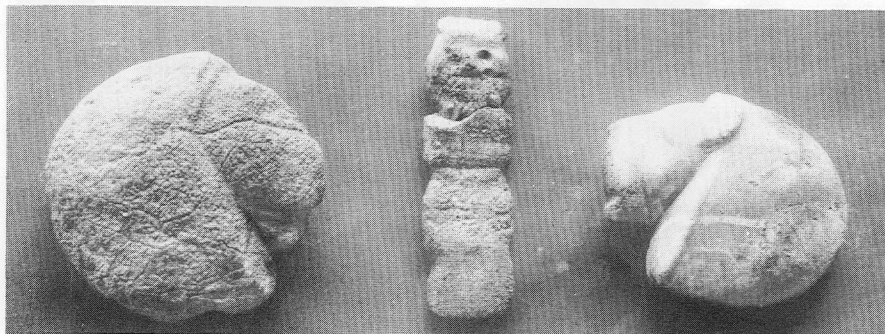

U.17835B

U.17841

U.17835A

$\frac{4}{5}$

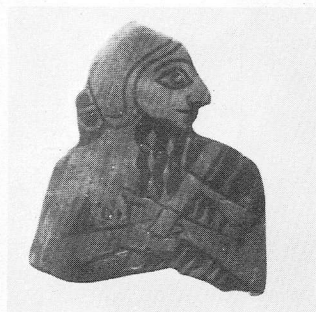

U.12326 Shell Inlay

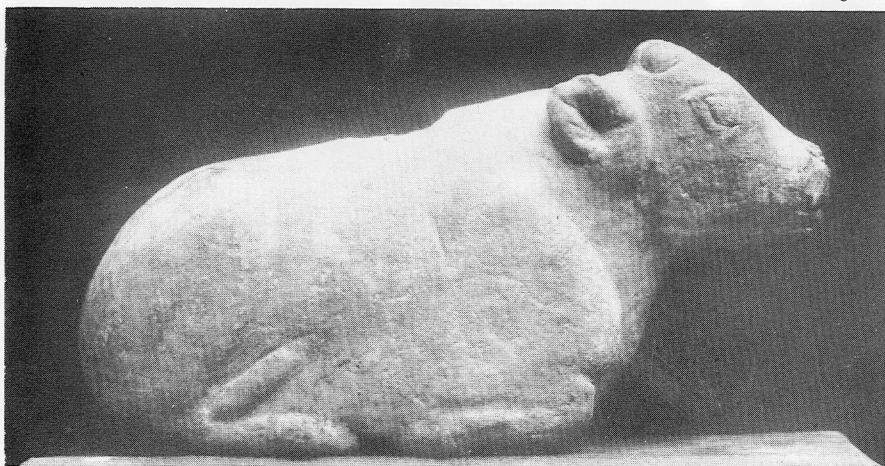

U.17832

c.  $\frac{2}{3}$

Group of Animal Figures in Calcite Found Together in a Jar; v. p. 43.



U.16245



U.2826

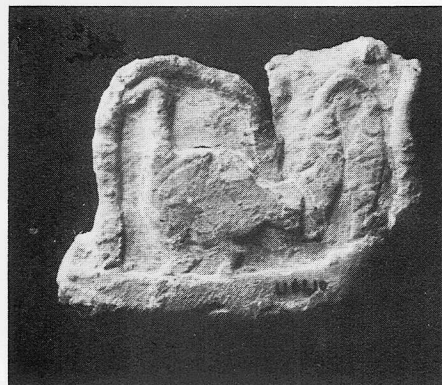
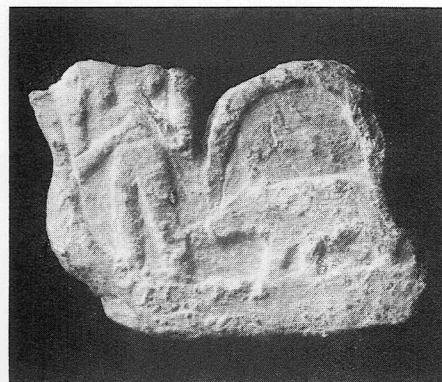

U.6410; Front and Back of Calcite Relief; v. p. 42.

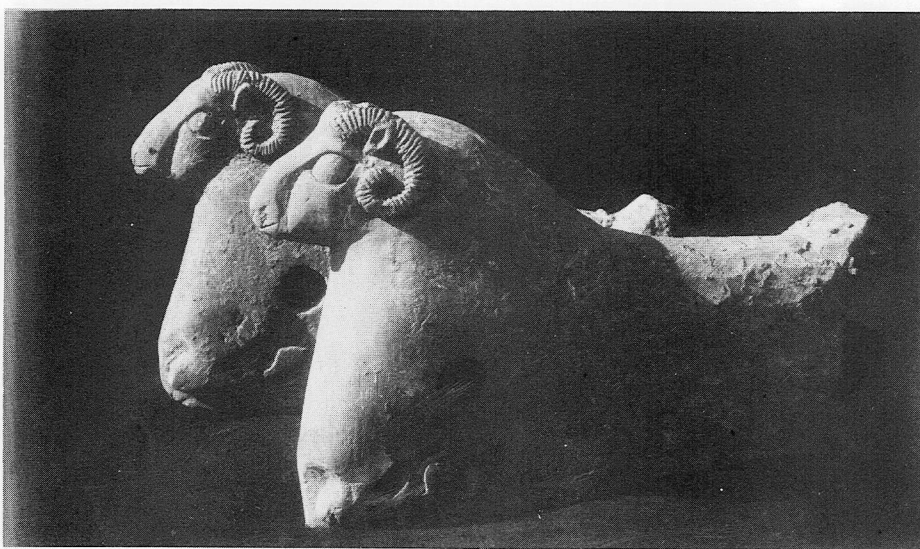

U.6756 A, B; Limestone *protomoi* of Rams Perhaps from a Throne; v. p. 42.



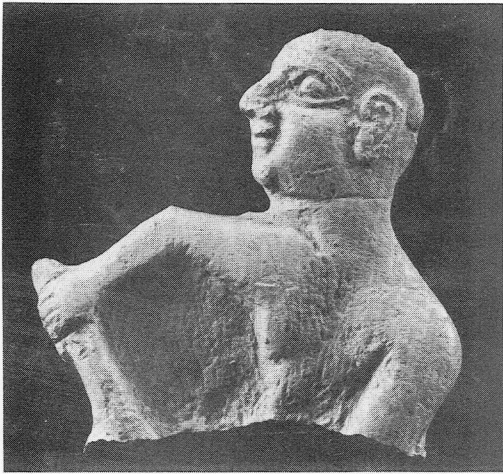

a. U. 11400



b. U. 18309



c. U. 6831. *V.* p. 45.

Scale c.  $\frac{2}{5}$

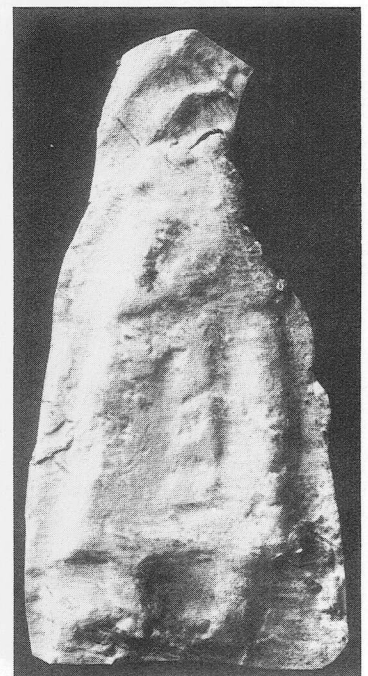

d. U. 17829. Granite Stela of Ur-Nina, front and side views (from a paper squeeze). *V.* p. 46.



U.805. Diorite Statue of Entemena of Lagash  
*V.* p. 47 and *Ur Texts* Vol. I, No. 1

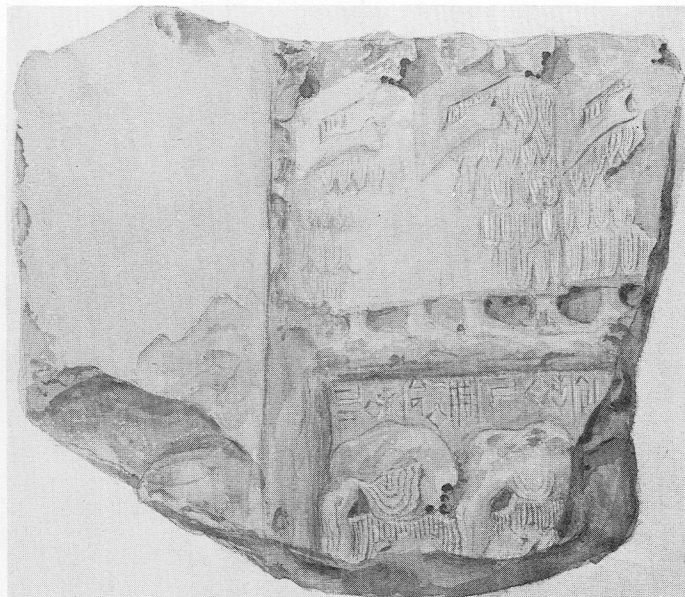
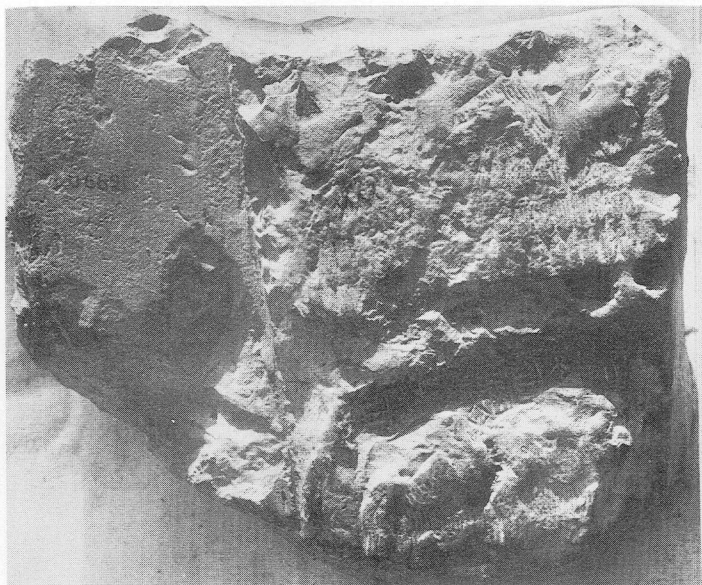

(a) U.6691. Fragments of Limestone Stela, and Drawing of Same; v. p. 46 and *Ur Texts*, Vol. I, No. 13.

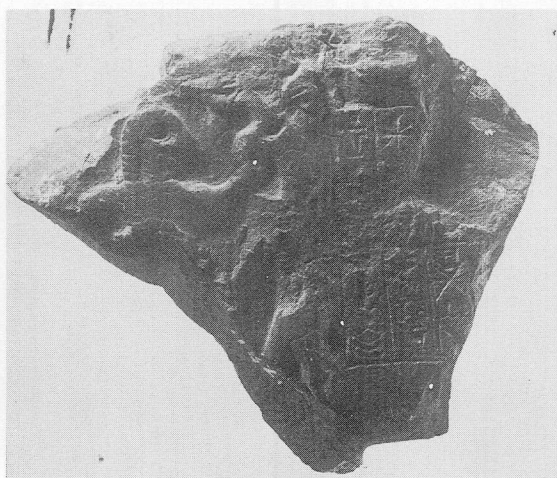

(b) U.6727. V. p. 47 and *Ur Texts* Vol. I, No. 14.

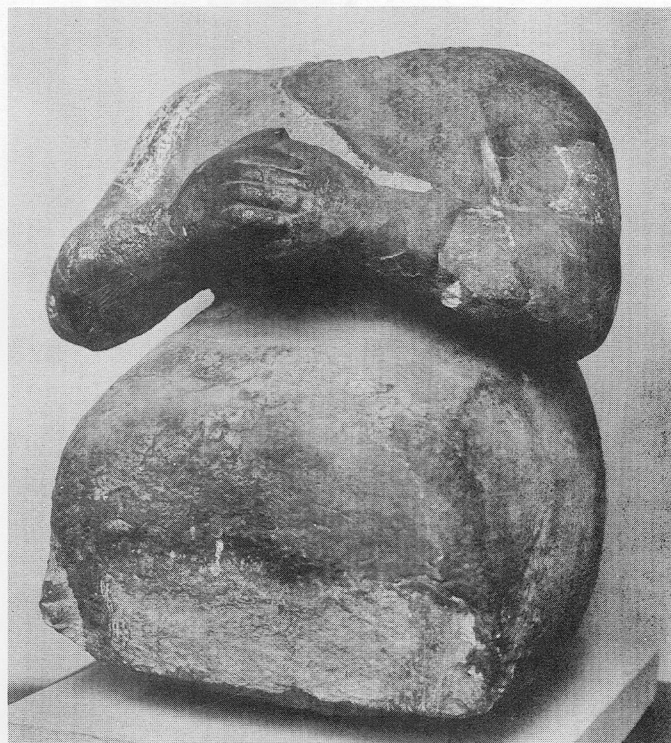

(c) U.2732. Diorite Statue of Dada-ilum (partly restored); v. p. 47 and *Ur Texts*, Vol. I, No. 11.

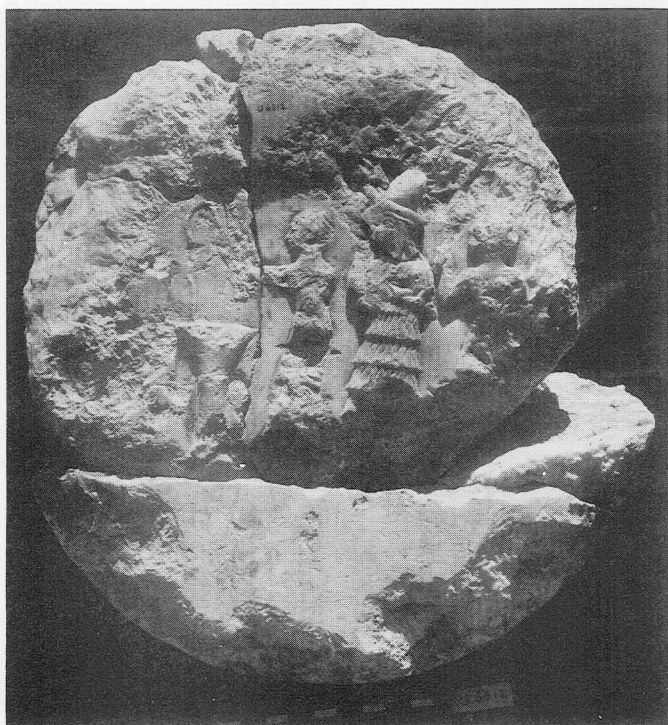

(d) U.6612. Disk of Sargon's Daughter; v. p. 49 and *Ur Texts*, Vol. I, No. 23.

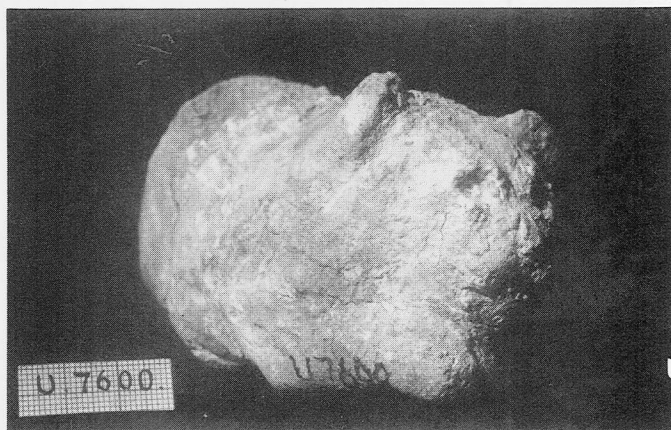

(e) U.7600

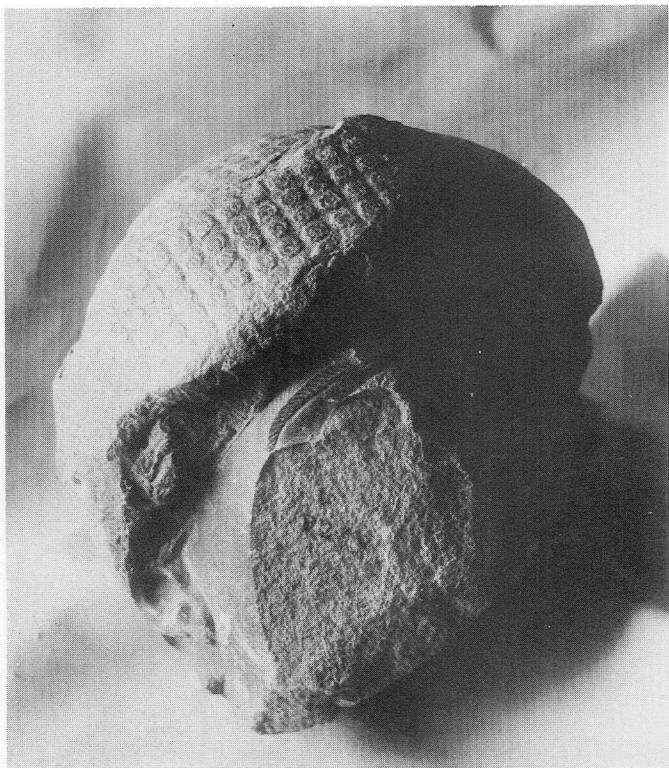

U. 18299

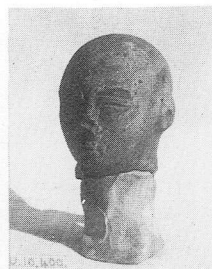

U. 10400

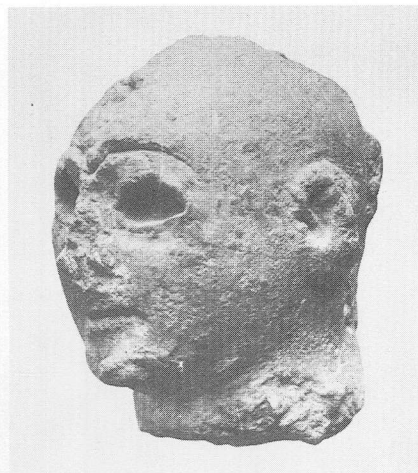

U. 6417

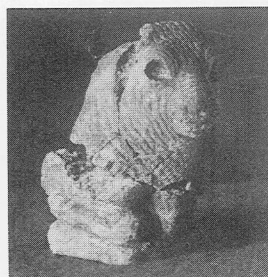

U. 237

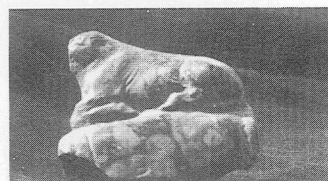

U. 7560



U. 94

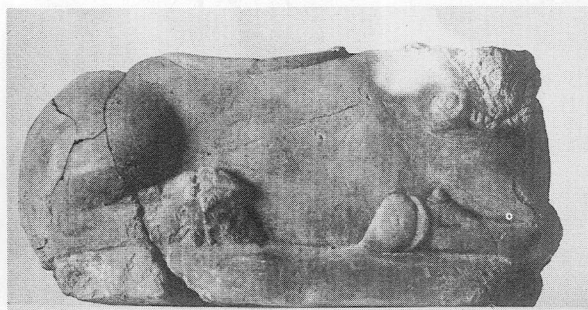

U. 178

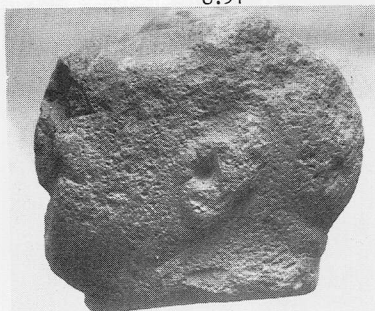

U. 6578

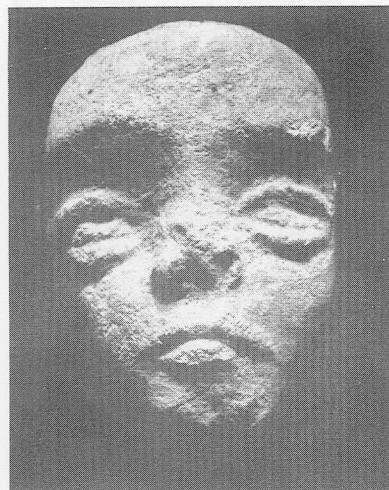

U. 7144

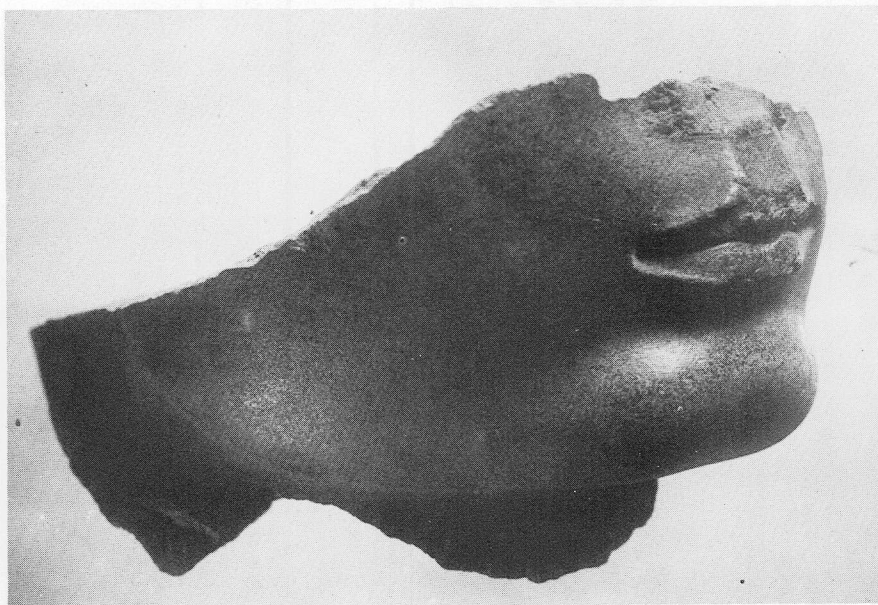

U. 1658; v. p. 51.



114198  
H  
1919  
10/11  
2  
UR



U.6444 Diorite head; v. p. 52.

$\frac{9}{10}$



U.6782 Alabaster head; v. p. 52.

$\frac{9}{10}$

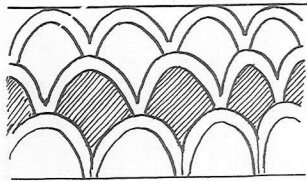

U.18260

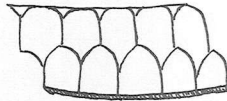

U.17754



U.3208



U.2531

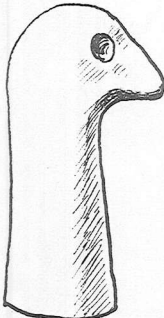

U.19874



U.14446

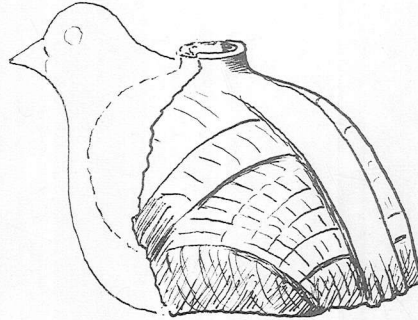

U.14958  $\frac{1}{2}$



U.3225

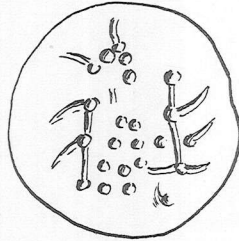

U.16408

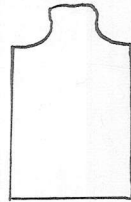

U.11960

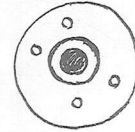

U.14930

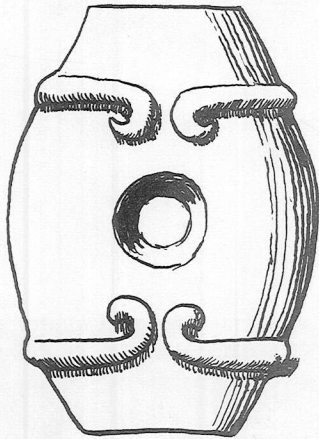

U.11954



U.14476



U.17693

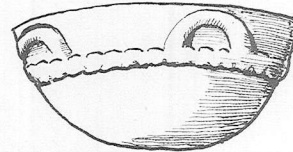

U.13717

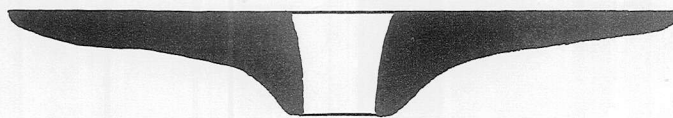

U.18223

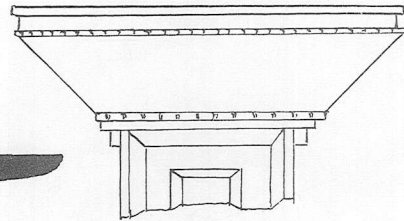

U.18369  $\frac{2}{5}$

Scale  $\frac{4}{5}$  unless otherwise stated

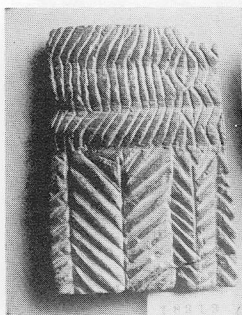

U.18313

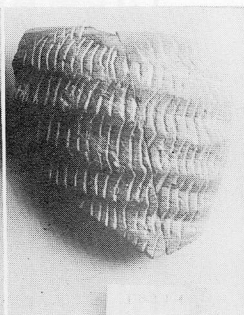

U.18314

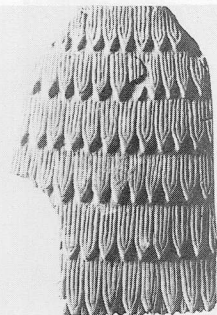

U.3278

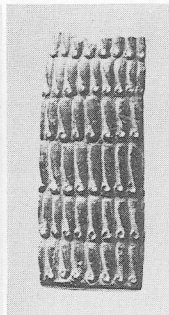

U.6056

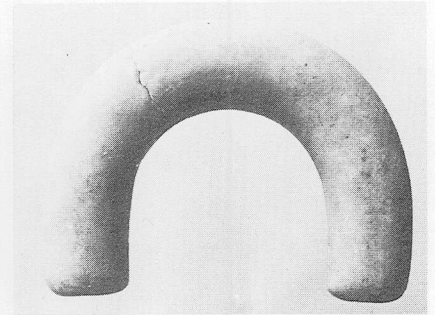

U.6463  
V. p. 45 note 8  
and p. 78.

Steatite Inlay for Composite Statues

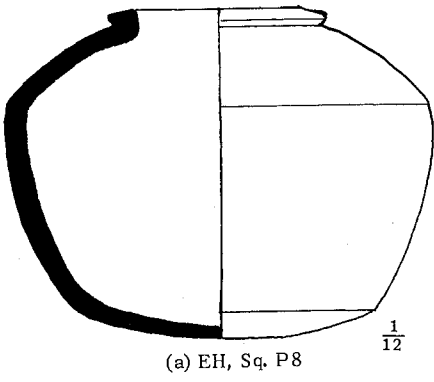

(a) EH, Sq. P8

$\frac{1}{12}$

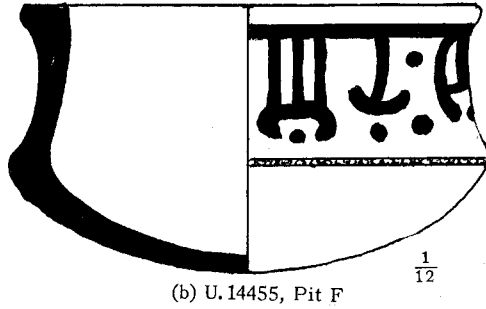

(b) U. 14455, Pit F

$\frac{1}{12}$

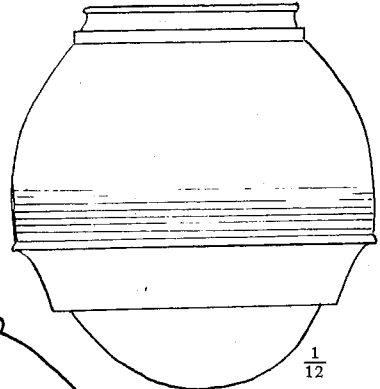

(c) EH, Sq. P8

$\frac{1}{12}$

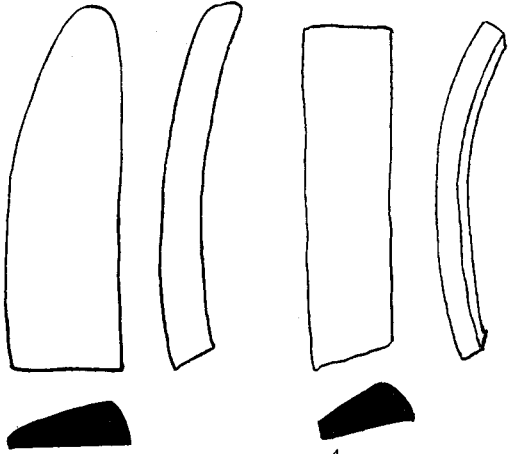

(e) U. 14927 A, B

$\frac{4}{5}$

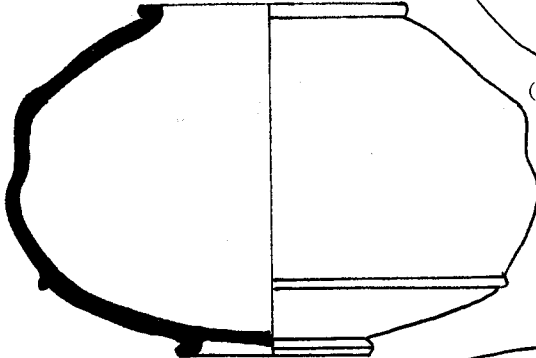

(d) U. 13736, Pit F

$\frac{1}{12}$

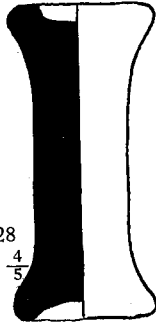

(f) U. 15328

$\frac{4}{5}$

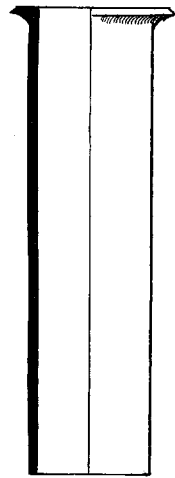

(i) U. 14488  
Pit F

$\frac{1}{12}$

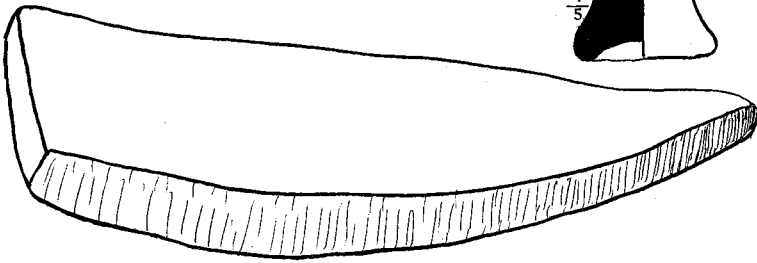

(g) U. 14939

$\frac{4}{5}$

(h) U. 14938  
Pit G

$\frac{4}{5}$

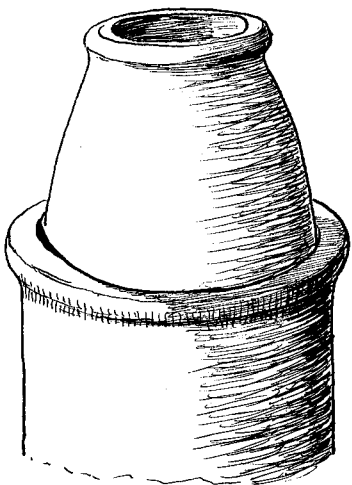

(j) Pit F, Sq. C5

$\frac{1}{12}$

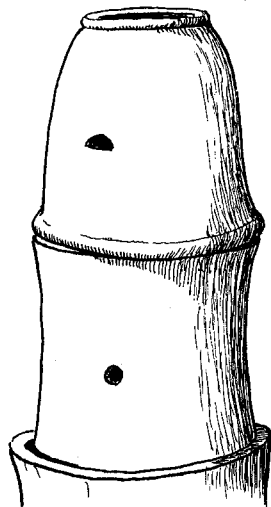

(k) EH, Sq. N6

$\frac{1}{12}$

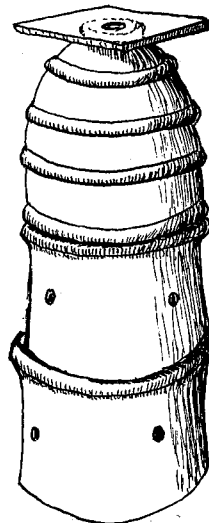

(l) EH, Sq. N8

$\frac{1}{12}$

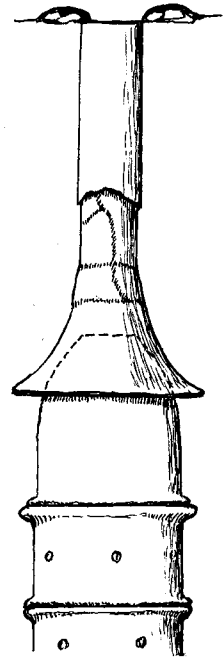

(m) EH, Sq. N7

$\frac{1}{12}$

TERRA-COTTA STORE-JARS, TOOLS AND DRAINS

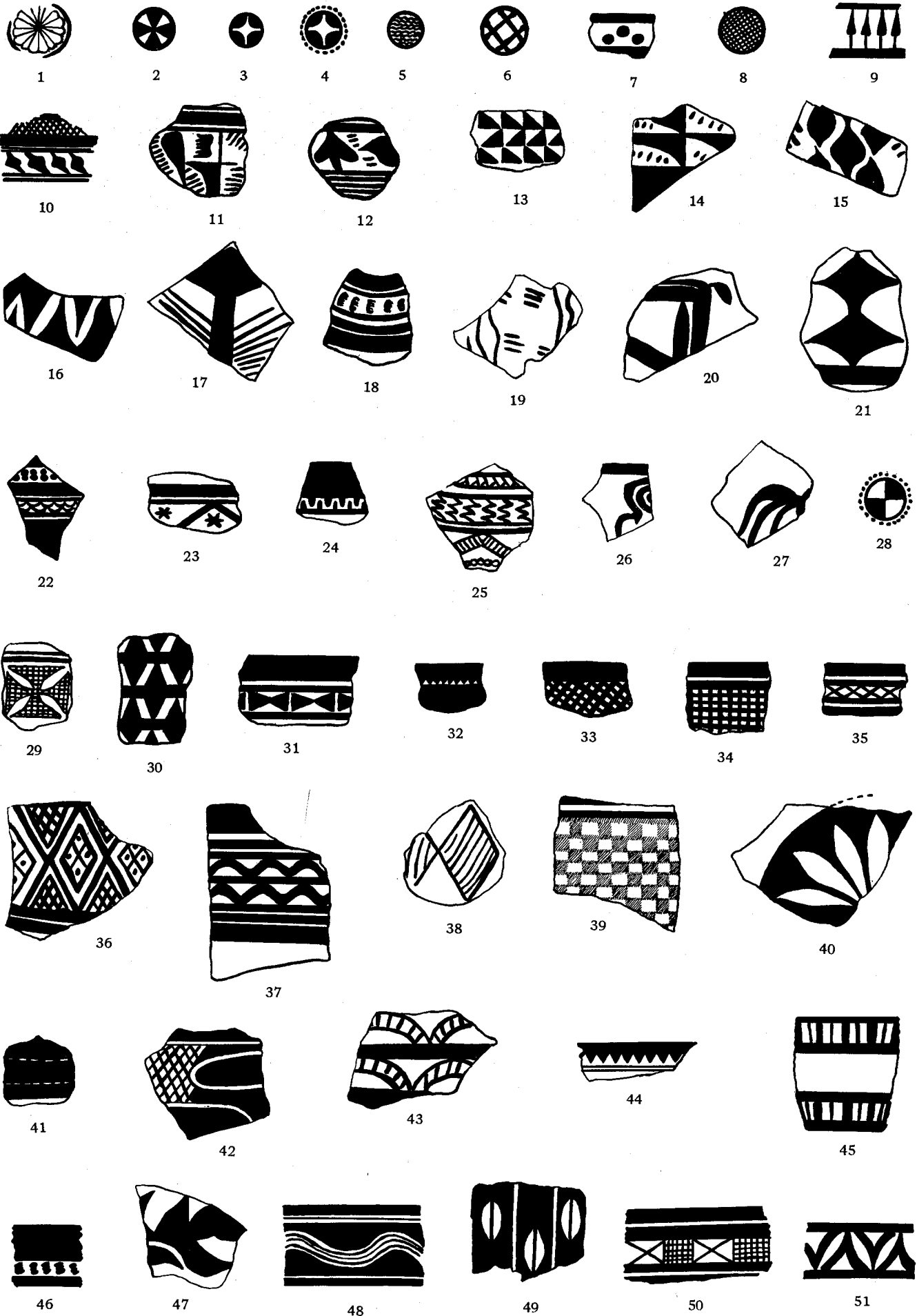

PIT K. PAINTED POTTERY FRAGMENTS OF THE PERIOD AL 'UBAID I; v. pp. 8, 72.



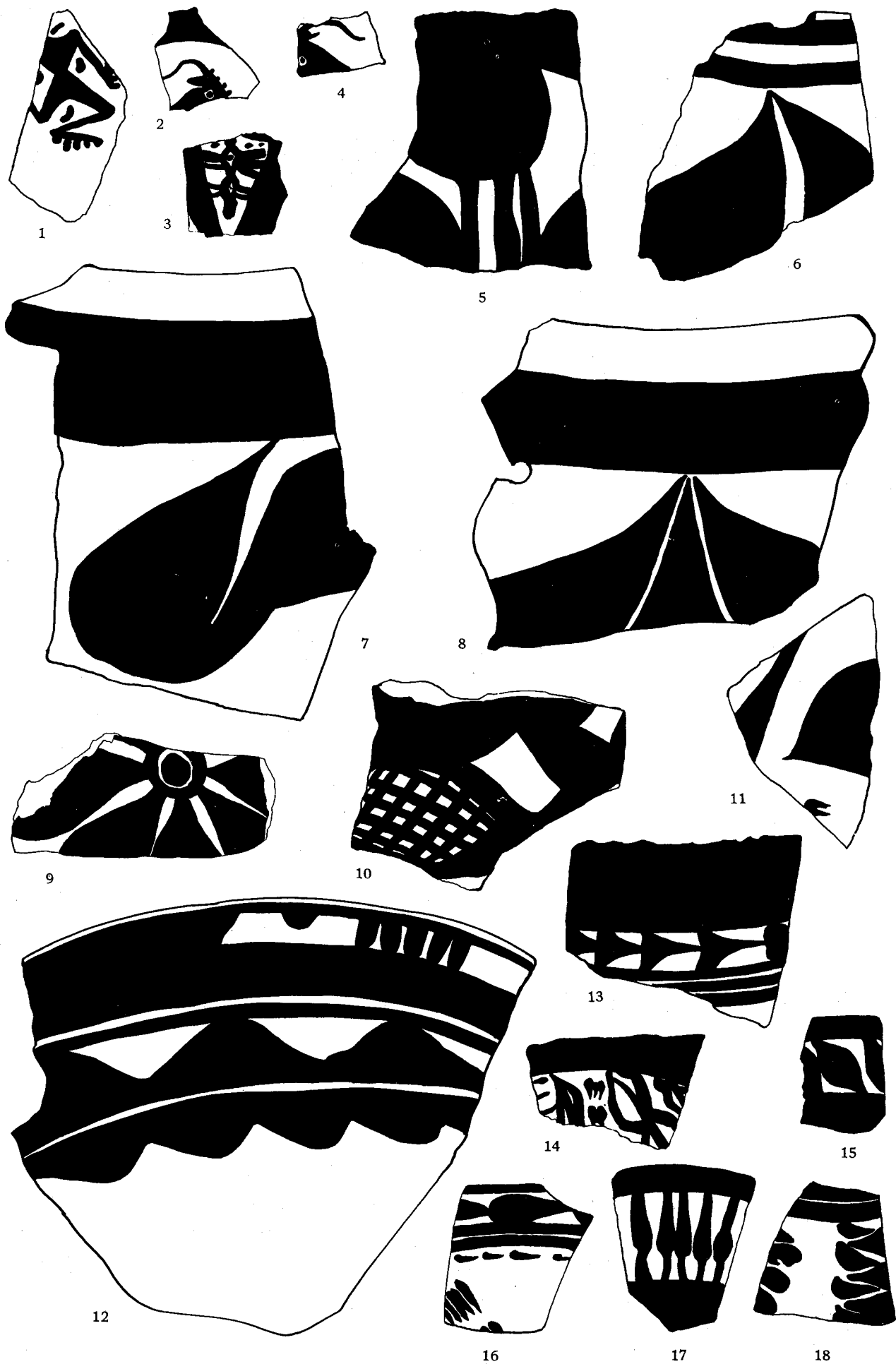

PIT K. PAINTED POTTERY FRAGMENTS OF THE PERIOD AL 'UBAID I; *v.* pp. 8, 72.

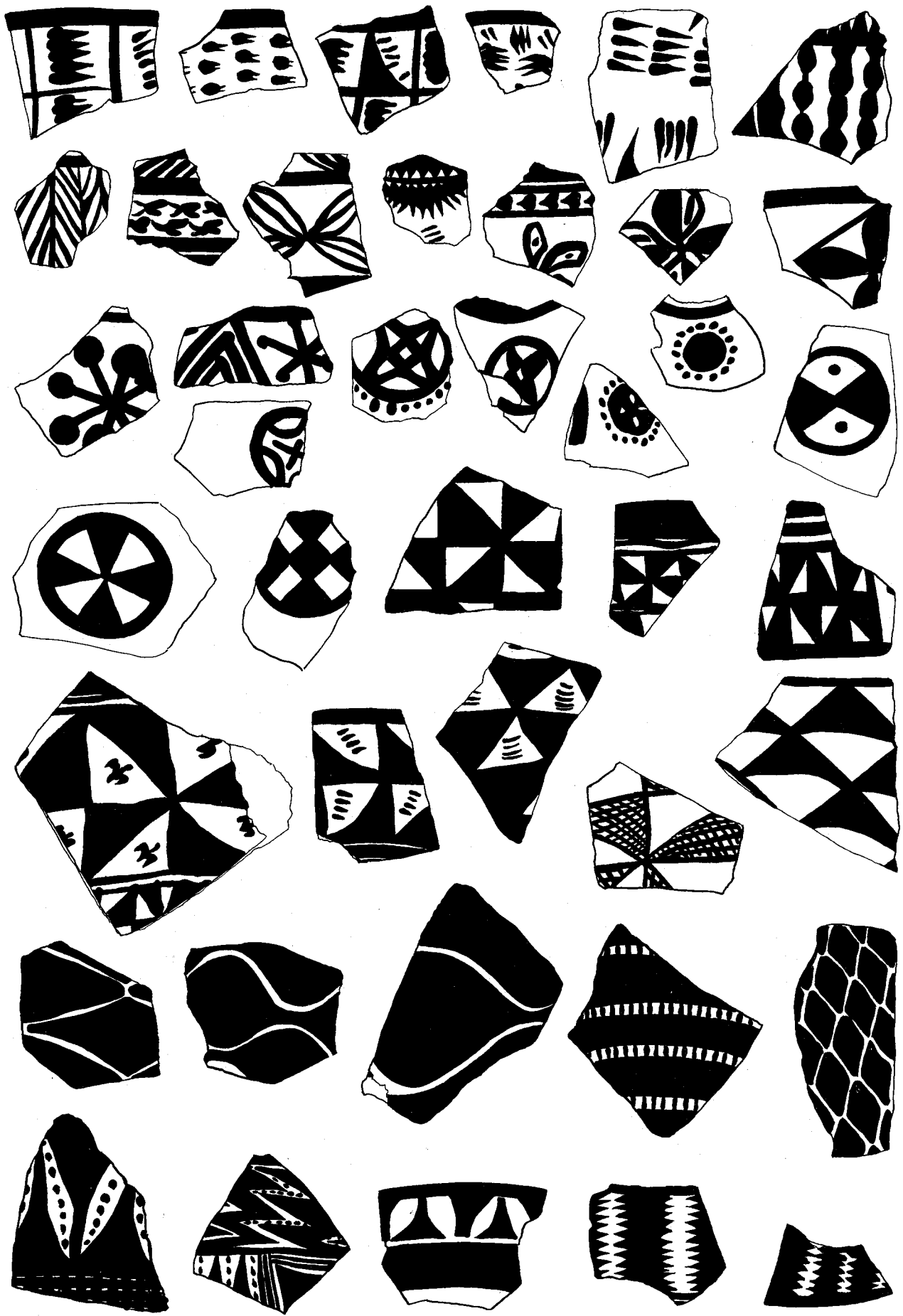

PIT K. PAINTED POTTERY FRAGMENTS OF THE PERIOD AL 'UBAID I; v. pp. 73-74.



PIT K. PAINTED POTTERY FRAGMENTS OF THE PERIOD AL'UBAID I; v. pp. 73-74.



PIT K. PAINTED POTTERY FRAGMENTS OF THE PERIOD AL 'UBAID I; v. pp. 73-74.

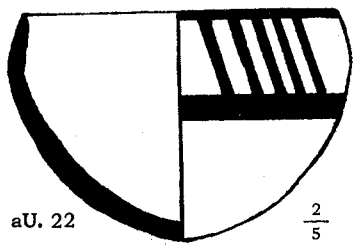
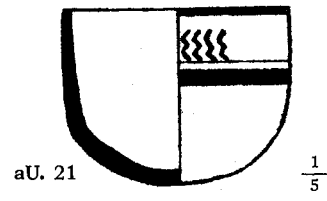
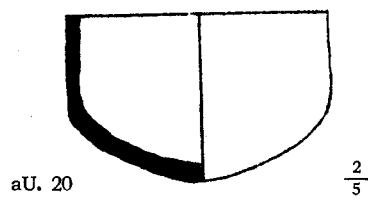
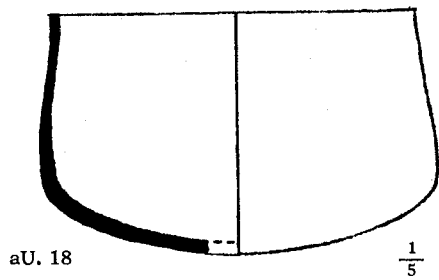
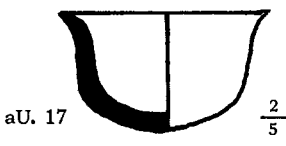
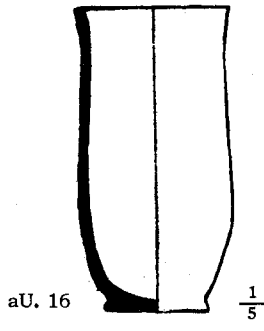
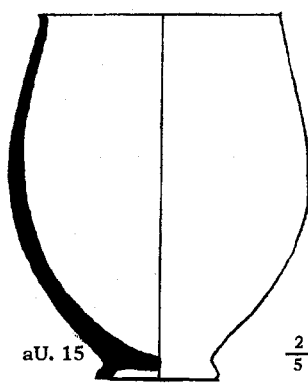
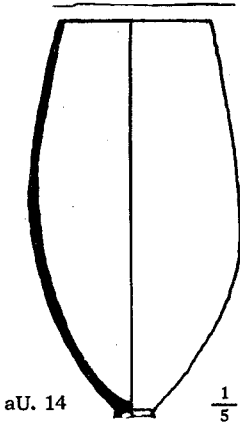
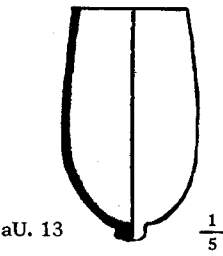
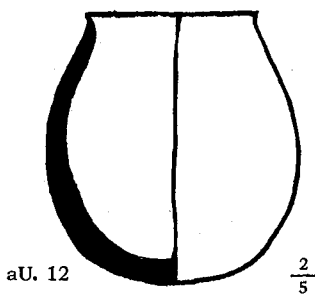
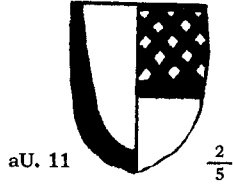
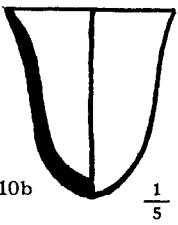
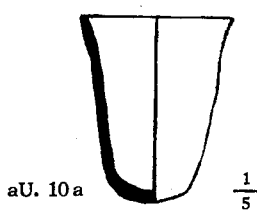
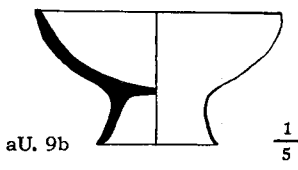
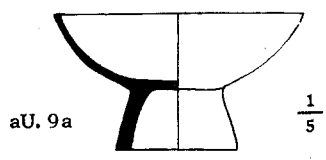
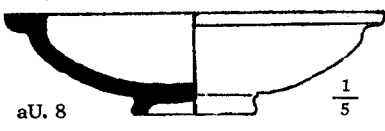
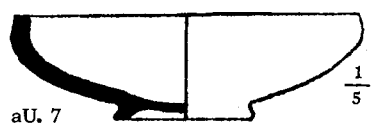
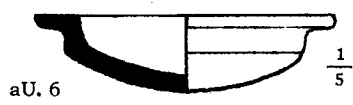
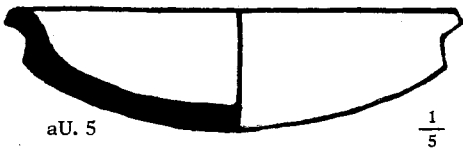
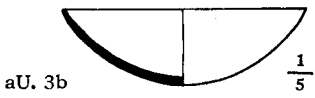
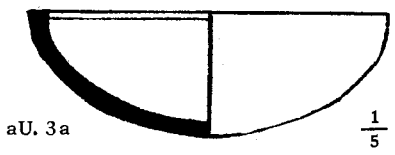
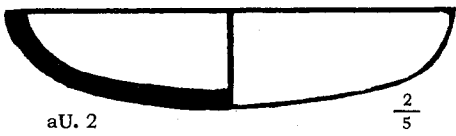
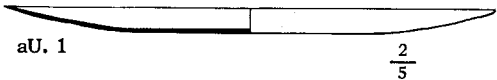

TYPES OF AL 'UBAID POTTERY

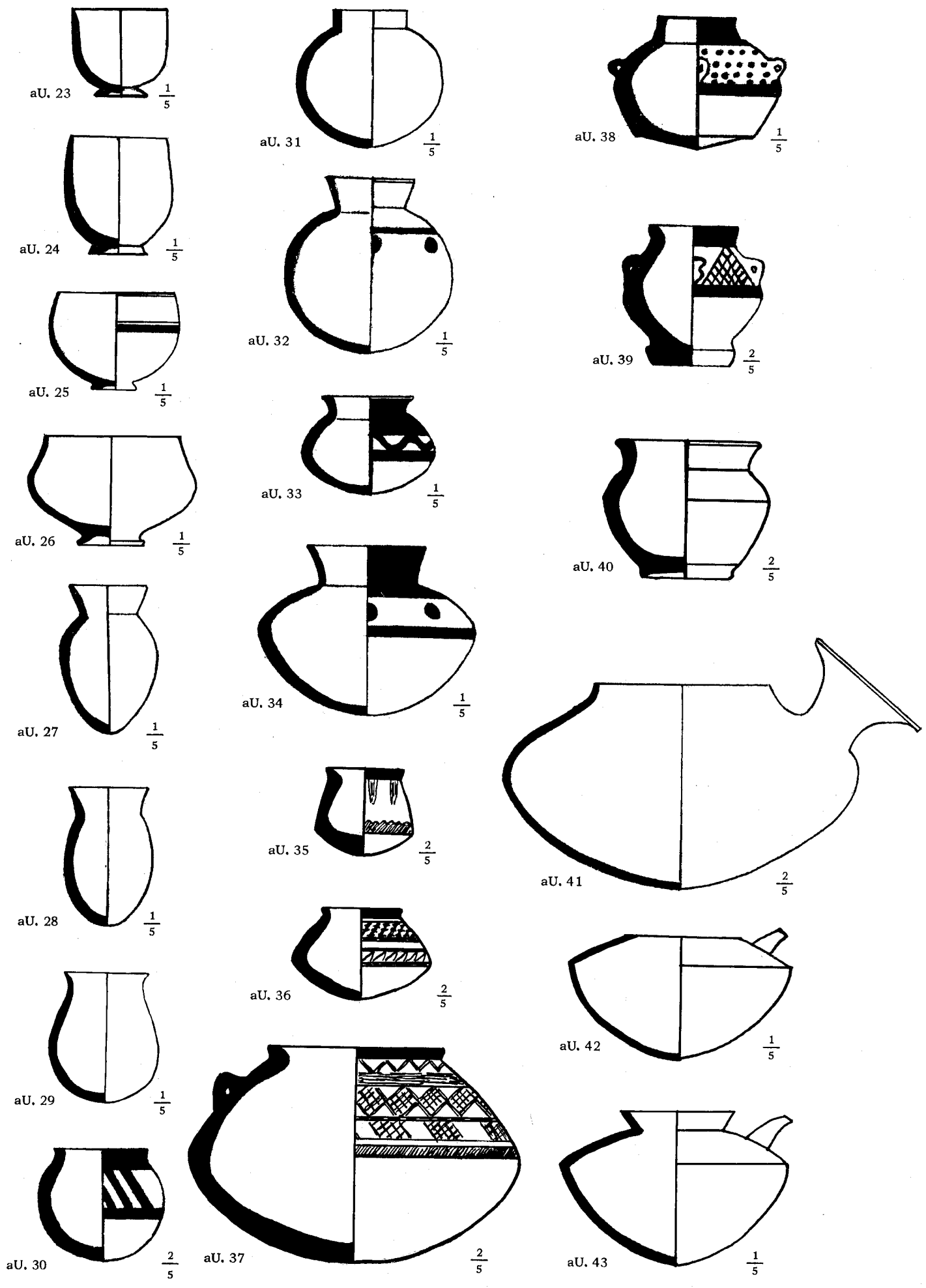

TYPES OF AL'UBAID POTTERY

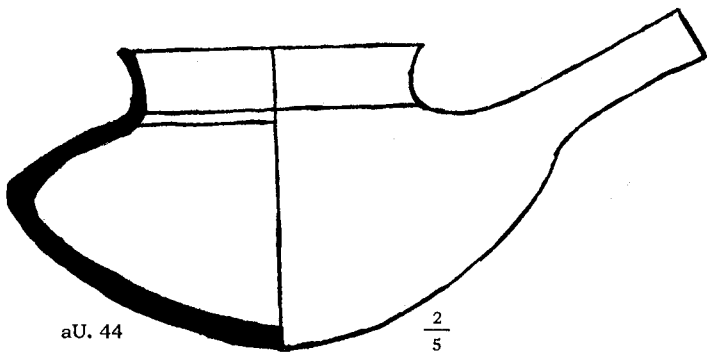

aU. 44

$\frac{2}{5}$

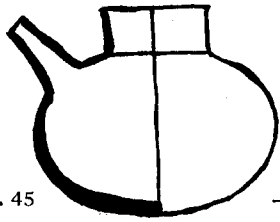

aU. 45

$\frac{1}{5}$

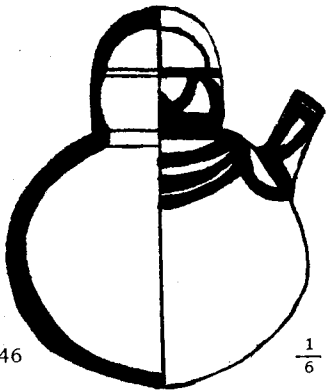

aU. 46

$\frac{1}{6}$

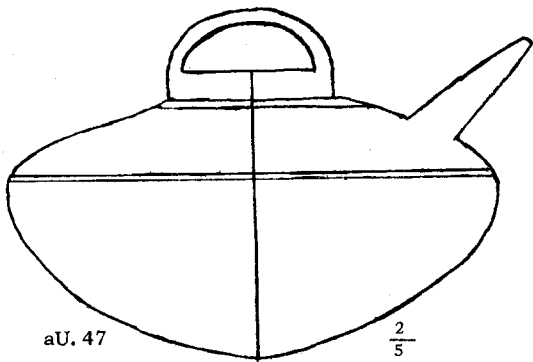

aU. 47

$\frac{2}{5}$

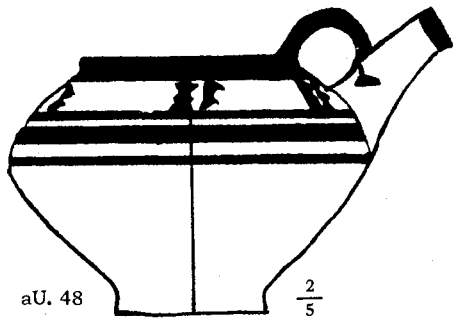

aU. 48

$\frac{2}{5}$



aU. 49

$\frac{1}{5}$

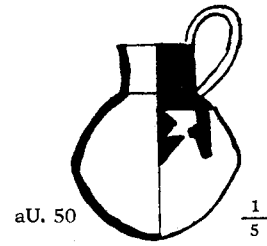

aU. 50

$\frac{1}{5}$

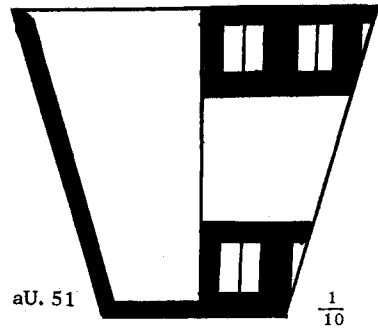

aU. 51

$\frac{1}{10}$

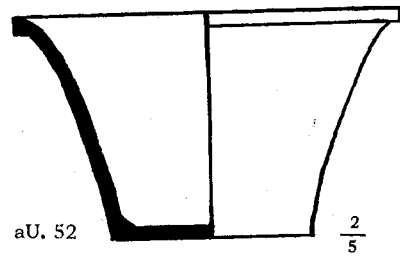

aU. 52

$\frac{2}{5}$

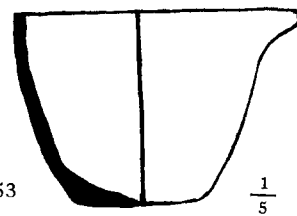

aU. 53

$\frac{1}{5}$

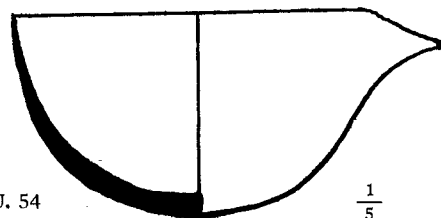

aU. 54

$\frac{1}{5}$

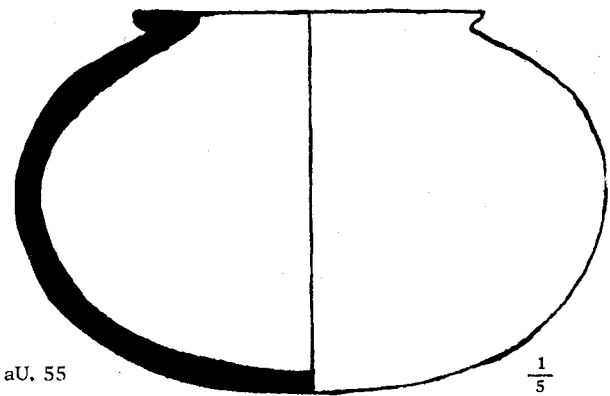

aU. 55

$\frac{1}{5}$

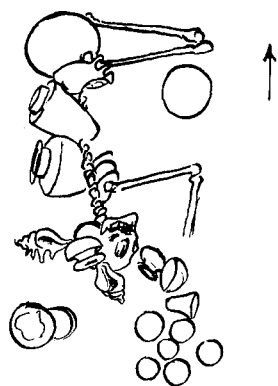

JNG/42

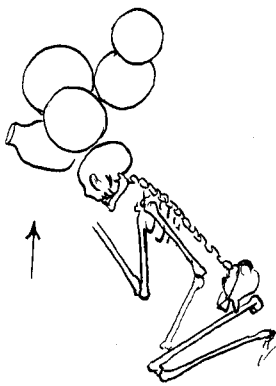

JNG/87

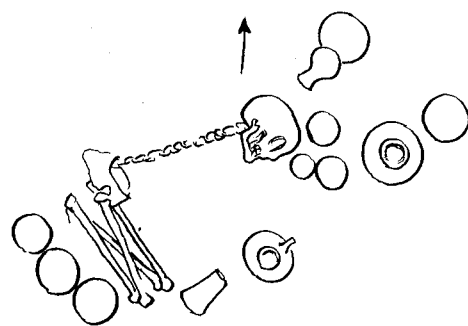

JNG/90

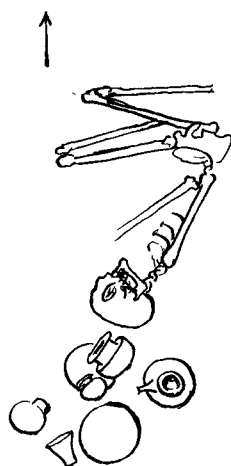

JNG/91

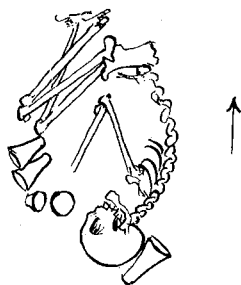

JNG/100

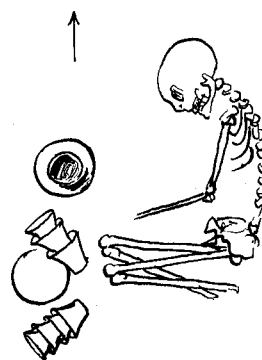

JNG/116

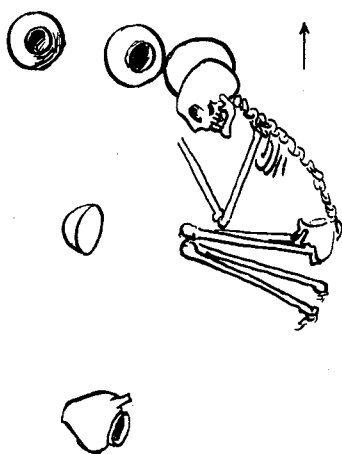

JNG/124

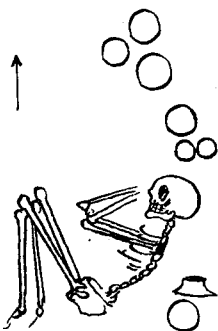

JNG/152

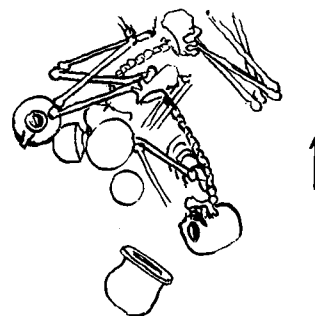

JNG/157



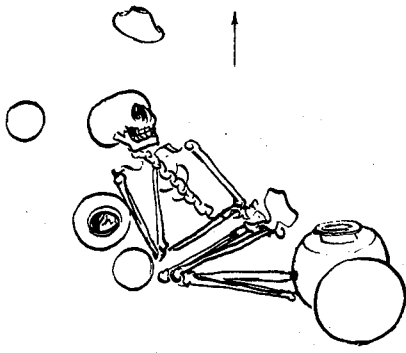

JNG/182

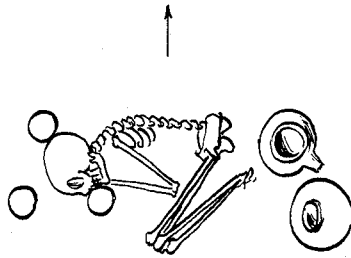

JNG/191

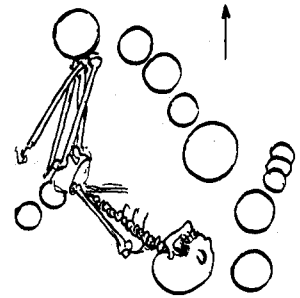

JNG/204

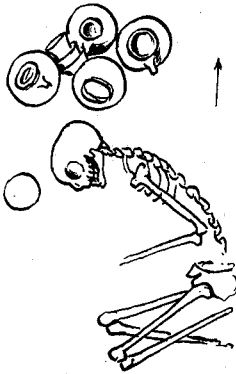

JNG/207

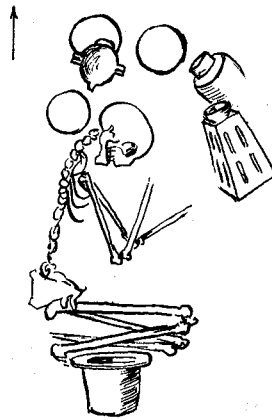

JNG/210

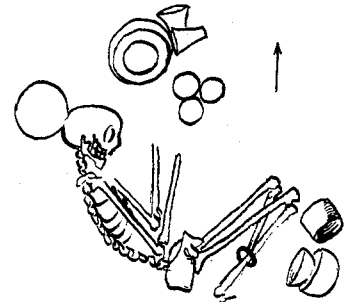

JNG/220

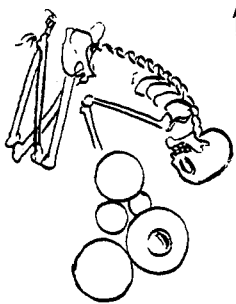

JNG/266

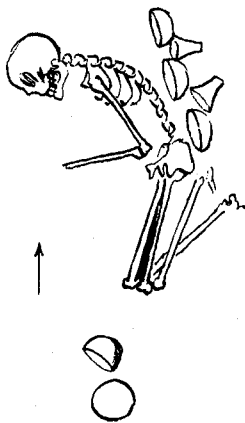

JNG/275

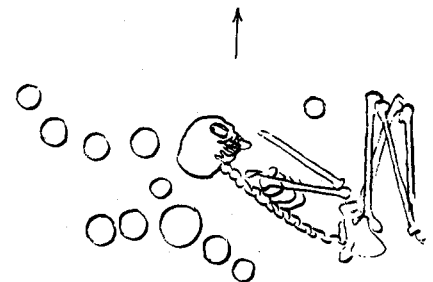

JNG/340

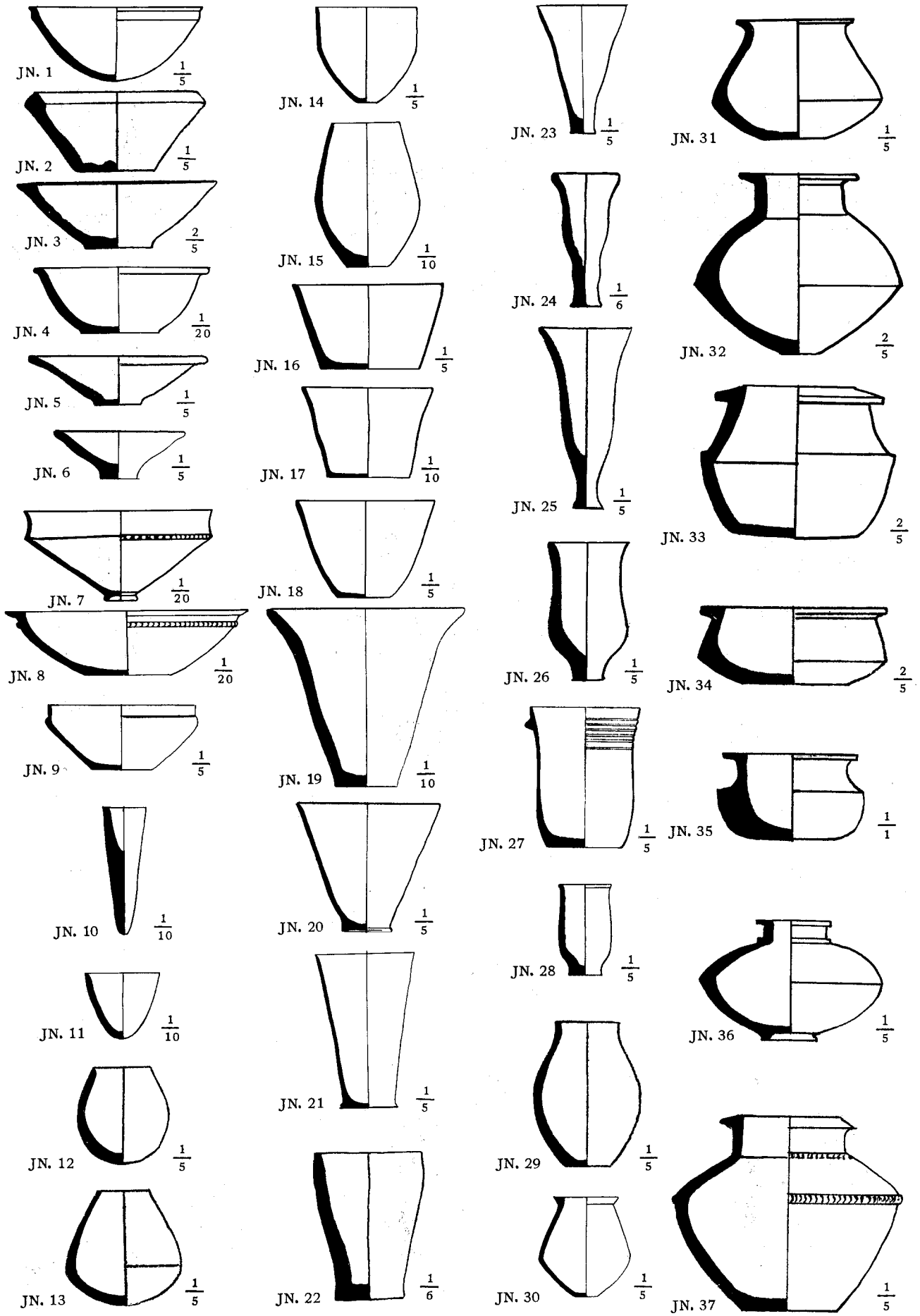

TYPES OF JAMDAT NASR POTTERY

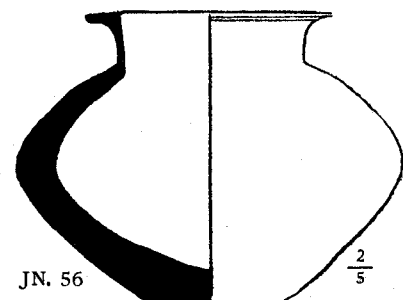
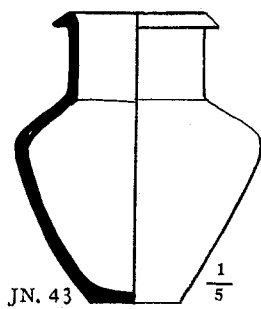
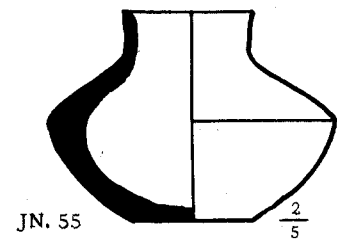
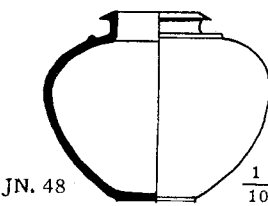
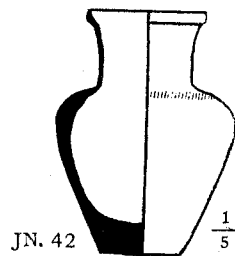
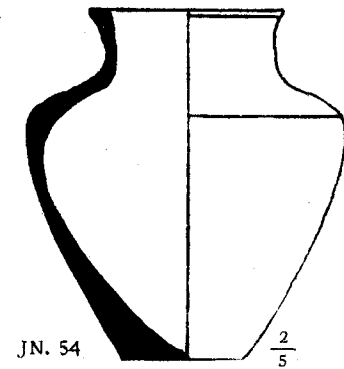
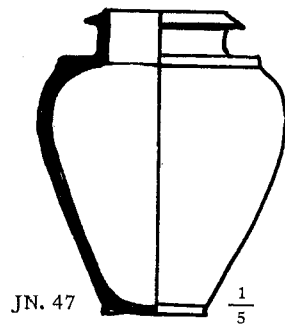
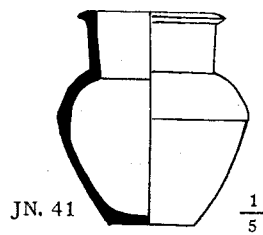
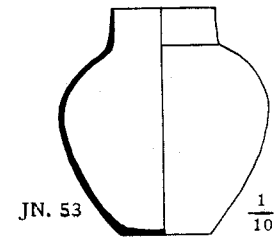
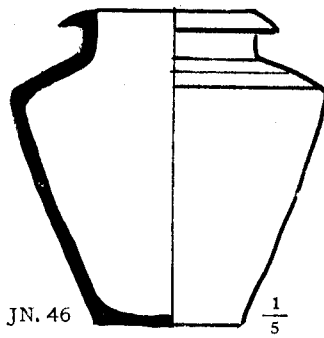
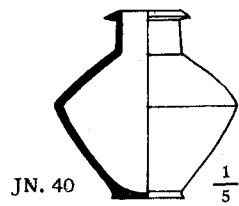
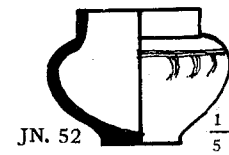
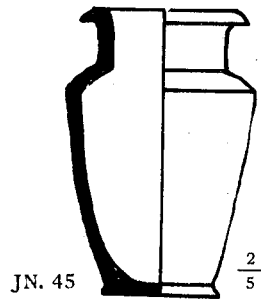
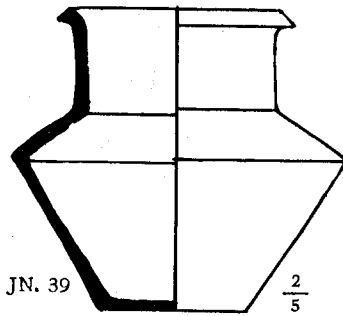
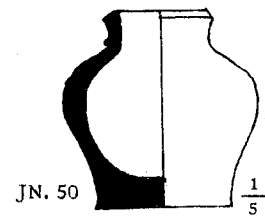
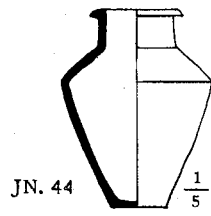
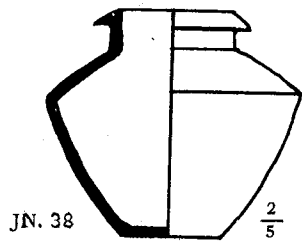

TYPES OF JAMDAT NASR POTTERY

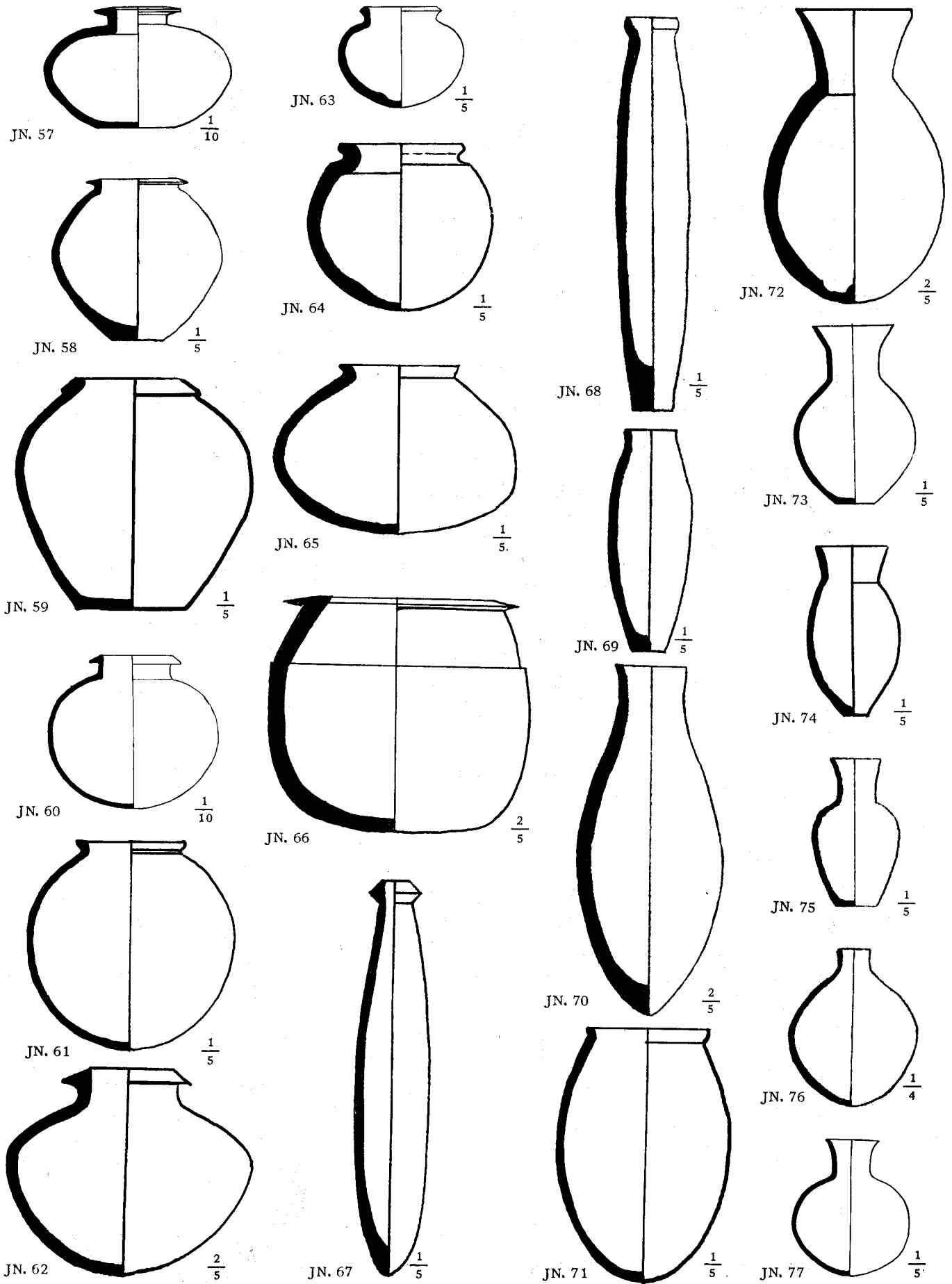

TYPES OF JAMDAT NASR POTTERY

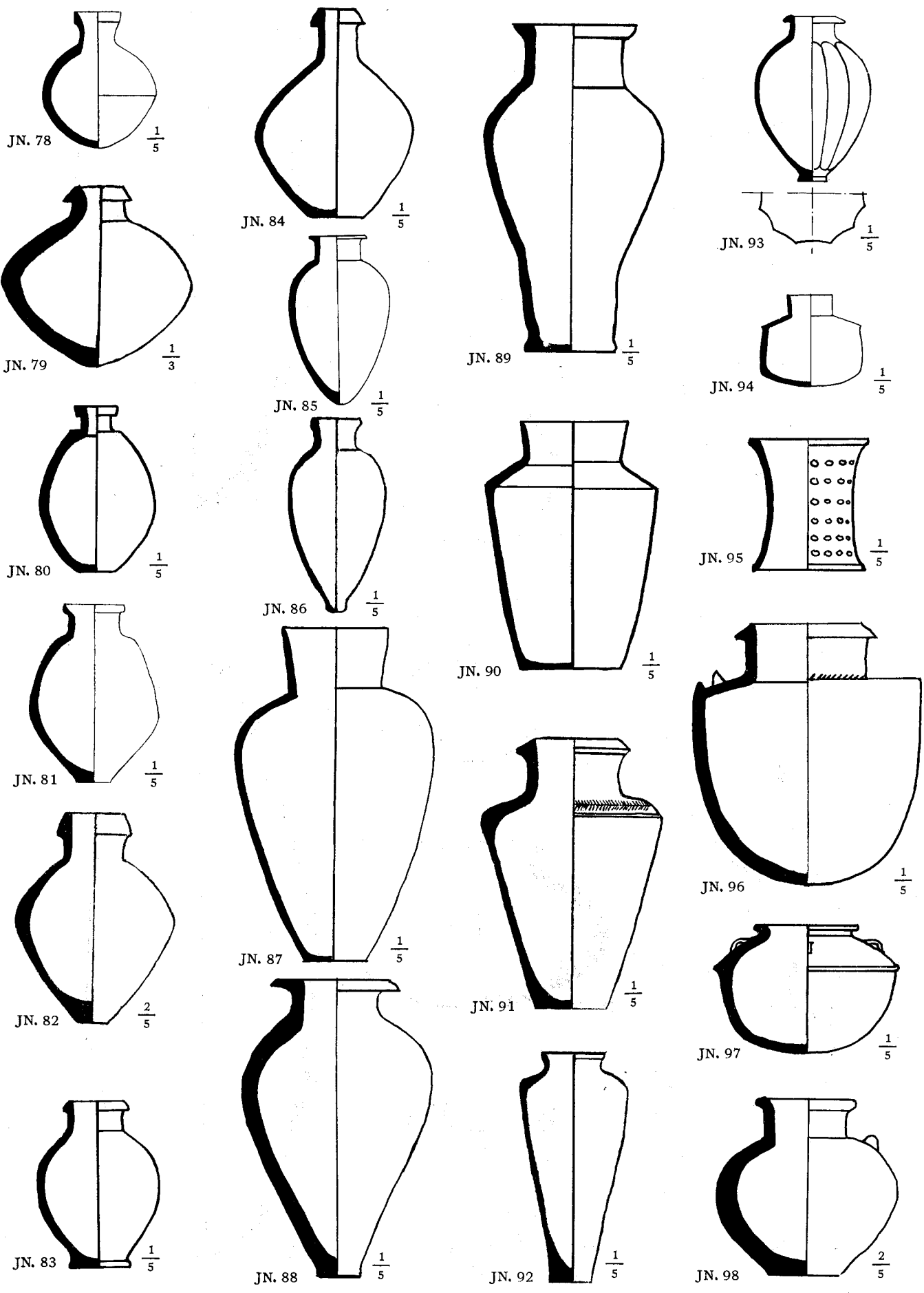

TYPES OF JAMDAT NASR POTTERY

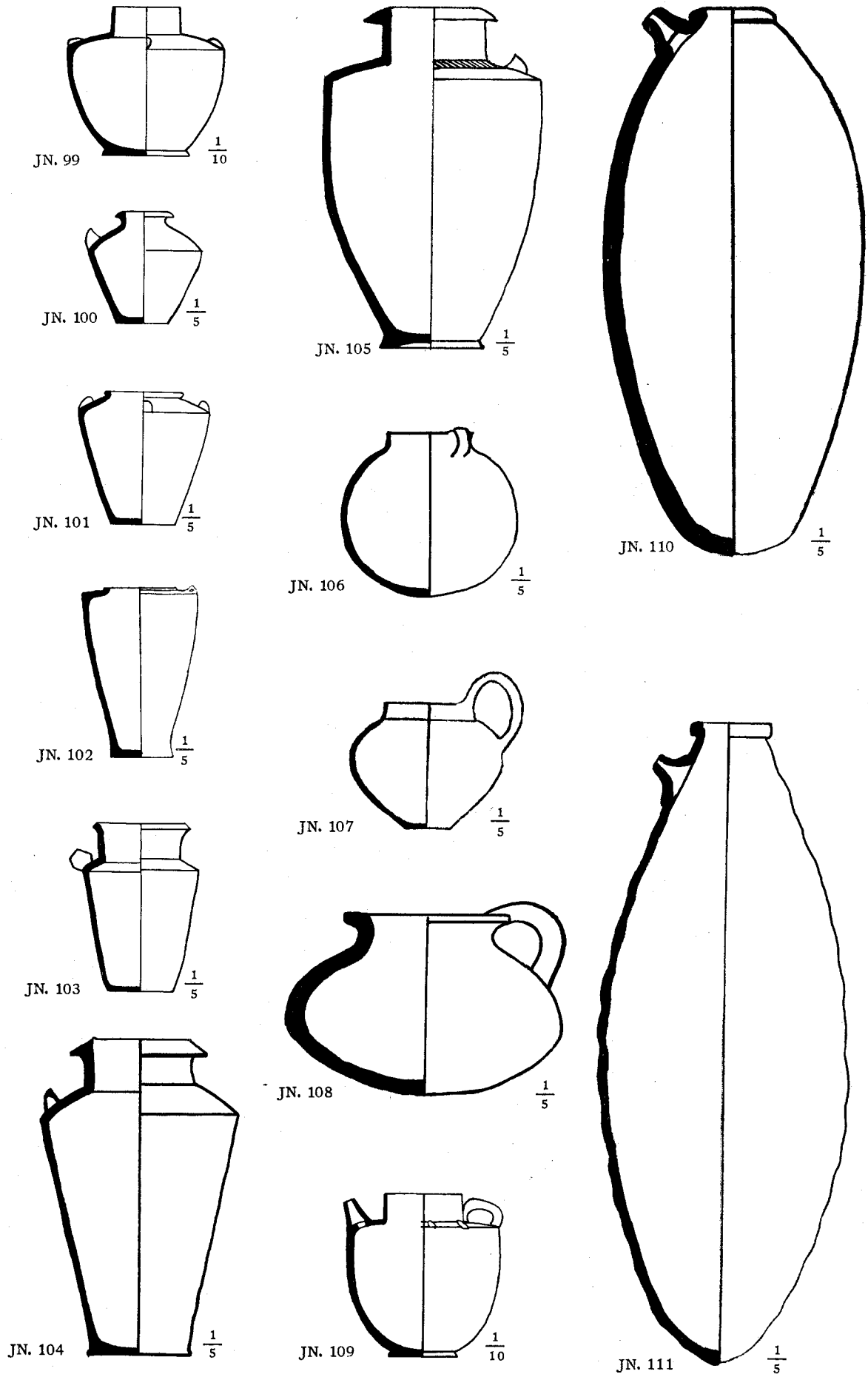

TYPES OF JAMDAT NASR POTTERY

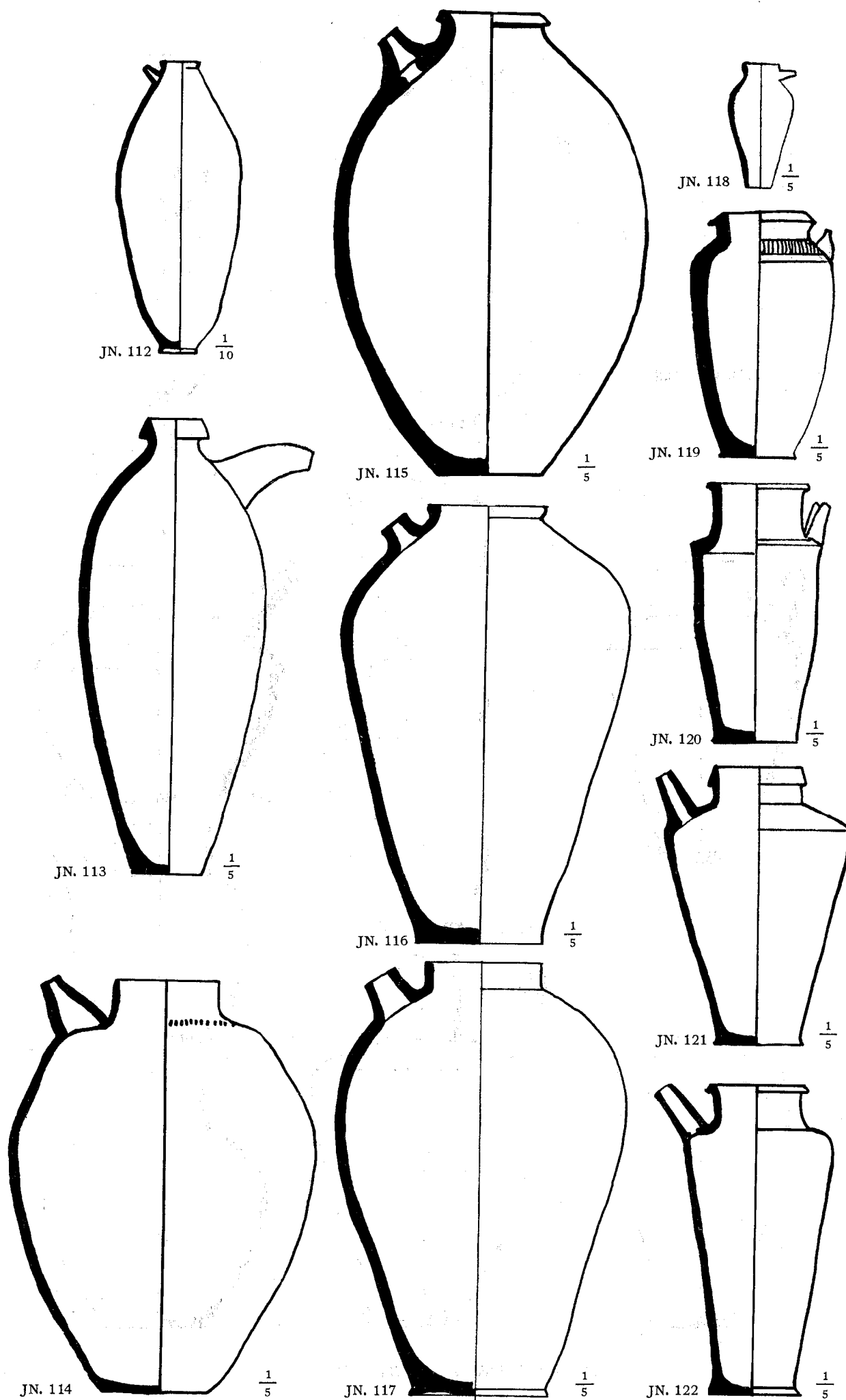

TYPES OF JAMDAT NASR POTTERY

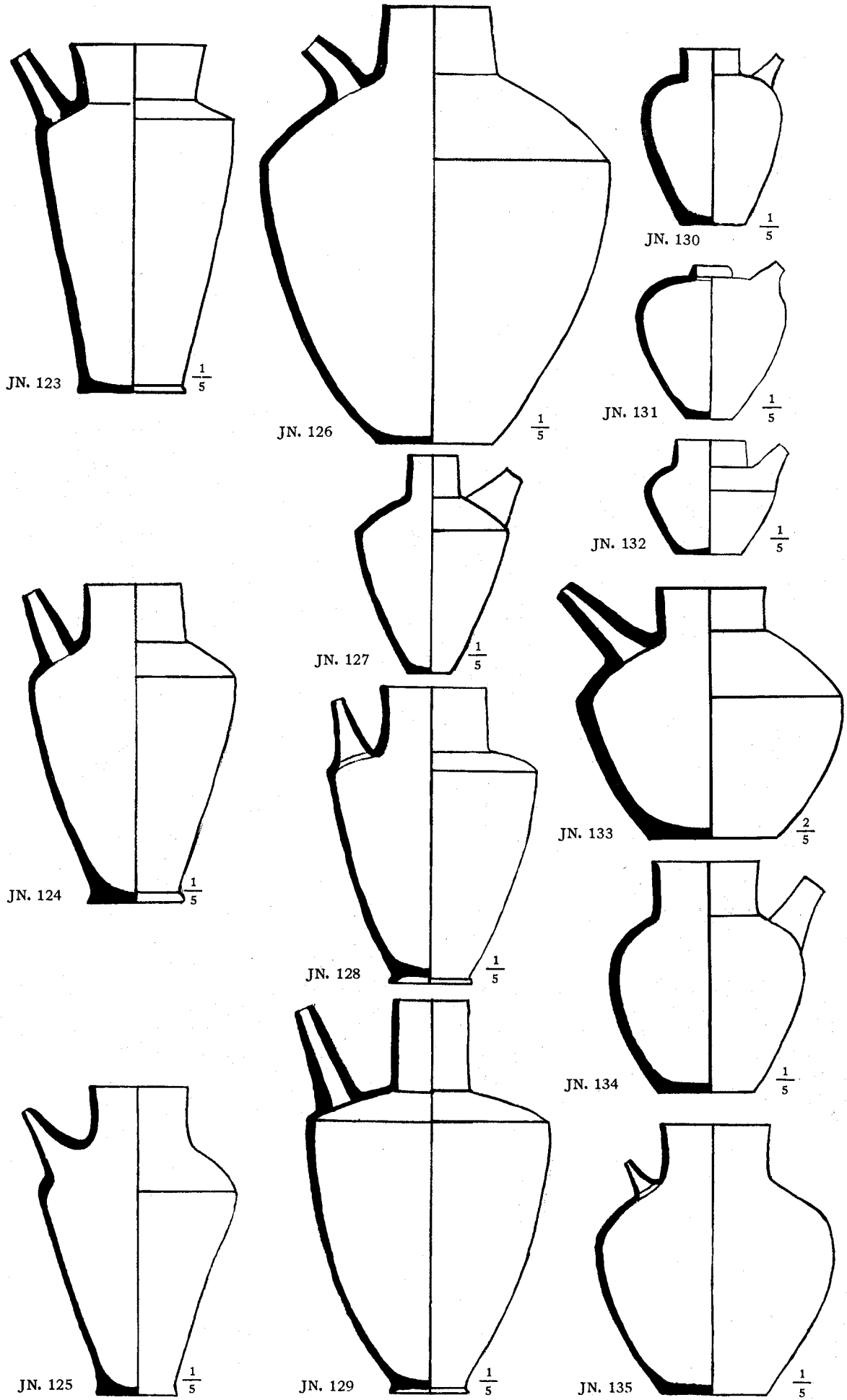

TYPES OF JAMDAT NASR POTTERY



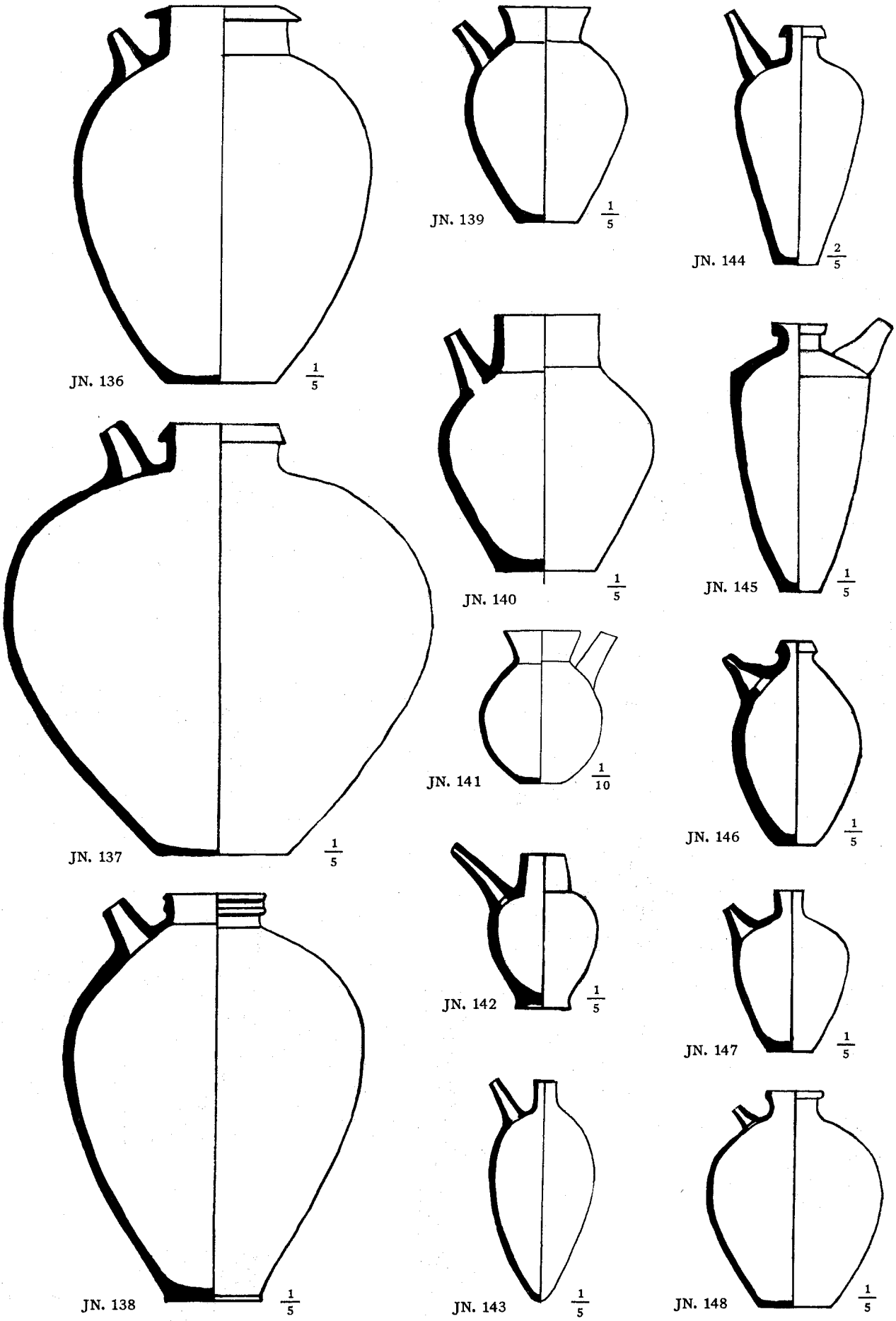

TYPES OF JAMDAT NASR POTTERY

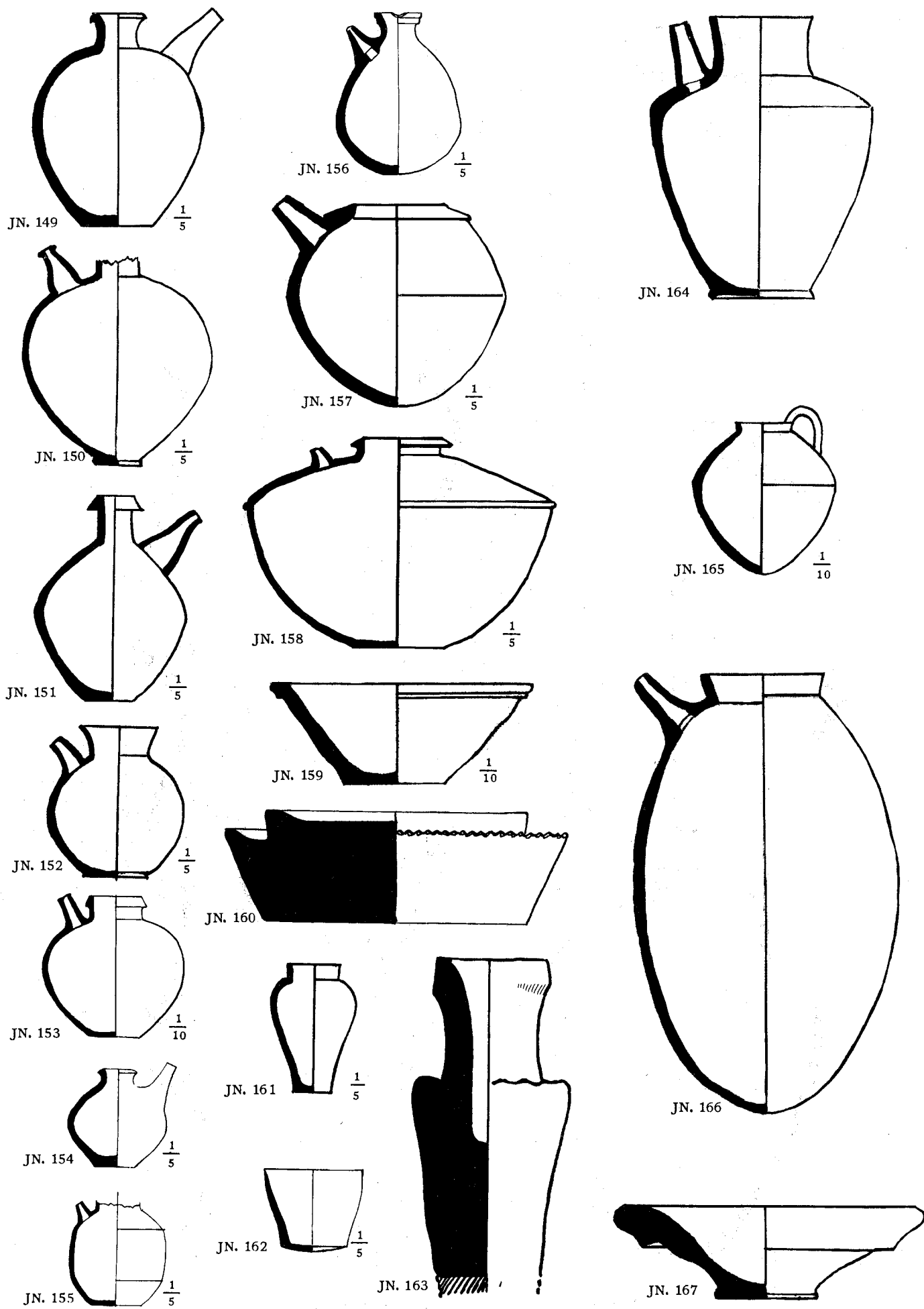

TYPES OF JAMDAT NASR POTTERY

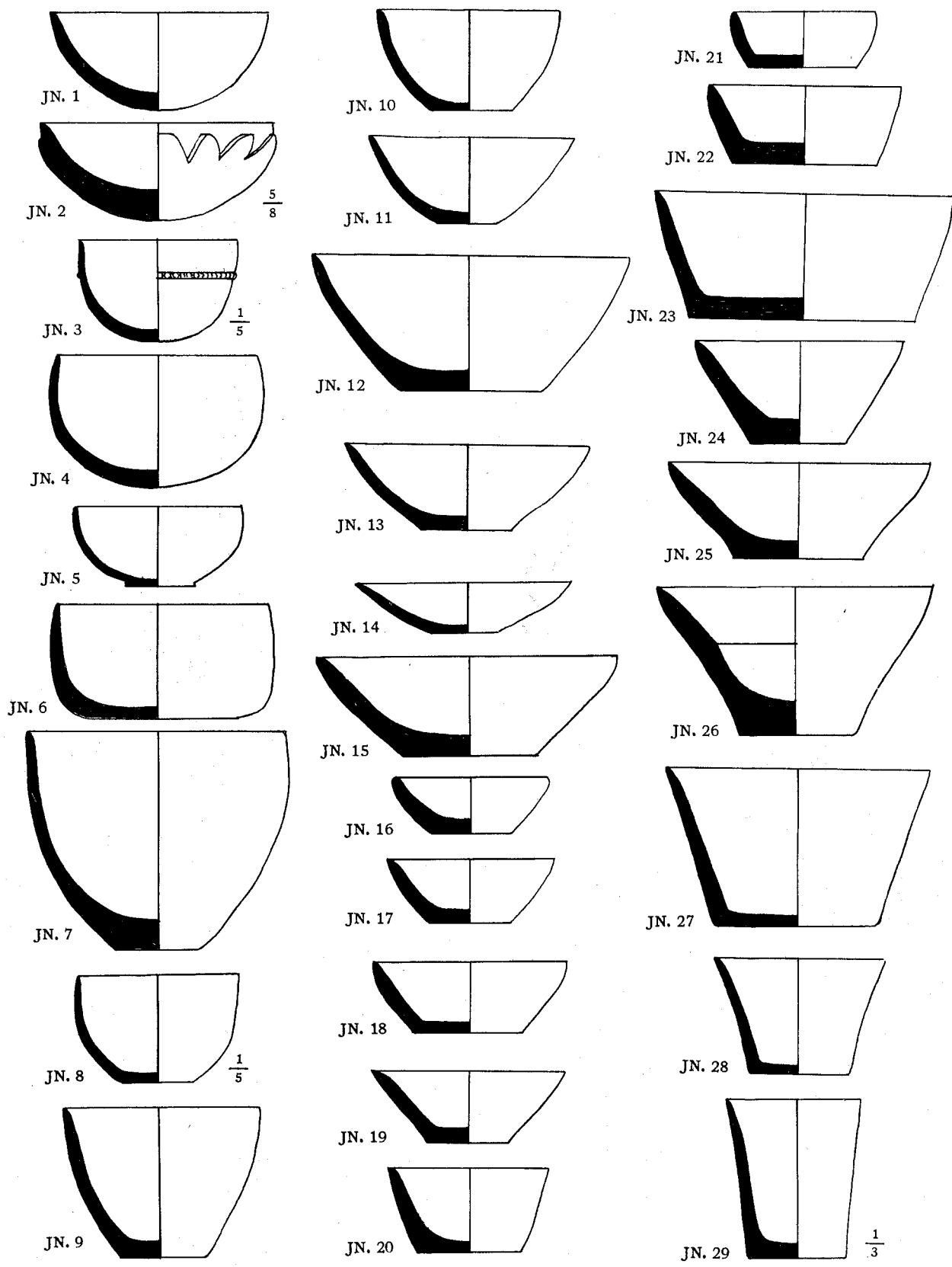

TYPES OF JAMDAT NASR STONE VASES

Scale  $\frac{1}{4}$  unless otherwise stated

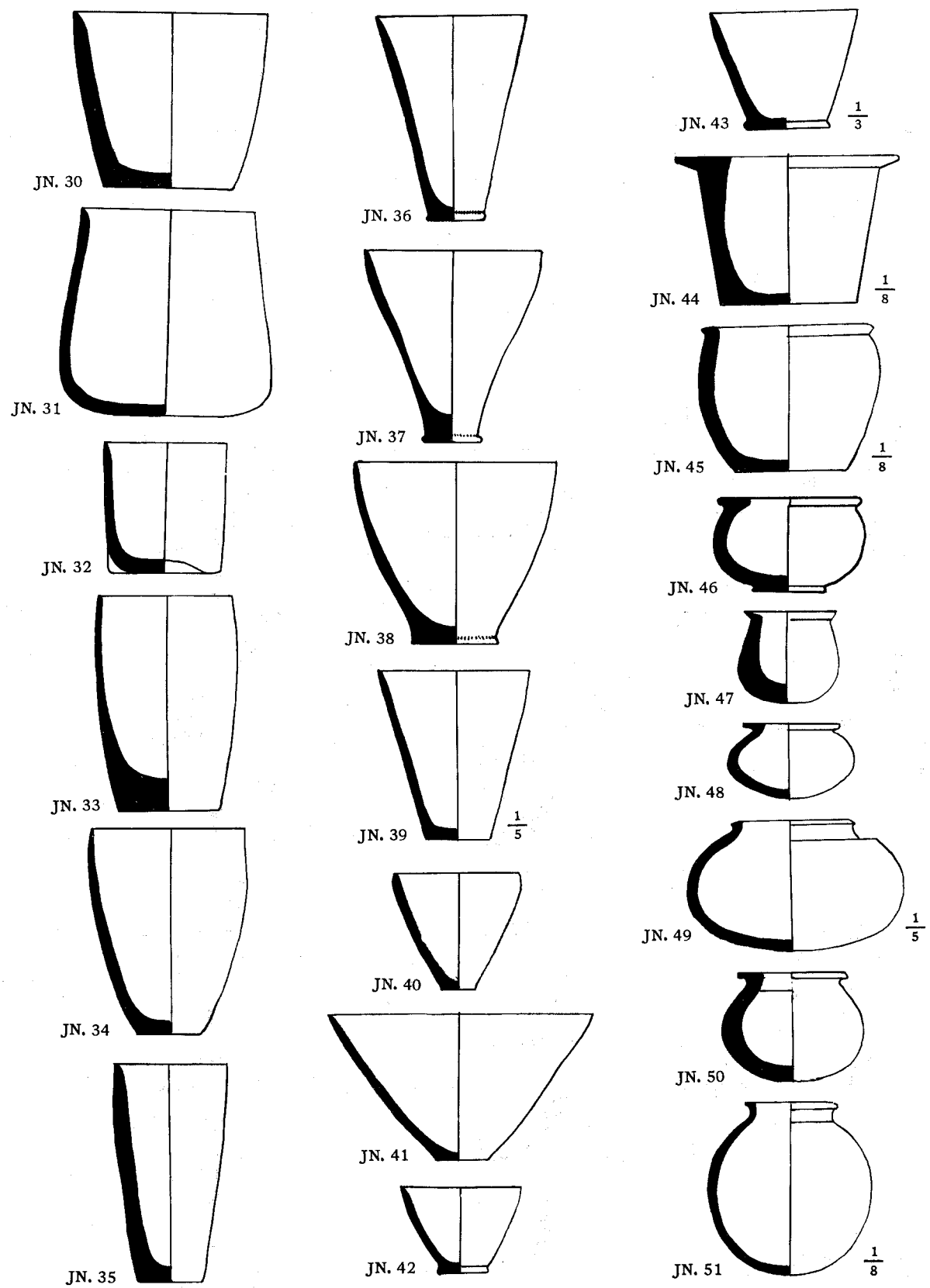

TYPES OF JAMDAT NASR STONE VASES

Scale  $\frac{1}{4}$  unless otherwise stated

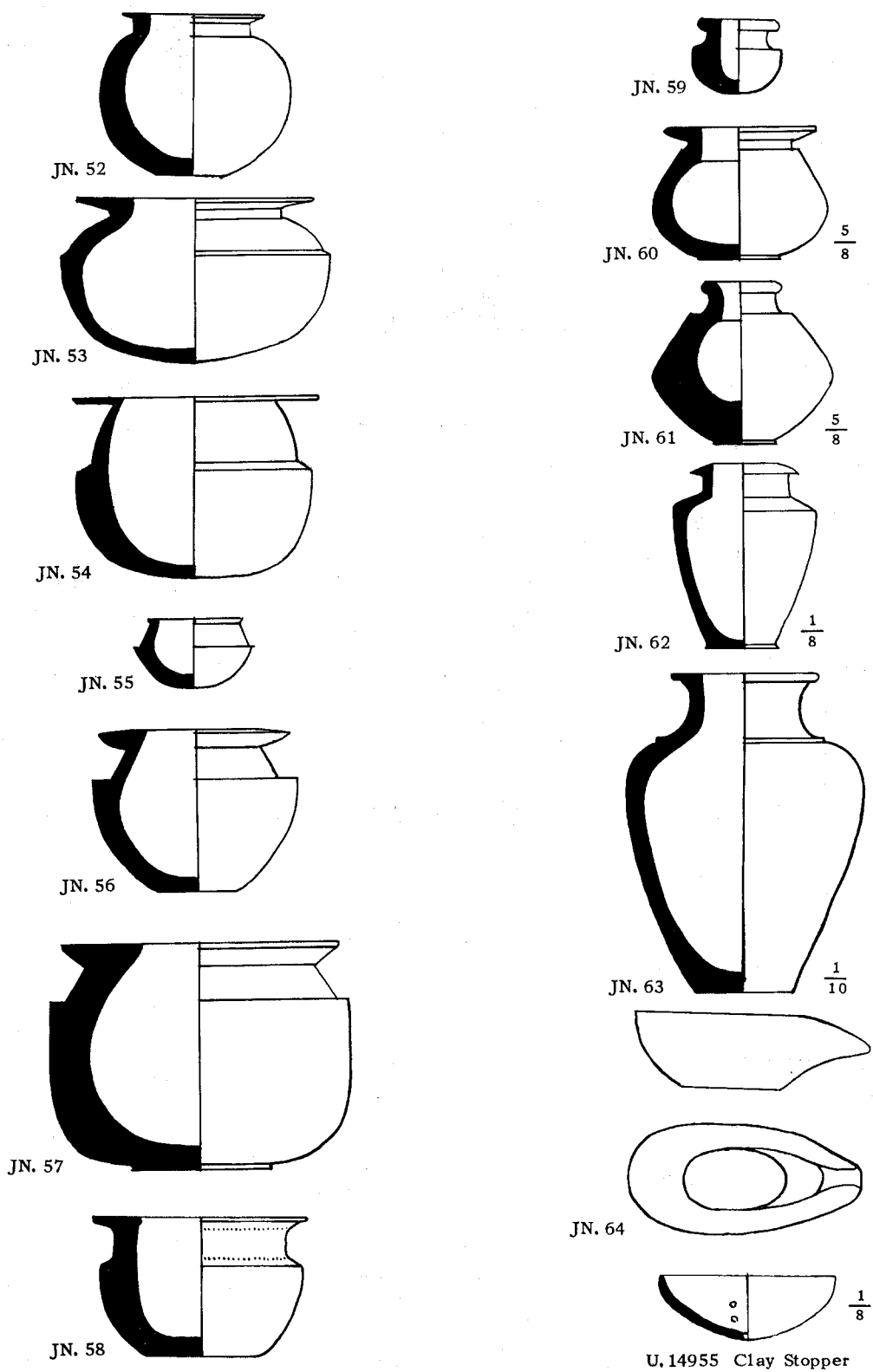

TYPES OF JAMDAT NASR STONE VASES

Scale  $\frac{1}{4}$  unless otherwise stated

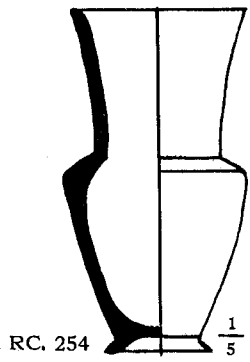

RC. 254

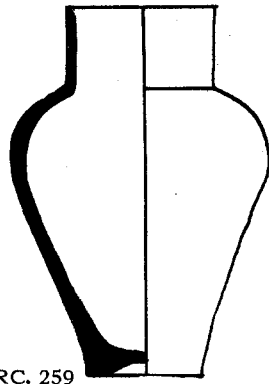

RC. 259

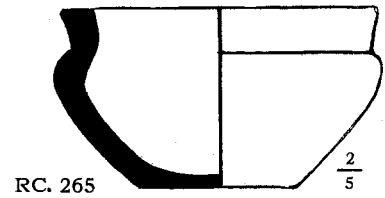

RC. 265

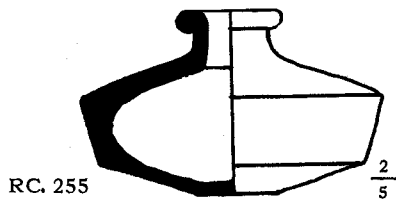

RC. 255

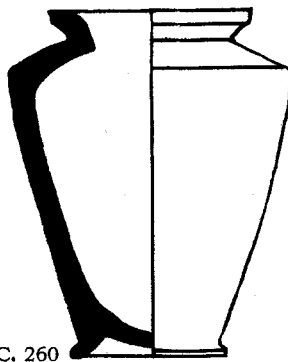

RC. 260

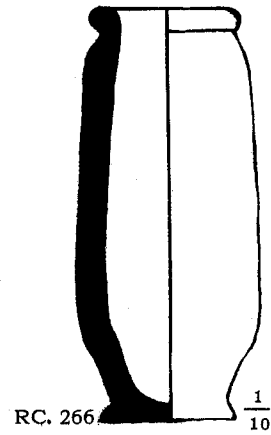

RC. 266

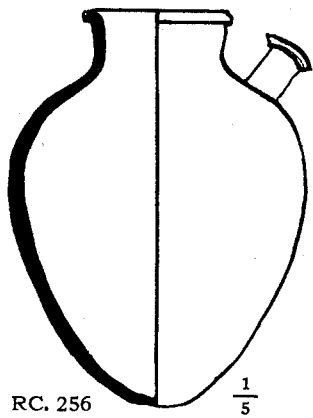

RC. 256

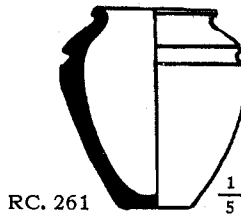

RC. 261

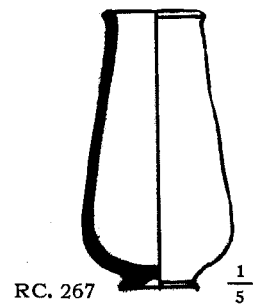

RC. 267

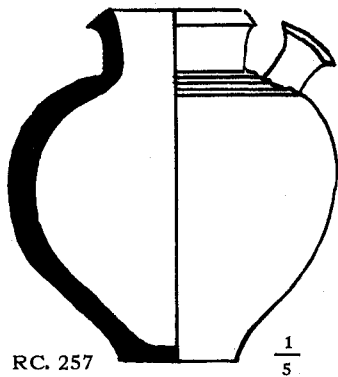

RC. 257

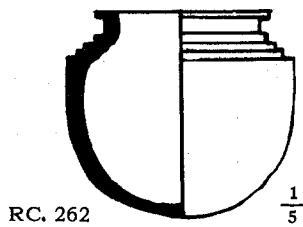

RC. 262

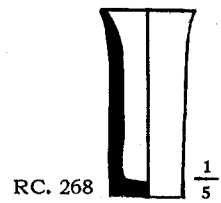

RC. 268



RC. 263

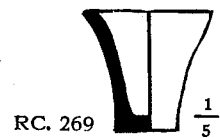

RC. 269

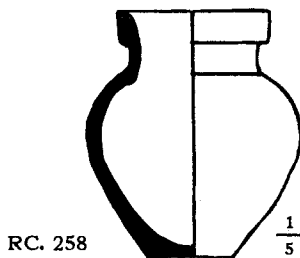

RC. 258

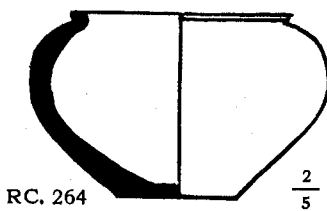

RC. 264



RC. 270

ADDITIONAL ROYAL CEMETERY AND SARGONID POTTERY TYPES

(Continued from Vol. II)

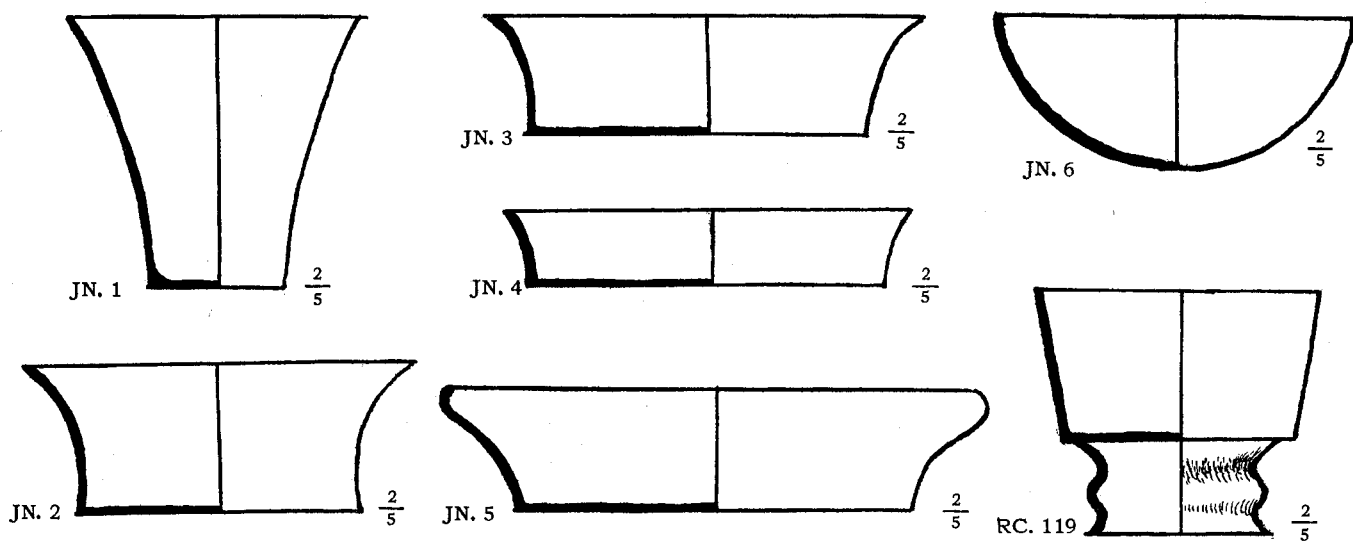

METAL VASES; JAMDAT NASR AND ROYAL CEMETERY

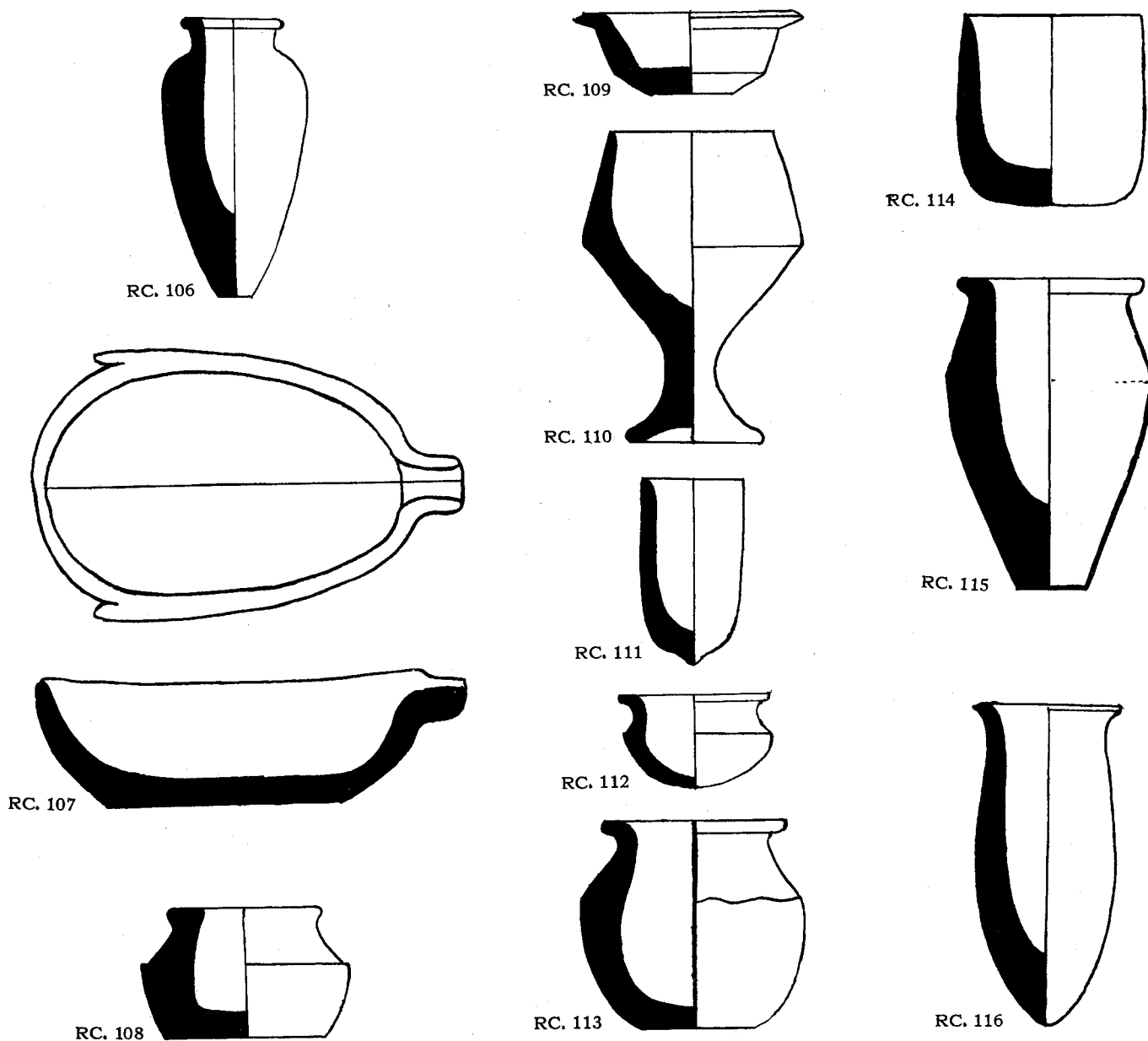

STONE VASE TYPES FROM THE ROYAL CEMETERY AND SARGONID GRAVES

(Continued from Vol. II)





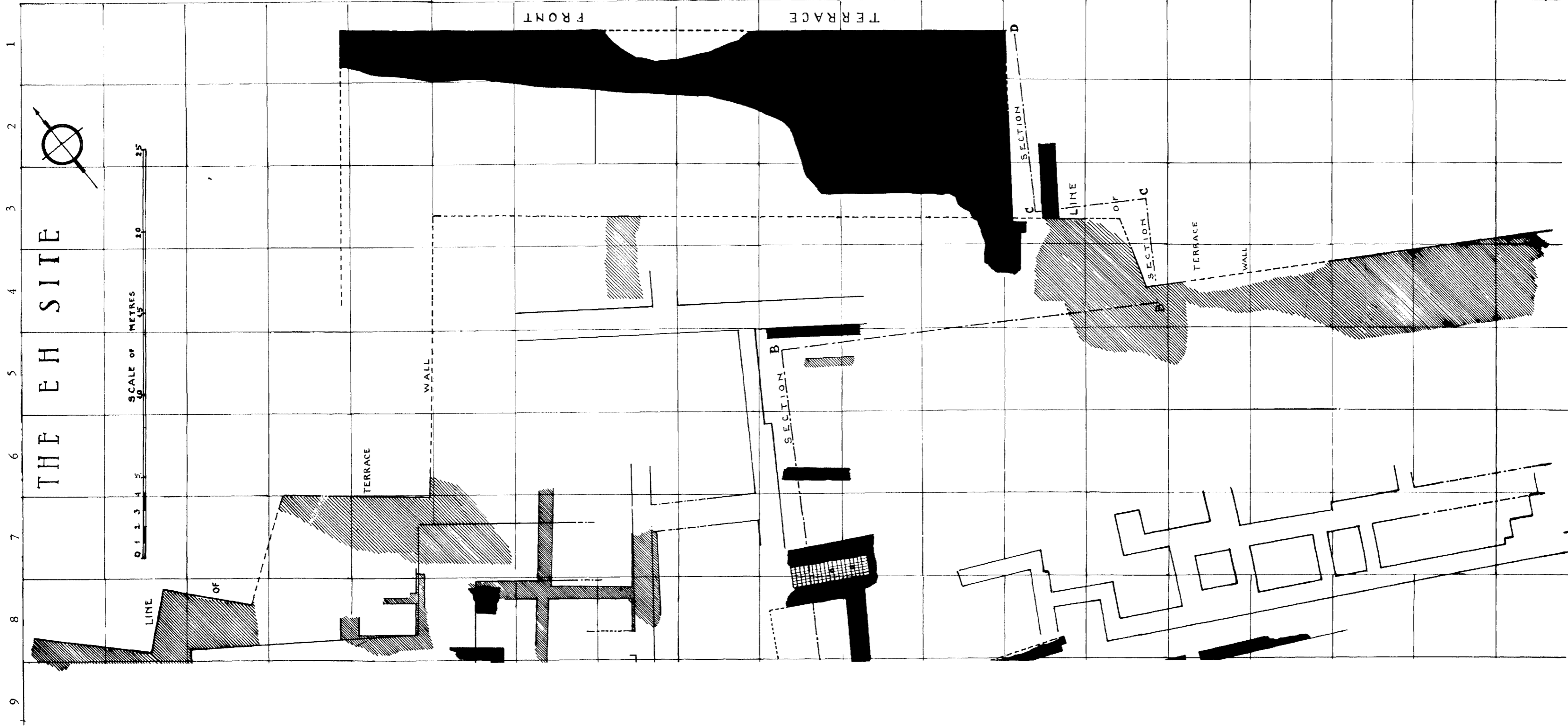

THE EH SITE

SCALE OF METRES  
0 1 2 3 4 5

LINE

OF

TERRACE

WALL

FRONT

SECTION B

SECTION C

LINE

SECTION C

TERRACE

WALL

PLAN OF EH SITE

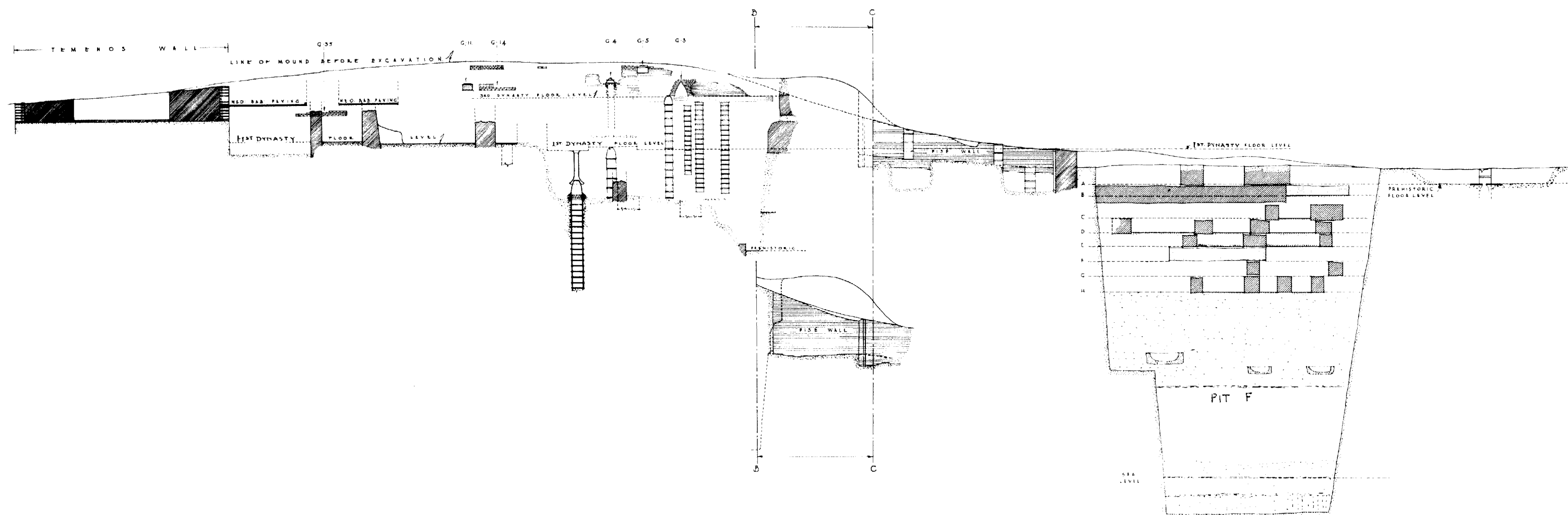

SITE EH: SECTION ON LINE A-B-C-D; LOOKING NORTHWEST SHOWING RELATION TO PIT F

Scale 0 1 2 3 4 5 6 7 8 9 10 metres

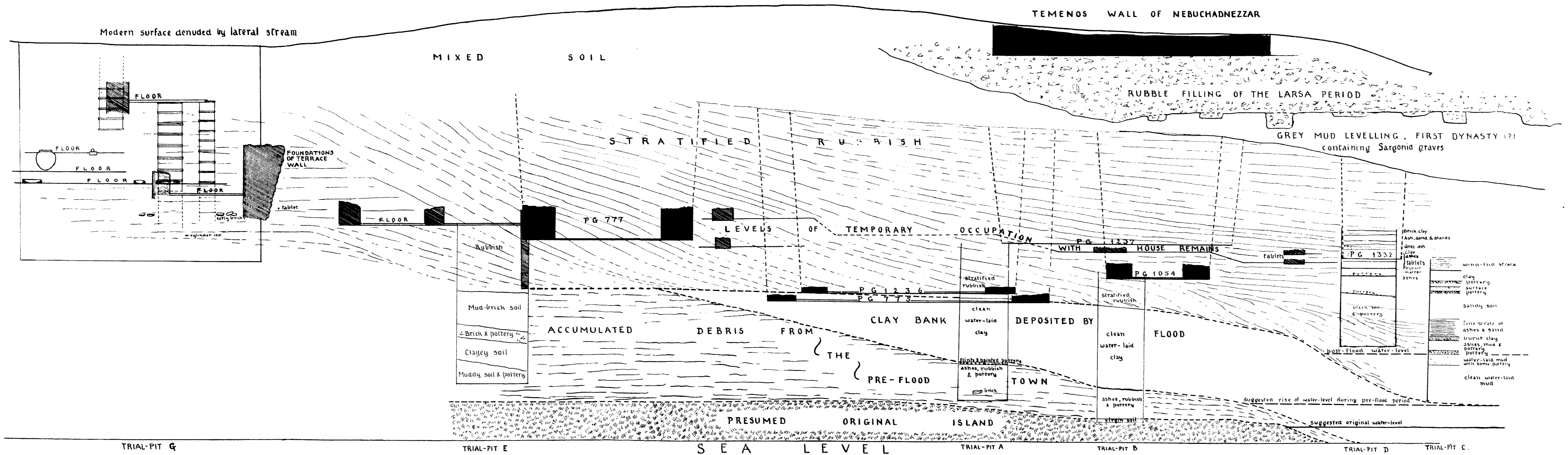

SECTION IN THE ROYAL CEMETERY AREA SHOWING THE POSITION OF PITS A-E AND G

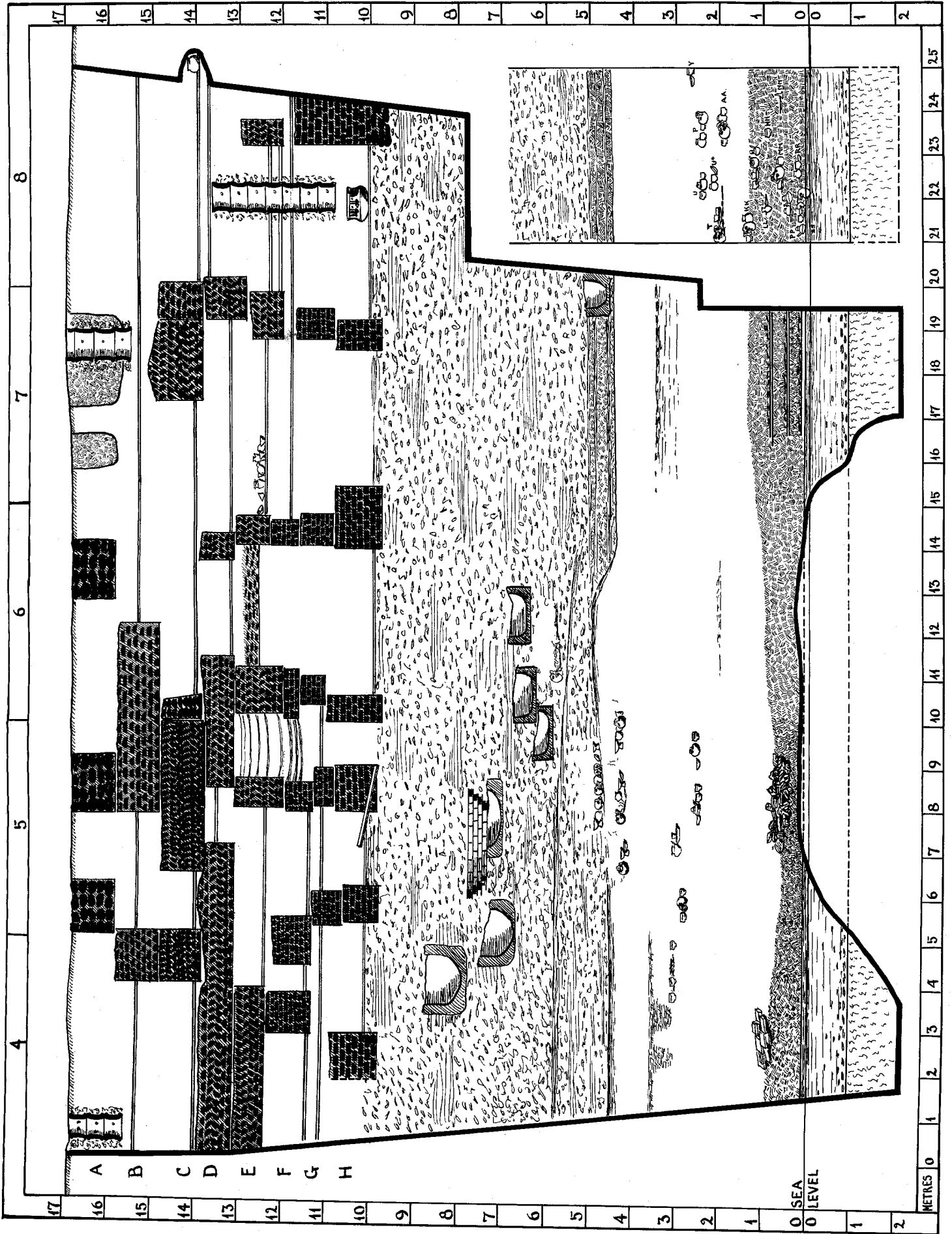

SECTION OF PIT F

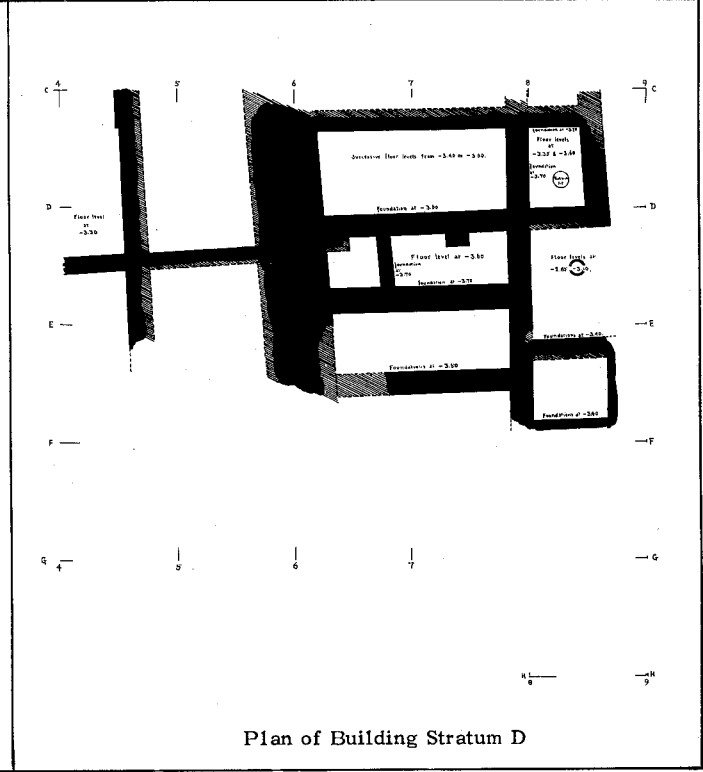
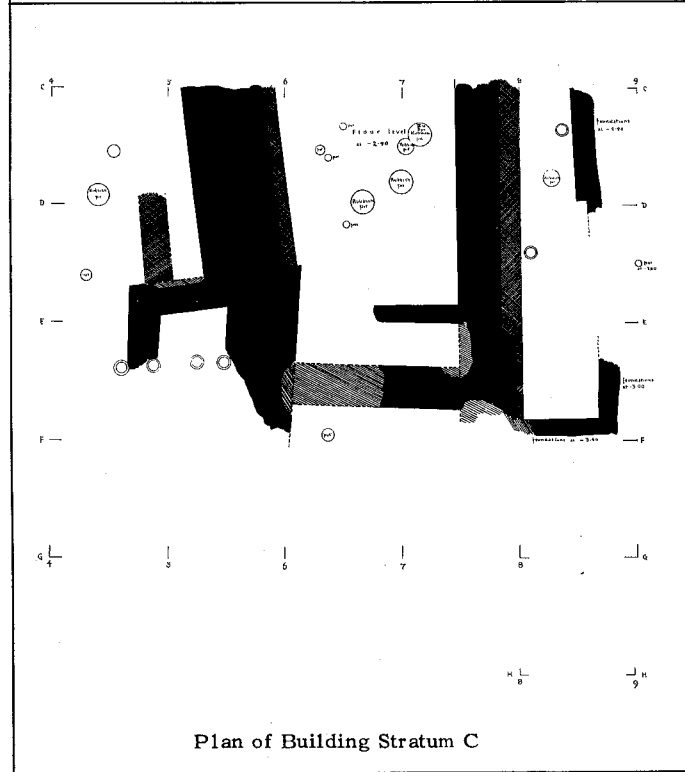
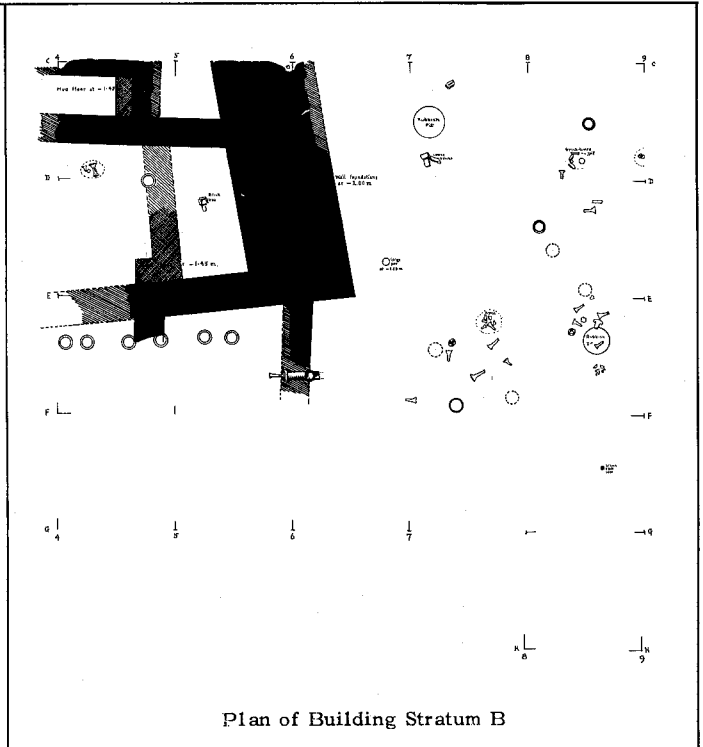
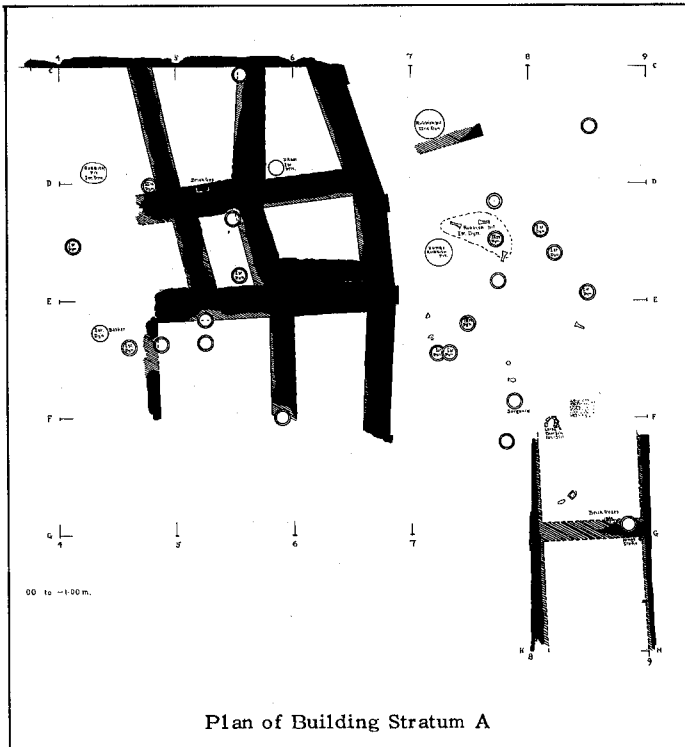

PIT F

The minus figures on these plans give depths from the datum line (existing ground surface) at which the work started. They are retained as giving a reader idea of the relative levels of walls and floors in each stratum. For heights above sea level *v.* the section, Plate 73.

A smaller scale has been adopted because the main interest of the plans lies in the comparison of the different Building Levels, for which purpose their closer grouping is desirable.

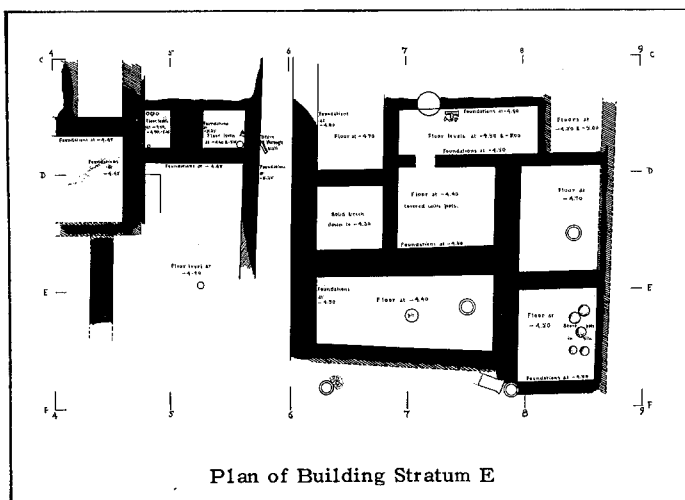

Plan of Building Stratum E

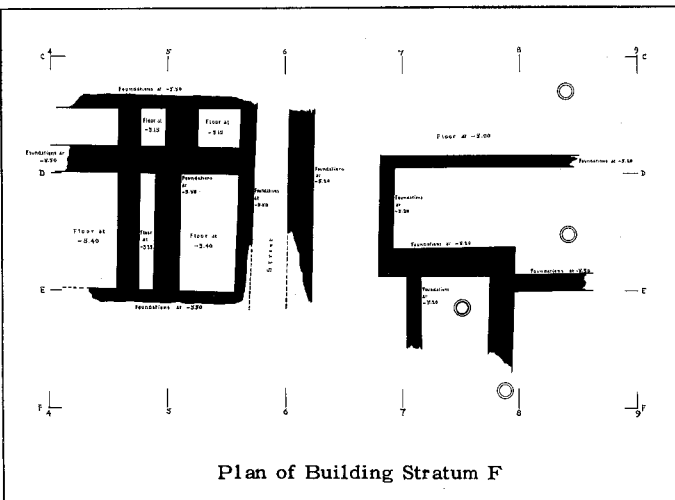

Plan of Building Stratum F

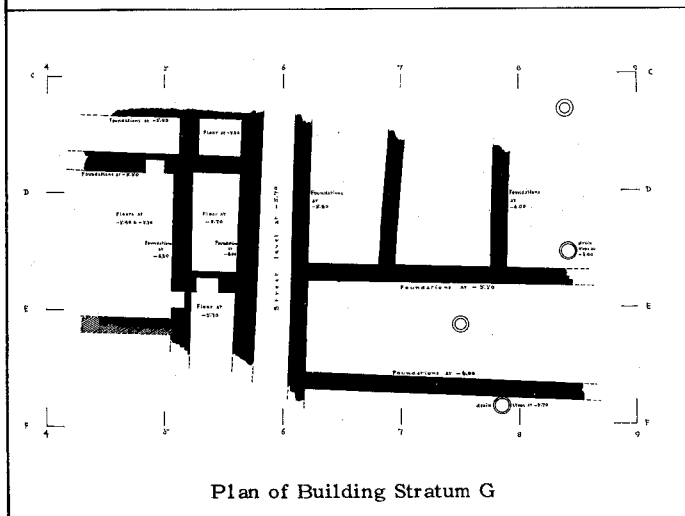

Plan of Building Stratum G

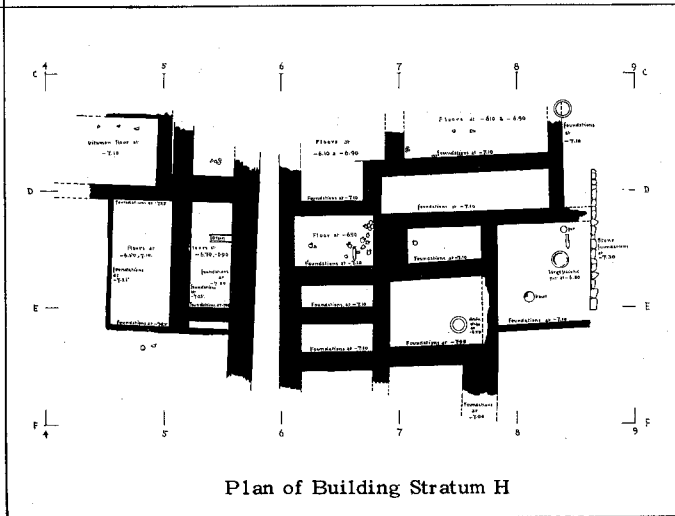

Plan of Building Stratum H

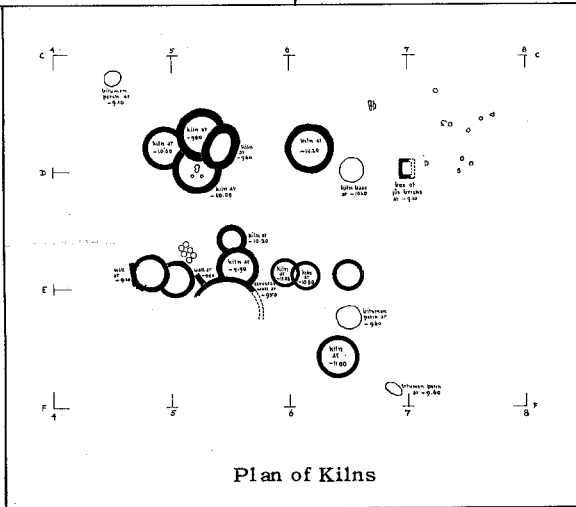

Plan of Kilns

PIT F

The minus figures on these plans give depths from the datum line (existing ground surface) at which the work started. They are retained as giving a readier idea of the relative levels of walls and floors in each stratum. For heights above sea level *v.* the section, Plate 73.

A smaller scale has been adopted because the main interest of the plans lies in the comparison of the different Building Levels, for which purpose their closer grouping is desirable.

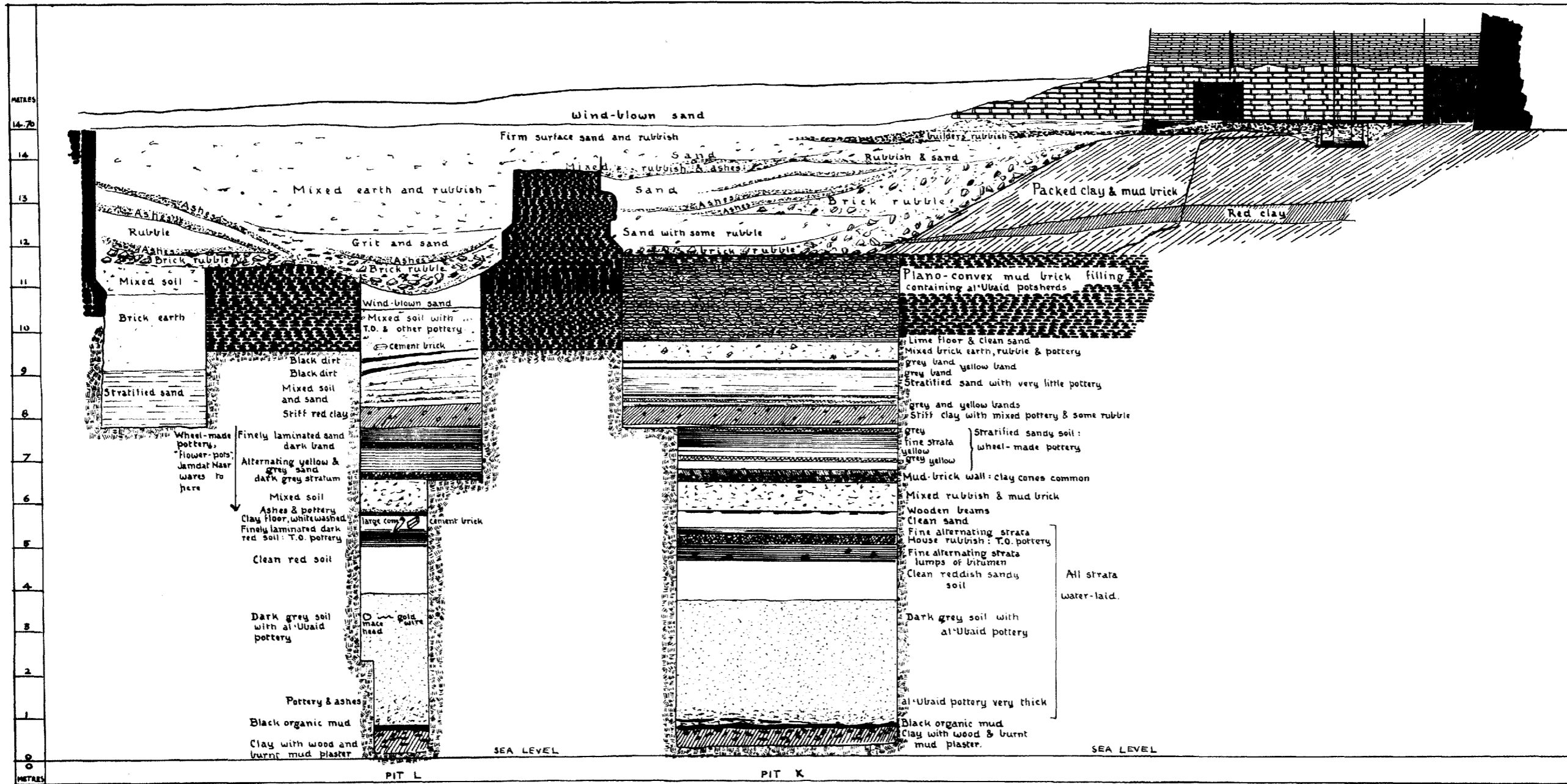

SECTION OF PITS K AND L

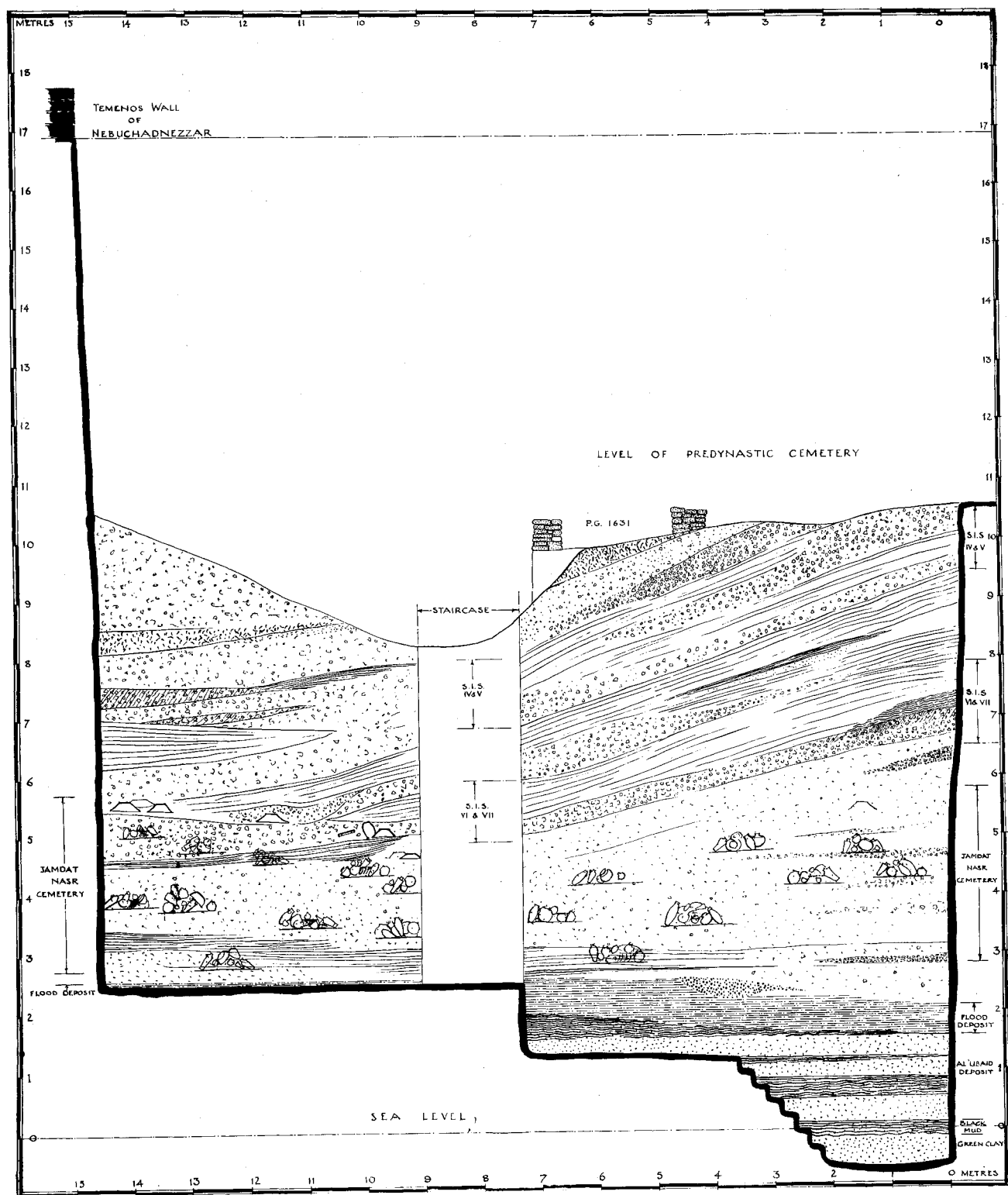

SECTION OF PIT W



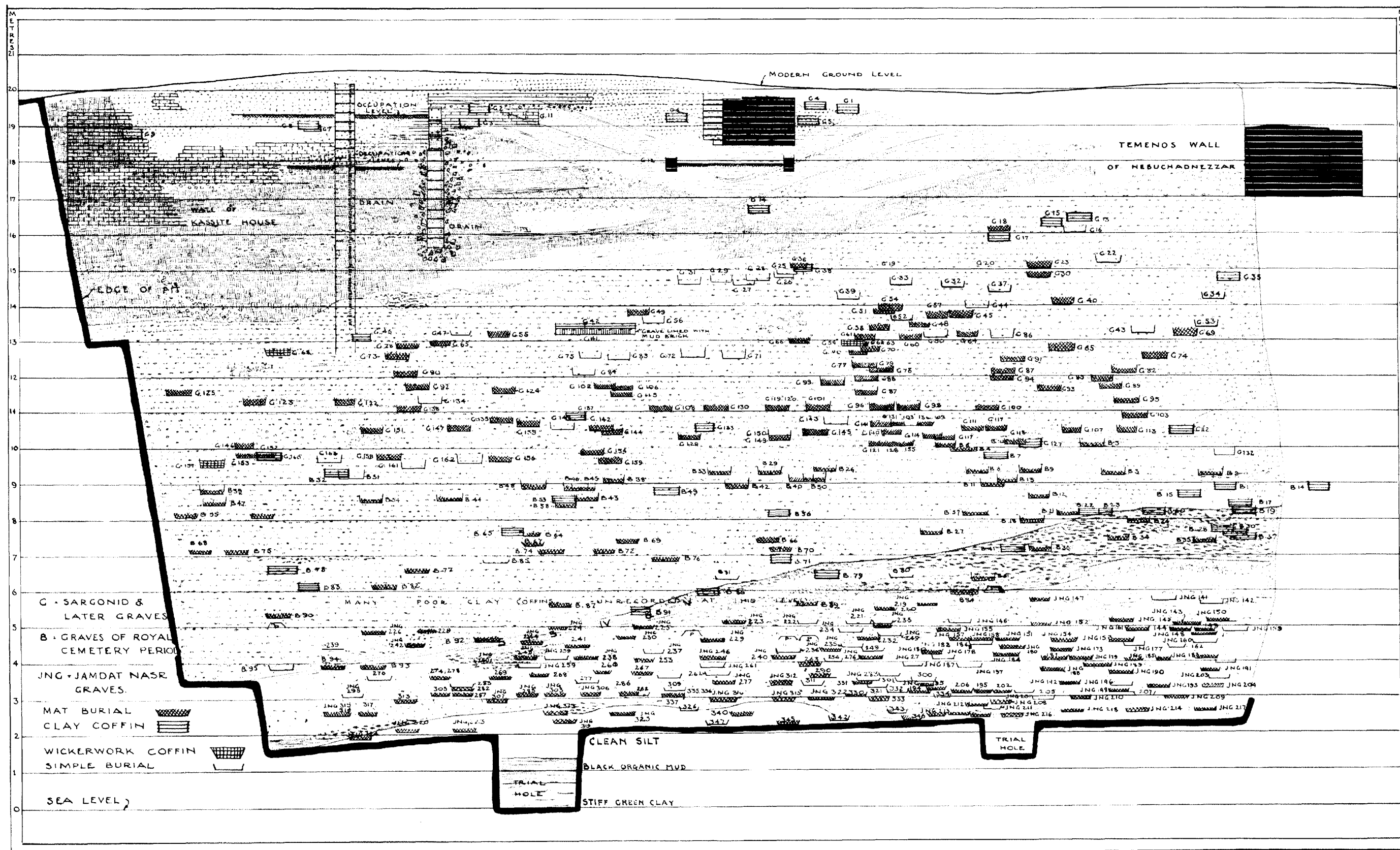

SECTION OF PIT X

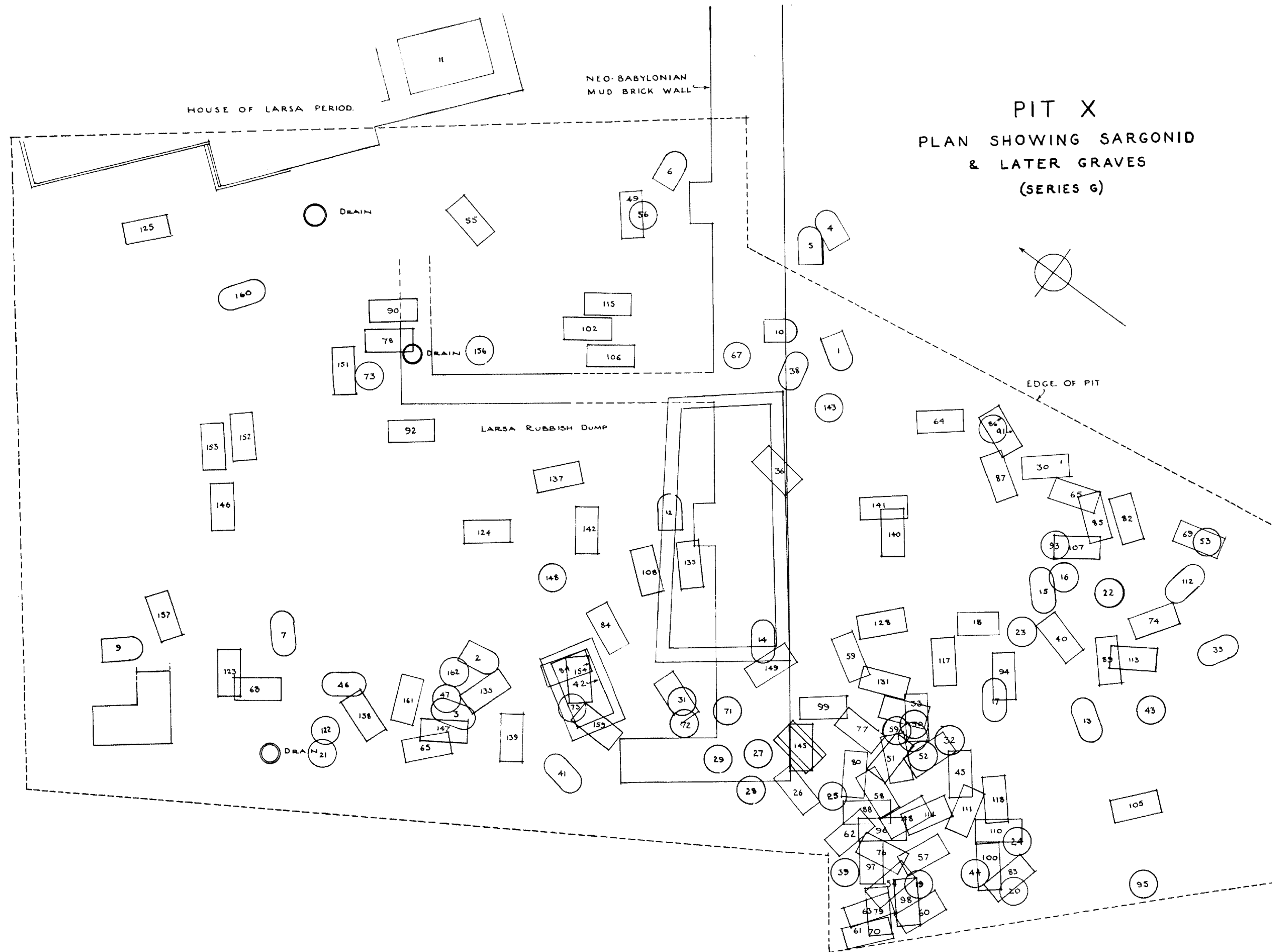

PIT X, PLAN SHOWING SARGONID AND LATER GRAVES

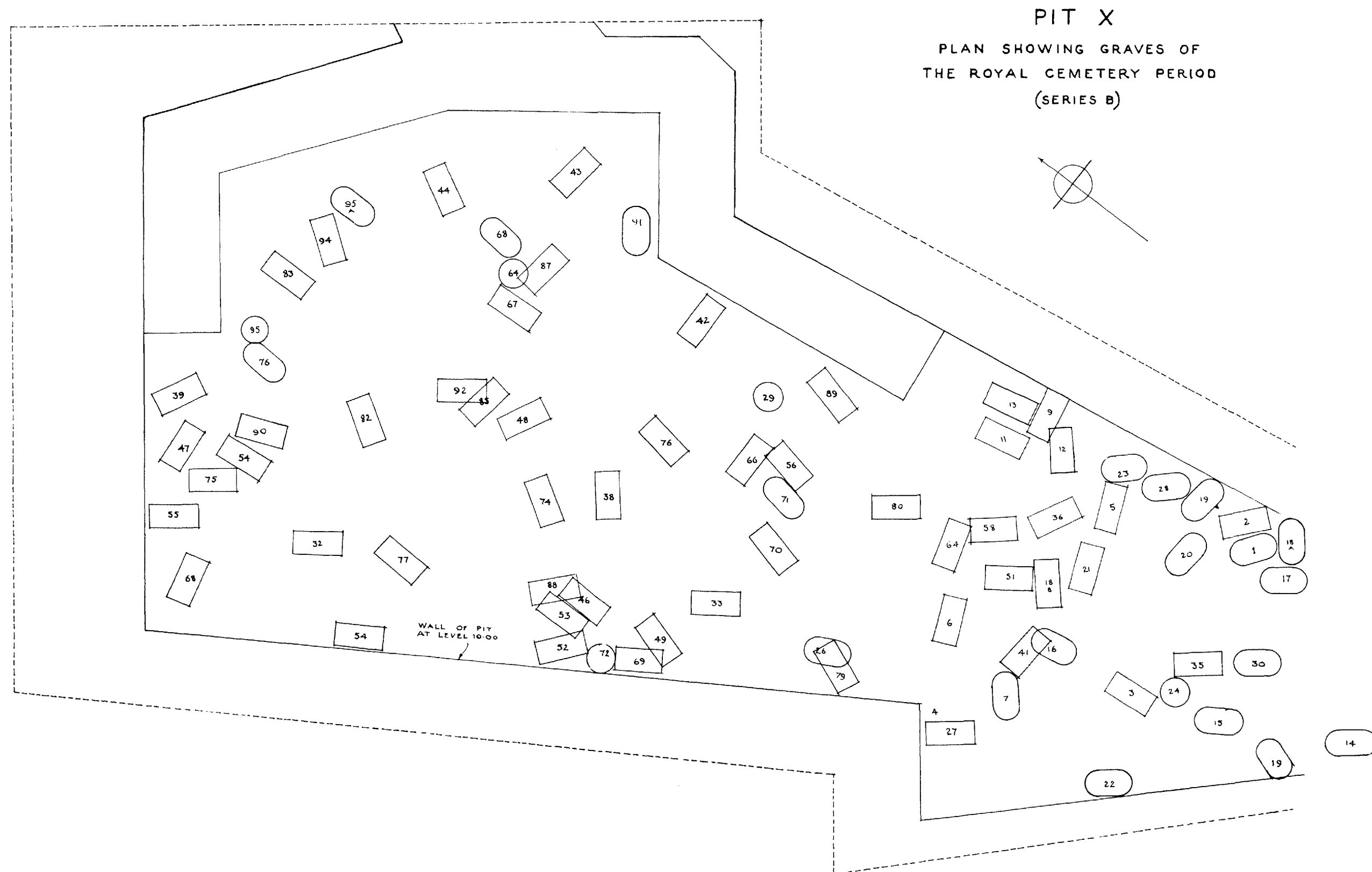

PIT X, PLAN SHOWING GRAVES OF THE ROYAL CEMETERY PERIOD

PIT X  
PLAN SHOWING JAMDAT NASR GRAVES  
(SERIES JNG)

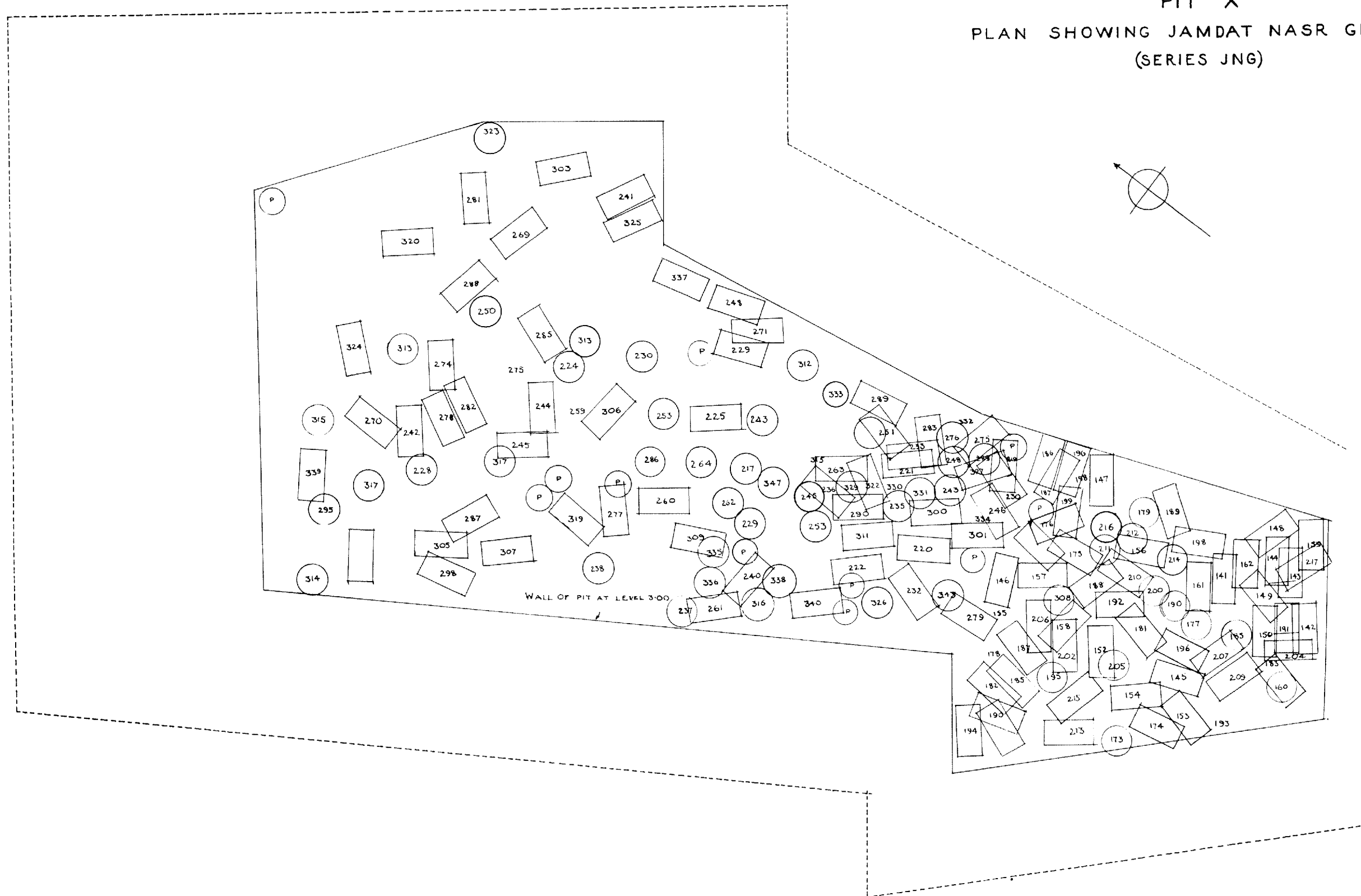

PIT X, PLAN SHOWING JAMDAT NASR GRAVES

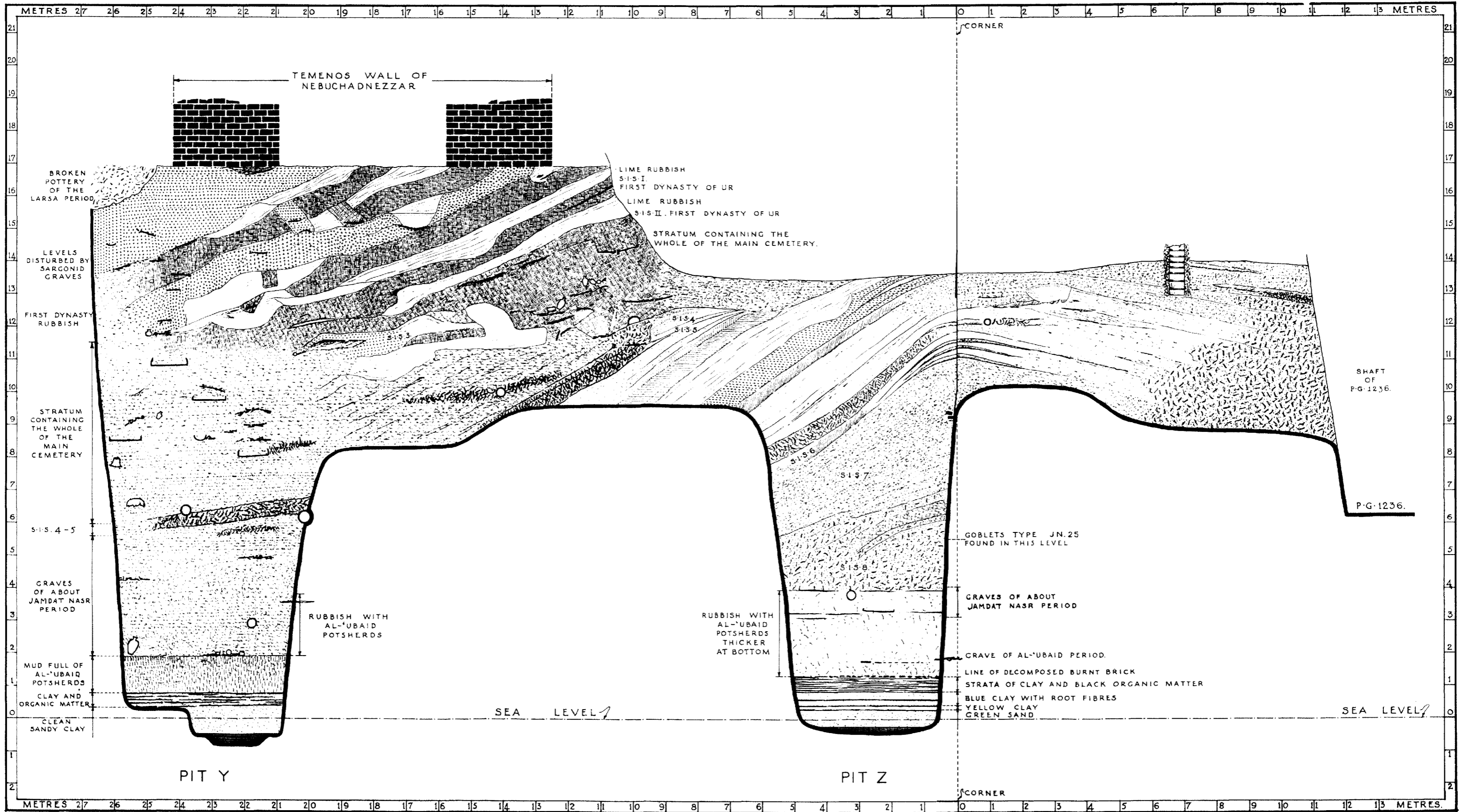

PITS Y AND Z

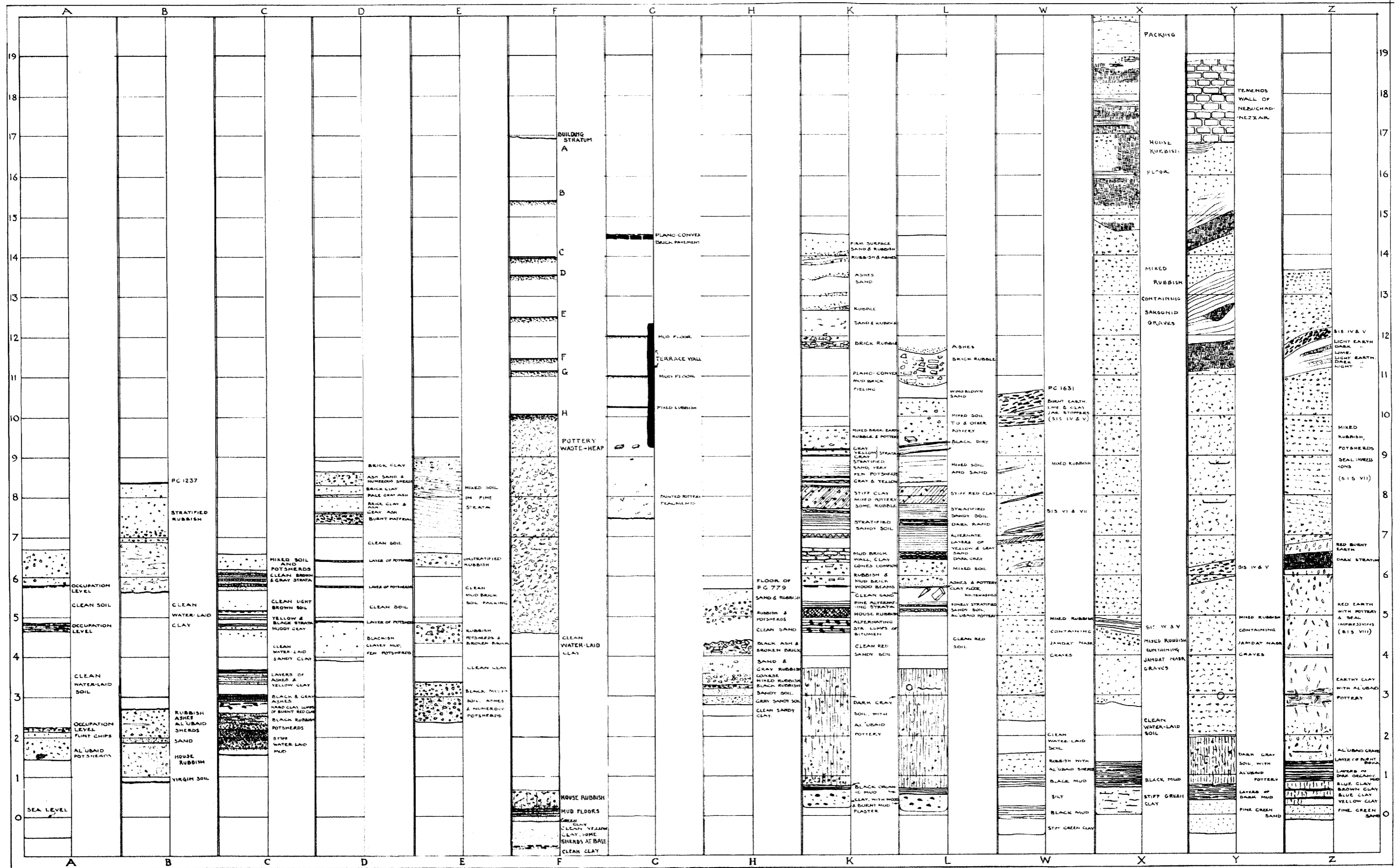

COMPARATIVE SECTIONS OF ALL THE PITS